

TECHNICAL MANUAL

DIRECT SUPPORT AND GENERAL SUPPORT MAINTENANCE MANUAL

FOR
CARRIER, PERSONNEL, FULL TRACKED, ARMORED M113A3
2350-01-219-7577 (EIC AEY)

CARRIER, COMMAND POST, LIGHT TRACKED M577A3
2350-01-369-6085 (EIC AE7)

CARRIER, SMOKE GENERATOR, FULL TRACKED M1059A3
2350-01-369-6083 (EIC AFA)

CARRIER, MORTAR, 120-MM M121, SELF-PROPELLED M1064A3
2350-01-369-6082 (EIC AE8)

CARRIER, STANDARDIZED INTEGRATED COMMAND POST SYSTEM
(SICPS) M1068A3
2350-01-369-6086 (EIC AFC)

CARRIER, MECHANIZED SMOKE OBSCURANT M58
2350-01-418-6654 (EIC 5CG)

SUPERSEDURE NOTICE — This manual supersedes TM 9-2350-277-34 dated 25 July 1994, including all changes.

DISTRIBUTION STATEMENT A — Approved for public release; distribution is unlimited.

HEADQUARTERS, DEPARTMENT OF THE ARMY

January 2001

WARNING SUMMARY

WARNING SUMMARY

This list summarizes critical WARNINGS in this manual. They are repeated here to let you know how important they are. Study these WARNINGS carefully; they can save your life and the lives of personnel you work with.

WARNING

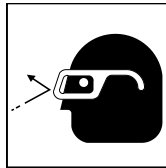

Compressed air used for cleaning purposes will not exceed 30 psi. Use only with effective chip guarding and personal protective equipment (goggles/shield, gloves, etc).

WARNING

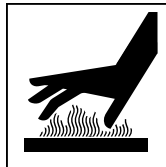

Do not handle hot or cold parts without protective gloves. Personnel can be injured.

WARNING

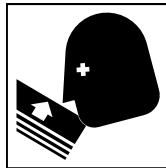

Power plant door may spring open. Soldiers can be injured. When opening, stay out of door path.

WARNING

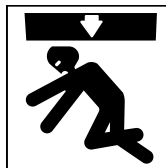

Hanging loads could kill or injure you. Keep away from hanging loads and overhead equipment.

WARNING SUMMARY (cont)

WARNING

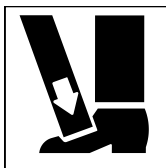

Failure to properly secure the engine and transmission can cause injury to personnel or damage to equipment.

WARNING

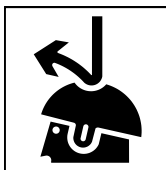

Parts could fall and injure you. Use helper or lifting device to move heavy parts.

WARNING



Fire resistant hydraulic (FRH) fluid may contain Tricresyl Phosphate which, if taken internally, can produce paralysis. Hydraulic fluid may be absorbed through the skin. Wear long sleeves, gloves, goggles, and face shield. If FRH gets in eyes, wash them immediately and get medical aid immediately. If FRH gets on skin, thoroughly wash with soap and water. Wash hands thoroughly prior to eating or smoking.

WARNING SUMMARY (cont)

WARNING

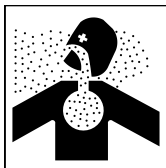

Chemical agent resistant coating (CARC) paint contains isocyanate (HDI) which is highly irritating to skin and respiratory system. High concentrations of HDI can produce symptoms of itching and reddening of skin, a burning sensation in throat and nose, and watering of the eyes. In extreme concentrations, HDI can cause cough, shortness of breath, pain during respiration, increased sputum production, and chest tightness. The following precautions must be taken whenever using CARC paint:

ALWAYS use air line respirators when using CARC paint unless air sampling shows exposure to be below standards. Use chemical cartridge respirator if air sampling is below standards.

DO NOT let skin or eyes come in contact with CARC paint. Always wear protective equipment (gloves, ventilation mask, safety goggles, etc.).

DO NOT use CARC paint without adequate ventilation.

NEVER weld or cut CARC-coated materials.

DO NOT grind or sand painted equipment without high-efficiency air purifying respirators in use.

BE AWARE of CARC paint exposure symptoms; symptoms can occur a few days after initial exposure. Seek medical help immediately if symptoms are detected.

WARNING



Mixing of CARC paint must be done in a well-ventilated mixing room or spraying area away from open flame with personnel wearing eye protection. Paint is flammable and can cause injury or death to personnel.

WARNING



Protective equipment (gloves, goggles, ventilation mask) must be worn when using CARC paint. **DO NOT** leave any skin exposed. Contact with CARC paint can cause skin burns.

WARNING SUMMARY (cont)

WARNING

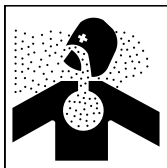

High efficiency air purifying respirators should be used when grinding or sanding CARC-coated equipment. Failure to do so may result in injury or death to personnel.

WARNING



Unsafe use of chemical products can injure you. Read and follow warnings and instructions on labels of all chemical products. Follow all general shop safety procedures. See supervisor for further instructions on safety.

WARNING



Lye or caustic substances will damage metal surfaces. Do not use lye or caustic mixtures to clean metal surfaces.

WARNING

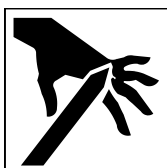

Unsafe use of tools and equipment can injure you. Read and follow warnings and instructions on labels of all equipment. Follow all general shop safety procedures. See supervisor for further instructions on safety.

FIRST AID

For first aid information, see FM 21-11.

CHANGE
NO. 3

HEADQUARTERS DEPARTMENT OF THE ARMY
WASHINGTON, D.C., 27 April 2004

TECHNICAL MANUAL

DIRECT SUPPORT AND GENERAL SUPPORT MAINTENANCE MANUAL

FOR

CARRIER, PERSONNEL, FULL TRACKED, ARMORED M113A3
2350-01-219-7577 (EIC AEY)

CARRIER, COMMAND POST, LIGHT TRACKED M577A3
2350-01-369-6085 (EIC AE7)

CARRIER, SMOKE GENERATOR, FULL TRACKED M1059A3
2350-01-369-6083 (EIC AFA)

CARRIER, MORTAR, 120-MM M121, SELF-PROPELLED M1064A3
2350-01-369-6082 (EIC AE8)

CARRIER, STANDARDIZED INTEGRATED COMMAND POST SYSTEM (SICPS) M1068A3
2350-01-369-6086 (EIC AFC)

CARRIER, MECHANIZED SMOKE OBSCURANT M58
2350-01-418-6654 (EIC 5CG)

DISTRIBUTION STATEMENT A – Approved for public release; distribution is unlimited.

TM 9-2350-277-34, 2 January 2001 is updated as follows:

1. File this change sheet in front of the publication for reference purposes.
2. New or updated text is indicated by a vertical bar in the outer margin of the page.
3. Revised illustrations are indicated by a miniature pointing hand adjacent to the updated area.
4. Remove old pages/Work Packages and insert new pages/Work Packages as indicated below.

Remove Pages/Work Packages

A/B blank
iii – iv
Chapter 11 Index
WP 0044 00
WP 0045 00
WP 0046 00
WP 0072 00
WP 0073 00
WP 0086 00
WP 0113 00
WP 0114 00
WP 0119 00
Index 5 – Index 6
Index 13 – Index 15/16 blank

Insert Pages/Work Packages

A/B blank
iii – iv
Chapter 11 Index
WP 0044 00
None
None
WP 0072 00
WP 0073 00
WP 0086 00
WP 0113 00
WP 0114 00
WP 0119 00
Index 5 – Index 6
Index 13 – Index 14

By Order of the Secretary of the Army:

Official:



*Administrative Assistant to the
Secretary of the Army*

0404105

PETER J. SCHOOMAKER
*General, United States Army
Chief of Staff*

DISTRIBUTION:

To be distributed in accordance with the initial distribution number (IDN) 371206 requirements for TM 9-2350-277-34.

CHANGE
NO. 2

HEADQUARTERS
DEPARTMENT OF THE ARMY
WASHINGTON, D.C., 02 October 2003

TECHNICAL MANUAL

DIRECT SUPPORT AND GENERAL SUPPORT MAINTENANCE MANUAL

FOR

**CARRIER, PERSONNEL, FULL TRACKED, ARMORED M113A3
2350-01-219-7577 (EIC AEY)**

**CARRIER, COMMAND POST, LIGHT TRACKED M577A3
2350-01-369-6085 (EIC AE7)**

**CARRIER, SMOKE GENERATOR, FULL TRACKED M1059A3
2350-01-369-6083 (EIC AFA)**

**CARRIER, MORTAR, 120-MM M121, SELF-PROPELLED M1064A3
2350-01-369-6082 (EIC AE8)**

**CARRIER, STANDARDIZED INTEGRATED COMMAND POST SYSTEM (SICPS) M1068A3
2350-01-369-6086 (EIC AFC)**

**CARRIER, MECHANIZED SMOKE OBSCURANT M58
2350-01-418-6654 (EIC 5CG)**

DISTRIBUTION STATEMENT A – Approved for public release; distribution is unlimited.

TM 9-2350-277-34, 2 January 2001 is updated as follows:

1. File this change sheet in front of the publication for reference purposes.
2. New or updated text is indicated by a vertical bar in the outer margin of the page.
3. Revised illustrations are indicated by a miniature pointing hand adjacent to the updated area.
4. Remove old pages/Work Packages and insert new pages/Work Packages as indicated below.

Remove Pages/Work Packages

A/B
i-viii
WP 0001 00 – 0003 00
WP 0013 00
WP 0015 00
Chapter 6 WP Index
WP 0032 00
WP 0033 00
Chapter 11 WP Index
WP 0042 00
WP 0048 00
WP 0050 00 – 0051 00
WP 60 00
Chapter 12 WP Index
WP 0064 00
Chapter 16 WP Index
WP 0075 00
Chapter 17 WP Index
WP 0089 00
Chapter 22 WP Index
WP 0115 00
WP 0119 00 – 0120 00
WP 0122 00
Index
Cover

Insert Pages/Work Packages

A/B
i-viii
WP 0001 00 – 0003 00
WP 0013 00
WP 0015 00
Chapter 6 WP Index
None
WP 0033 00
Chapter 11 WP Index
WP 0042 00
WP 0048 00
WP 0050 00 – 0051 00
WP 60 00
Chapter 12 WP Index
None
Chapter 16 WP Index
WP 0075 00
Chapter 17 WP Index
None
Chapter 22 WP Index
WP 0115 00
WP 0119 00 – 0120 00
WP 0122 00
Index
Cover

By Order of the Secretary of the Army:

PETER J. SCHOOMAKER
*General, United States Army Official:
Chief of Staff*

Official:

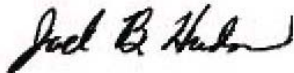

JOEL B. HUDSON
*Administrative Assistant to the
Secretary of the Army
0133211*

DISTRIBUTION:

To be distributed in accordance with the initial distribution number (IDN) 371206 requirements for TM 9-2350-277-34.

TECHNICAL MANUAL

DIRECT SUPPORT AND GENERAL SUPPORT MAINTENANCE MANUAL

FOR

**CARRIER, PERSONNEL, FULL TRACKED, ARMORED M113A3
2350-01-219-7577 (EIC AEY)**

**CARRIER, COMMAND POST, LIGHT TRACKED M577A3
2350-01-369-6085 (EIC AE7)**

**CARRIER, ANTI-TANK (TOW), FULL TRACKED, ARMORED M901A3
2350-01-369-7253 (EIC AFD)**

**CARRIER, FIRE SUPPORT PERSONNEL, FULL TRACKED, ARMORED M981A3
2350-01-369-6079 (EIC AFB)**

**CARRIER, SMOKE GENERATOR, FULL TRACKED M1059A3
2350-01-369-6083 (EIC AFA)**

**CARRIER, MORTAR, 120-MM M121, SELF-PROPELLED M1064A3
2350-01-369-6082 (EIC AE8)**

**CARRIER, STANDARDIZED INTEGRATED COMMAND POST SYSTEM (SICPS) M1068A3
2350-01-369-6086 (EIC AFC)**

**CARRIER, MECHANIZED SMOKE OBSCURANT M58
2350-01-418-6654 (EIC 5CG)**

DISTRIBUTION STATEMENT A – Approved for public release; distribution is unlimited.

TM 9-2350-277-34, 2 January 2001 is updated as follows:

1. File this change sheet in front of the publication for reference purposes.
2. New or updated text is indicated by a vertical bar in the outer margin of the page.
3. Revised illustrations are indicated by a miniature pointing hand adjacent to the updated area.
4. Remove old pages/Work Packages and insert new pages/Work Packages as indicated below.

Remove Pages/Work Packages

A/B
WP 0015 00
WP 0030 00
WP 0039 00
WP 0060 00
WP 0065 00
WP 0067 00
WP 0069 00
WP 0070 00
WP 0072 00
WP 0073 00
WP 0100 00
WP 0117 00

Insert Pages/Work Packages

A/B
WP 0015 00
WP 0030 00
WP 0039 00
WP 0060 00
WP 0065 00
WP 0067 00
WP 0069 00
WP 0070 00
WP 0072 00
WP 0073 00
WP 0100 00
WP 0117 00

By Order of the Secretary of the Army:

Official:



JOEL B. HUDSON

*Administrative Assistant to the
Secretary of the Army*
0133211

PETER J. SCHOOMAKER

*General, United States Army
Chief of Staff*

DISTRIBUTION:

To be distributed in accordance with the initial distribution number (IDN) 371206 requirements for TM 9-2350-277-34.

INSERT LATEST UPDATED PAGES/WORK PACKAGES. DESTROY SUPERSEDED DATA.

LIST OF EFFECTIVE PAGES/WORK PACKAGES

Note: Updates to all portions of this TM are indicated by a vertical bar in the outer margin of the page.

Dates of issue for original and updated pages/work packages are:

- Original 0 (2 January 2001)
- Change 1 (5 September 2003)
- Change 2 (2 October 2003)
- Change 3 (27 April 2004)

TOTAL NUMBER OF PAGES FOR FRONT AND REAR MATTER IS 54 AND TOTAL NUMBER OF WORK PACKAGES IS 122 CONSISTING OF THE FOLLOWING:

Page/WP No.	*Change No.	Page/WP No.	*Change No.	Page/WP No.	*Change No.
Cover	2	WP 0040 00 – 0041 00	0	WP 0105 00 – 0106 00	2
a-d	0	WP 0042 00	2	WP 0107 00 – 0108 00	0
A/B blank	3	WP 0043 00	0	Chapter 19 Index	0
i	2	WP 0044 00	3	WP 0109 00 – 0110 00	0
ii	0	WP 0045 00 – 0046 00 (Deleted)	3	Chapter 20 Index	0
iii	3	WP 0047 00	0	WP 0111 00 – 0112 00	0
iv – vii	2	WP 0048 00	2	Chapter 21 Index	0
viii – x	0	WP 0049 00	0	WP 0113 00 – 0114 00	3
Chapter 1 Index	0	WP 0050 00 – 0051 00	2	Chapter 22 Index	2
WP 0001 00 – 0003 00	2	WP 0052 00 – 0059 00	0	WP 0115 00	2
WP 0004 00	0	WP 0060 00	2	WP 0116 00	0
Chapter 2 Index	0	WP 0061 00	0	WP 0117 00	1
WP 0005 00 – 0012 00	0	Chapter 12 Index	2	WP 0118 00	0
Chapter 3 Index	0	WP 0062 00 – 0063 00	0	Chapter 23 Index	0
WP 0013 00	2	WP 0064 00 (Deleted)	2	WP 0119 00	3
WP 0014 00	0	Chapter 13 Index	0	WP 0120 00	2
WP 0015 00	2	WP 0065 00	1	WP 0121 00	0
WP 0016 00	0	Chapter 14 Index	0	WP 0122 00	2
Chapter 4 Index	0	WP 0066 00	0	Index 1 – Index 4	2
WP 0017 – 0018 00	0	WP 0067 00	1	Index 5 – Index 6	3
Chapter 5 Index	0	WP 0068 00	0	Index 7 – Index 12	2
WP 0019 00 – 0022 00	0	WP 0069 00	1	Index 13 – Index 14	3
Chapter 6 Index	2	WP 0070 00	1	Index 15/16 blank	2
WP 0023 00 – 0029 00	0	Chapter 15 Index	0	DA 2028 Sample/Reverse	0
WP 0030 00	1	WP 0071 00	0	DA 2028/Reverse (3)	0
WP 0031 00	0	Chapter 16 Index	2	Authentication	0
WP 0032 00 (Deleted)	2	WP 0072 00 – 0073 00	3	Metric Chart	0
WP 0033 00	2	WP 0074 00	0	Back Cover	0
WP 0034 00	0	WP 0075 00	2		
Chapter 7 Index	0	WP 0076 00 – 0085 00	0		
WP 0035 00	0	WP 0086 00	3		
Chapter 8 Index	0	WP 0087 00 – 0088 00	0		
WP 0036 00 – 0037 00	0	Chapter 17 Index (Deleted)	2		
Chapter 9 Index	0	WP 0089 00 (Deleted)	2		
WP 0038 00	0	Chapter 18 Index	0		
Chapter 10 Index	0	WP 0090 00 – 0099 00	0		
WP 0039 00	1	WP 0100 00	1		
Chapter 11 Index	3	WP 0101 00 – 0104 00	0		

*Zero in this column indicates an original page

Change 3

HEADQUARTERS
DEPARTMENT OF THE ARMY
WASHINGTON, D.C., 02 January 2001

TECHNICAL MANUAL

DIRECT SUPPORT AND GENERAL SUPPORT MAINTENANCE MANUAL

CARRIER, PERSONNEL, FULL TRACKED, ARMORED M113A3
NSN 2350-01-219-7577
(EIC AEY)

CARRIER, COMMAND POST, LIGHT TRACKED M577A3
NSN 2350-01-369-6085
(EIC AE7)

CARRIER, SMOKE GENERATOR, FULL TRACKED M1059A3
NSN 2350-01-369-6083
(EIC AFA)

CARRIER, MORTAR, 120-MM M121, SELF-PROPELLED M1064A3
NSN 2350-01-369-6082
(EIC AE8)

CARRIER, STANDARDIZED INTEGRATED COMMAND POST SYSTEM (SICPS) M1068A3
NSN 2350-01-369-6086
(EIC AFC)

CARRIER, MECHANIZED SMOKE OBSCURANT M58
NSN 2350-01-418-6654
(EIC 5CG)

REPORTING ERRORS AND RECOMMENDING IMPROVEMENTS

You can help improve this publication. If you find any mistakes or if you know of a way to improve the procedures, please let us know. Submit your DA Form 2028-2 (Recommended Changes to Equipment Technical Publications), through the Internet, on the Army Electronic Product Support (AEPS) website. The internet address is <http://aeprs.ria.army.mil>. If you need a password, scroll down and click on "ACCESS REQUEST FORM". The DA 2028 is located in the ONLINE FORMS PROCESSING section of the AEPS. Fill out the form and click on SUBMIT. Using this form on the AEPS will enable us to respond quicker to your comments and better manage the DA Form 2028 program. You may also mail, fax, or E-mail your letter, DA Form 2028 or DA Form 2028-2 direct to: Technical Publication Information Office, TACOM-RI, 1 Rock Island Arsenal, Rock Island, IL 61299-7630. The email address is TACOM-TECH-PUBS@ria.army.mil. The fax number is DSN 793-0726 or Commercial (309)782-0726.

SUPERSEDURE NOTICE — This manual supersedes TM 9-2350-277-34 dated 24 July 1994, including all changes.

DISTRIBUTION STATEMENT A — Approved for public release; distribution is unlimited.

TABLE OF CONTENTS

WP Sequence No.

WARNING SUMMARY

HOW TO USE THIS MANUAL

CHAPTER 1 — DIRECT SUPPORT INTRODUCTORY INFORMATION WITH THEORY OF OPERATION

GENERAL INFORMATION.....	0001 00
EQUIPMENT DESCRIPTION.....	0002 00
THEORY OF OPERATION.....	0003 00
REPAIR PARTS, SPECIAL TOOLS, TMDE, AND SUPPORT EQUIPMENT.....	0004 00

CHAPTER 2 — DIRECT SUPPORT TROUBLESHOOTING PROCEDURES

INTRODUCTION HOW TO USE TROUBLESHOOTING.....	0005 00
MALFUNCTION/SYMPTOM INDEX WP.....	0006 00
VEHICLE BATTERIES DISCHARGE WITH EXTERNAL AC POWER APPLIED (M1068A3 ONLY).....	0007 00
VEHICLE WILL NOT ACCEPT EXTERNAL AC POWER (M1068A3 ONLY).....	0008 00
NO DC OUTPUT FROM DC POWER SUPPLY (M1068A3 ONLY).....	0009 00
PATCH PANEL BOX A10 INOPERATIVE (M1068A3 ONLY).....	0010 00
EXTERNAL COMMUNICATION BOX A11 INOPERATIVE (M1068A3 ONLY).....	0011 00
PATCH PANEL BOX A10.....	0012 00

CHAPTER 3 — DIRECT SUPPORT MAINTENANCE INSTRUCTIONS FOR GENERAL MAINTENANCE INSTRUCTIONS FOR ENGINES

SERVICE UPON RECEIPT.....	0013 00
PREVENTIVE MAINTENANCE CHECKS AND SERVICES (PMCS), INCLUDING LUBRICATION INSTRUCTIONS.....	0014 00
REPLACE ENGINE.....	0015 00
REPLACE VARIABLE SPEED ADAPTER.....	0016 00

CHAPTER 4 — DIRECT SUPPORT MAINTENANCE INSTRUCTIONS FOR FUEL SYSTEM

REPAIR FUEL TANK (M577A3 AND M1068A3 ONLY).....	0017 00
REPAIR/REPLACE ACCELERATOR STOP SUPPORT ASSEMBLY.....	0018 00

CHAPTER 5 — DIRECT SUPPORT MAINTENANCE INSTRUCTIONS FOR COOLING SYSTEM

REPAIR RADIATOR.....	0019 00
REPAIR RADIATOR AUXILIARY TANK.....	0020 00
REPAIR VENTILATING FAN ASSEMBLY.....	0021 00
REPAIR FAN DRIVE SHAFT AND BEARING HOUSING.....	0022 00

CHAPTER 6 — DIRECT SUPPORT MAINTENANCE INSTRUCTIONS FOR ELECTRICAL SYSTEM

TABLE OF CONTENTS (cont)

WP Sequence No.

REPAIR GENERATOR.....	0023 00
REPLACE WARNING LIGHT PANEL MOUNTING BRACKET.....	0024 00
REPAIR BATTERY.....	0025 00
REPAIR MULTIPIN CONNECTORS.....	0026 00
REPAIR ENGINE WIRING HARNESS.....	0027 00
REPAIR TRANSMISSION WIRING HARNESS.....	0028 00
REPAIR TRANSMISSION CONTROL WIRING HARNESS.....	0029 00
REPLACE FRONT MAIN WIRING HARNESS.....	0030 00
REPAIR FRONT MAIN WIRING HARNESS.....	0031 00
DELETED.....	0032 00
REPAIR SMOKE GRENADE LAUNCHER WIRING HARNESS (M113A3 AND M1059A3 ONLY).....	0033 00
REPAIR STEERING LOCK SWITCH WIRING HARNESS.....	0034 00
 CHAPTER 7 — DIRECT SUPPORT MAINTENANCE INSTRUCTIONS FOR TRANSMISSION	
REPLACE TRANSMISSION.....	0035 00
 CHAPTER 8 — DIRECT SUPPORT MAINTENANCE INSTRUCTIONS FOR WHEELS AND TRACKS	
REPAIR TRACK IDLER ARM.....	0036 00
REPAIR TRACK TENSION ADJUSTER.....	0037 00
 CHAPTER 9 — DIRECT SUPPORT MAINTENANCE INSTRUCTIONS FOR STEERING	
REPAIR STEERING BRACKET AND SHAFT HOUSING BEARINGS.....	0038 00
 CHAPTER 10 — DIRECT SUPPORT MAINTENANCE INSTRUCTIONS FOR SHOCK ADSORBERS	
REPAIR SHOCK ABSORBER.....	0039 00
 CHAPTER 11 — DIRECT SUPPORT MAINTENANCE INSTRUCTIONS FOR HULL	
REPLACE SERRATED LOCK RING SCREW INSERTS.....	0040 00
REPLACE SERRATED LOCK RING SCREW INSERT AND PACKING.....	0041 00
REPLACE KEY LOCKED SCREW INSERTS.....	0042 00
REPLACE PRESSNUT.....	0043 00
REPLACE LEFT OR RIGHT SPLASH GUARD.....	0044 00
DELETED..... □	0045 00
DELETED..... □	0046 00
REPAIR POWER PLANT DOOR HINGE.....	0047 00
REPAIR CARGO HATCH HINGE (M113A3 AND M1059A3).....	0048 00
REPAIR HOPPER HATCH HINGE (M58 ONLY).....	0049 00
REPLACE COMMANDER’S CUPOLA (M113A3, M1059A3, M1064A3, AND M58 ONLY).....	0050 00
REPAIR COMMANDER’S CUPOLA (M113A3, M1059A3, M1064A3, AND M58 ONLY).....	0051 00

TABLE OF CONTENTS (cont)

WP Sequence No.

REPAIR COMMANDER’S CUPOLA BEARING (M113A3, M1059A3, M1064A3, AND M58 ONLY).....	0052 00
REPAIR COMMANDER’S CUPOLA COVER HINGES (M113A3, M1059A3, M1064A3, AND M58 ONLY).....	0053 00
REPAIR COMMANDER’S CUPOLA HINGES (M113A3, M1059A3, M1064A3, AND M58 ONLY).....	0054 00
REPAIR COMMANDER’S HATCH COVER HINGES (M577A3 AND M1068A3 ONLY).....	0055 00
REPAIR COMMANDER’S HATCH COVER HULL HINGES (M577A3 AND M1068A3 ONLY).....	0056 00
REPLACE RAMP ACCESS DOOR AND HINGES (M113A3 ONLY).....	0057 00
REPLACE RAMP ACCESS DOOR HINGE BEARINGS (M113A3 ONLY).....	0058 00
REPAIR RAMP ACCESS DOOR (ALL EXCEPT M113A3).....	0059 00
REPAIR DRIVER’S HATCH COVER HINGES.....	0060 00
REPAIR DRIVER’S HATCH COVER HULL HINGES.....	0061 00
 CHAPTER 12 — DIRECT SUPPORT MAINTENANCE INSTRUCTIONS FOR HULL ACCESSORY ITEMS	
REPAIR TENT (M577A3 ONLY).....	0062 00
REPAIR TENT (M1068A3 ONLY).....	0063 00
DELETED.....	0064 00
 CHAPTER 13 — DIRECT SUPPORT MAINTENANCE INSTRUCTIONS FOR HYDRAULIC SYSTEM	
REPLACE RAMP HYDRAULIC CYLINDER ANCHOR (M1064A3 ONLY).....	0065 00
 CHAPTER 14 — DIRECT SUPPORT MAINTENANCE INSTRUCTIONS FOR TOOLS AND TEST EQUIPMENT	
TEST LOAD POWER PLANT SLING.....	0066 00
REPAIR POWER PLANT SLING.....	0067 00
ADJUST ENGINE AND TRANSMISSION STAND.....	0068 00
SERVICE ENGINE AND TRANSMISSION STAND.....	0069 00
REPAIR ENGINE AND TRANSMISSION STAND.....	0070 00
 CHAPTER 15 — DIRECT SUPPORT MAINTENANCE INSTRUCTIONS FOR AUXILIARY GENERATOR	
REPAIR AUXILIARY POWER UNIT COVER (M577A3 AND M1068A3 ONLY).....	0071 00
 CHAPTER 16 — DIRECT SUPPORT MAINTENANCE INSTRUCTIONS FOR MAINTENANCE OF SPECIAL PURPOSE KITS	
INSTALL PERSONNEL HEATER KIT (M113A3, M1059A3, AND M58 ONLY).....	0072 00
INSTALL PERSONNEL HEATER KIT (M1064A3 ONLY).....	0073 00
REPAIR PERSONNEL HEATER ASSEMBLY.....	0074 00
INSTALL ENGINE COOLANT HEATER KIT (M113A3 AND M1059A3).....	0075 00
ENGINE COOLANT HEATER DATA.....	0076 00

TABLE OF CONTENTS (cont)

WP Sequence No.

FINAL TEST -- COOLANT HEATER.....	0077 00
REPLACE FUEL CONTROL VALVE.....	0078 00
REPLACE RESTRICTION THERMOSTAT.....	0079 00
REPLACE OVERHEAT THERMOSTAT.....	0080 00
REPLACE FIXED RESISTOR.....	0081 00
REPLACE BURNER PACKING AND GASKET.....	0082 00
REPLACE DIODE AND MOTOR RESISTOR.....	0083 00
REPLACE BLOWER MOTOR.....	0084 00
INSTALL NON-SKID RAMP KIT (M1064A3 ONLY).....	0085 00
INSTALL CAPSTAN KIT (M1059A3 ONLY).....	0086 00
INSTALL ANCHOR KIT (M1059A3 ONLY).....	0087 00
INSTALL COMMANDER’S CUPOLA ARMOR SHIELDS (M113A3 AND M1064A3 ONLY).....	0088 00
 CHAPTER 17 □ DELETED	
DELETED.....	0089 00
 CHAPTER 18 — DIRECT SUPPORT MAINTENANCE INSTRUCTIONS FOR ELECTRICAL EQUIPMENT (M1068A3 ONLY)	
REPLACE POWER CONTROL ENCLOSURE POWER SUPPLIES (M1068A3 ONLY).....	0090 00
REPAIR POWER CONTROL ENCLOSURE, LEFT PANEL (M1068A3 ONLY).....	0091 00
REPAIR POWER CONTROL ENCLOSURE, RIGHT PANEL (M1068A3 ONLY).....	0092 00
REPAIR POWER CONTROL ENCLOSURE, REAR PANEL (M1068A3 ONLY).....	0093 00
REPLACE/REPAIR INVERTER AND INVERTER HOUSING ASSEMBLY A2 (M1068A3 ONLY).....	0094 00
REPAIR POWER ENTRY BOX ASSEMBLY A4 (M1068A3 ONLY).....	0095 00
REPAIR TENT INTERFACE PANEL BOX ASSEMBLY A5 (M1068A3 ONLY).....	0096 00
REPAIR AC POWER EXTENSION BOXES A6 AND A7 (M1068A3 ONLY).....	0097 00
REPAIR ROADSIDE DC POWER EXTENSION BOX A9 (M1068A3 ONLY).....	0098 00
REPAIR SIGNAL PATCH PANEL BOX A10 (M1068A3 ONLY).....	0099 00
REPAIR EXTERNAL COMMUNICATION BOX A11 (M1068A3 ONLY).....	0100 00
REPAIR ROADSIDE AND CURBSIDE DATA PANEL ASSEMBLIES A12 AND A13 (M1068A3 ONLY).....	0101 00
REPAIR PHONE EXTENSION BOX A14 (M1068A3 ONLY).....	0102 00
REPAIR ROADSIDE AC POWER EXTENSION BOX A18 (M1068A3 ONLY).....	0103 00
REPAIR CURBSIDE AC POWER EXTENSION BOX A19 (M1068A3 ONLY).....	0104 00
REPLACE LAN A CABLE W101 AND/OR LAN B CABLE W102 (M1068A3 ONLY).....	0105 00
REPLACE RF 1, 2, 3, 4 CABLE ASSEMBLIES W111, W112, W113, AND W114 (M1068A3 ONLY).....	0106 00
REPLACE CABLE ASSEMBLY W115 (M1068A3 ONLY).....	0107 00
REPLACE CABLE ASSEMBLIES W117 AND W118 (M1068A3 ONLY).....	0108 00

TABLE OF CONTENTS (cont)

WP Sequence No.

CHAPTER 19 — DIRECT SUPPORT MAINTENANCE INSTRUCTIONS FOR PRECISION INSTRUMENTS AND SYSTEMS

REPAIR STE/ICE DISTRIBUTION BOX.....0109 00

REPAIR STE/ICE WIRING HARNESS.....0110 00

CHAPTER 20 — DIRECT SUPPORT MAINTENANCE INSTRUCTIONS FOR FIRE FIGHTING EQUIPMENT

SERVICE CHEMICAL FIRE EXTINGUISHER (M1059A3 ONLY).....0111 00

SERVICE FIRE EXTINGUISHER CYLINDER AND SAFETY DISC.....0112 00

CHAPTER 21 — DIRECT SUPPORT MAINTENANCE INSTRUCTIONS FOR SHIPPING CLOSURE AND FRAME

REMOVE SHIPPING CLOSURE AND FRAME (ALL EXCEPT M577A3 AND M1068A3).....0113 00

REMOVE SHIPPING CLOSURE AND FRAME (M577A3 AND M1068A3 ONLY).....0114 00

CHAPTER 22 — DIRECT SUPPORT MAINTENANCE INSTRUCTIONS FOR GENERAL SUPPORT MAINTENANCE

REPAIR FAN AND GENERATOR VARIABLE SPEED DRIVE (OLD CONFIGURATION).....0115 00

REPAIR/OVERHAUL FINAL DRIVE ASSEMBLY.....0116 00

REPLACE LOCKED-IN STUDS (M577A3 ONLY).....0117 00

REPLACE OVERSIZE SCREW INSERTS WITH LOCKRING.....0118 00

CHAPTER 23 — DIRECT SUPPORT SUPPORTING INFORMATION

REFERENCES.....0119 00

COMMON TOOLS AND SUPPLEMENTS AND SPECIAL TOOLS/FIXTURES LIST.....0120 00

FABRICATED TOOLS.....0121 00

EXPENDABLE/DURABLE SUPPLIES AND MATERIALS LIST.....0122 00

HOW TO USE THIS MANUAL

HOW TO USE THIS MANUAL

This manual tells you how to perform direct and general support maintenance for the M113A3, M577A3, M1059A3, M1064A3, M1068A3, and M58 Carriers.

Before starting a task or procedure, read HOW TO USE THIS MANUAL and CHAPTER 3, GENERAL MAINTENANCE PROCEDURES.

WHAT'S IN THE MANUAL — FRONT TO BACK

This TM supplement is divided into front and rear matter and Work Packages (WPs) for ease of use.

The WARNING SUMMARY section provides safety and first aid information. This section includes general warnings not found in the TM text and a list of the most important detailed warnings extracted from the WPs. All of these warnings cover hazards that could kill or injure personnel.

The TABLE OF CONTENTS lists the WPs.

CHAPTER 1 covers general introductory information with theory of operation. The Equipment Description WP gives a brief description of major parts and features of the carriers. The Theory of Operation WP provides information that will help you understand how the carrier components work.

CHAPTER 2 covers troubleshooting procedures authorized at the DS/GS maintenance level.

CHAPTER 3 includes general maintenance procedures for service upon receipt, PMCS, and general maintenance instructions.

CHAPTER 4 contains maintenance WPs for the fuel system.

CHAPTER 5 contains maintenance WPs for the cooling system.

CHAPTER 6 contains maintenance WPs for the electrical system.

CHAPTER 7 contains maintenance WPs for the transmission.

CHAPTER 8 contains maintenance WPs for the wheels and tracks.

CHAPTER 9 contains maintenance WPs for steering.

CHAPTER 10 contains maintenance WPs for the shock absorbers.

CHAPTER 11 contains maintenance WPs for the hull.

CHAPTER 12 contains maintenance WPs for the hull accessory items.

CHAPTER 13 contains maintenance WPs for the hydraulic system.

CHAPTER 14 contains maintenance WPs for tools and test equipment.

CHAPTER 15 contains maintenance WPs for the auxiliary generator.

CHAPTER 16 contains maintenance WPs for special purpose kits.

CHAPTER 17 — Deleted

CHAPTER 18 contains maintenance WPs for electrical equipment (M1068A3 only).

CHAPTER 19 contains maintenance WPs for precision instruments and systems.

CHAPTER 20 contains maintenance WPs for fire fighting equipment.

CHAPTER 21 contains maintenance WPs for the shipping closure and frame.

CHAPTER 22 contains general support maintenance WPs.

CHAPTER 23 provides supporting information for the TM. It includes the following WPs:

The REFERENCES WP lists references to be used by personnel in operating and maintaining the carrier.

The COMMON TOOLS and SUPPLEMENTS and SPECIAL TOOLS/FIXTURES WP lists the tools used in the initial setup.

The EXPENDABLE/DURABLE SUPPLIES and MATERIALS lists the expendable supplies and materials used to maintain or repair the carrier.

HOW TO USE THIS MANUAL (cont)

The FABRICATED TOOLS WP lists instructions for making tools authorized to be fabricated at DS or GS maintenance levels.

The INDEX is an alphabetical listing of all the tasks in the WPs of this TM. Each entry is cross-referenced to the WP number and page number.

DA FORM 2028–2 is used to report errors and to recommend improvements for procedures in this manual. Three blank DA Forms 2028–2 are in the back of this manual. A sample is provided to show you how to fill out the DA Form 2028–2.

The back cover includes a METRIC CONVERSION CHART that can be used to convert U.S. customary measurements to their metric equivalents. Measurements in this manual are given in U.S. customary unit with metric units in parentheses.

HOW TO USE THE WORK PACKAGES

How to find the WP you need

Pick a key word from the carrier part or system to be used during the WP. Look in the INDEX for this key word or the name of the action you will perform. The INDEX lists each WP under one or more headings. Turn to the page indicated.

How to read the WP

Be sure to read all **warnings**, **cautions** and **notes**. These are in all types of WPs. They help you avoid harm to yourself, other personnel and equipment. They also tell you things you should know about the WP.

Before starting, get all tools, supplies, and personnel, listed on the setup page needed to do the WP. Be sure to read the WP before performing the maintenance. If any other WPs are referenced, you must go to the setup page for each of those WPs to find out what tools, parts, and materials will be needed.

Start with step 1 and do each step in given order.

Look at the drawings. These show you what to look for when reading a maintenance WP.

Maintenance Instructions WPs

Doing maintenance WPs will keep the carrier in shape to operate. Maintenance WPs are used to present maintenance instructions. Each maintenance WP details steps which you need to perform. If the carrier and parts need maintenance that is not included in any WP in the manual, report this to your supervisor.

Read the INITIAL SETUP section carefully before you start a WP. Get the tools and supplies listed and the personnel needed to perform the WP. Be sure that the equipment is in the condition required.

DEFINITION OF WP TERMS

WARNINGS, CAUTIONS, AND NOTES

Be sure to read all warnings and cautions in the WP. Ignoring a warning could cause death or injury to yourself or other personnel. Ignoring a caution could cause damage to equipment. Notes contain facts to make the WP easier. Warnings, cautions, and notes always appear just above the WP step to which they apply.

WARNINGS

Call attention to things that could kill or injure personnel. Warnings are also listed in the Warning Summary .

CAUTIONS

Call attention to actions or materials that could damage equipment.

NOTES

Contain important facts to make the procedure easier.

HELPER

Helpers are needed for WPs that require more than one person such as lifting heavy objects or acting as an observer.

HOW TO USE THIS MANUAL (cont)

If a helper is needed to perform a procedure, the INITIAL SETUP will list “Helper” under the PERSONNEL REQUIRED heading.

If helper assists with a step, the step will include: “Have helper assist”.

If a helper performs the action alone, the step will start with “HELPER”.

The terms “front”, “rear”, “left”, and “right” are used to indicate where items are located. The POINT OF REFERENCE FOR THESE TERMS IS DIFFERENT FOR CARRIER ITEMS AND POWER UNIT ITEMS. (Carrier items are items which are not on the power unit. Power unit items are items on the engine or transmission).

If you are working with carrier items, use this point of reference. Think of the location as if you were sitting in the driver’s seat looking out the hatch.

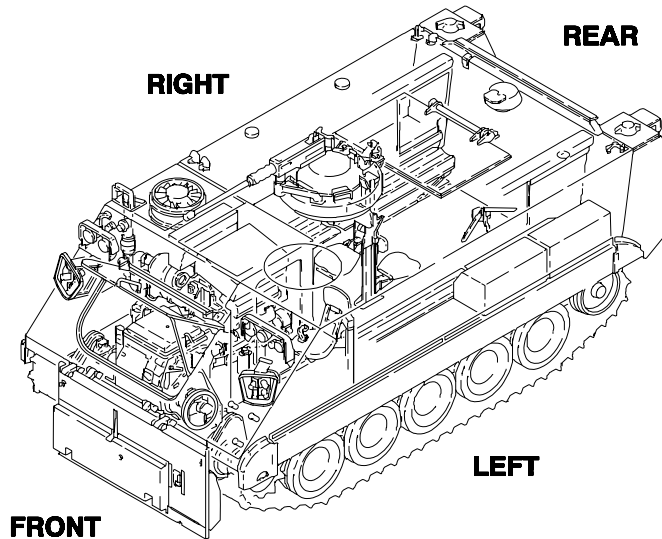

If you are working with power unit items, use this point of reference. Think of the locations as if you were standing at the transmission end of the power unit and facing the flywheel. This rule applies whether the power unit is IN or OUT of the carrier.

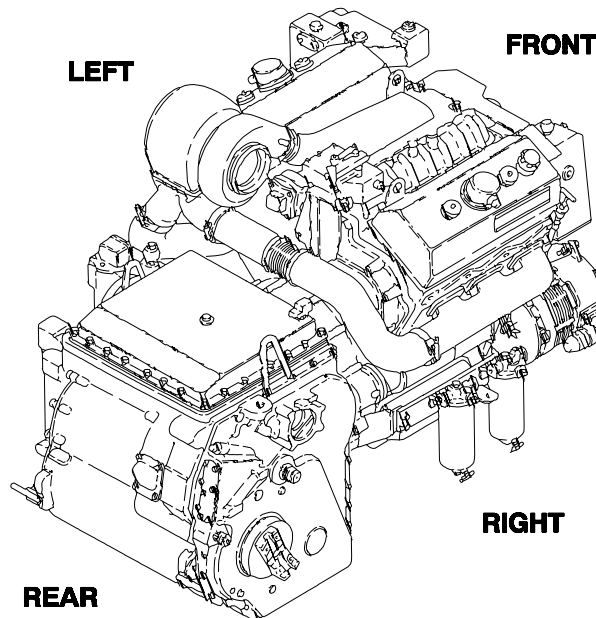

References within a WP refer to a different manual or to another WP in the same manual. A step in one WP may be a complete WP someplace else. Below is an example of a reference step from the WP: INSTALL ENGINE COOLANT HEATER KIT.

Example: Lower power plant grill (see your -20).

The tools needed to do the task will be listed in that task.

For all WPs, the following comments apply:

HOW TO USE THIS MANUAL (cont)

Parts which are listed on the setup page will be referred to as “new” in the WP setup when installed.

Examples are: “locknuts”, “lockwashers”, “cotter pins”, and some “gaskets”.

These and other new parts are listed under MATERIAL/PARTS in the initial set up.

Cleaning, inspecting, checking for leaks, and similar procedures which apply to most WPs are found in CHAPTER 3, GENERAL MAINTENANCE PROCEDURES. Use these steps to clean and inspect any part being removed, repaired, or installed. Special cleaning will be covered in the WP step.

The RPSTL TM 9-2350-277-24P gives the National Stock Number (NSN) required to order parts use in the maintenance WPs.

To use the RPSTL to identify and order a part, do the following:

In this manual, turn to the first page of the WP to be performed.

Find Materials/Parts under INITIAL SETUP, and read the part(s) that need replacement. If required, find the illustrated part in the WP steps.

Go to the RPSTL and find the same illustrated part. That part will have an item number assigned to it. Look this item number up in the listing for that figure. The NSN can be found in the National Stock Number and Part Number Index in the back of the RPSTL.

If you inspect an item and find that it is damaged, go to the RPSTL and find the SMR code for the item. If the SMR code does not authorize you to repair the item, reassemble it and send it to the authorized level of maintenance.

CHAPTER 1

GENERAL SUPPORT INTRODUCTORY INFORMATION WITH THEORY OF OPERATION

WORK PACKAGE INDEX

<u>Title</u>	<u>Sequence No.</u>
GENERAL INFORMATION.....	.0001 00
EQUIPMENT DESCRIPTION.....	.0002 00
THEORY OF OPERATION.....	.0003 00
REPAIR PARTS, SPECIAL TOOLS, TMDE, AND SUPPORT EQUIPMENT.....	.0004 00

GENERAL INFORMATION

0001 00**SCOPE**

Type of Manual: Direct and General Support Maintenance

Equipment Model Number, Name, and Purpose:

M113A3 – Armored Full Tracked Personnel Carrier

Purpose: Transportation and positioning combat troops and supplies.

M577A3 – Light Tracked Command Post Carrier

Purpose: Provides protection and mobility for field commanders in a tactical environment.

M1059A3 – Full Tracked Smoke Generator Carrier

Purpose: Designed to generate a smoke screen in the battlefield environment.

Other Applicable Manuals: See TM 3-1040-283-20&P for Operator's instructions, Unit maintenance, and repair parts for Smoke Generator Set M157A2.

M1064A3 – Self-propelled 120-mm M121 Mortar Carrier

Purpose: Provides mobility for the 4.7-inch (120-mm) Mortar M121 or M120. The M121 can be fired from a turntable mounted in the carrier. The M120 can be fired from a portable mount off the carrier.

Other Applicable Manuals: See TM 9-1015-250-23 and TM 9-1015-250-23P for Unit and DS maintenance and repair parts for the 4.7-inch (120-mm) Mortar M121 or M120.

M1068A3 – Standardized Integrated Command Post System (SICPS) Carrier

Purpose: Designed as a command post and field office to support the various configurations and installation layouts of the Army Tactical Command and Control System (ATCCS) and provide protection for field commanders in a tactical environment.

Other Applicable Manuals: See TM 11-7010-256-12&P for Operator's instructions, Unit maintenance, and repair parts for SICPS Equipment.

See TM 10-5410-229-13&P for Operator's instructions, Unit and DS maintenance, and repair parts for the Modular Command Post System (MCPS) tent and related parts.

M58—Mechanized Smoke Obscurant Chassis

Purpose: Designed to provide large area smoke screens in support of various tactical situations. Smoke can be generated in a static position or on the move.

Other Applicable Manuals: See TM 3-1040-285-10 for Operator's instructions for the Mechanized Smoke Obscurant System Smoke Generator.

See TM 3-1040-285-20 for Unit Maintenance for the Mechanized Smoke Obscurant System Smoke Generator.

See TM 3-1040-285-30 for Direct Support Maintenance for the Mechanized Smoke Obscurant System Smoke Generator.

See TM 3-1040-285-23P for repair parts for the Mechanized Smoke Obscurant System Smoke Generator.

MAINTENANCE FORMS, RECORDS, AND REPORTS

Department of the Army forms and procedures used for equipment maintenance will be those prescribed by DA Pamphlet 738-750, The Army Maintenance Management System (TAMMS).

REPORTING EQUIPMENT IMPROVEMENT RECOMMENDATIONS (EIR)

If your carrier needs improvement, let us know. Send us an EIR. You, the user, are the only one who can tell us what you don't like about your equipment. Let us know why you don't like the design. Put it on an SF 368 (Quality Deficiency Report). Mail it to us at: Commander, US Army Tank-Automotive Command, ATTN: AMSTA-QRT, Warren, MI 48397-5000. A reply will be sent to you.

DESTRUCTION OF ARMY MATERIEL TO PREVENT ENEMY USE

See the following technical manuals for information on destruction of Army materiel:

TM 750-244-2 Procedures for Destruction of Electronics Materiel to Prevent Enemy Use.

TM 750-244-5-1 Procedures for Destruction of Conventional Ammunition and Improved Conventional Munitions to Prevent Enemy Use.

TM 750-244-6 Procedures for Destruction of Tank Automotive Equipment to Prevent Enemy Use.

TM 750-244-7 Procedures for Destruction of Equipment in Federal Supply Classifications 1000, 1005, 1010, 1520, 2530, 5590, 5595 to Prevent Enemy Use.

PREPARATION FOR STORAGE OR SHIPMENT

For information about administrative storage or shipment, see the following documents:

Preparation for Storage or Shipment

Specification	Applicable Carriers
MIL-C-45360G(AT)	M113A3, M1059A3, M1064A3
MIL-C-46746E(AT)	M577A3 & M1068A3

NOMENCLATURE CROSS-REFERENCE

This listing includes nomenclature cross references used in this manual.

COMMON NAME

Locknut	Self-locking nut
Lockscrew	Self-locking bolt
Lockwasher	Self-locking washer

METRIC EQUIVALENTS

Metric equivalents are used throughout this manual. Metric symbols and units are:

Metric Equivalents

SYMBOL	UNIT
C	Celsius
cc	cubic centimeter
cm	centimeter
j	joule
kg	kilogram
kg/min	kilogram per minute
km	kilometer
km/h	kilometer per hour
kPa	kilopascal
kW	kilowatt
l	liter
m	meter
mm	millimeter
N·m	Newton-meters

SAFETY, CARE, AND HANDLING

See Warning Summary in front of manual.

EQUIPMENT DESCRIPTION

0002 00**EQUIPMENT CHARACTERISTICS, CAPABILITIES, AND FEATURES**

For equipment characteristics, capabilities, and features, see your -10.

LOCATION AND DESCRIPTIONS OF MAJOR COMPONENTS**ENGINE**

A turbocharged diesel engine is located in the power plant compartment.

TRANSMISSION

An automotive transmission connects to the engine and powers the final drives.

FINAL DRIVES

Final drives attach to the transmission by propeller shafts. They deliver power to drive sprockets at the front of the carrier.

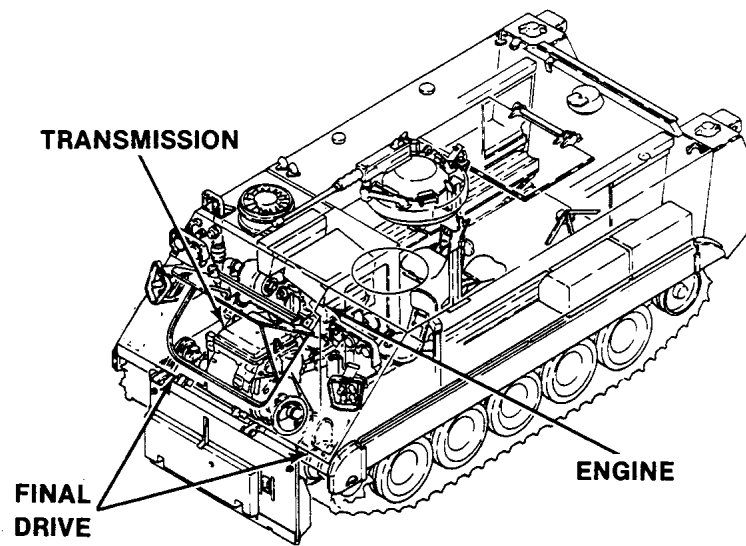

TRACKS AND SUSPENSION

Drive sprockets are at the front of the carrier drive track. Torsion bars and shock absorbers attach to road wheels and provide suspension.

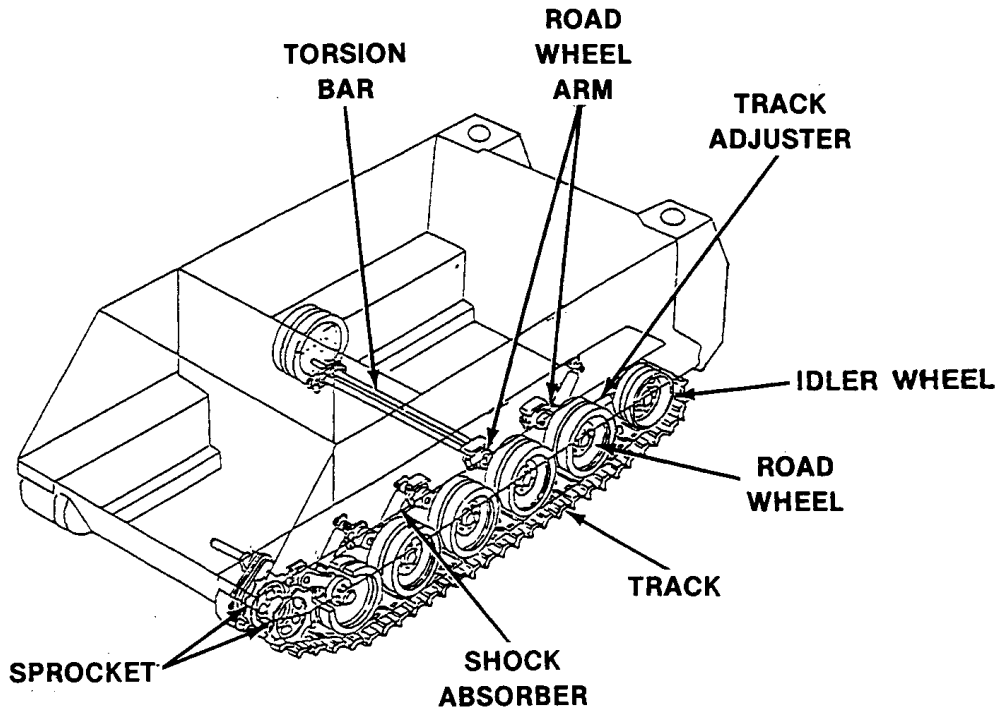

ELECTRICAL

Four batteries connected in a parallel-series arrangement supply electricity through the distribution box to the carrier. On the M113A3, M1059A3, and M58 carriers, the four batteries are located on the left sponson. On the M577A3 and M1068A3 carriers, the four batteries are located on the right sponson next to the personnel heater. On the M1064A3 carrier, two batteries are located in a drawer on the left sponson behind the driver and two batteries are located under the right personnel seat.

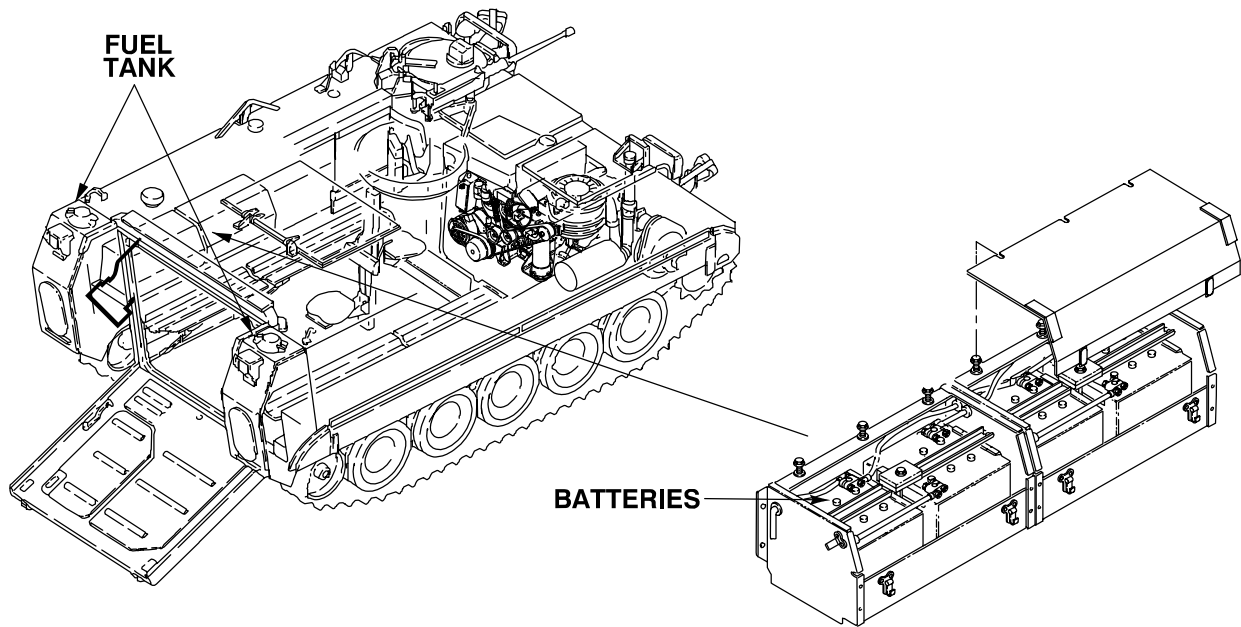

M113A3 AND M1059A3 SHOWN

**FUEL SYSTEM**

The M113A3, M1059A3, M1064A3, and M58 carriers have two external fuel tanks located at the rear of the carrier on each side of the ramp. Total capacity is 95 gallons. The M577A3 and M1068A3 carriers have two internal fuel tanks located on the rear left and right sponsons. Total capacity is 120 gallons.

EXHAUST SYSTEM

The exhaust system drives the turbocharger and carries exhaust gases through manifolds and the muffler.

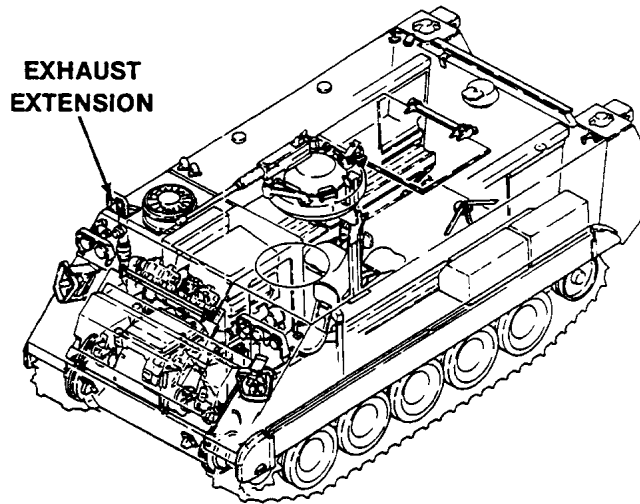
**DIFFERENCES BETWEEN CARRIERS**

This manual covers seven different carriers. For a list of differences between carriers, see the DIFFERENCES chart in your -20.

EQUIPMENT DATA

For equipment data, see your -10.

THEORY OF OPERATION

0003 00**SCOPE**

This section describes the functions of the hull system. Also it describes the power plant, auxiliary automotive system, suspension and electrical systems, and special equipment.

POWER PLANT

The diesel engine and transmission are major parts of the power plant. The dc generator, exhaust, cooling, and engine air systems are support systems for the power plant.

DIESEL ENGINE

The diesel engine is the primary source of power for the carrier. The engine changes air and diesel fuel into energy and delivers this power to the transmission. The diesel engine consists of three major systems: fuel, oil, and starting.

In the fuel system, diesel oil is stored in the fuel tanks. The fuel is drawn through one filter and pumped through the other filter to the engine. The injectors force fuel into combustion cylinders where it is mixed with air and changed into energy.

The oil system provides lubrication for the engine. Oil is cycled throughout the engine by a pump. The pump is located at the lower front of the engine. An oil filter cleans the oil, and an oil cooler reduces oil temperature.

The engine is equipped with a heavy duty starter. The starter, with built in solenoid, is used to crank the engine for starting.

TRANSMISSION

The carrier uses a hydromechanical transmission with hydrostatic steering. The transmission has its own oil system with filters and separately mounted oil cooler. This transmission oil system is separate from the engine oil system.

The transmission delivers power from the engine to the left and right final drives. The left and right final drives are driven by propeller shafts. The final drives deliver power to drive sprockets in the suspension system.

DC GENERATOR

The dc generator is part of the carrier electrical system. It is driven directly by engine power. The generator charges the batteries in the carrier when the engine is running. A regulator mounted near the driver keeps the voltages at the correct level.

EXHAUST SYSTEM

Major exhaust system parts are the turbocharger, exhaust manifolds, and muffler.

The turbocharger is driven by exhaust gases from the engine. The turbocharger helps the engine develop more power and operate more efficiently. The exhaust manifolds carry the exhaust gases to the turbocharger from the engine. The muffler cuts down engine noise and allows exhaust to escape outside the carrier.

COOLING SYSTEM

The cooling system cools the engine and transmission. It consists of a fan, fan drive, fan speed control assembly, radiator, coolant pump, auxiliary tank, transmission oil cooler, engine oil cooler, and thermostats. The cooling system contains approximately 53 quarts of liquid coolant. The liquid coolant is cycled through the engine and transmission oil cooler by the coolant pump. This process keeps the engine and transmission temperature in a safe operation range.

As coolant flows through the engine, it absorbs heat from the engine and transmission oil coolers. The heated coolant then flows to the radiator to remove coolant heat. The coolant fan pulls outside air in and through the radiator to remove heat. The fan is powered by the engine through a fan drive.

The variable speed fan drive system is designed to modulate the cooling fan speed to maintain relatively constant coolant temperatures despite vehicle load or ambient temperature. The cooling fan speed is controlled by the fan drive assembly. The fan drive assembly is driven by the engine crankshaft through a splined coupling. The fan drive assembly contains a multi-plate clutch pack which regulates the fan drive output speed. In the old variable speed fan drive configuration, the thermostatic control valve senses engine coolant temperature and regulates the hydraulic pressure to the fan drive assembly clutch pack. The higher the coolant temperature, the higher the hydraulic pressure which will result in less clutch slip and higher fan speed. The new variable speed fan drive configuration is electromagnetically controlled. The new configuration uses the same process of changing pressure plates, locking up or releasing to speed up or slow down the fan. The variable speed fan drive is electromagnetically regulated by the electronic controller which receives information from switches and sensors. This allows the cooling system to operate efficiently so full power is not required. The electronic controller has diagnostic capability to help the crew and maintenance personnel in troubleshooting the variable speed fan drive and cooling system.

The surge tank acts as an overflow tank to keep the cooling system from overpressurizing. It also removes air from the engine coolant. There is a low coolant level transmitter to signal the operator if more coolant is needed.

ENGINE AIR SYSTEM

The engine air system allows air to enter the engine. The air cleaner cleans air that enters the engine. Dust is drawn out through a scavenge outlet. Air is filtered through a reusable filter element before delivery to the engine. An air filter indicator shows when the element is clogged and needs cleaning or replacing. After being filtered, the air moves through the turbocharger and into the engine cylinders.

AUXILIARY AUTOMOTIVE SYSTEMS

The auxiliary automotive systems include driver controls, fuel cells, personnel heater, and bilge pumps. Also there is a crew ventilation system, and fire suppression system.

DRIVER CONTROLS

The driver controls regulate the engine, transmission, and steering braking systems of the carrier.

The fuel shutoff control is used to stop the supply of fuel to the fuel pump. To start the engine, the driver must open the valve. The throttle linkages are used to control the engine speed. The gear selector allows the driver to choose the proper gear for the carrier. The steering system controls the carrier direction. The steering control consists of a steering yoke and linkage connected to the transmission.

The brake system allows the driver to stop a moving carrier and hold the carrier in position. The braking system consists of the service brake and the parking brake. The service brakes are hydraulic and applied by pedal. The parking brake mechanically locks the transmission to prevent carrier movement. Also, the system has levers, rods, shafts, and linkages connecting to the transmission brake shaft.

FUEL TANKS

Diesel fuel is stored in two separate fuel tanks. They are located on the back of the carrier hull. The fuel is drawn from the fuel tanks through the primary fuel filter by the fuel pump. The fuel then flows through the secondary fuel filter to the injectors. The injectors regulate the amount of fuel that enters the engine.

PERSONNEL HEATER

The personnel heater system provides heat inside the carrier. Major parts are the combination combustion chamber/heat exchanger, blowers, a fuel pump, and an electrical control and safety system. The heater operates using diesel fuel drawn from the fuel tanks. Fuel is delivered to the combustion chamber from the fuel pump. Outside air is drawn into the combustion chamber by one of the blowers. A blower draws air from the crew compartment into the combustion chamber. The air is warmed by heat from the combustion process and then returned to the crew compartment.

BILGE PUMPS

Two electrically driven bilge pumps remove water and other liquids from the hull. Water enters the pumps through a screened inlet. The pumps force water out of the carrier through outlet tubes. The bilge pumps are controlled by a switch on the driver's instrument panel.

HYDRAULIC POWER UNIT

The ramp is raised or lowered by a hydraulic system which consists of a pump, a dual-acting cylinder, a solenoid valve, and a fluid reservoir. This system is controlled by a three position switch located near the driver. Moving the valve to either RAISE or LOWER position directs fluid to the appropriate port on the hydraulic cylinder.

FIRE EXTINGUISHER SYSTEM

The fire extinguisher system will detect and put out fires in the carrier. It consists of two CO₂ (Carbon Dioxide) cylinders. Carbon Dioxide can put out fires quickly and effectively. The cylinders are operated manually by pulling cables located on the hull.

There is a fire extinguisher located in the driver's compartment that is manually discharged. This cylinder discharges into the engine compartment. The other is located in the personnel department.

SUSPENSION SYSTEM

The suspension system supports the carrier and delivers engine power to the road. It allows the carrier to maneuver and be stable. Suspension system parts are the drive sprockets, tracks, idler wheels, track adjuster, road wheels, and road wheel support arms. Also, there are torsion bars and shock absorbers.

The drive sprockets drive the tracks. They are powered by left and right final drives from the transmission. The tracks consist of two flexible chains of track shoes. The tracks ride on the drive sprockets and are guided by idler wheels. The idler wheels can be adjusted to maintain correct track tension.

There are five pairs of road wheels per side. Track centerguides fit between each pair of road wheels. All road wheels are connected to support arms.

ELECTRICAL SYSTEM

The electrical system provides power for the carrier. The system operates on wet cell batteries and includes charging, regulating and monitoring equipment. The batteries provide a normal operating 24 volts with an amperage capability of 200 amps per hour.

The batteries supply the carrier with electricity when the engine is off. All electrical power is delivered through the distribution box except for the engine coolant heater and personnel heater which are directly powered from the batteries. Electrical power flows from the batteries through the distribution box, cables, and wiring assemblies to the hull. The hull is a ground for the electrical system.

The dc generator recharges the batteries and supplies electricity while the engine is running. The dc generator has 200 amps per hour capability.

There are several electrical subsystems within the hull. Each subsystem contains at least one wiring assembly. Major electrical subsystems and assemblies include the interior and exterior lights, fuel supply, starting and charging systems, ventilation, heating, and bilge pumps.

WINTERIZATION EQUIPMENT

■ Personnel heaters are standard equipment on M577A3, M1068A3, and M58 carriers, but are kit items on M113A3, M1059A3, and M1064A3 carriers. Since maintenance of heater components is the same for both standard heaters and kit heaters, they are only covered in one place in this manual. See Table of Contents for maintenance of heater components.

REPAIR PARTS, SPECIAL TOOLS, TMDE, AND SUPPORT EQUIPMENT

0004 00**COMMON TOOLS AND EQUIPMENT**

For authorized common tools and equipment, see the Modified Table of Organization and Equipment (MTOE) for your unit. Common tools and equipment needed for the maintenance procedures in the manual are listed in Appendix B.

SPECIAL TOOLS, TMDE, AND SUPPORT EQUIPMENT

Special tools, TMDE, and support equipment needed for the maintenance procedures in this manual are listed in Appendix B. Special tools are also cataloged in the Repair Parts and Special Tools List (RPSTL) TD 9-2350-277-24P. Additional TMDE and special tools are listed in your -20.

NOTE

More than one model of multimeter is available to you in the supply system. You may use any model available.

FABRICATED TOOLS

Some tools needed for specialized maintenance procedures are not available in the supply system. These tools are normally fabricated locally by the unit doing the maintenance. Fabrication instructions for these tools are given in Appendix D.

REPAIR PARTS

Repair parts are listed and illustrated in the Repair Parts and Special Tools List (RPSTL) TD 9-2350-277-24P. Maintenance and supply personnel can order them.

CHAPTER 2

GENERAL SUPPORT TROUBLESHOOTING PROCEDURES

WORK PACKAGE INDEX

<u>Title</u>	<u>Sequence No.</u>
INTRODUCTION TO HOW TO USE TROUBLESHOOTING.....	0005 00
MALFUNCTION/SYMPTOM INDEX WP.....	0006 00
VEHICLE BATTERIES DISCHARGE WITH EXTERNAL AC POWER APPLIED (M1068A3 ONLY).....	0007 00
VEHICLE WILL NOT ACCEPT EXTERNAL AC POWER (M1068A3 ONLY).....	0008 00
NO DC OUTPUT FROM DC POWER SUPPLY (M1068A3 ONLY).....	0009 00
PATCH PANEL BOX A10 INOPERATIVE (M1068A3 ONLY).....	0010 00
EXTERNAL COMMUNICATION BOX A11 INOPERATIVE (M1068A3 ONLY).....	0011 00
PATCH PANEL BOX A10.....	0012 00

INTRODUCTION TO HOW TO USE TROUBLESHOOTING

0005 00**PURPOSE**

The purpose of direct and general support maintenance level troubleshooting is to diagnose carrier problems which are reported to direct and general support maintenance. Troubleshooting tasks in this manual are common to all M113A3 FOV carriers except where indicated. You should not begin direct and general support maintenance troubleshooting until all operator and unit troubleshooting has been completed. You will perform four actions in direct and general support maintenance troubleshooting:

Before starting a troubleshooting task, verify that reported problem is present in carrier.

After verifying the symptom, find the part that is causing problem.

Replace or adjust that part.

Check to make sure problem no longer exists, and that there are no other problems.

DEFINITIONS AND DESCRIPTIONS OF TROUBLESHOOTING PARTS

Troubleshooting tasks always have a beginning and an end. You will use task steps, test procedures, indexes, maintenance tasks, and other technical manuals to troubleshoot. Troubleshooting uses the following terms that are not used in other kinds of tasks:

FAULT:	The part that is not operating correctly and is causing the problem.
SYMPTOM:	The problem reported by unit maintenance.
VERIFY NO FAULTS FOUND:	After you have completed the corrective action, you must verify that no faults exist. If the fault condition still exists, then the fault is not fixed or there is another fault. If this happens, start at the beginning of the troubleshooting procedure until you find and correct all faults. Always operate the system and/or vehicle to make sure that you have corrected the reported problem. If troubleshooting does not identify a faulty part, the vehicle is defective beyond the level of direct and general support maintenance.

TROUBLESHOOTING BASICS**Troubleshooting Procedure**

A troubleshooting procedure serves as a starting point for your troubleshooting work. You will branch in and out of procedures as you work to find a fault. Also, you will correct the fault, and check that the fault has been corrected.

Locating the Correct Troubleshooting Procedure

Component/carrier arrives at shop.

Read DA Form 2404.

Verify that the problem on DA Form 2404 exists.

Look up carrier symptom in Troubleshooting Task Index and go to that task.

Perform the Troubleshooting Procedure

Make sure you have all items in INITIAL SETUP.

Perform required action(s) in Equipment Conditions.

Complete first block of task steps.

Refer to system schematic or diagram for system components, detail, and clarification.

Answer question at the bottom of the first block.

Follow YES or NO arrows to next block.

Move from block to block. Answer questions and follow instructions. You may be directed to: do further checks and tests on parts; go to another manual and do tasks; or go to another task.

NOTE

After completing the actions called for on another page or manual, return to the point in the troubleshooting procedure where you left off.

Locate fault and perform corrective action.

Check to make sure the fault is corrected, and there are no new faults.

Button up by installing items listed in Equipment Conditions after finishing the troubleshooting task.

MALFUNCTION/SYMPTOM INDEX WP

0006 00

DIRECT SUPPORT TROUBLESHOOTING

HOW TO USE TROUBLESHOOTINGWP 0005 00

VEHICLE BATTERIES DISCHARGE WITH EXTERNAL AC POWER
APPLIED (M1068A3 ONLY)WP 0007 00

VEHICLE WILL NOT ACCEPT EXTERNAL AC POWER (M1068A3
ONLY)WP 0008 00

NO DC OUTPUT FROM DC POWER SUPPLY (M1068A3 ONLY)WP 0009 00

PATCH PANEL A10 INOPERATIVE (M1068A3 ONLY)WP 0010 00

EXTERNAL COMMUNICATION BOX A11 INOPERATIVE (M1068A3
ONLY)WP 0011 00

PATCH PANEL A10 WIRING DIAGRAMWP 0012 00

**VEHICLE BATTERIES DISCHARGE WITH EXTERNAL AC POWER APPLIED
(M1068A3 ONLY)**

0007 00

INITIAL SETUP:

Maintenance Level

Direct Support

Tools and Special Tools

General Mechanic's Tool Kit (WP 0120 00, Item 62)

Digital Multimeter (WP 0120 00, Item 38)

Special Purpose Power Cable
(WP 0121 00, Figure 0121 00-3)

Personnel Required

Power-Generation Equipment Repairer 52D10
Helper (H)

References

See your -10

See your -20

TM 11-7010-256-12&P

M1068A3 wiring diagrams (see your -20)

Equipment Condition

Power control enclosure removed (see your -20)

Power control enclosure power supply cover
removed (see your -20)

Unit level troubleshooting completed (see your -20)

WARNING



HIGH VOLTAGE is used in the operation of this equipment.

DEATH ON CONTACT may result if personnel fail to observe safety precautions.

NEVER work on equipment unless at least one other person familiar with the operation and hazards of the equipment is nearby. That person should also be familiar with giving first aid. When an operator helps a mechanic, that operator must be warned about dangerous areas.

SHUT OFF POWER supply to equipment before beginning work. Make sure all external power is off/disconnected.

BE CAREFUL not to contact high-voltage connections when installing or operating this equipment.

VEHICLE BATTERIES DISCHARGE WITH EXTERNAL AC POWER APPLIED (M1068A3 ONLY)—Continued

0007 00

T

1. Remove jumper cable (1) from terminal J1 (2) on power supply PS1 (3) and terminal J1 (4) on power supply PS2 (5).
2. Measure resistance between terminals (6) of jumper cable (1).
3. Does multimeter read 0 ohms?

NO

TN

1. Replace jumper cable (WP 0090 00).
2. Verify no faults found.

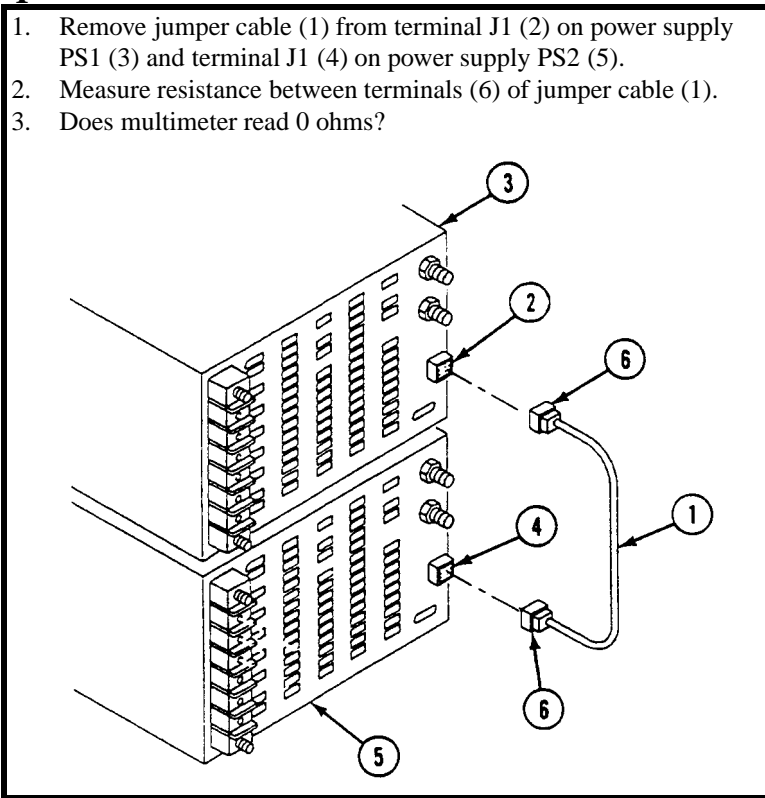

YES

VEHICLE BATTERIES DISCHARGE WITH EXTERNAL AC POWER APPLIED (M1068A3 ONLY)—Continued

0007 00

Y

1. Remove circuit 32D (1) and circuit 31D (2) from power supply PS1 (3) and power supply PS2 (4).
2. Connect Special Purpose Power Cable (5) to external AC power and to J24 (6) on Power Control Enclosure.
3. Set AC MAIN switch and DC POWER SUPPLY switches to ON (see TM 11-7010-256-12&P).
4. Measure voltage between OUTPUT (+) terminal (7) and OUTPUT (-) terminal (8) on power supply PS1 (3).
5. Does multimeter read 26 volts DC or more?

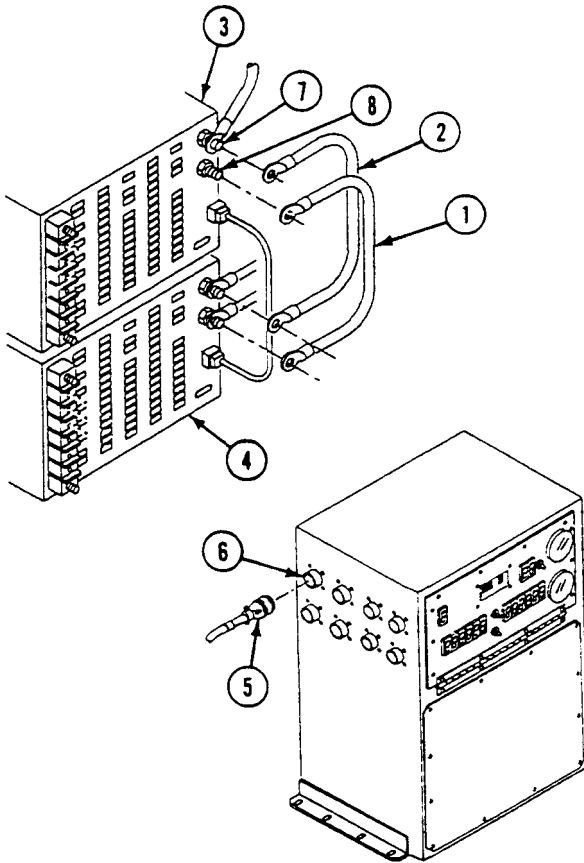

YES

NO

YN

1. Replace power supply PS1 (WP 0090 00).
2. Verify no faults found.

VEHICLE BATTERIES DISCHARGE WITH EXTERNAL AC POWER APPLIED (M1068A3 ONLY)—Continued

0007 00

2Y

1. Measure voltage between OUTPUT (+) terminal (1) and OUTPUT (-) terminal (2) on power supply PS2 (3).
2. Does multimeter read 26 volts DC or more?

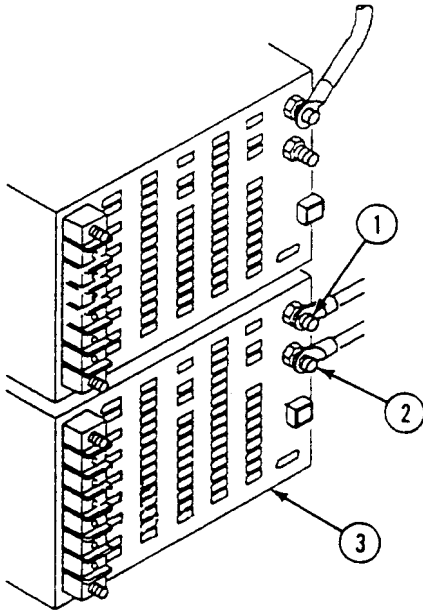

NO

2YN

1. Replace power supply PS2 (WP 0090 00).
2. Verify no faults found.

YES

3Y

1. Measure resistance between terminal ends of circuit 31D (1). Repeat check for circuit 32D (2).
2. Does multimeter read 0 ohms for each measurement?

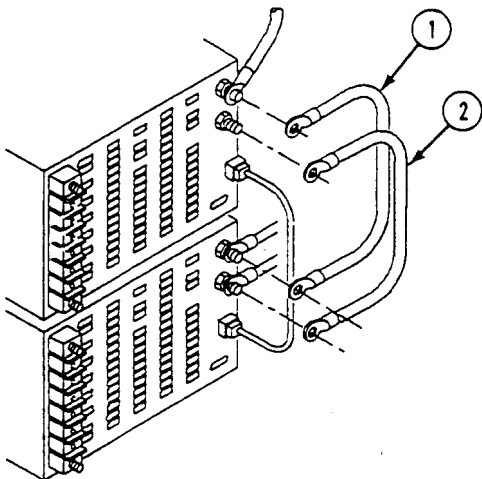

NO

3YN

1. Replace circuit 31D and/or circuit 32D (WP 0090 00).
2. Verify no faults found.

YES

VEHICLE BATTERIES DISCHARGE WITH EXTERNAL AC POWER APPLIED (M1068A3 ONLY)—Continued

0007 00

4Y

1. Disconnect Special Purpose Power Cable (1) from external AC power and from J24 (2) on Power Control Enclosure.
2. Install all circuits (3) on power supplies PS1 (4) and PS2 (5).
3. Remove 10 screws (6) and lockwashers (7) and lower faceplate (8) of Power Control Enclosure. Discard lockwashers.
4. Undo velcro strap (9) securing safety cover (10) over the inside of the faceplate (8). Open safety cover (10).
5. Measure resistance between PS1 (+) OUTPUT terminal (11) and DC bus bar at terminal 1 (12) of circuit breaker CB15 (13).
6. Does multimeter read 0 ohms?

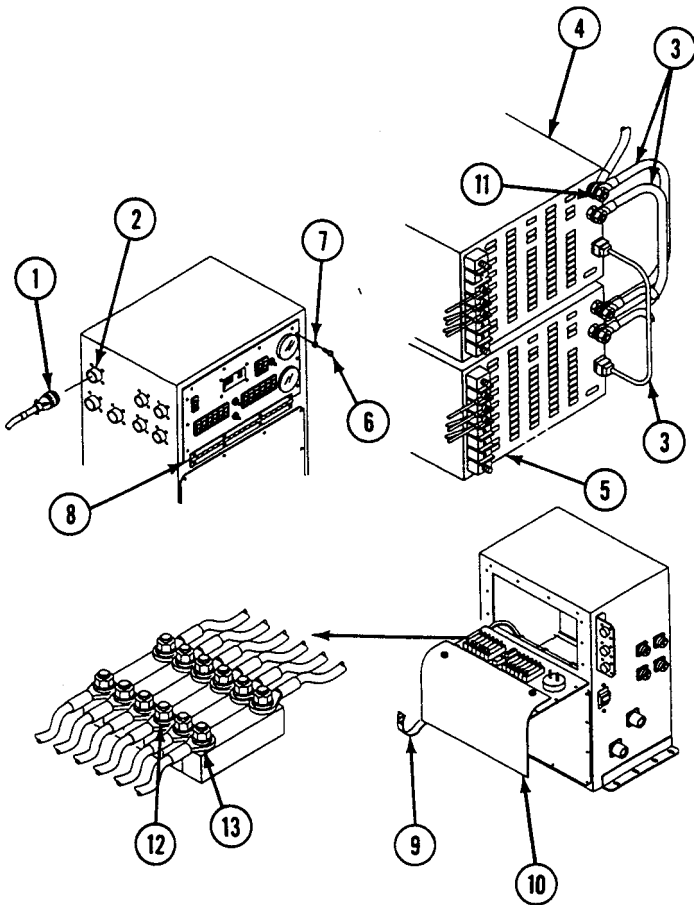

NO

4YN

1. Replace circuit 31E (WP 0090 00) and See your -20.
2. Verify no faults found.

YES

VEHICLE BATTERIES DISCHARGE WITH EXTERNAL AC POWER APPLIED (M1068A3 ONLY)—Continued

0007 00

5Y

1. Measure resistance between power supply PS2 (+) OUTPUT terminal (1) and pin A2 (2) of relay K6 (3).
2. Does multimeter read 0 ohms?

NO

5YN

1. Replace circuit 31C (WP 0090 00) and (WP 0093 00).
2. Verify no faults found.

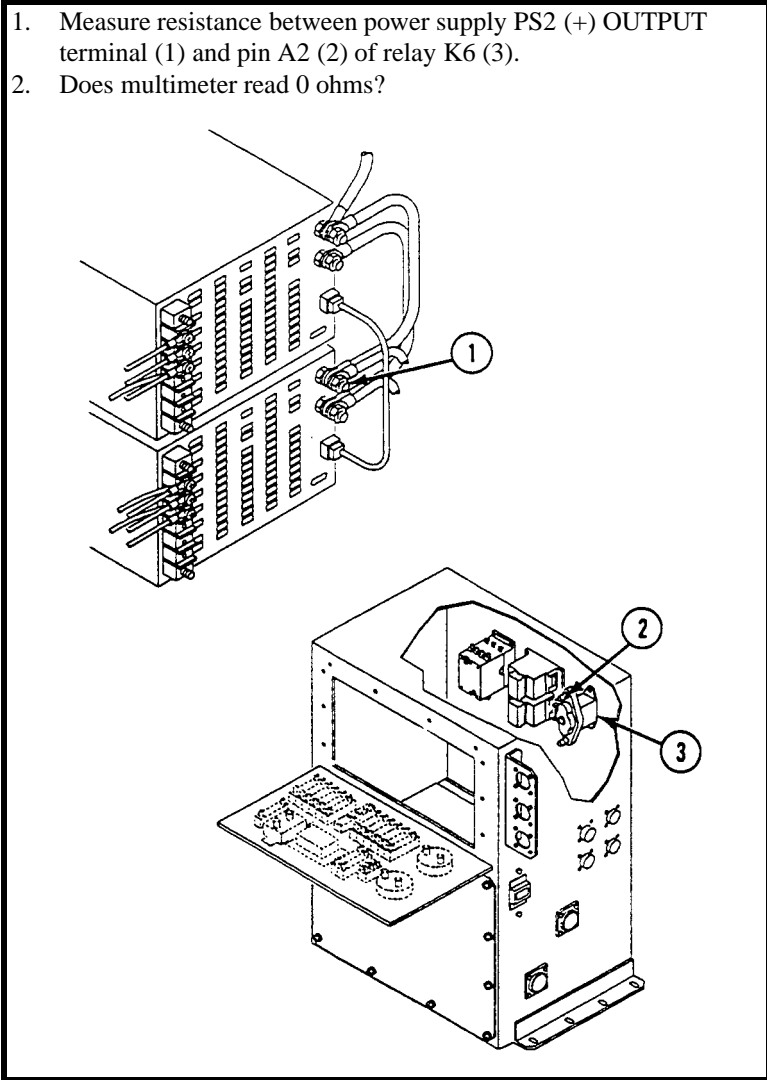

YES

VEHICLE BATTERIES DISCHARGE WITH EXTERNAL AC POWER APPLIED (M1068A3 ONLY)—Continued

0007 00

6Y

1. Remove cable W4 plug P1 (1) from Power Control Enclosure jack J25 (2).
2. Measure resistance between power supply PS2 (-) OUTPUT terminal (3) and jack J25 (2) outer sleeve.
3. Does multimeter read 0 ohms?

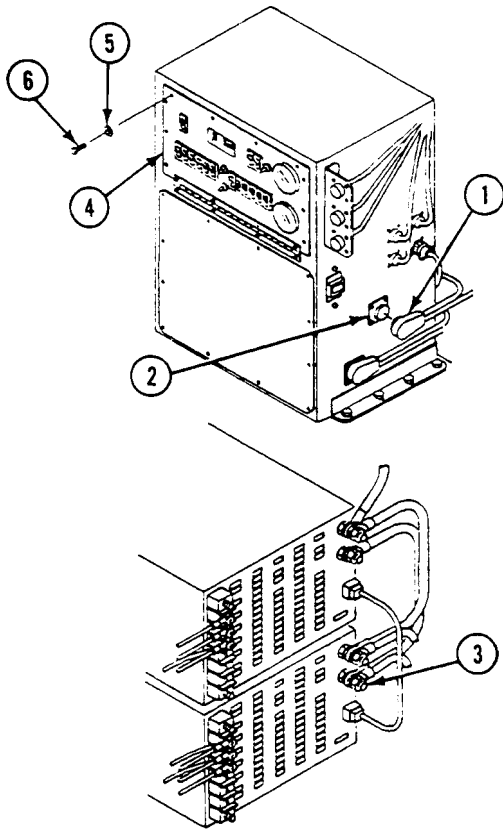

NO

6YN

1. Replace circuit 32E (WP 0090 00) and (WP 0092 00).
2. Install cable W4 plug P1 (1) on Power Control Enclosure jack J25 (2).
3. Raise faceplate (4) and secure to Power Control Enclosure with ten new lockwashers (5) and screws (6).
4. Verify no faults found.

YES

7Y

1. Install cable W4 plug P1 (1) on Power Control Enclosure jack J25 (2).
2. Raise faceplate (4) and secure to Power Control Enclosure with ten new lockwashers (5) and screws (6).
3. Verify no faults found.

VEHICLE WILL NOT ACCEPT EXTERNAL AC POWER (M1068A3 ONLY)

0008 00

INITIAL SETUP:

Maintenance Level

Direct Support

Tools and Special Tools

General Mechanic's Tool Kit (WP 0120 00, Item 62)
 Digital Multimeter (WP 0120 00, Item 38)

Personnel Required

Power-Generation Equipment Repairer 52D10
 Helper (H)

References

See your -10
 See your -20
 TM 11-7010-256-12&P
 M1068A3 wiring diagrams (see your -20)

Equipment Condition

Power control enclosure removed (see your -20)
 Unit level troubleshooting completed (see your -20)

WARNING



HIGH VOLTAGE is used in the operation of this equipment.

DEATH ON CONTACT may result if personnel fail to observe safety precautions.

NEVER work on equipment unless at least one other person familiar with the operation and hazards of the equipment is nearby. That person should also be familiar with giving first aid. When an operator helps a mechanic, that operator must be warned about dangerous areas.

SHUT OFF POWER supply to equipment before beginning work. Make sure all external power is off/disconnected.

BE CAREFUL not to contact high-voltage connections when installing or operating this equipment.

T

1. Remove ten screws (1) and lockwashers (2) and lower faceplate (3). Discard lockwashers.
2. Measure resistance between power enclosure jack J24 pin A (4) and K1 relay terminal T1 (5).
3. Does multimeter read 0 ohms?

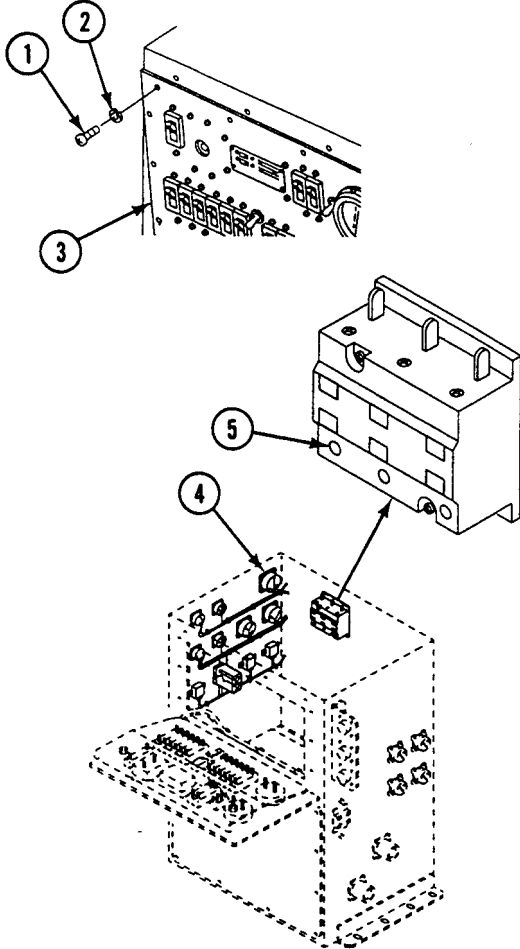

NO

TN

1. Replace lead 1C (WP 0091 00) and (WP 0093 00).
2. Verify no faults found

YES

Y

1. Lift relay bail (1) and remove XK2 relay (2) from relay socket (3).
2. Measure resistance between K1 relay terminal T1 (4) and relay socket terminal 7 (5).
3. Does multimeter read 0 ohms?

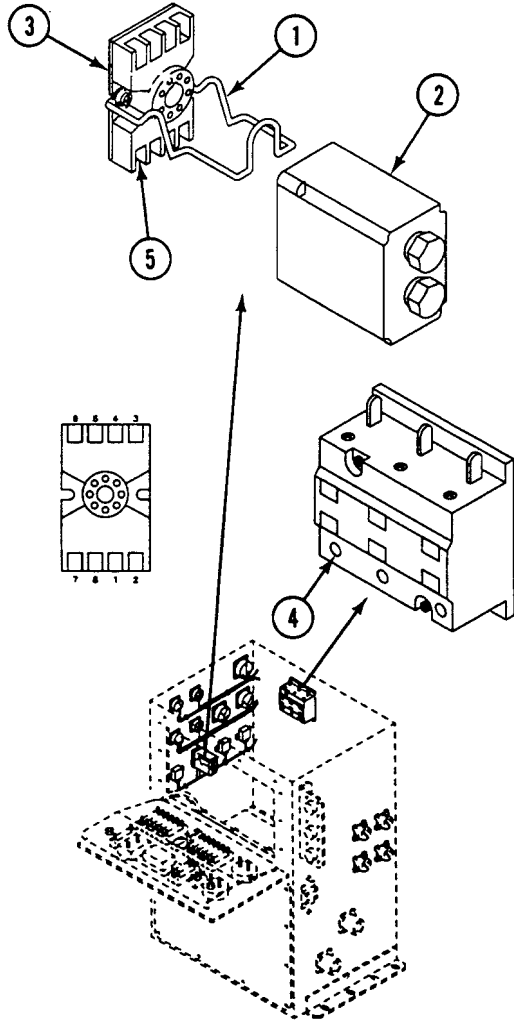

NO

YN

1. Replace lead 1D (WP 0091 00) and (WP 0093 00).
2. Verify no faults found.

YES

2Y

1. Measure resistance between terminal 7 (1) and terminal 1 (2) on XK2 relay socket (3).
2. Does multimeter read 0 ohms?

NO

2YN

1. Replace lead 1E (WP 0091 00).
2. Verify no faults found.

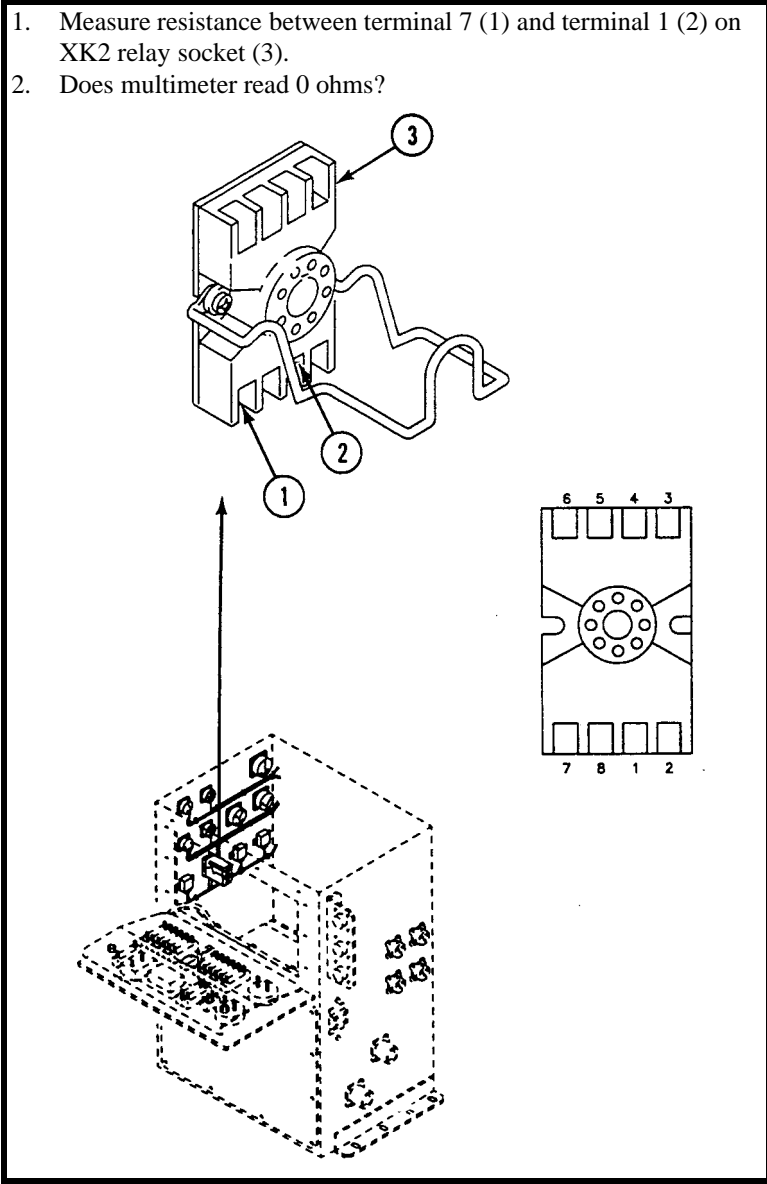

YES

3Y

1. Measure resistance between terminal 7 (1) and terminal 8 (2) on XK2 relay socket (3).
2. Does multimeter read 0 ohms?

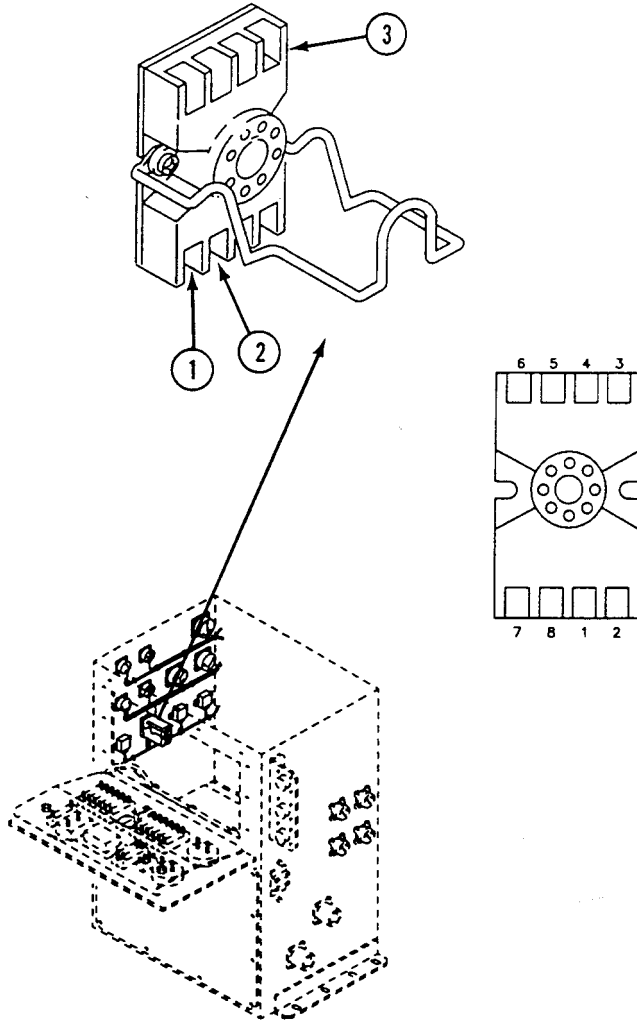

NO

3YN

1. Replace lead 2E (WP 0091 00).
2. Verify no faults found.

YES

4Y

1. Apply external source of AC power to SICPS vehicle (TM 11-7010-256-12&P).
2. Measure voltage between XK2 relay socket terminal 1 (1) and terminal block E4 post 1 (2). Repeat check for terminals 3 (3) and 7 (4) of XK2 relay socket.
3. Does multimeter read 110 volts AC or for each measurement?

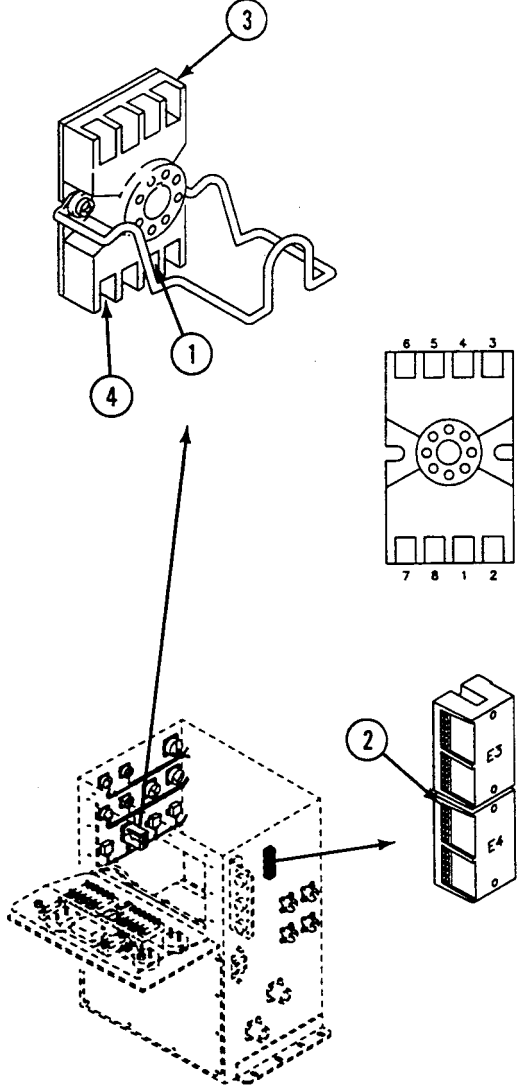

NO

4YN

1. Replace XK2 relay (WP 0091 00).
2. Verify no faults found.

YES

5Y

1. Set external source of AC power to OFF (TM 11-7010-256-12&P).
2. Measure resistance between XK2 relay socket terminal 8 (1) and K1 relay terminal T2 (2).
3. Does multimeter read 0 ohms?

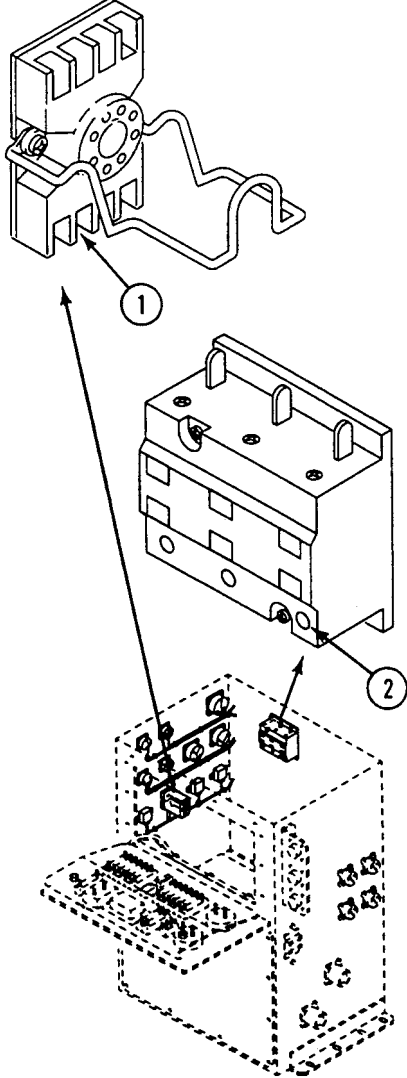

NO

5YN

1. Replace lead 2D (WP 0091 00) and (WP 0093 00).
2. Verify no faults found.

YES

6Y

1. Measure resistance between XK2 relay socket terminal 3 (1) and K3 relay terminal A2 (2).
2. Does multimeter read 0 ohms?

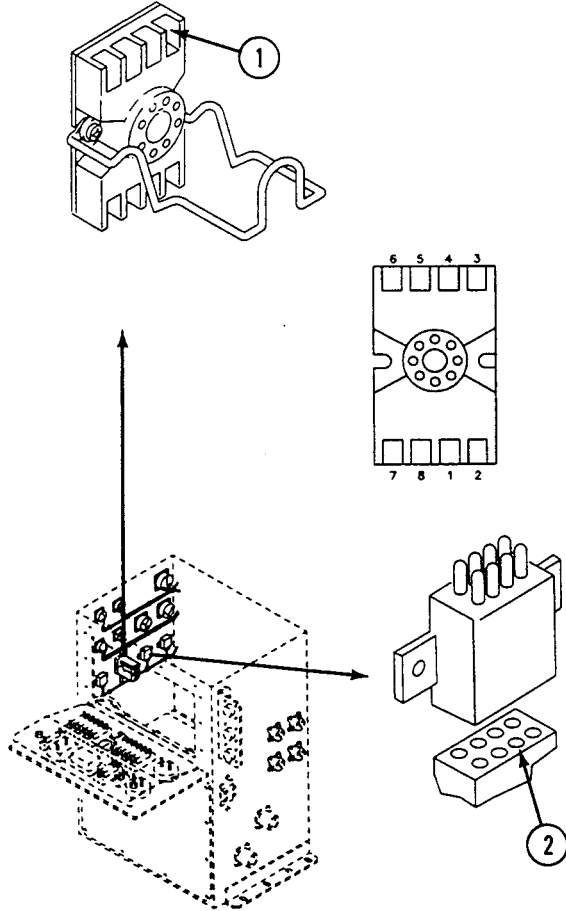

NO

6YN

1. Replace lead 4A (WP 0091 00).
2. Verify no faults found.

YES

7Y

1. Measure resistance between XK2 relay socket terminal 6 (1) and K3 relay terminal X1 (2).
2. Does multimeter read 0 ohms?

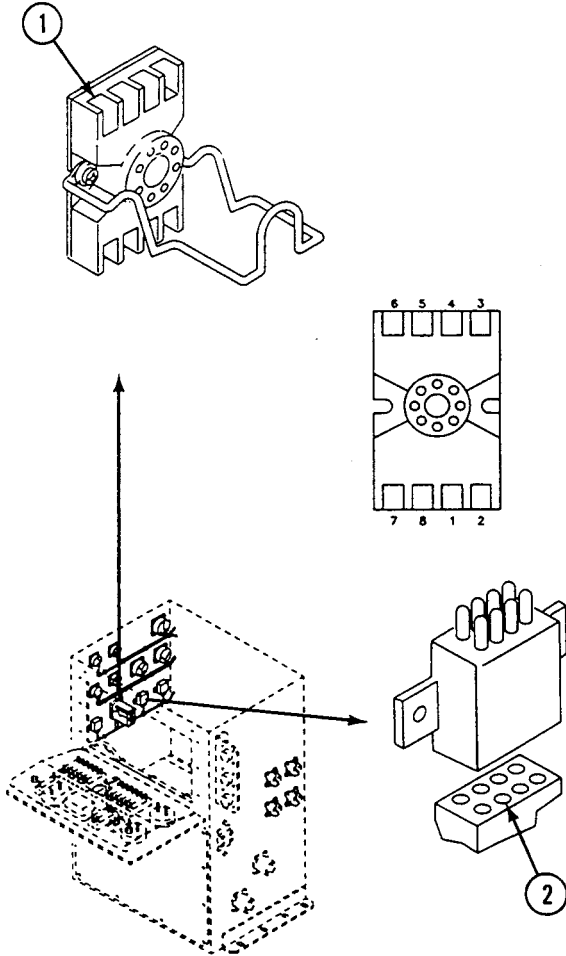

NO

7YN

1. Replace lead 6A (WP 0091 00).
2. Verify no faults found.

YES

8Y

1. Install XK2 relay (1) in relay socket (2) and secure with relay bail (3).
2. Apply external source of AC power to SICPS vehicle (TM 11-7010-256-12&P).
3. Measure voltage between K3 relay terminal A2 (4) and terminal block E4 post 1 (5).
4. Does multimeter read 110 volts AC or for each measurement?

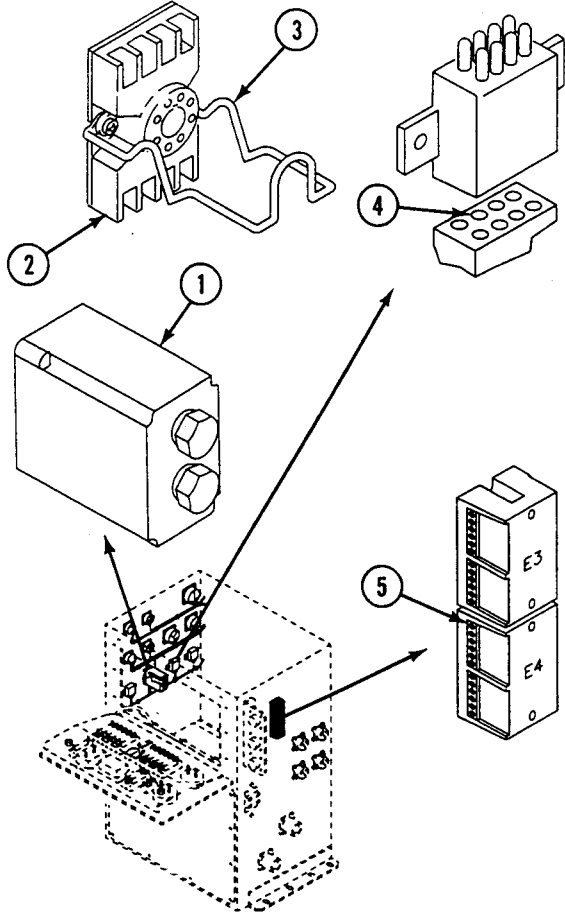

NO

8YN

1. Replace K3 relay (WP 0091 00).
2. Verify no faults found.

YES

9v

1. Measure voltage between K1 relay terminal L1 (1) to anywhere on E4 terminal block (2).
2. Does multimeter read 110 volts AC or more for both measurements?

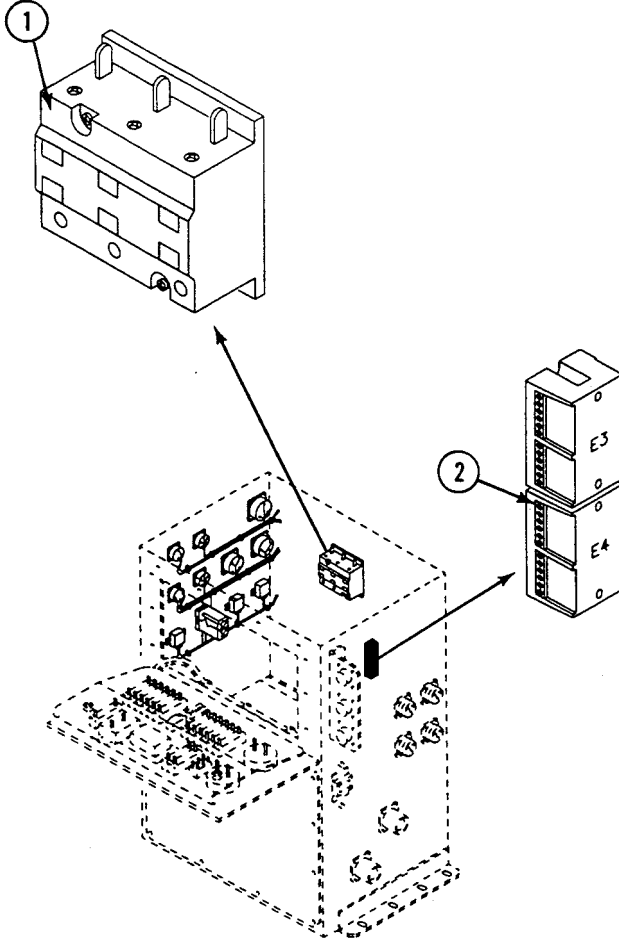

NO

9YN

1. Replace K1 relay (WP 0093 00).
2. Verify no faults found.

YES

10Y

1. Set external source of AC power to OFF (TM 11-7010-256-12&P).
2. Undo the velcro strap (1) securing the safety cover (2) to the inside of the faceplate (3). Pull the safety cover (2) open to access the circuit breakers.
3. Measure resistance between K1 relay terminal L1 (4) and circuit breaker CB1 terminal 1 (5).
4. Does multimeter read 0 ohms?

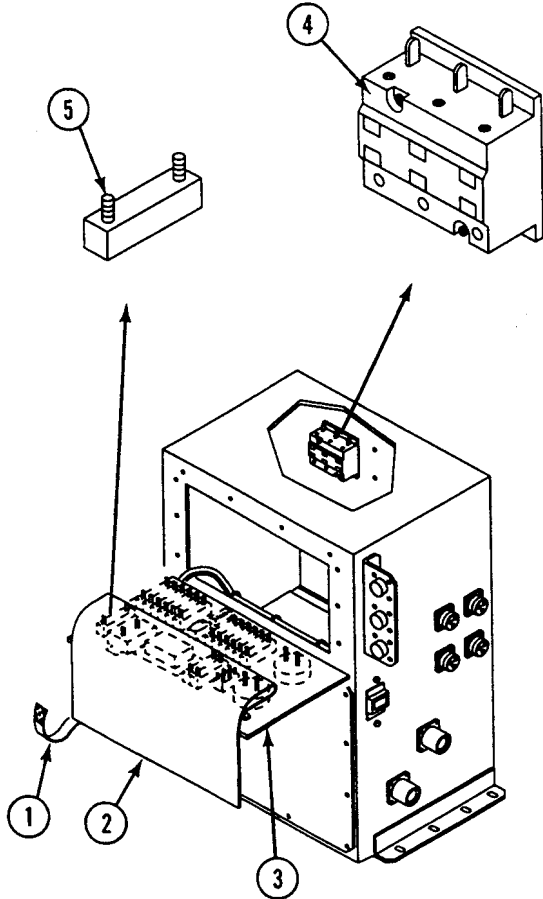

NO

10YN

1. Replace lead 7A (WP 0093 00) and See your -20.
2. Verify no faults found.

YES

11Y

1. Set external source of AC power to ON (TM 11-7010-256-12&P).
2. Set AC MAIN circuit breaker CB1 to ON (TM 11-7010-256-12&P).
3. Measure voltage between CB1 post 2 (1) and terminal block E4 post 1 (2).
4. Does multimeter read 110 volts AC or more?

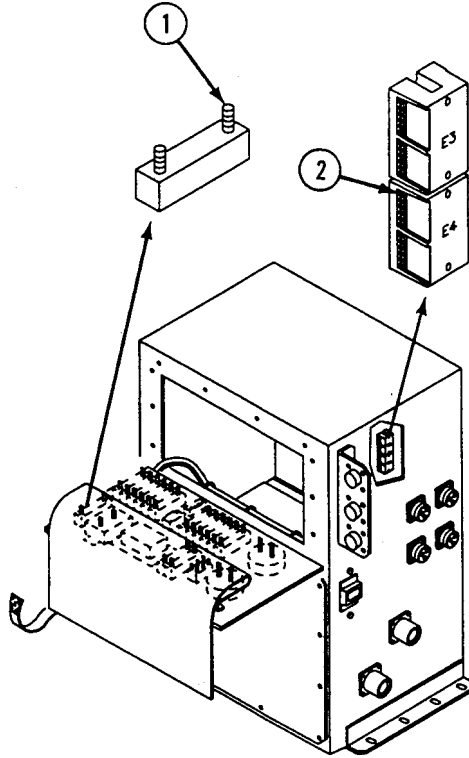

YES



NO

11YN

1. Replace circuit breaker CB1 (see your -20).
2. Verify no faults found.

13Y

NOTE

Use wiring diagram page 0008 00-14.

1. Measure resistance between lead 9C to reversing contactor RC1-FWD terminal L1 (1) and K4 relay terminal X2 (2).
2. Does multimeter read 0 ohms?

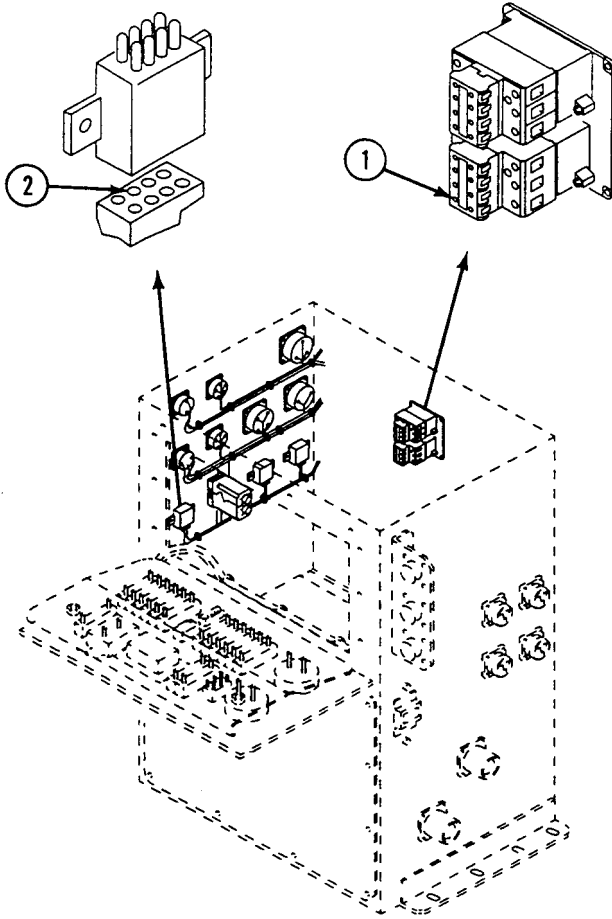

NO

br13YN

1. Replace lead 9C (WP 0091 00) and (WP 0093 00).
2. Verify no faults found.

YES

br14Y

NOTE

Use wiring diagram page 0008 00-14.

1. Measure resistance between K4 relay terminal X1 (1) and lead 8G to reversing contactor RC1-FWD terminal A1 (2).
2. Does multimeter read 0 ohms?

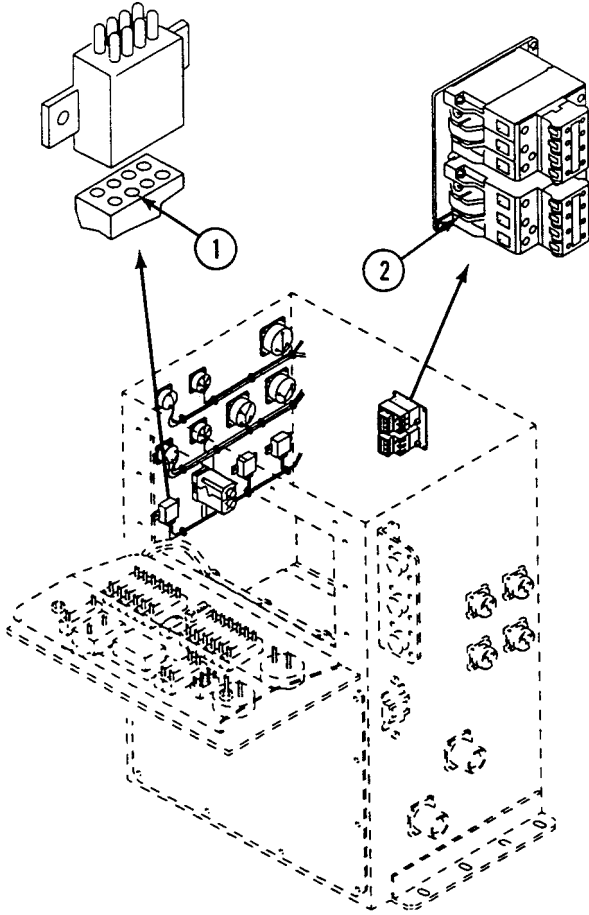

NO

br14YN

1. Replace lead 8G (WP 0091 00) and (WP 0093 00).
2. Verify no faults found.

YES

br15Y

NOTE

Use wiring diagram page 0008 00-14.

1. Measure resistance between jumper lead 8E to reversing contactor RC1-FWD terminal A1 (1) and terminal L2 (2).
2. Does multimeter read 0 ohms?

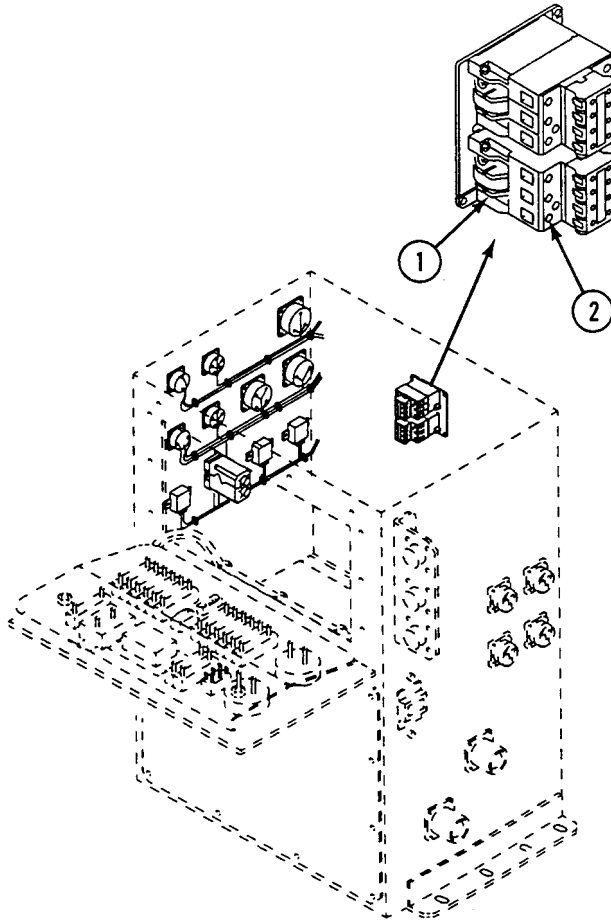

NO

br15YN

1. Replace jumper lead 8E (WP 0093 00).
2. Verify no faults found.

YES

br16Y

NOTE

Use wiring diagram page 0008 00-14.

1. Measure resistance between lead 8A to reversing contactor RC1-FWD terminal L2 (1) to K1 relay terminal L2 (2).
2. Does multimeter read 0 ohms?

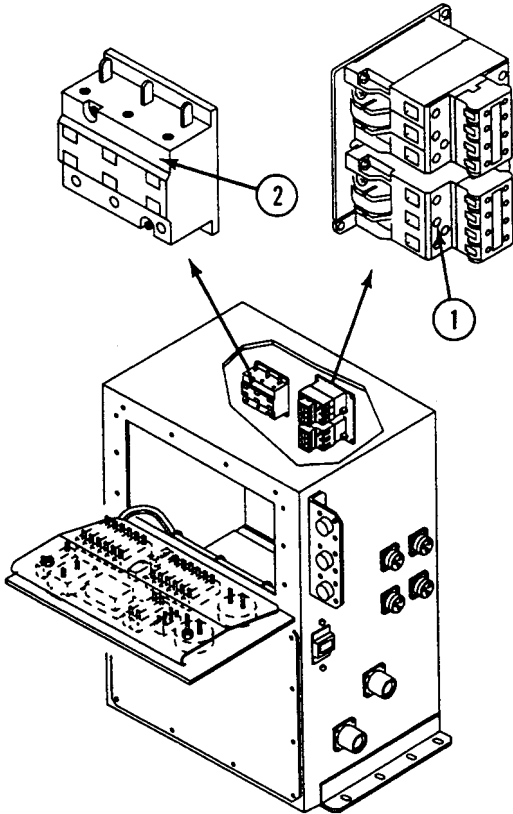

NO

br16YN

1. Replace lead 8A (WP 0093 00).
2. Verify no faults found.

YES

br17Y

NOTE

Use wiring diagram page 0008 00-14.

1. Measure resistance between reversing contactor RC1-FWD terminal A1 (1) and lead 9B RC1-REV terminal 51 (2).
2. Does multimeter read 0 ohms?

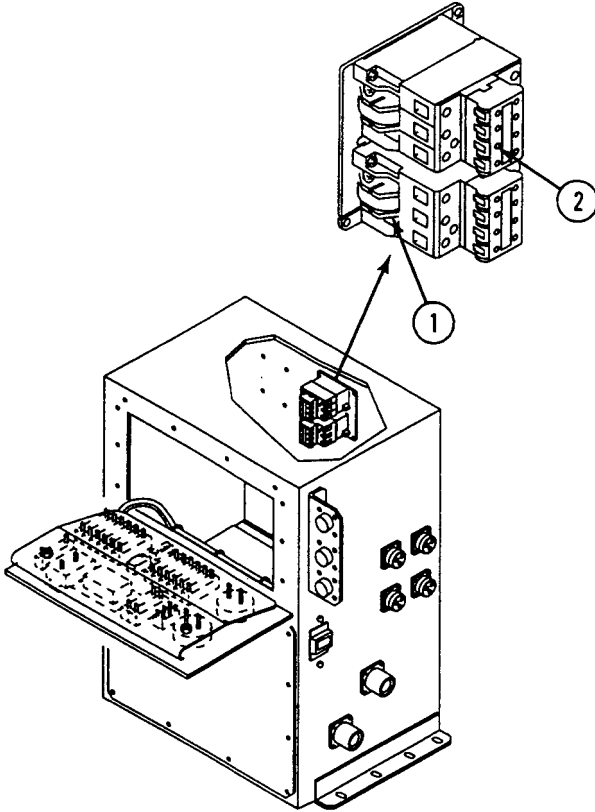

YES
↓

NO →

br17YN

1. Replace K4 relay (WP 0093 00).
2. Verify no faults found.

br18Y

NOTE

Use wiring diagram page 0008 00-14.

1. Measure resistance between reversing contactor RC1-FWD terminal 51 (1) and terminal 52 (2).
2. Does multimeter read 0 ohms?

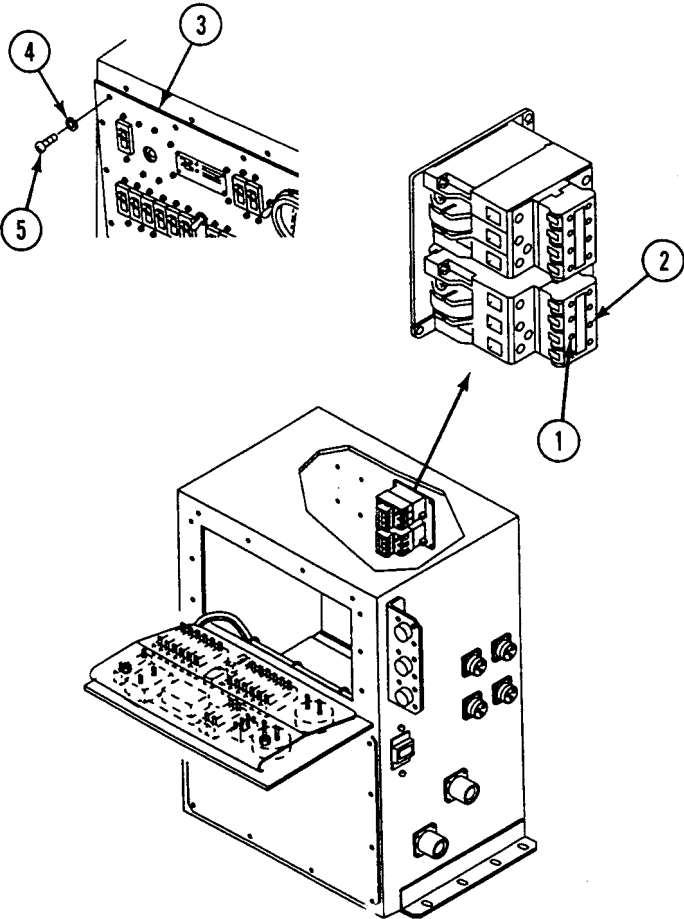

NO

br18YN

1. Replace reversing contactor RC1 (WP 0093 00).
2. Raise faceplate (3) and secure with ten new lockwashers (4) and screws (5).
3. Verify no faults found

YES

br19Y

1. Raise faceplate (3) and secure with ten new lockwashers (4) and screws (5).
2. Verify no faults found.

NO DC OUTPUT FROM DC POWER SUPPLY (M1068A3 ONLY)

0009 00

INITIAL SETUP:

Maintenance Level

Direct Support

Tools and Special Tools

General Mechanic's Tool Kit (WP 0120 00, Item 62)
 Digital Multimeter (WP 0120 00, Item 38)
 Special Purpose Power Cable
 (WP 0121 00, Figure 0121 00-3)

Personnel Required

Power-Generation Equipment Repairer 52D10
 Helper (H)

References

See your -10
 See your -20
 TM 11-7010-256-12&P
 See M1068A3 wiring diagram (see your -20)

Equipment Condition

Power control enclosure removed (see your -20)
 Power control enclosure faceplate lowered and power
 supply cover removed (see your -20)
 Unit level troubleshooting completed (see your -20)

WARNING



HIGH VOLTAGE is used in operation of this equipment.

DEATH ON CONTACT may result if personnel fail to observe safety precautions.

NEVER work on equipment unless at least one other person familiar with operation and hazards of equipment is nearby. That person should also be familiar with giving first aid. When an operator helps a mechanic, that operator must be warned about dangerous areas.

SHUT OFF POWER supply to equipment before beginning work. Make sure all external power is **OFF/disconnected**.

BE CAREFUL not to touch high-voltage connections when installing or operating this equipment.

T

1. Remove jumper cable (1) from terminal J1 (2) on power supply PS2 (3) and terminal J1 (4) on power supply PS1 (5).
2. Measure resistance between pins 9 (6) of jumper cable (1).
3. Does multimeter read 0 ohms?

NO

brTN

1. Replace jumper cable (WP 0090 00).
2. Verify no faults found.

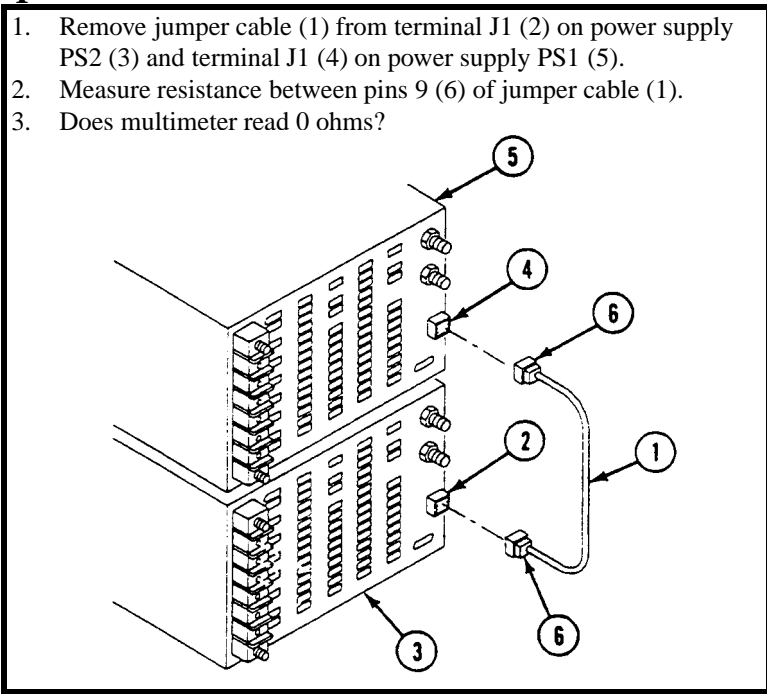

YES

brY

1. Connect Special Purpose Power Cable (1) to external AC power and to J24 (2) on Power Control Enclosure (3).
2. Remove circuit 31D (4) and circuit 32D (5) from power supply PS2 (6) and power supply PS1 (7).
3. Apply external AC power and set AC MAIN and DC POWER SUPPLY switches to ON (TM 11-7010-256-12&P).
4. Measure voltage between OUTPUT (+) terminal (8) and OUTPUT (-) terminal (9) on power supply PS1 (7).
5. Does multimeter read 26.4 volts DC or more?

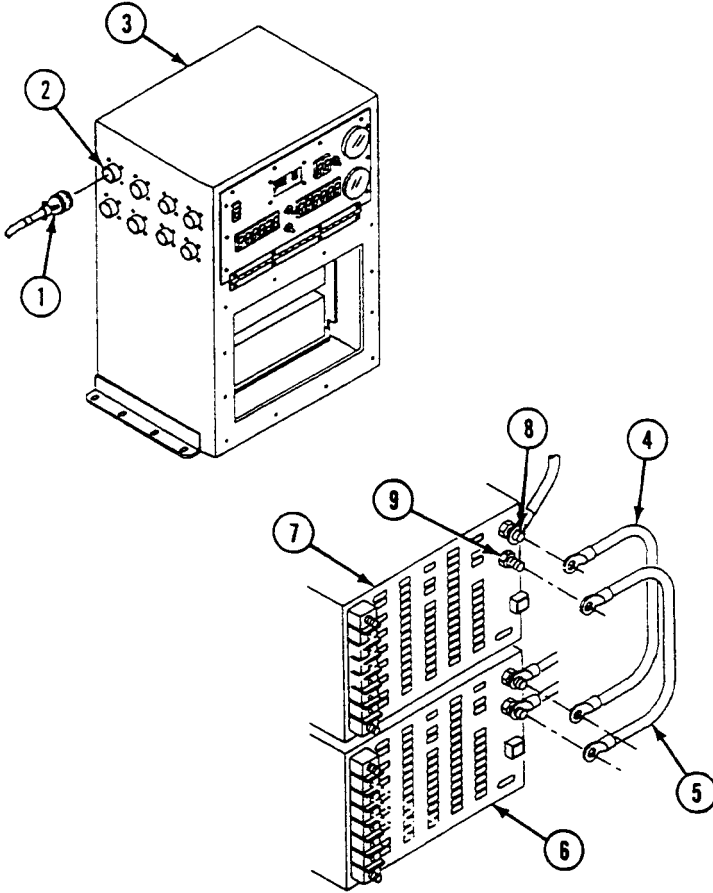

NO

brYN

1. Replace power supply PS1 (WP 0090 00).
2. Verify no faults found.

YES

br2Y

1. Measure voltage between OUTPUT (+) terminal (1) and OUTPUT (-) terminal (2) on power supply PS2 (3).
2. Does multimeter read 26.4 volts DC or more?

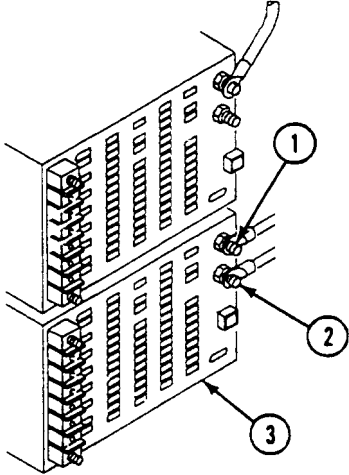

NO

br2YN

1. Replace power supply PS2 (WP 0090 00).
2. Verify no faults found.

YES

br3Y

1. Measure resistance between terminal ends of circuit 31D (1) and circuit 32D (2).
2. Does multimeter read 0 ohms for each measurement?

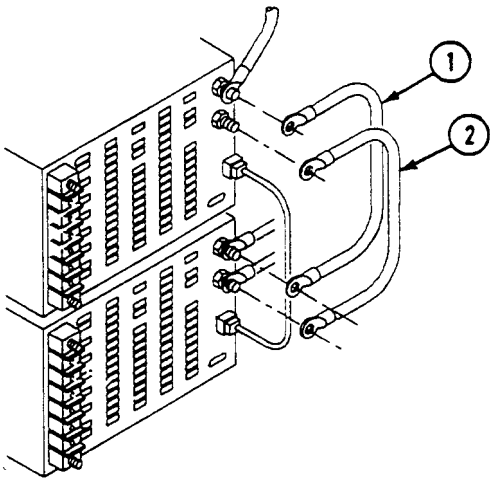

NO

br3YN

1. Replace circuit 31D and/or circuit 32D (WP 0090 00).
2. Verify no faults found.

YES

br4Y

1. Remove all power from SICPS system (see your -10) and (TM 11-7010-256-12&P).
2. Install all circuits on power supplies PS1 (1) and PS2 (2).
3. Measure resistance between PS1 (+) OUTPUT terminal (3) and DC bus bar at terminal 1 (4) of circuit breaker CB15 (5).
4. Does multimeter read 0 ohms?

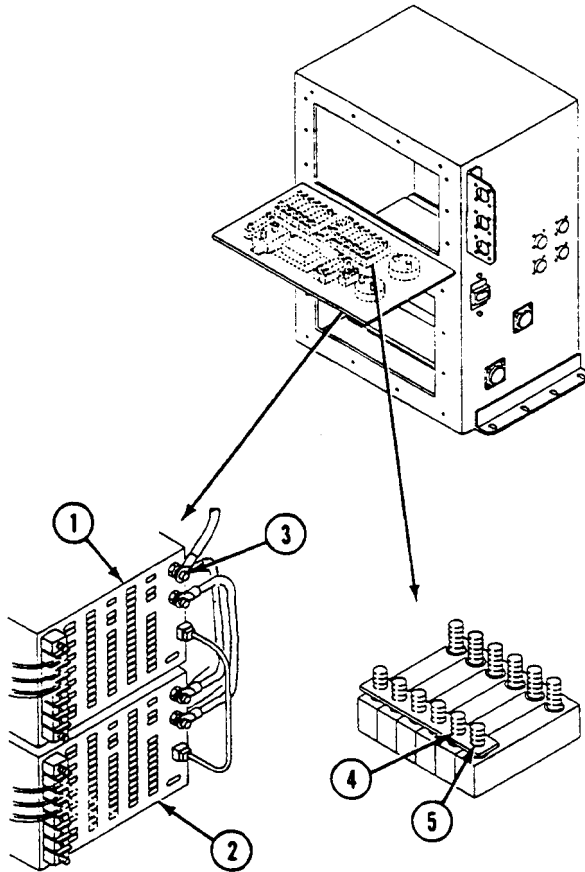

YES



NO

br4YN

1. Replace lead 31E (WP 0090 00) and (see your -20).
2. Verify no faults found.

br5Y

1. Measure resistance between power supply PS2 (+) OUTPUT terminal (1) and pin A2 (2) of relay K6 (3).
2. Does multimeter read 0 ohms?

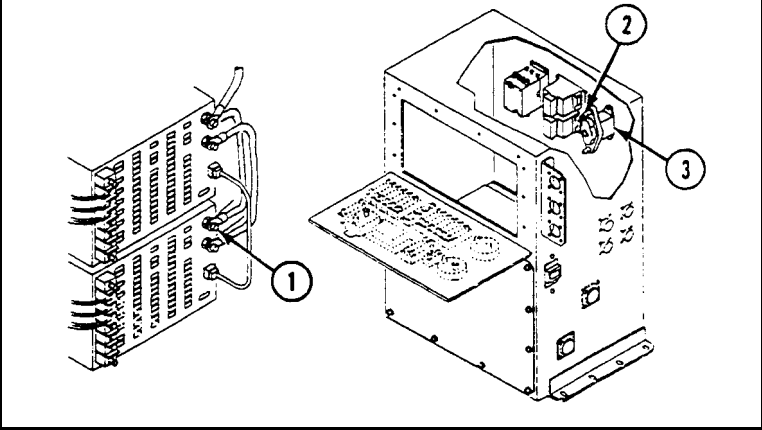

NO

br5YN

1. Replace lead 31C (WP 0090 00) and (WP 0093 00).
2. Verify no faults found.

YES

br6Y

1. Remove cable W4 plug P1 (1) from Power Control Enclosure jack J25 (2).
2. Measure resistance between power supply PS2 (-) OUTPUT terminal (3) and jack J25 (2) outer sleeve.
3. Does multimeter read 0 ohms?

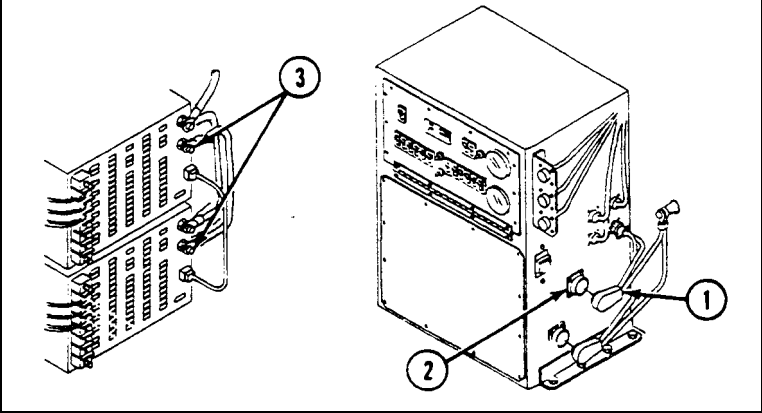

NO

br6YN

1. Replace lead 32E (WP 0090 00) and (WP 0092 00).
2. Install cable W4 plug P1 (1) on Power Control Enclosure jack J25 (2).
3. Verify no faults found.

YES

br7Y

- | |
|---|
| <ol style="list-style-type: none">1. Install cable W4 plug P1 (1) on Power Control Enclosure jack J25 (2).2. Verify no faults found. |
|---|

PATCH PANEL BOX A10 INOPERATIVE (M1068A3 ONLY)

0010 00

INITIAL SETUP:

Maintenance Level

Direct Support

Tools and Special Tools

Electrical Tool Kit (WP 0120 00, Item 60)
Digital Multimeter (WP 0120 00, Item 38)

Personnel Required

Radio Repairer 29E10
Helper (H)

References

See your -10
See your -20
See M1068A3 wiring diagram (see your -20)

Equipment Condition

Engine stopped (see your -10)
Carrier blocked (see your -20)

WARNING



HIGH VOLTAGE is used in the operation of this equipment.

DEATH ON CONTACT may result if personnel fail to observe safety precautions.

NEVER work on equipment unless at least one other person familiar with the operation and hazards of the equipment is nearby. That person should also be familiar with giving first aid. When an operator helps a mechanic, that operator must be warned about dangerous areas.

SHUT OFF POWER supply to equipment before beginning work. Make sure all external power is off/disconnected.

BE CAREFUL not to contact high voltage connections when installing or operating this equipment.

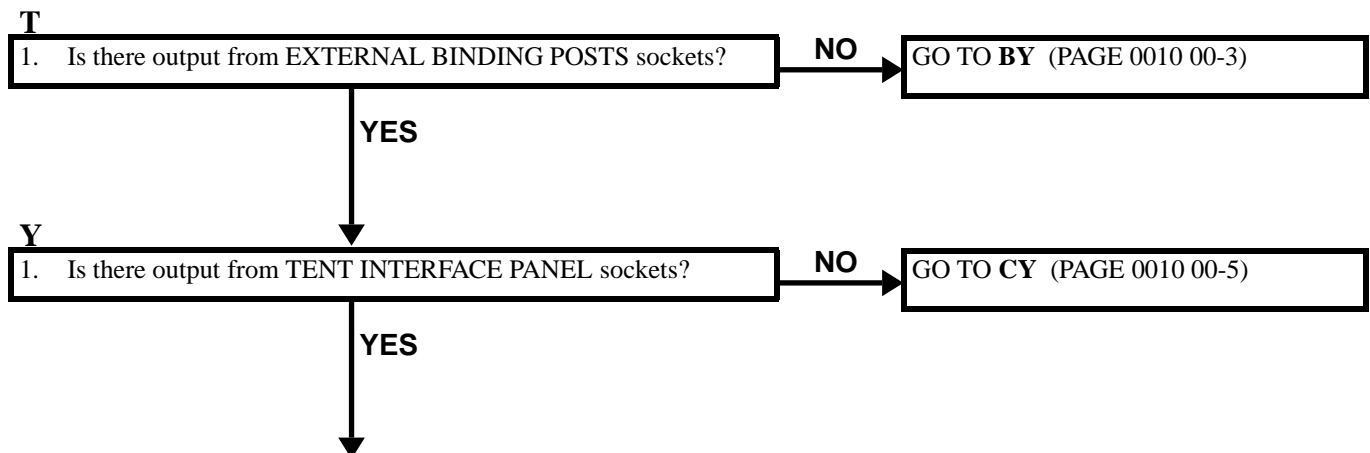

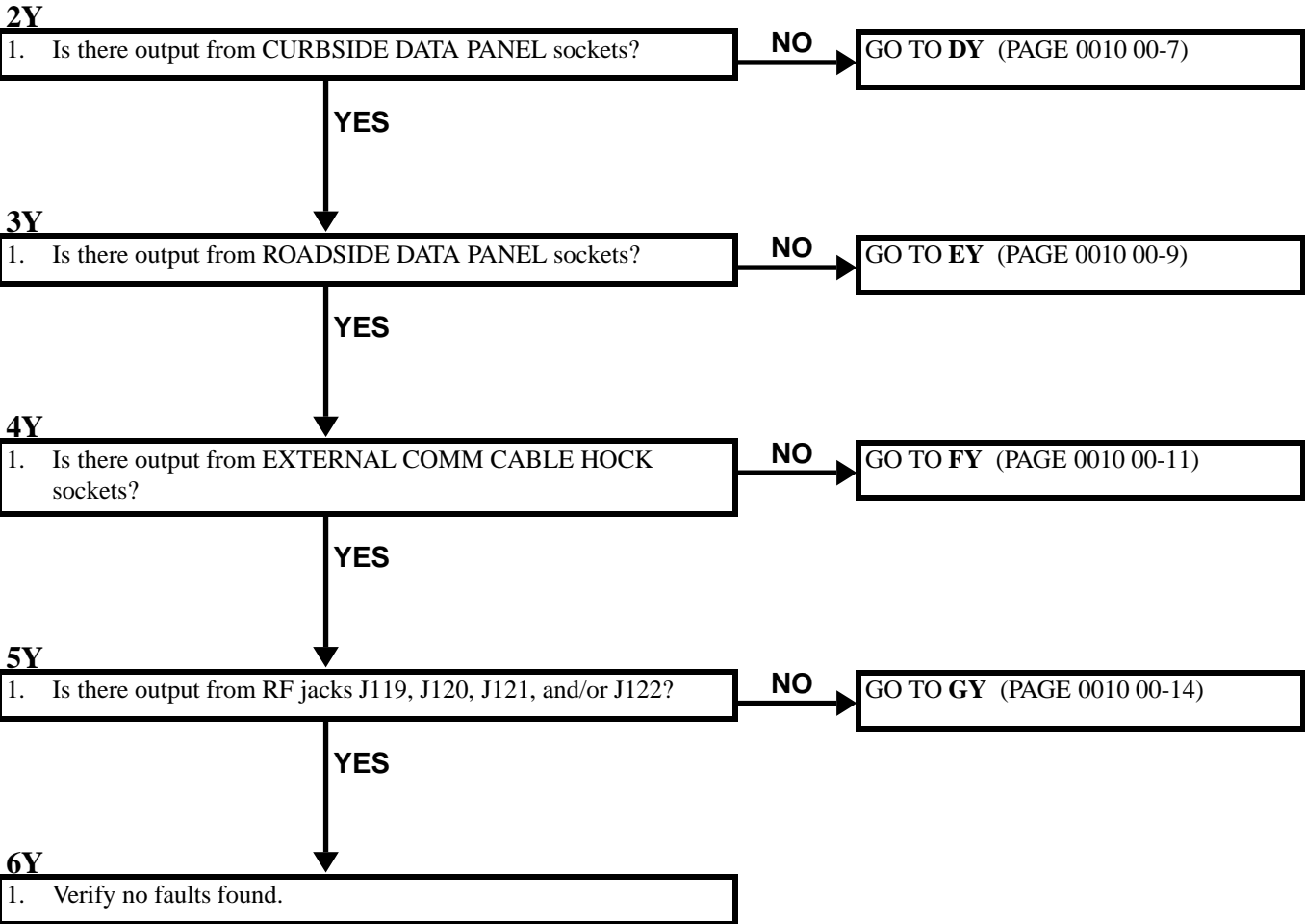

BY

NOTE

Use patch cable with multimeter. See WP 0012 00 for instructions.

1. Remove cable W115 plug P106 (1) from Patch Panel Box A10 jack J136 (2).
2. Measure resistance between 8 pairs of telephone jacks marked EXTERNAL COMM BINDING POSTS and sockets on jack J136 (2) as follows:

Jack 1 (Bot) to socket A	Jack 1 (Top) to socket B
Jack 2 (Bot) to socket C	Jack 2 (Top) to socket D
Jack 3 (Bot) to socket E	Jack 3 (Top) to socket F
Jack 4 (Bot) to socket G	Jack 4 (Top) to socket H
Jack 5 (Bot) to socket J	Jack 5 (Top) to socket K
Jack 6 (Bot) to socket L	Jack 6 (Top) to socket M
Jack 7 (Bot) to socket N	Jack 7 (Top) to socket P
Jack 8 (Bot) to socket R	Jack 8 (Top) to socket S
3. Does multimeter read 0 ohms for each measurement?

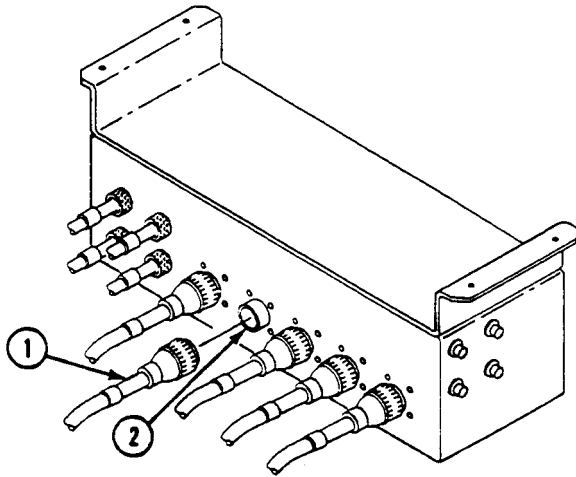

YES

NO

BYN

1. Repair Patch Panel Box A10 (WP 0099 00).
2. Verify no faults found.

B2Y

1. Measure resistance between pins on cable W115 plug P106 (1) and posts on External Communication Box A11 (2) front panel as follows:

- | | |
|-----------------------|-----------------------|
| Post 1 (Blk) to pin A | Post 1 (Red) to pin B |
| Post 2 (Blk) to pin C | Post 2 (Red) to pin D |
| Post 3 (Blk) to pin E | Post 3 (Red) to pin F |
| Post 4 (Blk) to pin G | Post 4 (Red) to pin H |
| Post 5 (Blk) to pin J | Post 5 (Red) to pin K |
| Post 6 (Blk) to pin L | Post 6 (Red) to pin M |
| Post 7 (Blk) to pin N | Post 7 (Red) to pin P |
| Post 8 (Blk) to pin R | Post 8 (Red) to pin S |

2. Does multimeter read 0 ohms for each measurement?

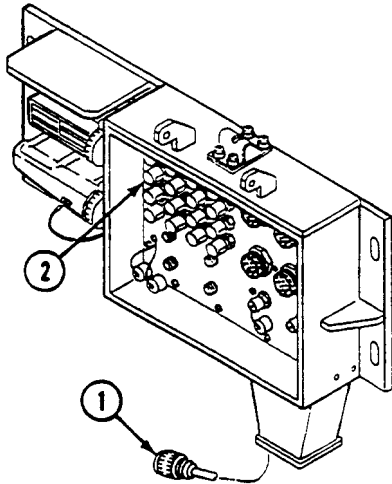

NO

B2YN

1. Replace cable W115 (WP 0107 00).
2. Verify no faults found.

YES

B3Y

1. Verify no faults found.

CY

NOTE

Use patch cable with multimeter. See WP 0012 00 for instructions and wiring diagram.

1. Remove cable W32 plug P107 (1) from Patch Panel Box A10 jack J138 (2).
2. Measure resistance between 12 pairs of telephone jacks (3) marked TENT INTERFACE PANEL and sockets on jack J138 (2) as follows:

Jack 1 (Bot) to socket A	Jack 1 (Top) to socket B
Jack 2 (Bot) to socket C	Jack 2 (Top) to socket D
Jack 3 (Bot) to socket E	Jack 3 (Top) to socket F
Jack 4 (Bot) to socket G	Jack 4 (Top) to socket H
Jack 5 (Bot) to socket J	Jack 5 (Top) to socket K
Jack 6 (Bot) to socket L	Jack 6 (Top) to socket M
Jack 7 (Bot) to socket N	Jack 7 (Top) to socket P
Jack 8 (Bot) to socket R	Jack 8 (Top) to socket S
Jack 9 (Bot) to socket T	Jack 9 (Top) to socket U
Jack 10 (Bot) to socket V	Jack 10 (Top) to socket W
Jack 11 (Bot) to socket X	Jack 11 (Top) to socket Y
Jack 12 (Bot) to socket Z	Jack 12 (Top) to socket a
3. Does multimeter read 0 ohms for each measurement?

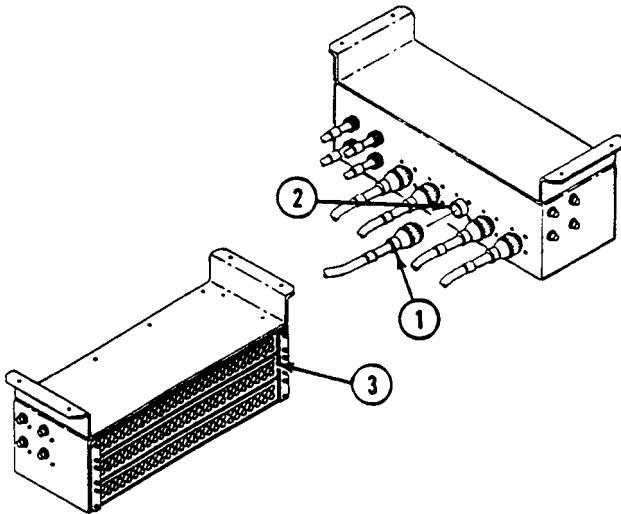

YES

NO

CYN

1. Repair Patch Panel Box A10 (WP 0099 00).
2. Verify no faults found.

C2Y

1. Remove cable W32 plug P7 (1) from Tent Interface Panel jack J8 (2).
2. Measure resistance between sockets on plug P7 (1) and pins on plug P107 (3) of cable W32 as follows:

Socket A to pin A	Socket B to pin B
Socket C to pin C	Socket D to pin D
Socket E to pin E	Socket F to pin F
Socket G to pin G	Socket H to pin H
Socket J to pin J	Socket K to pin K
Socket L to pin L	Socket M to pin M
Socket N to pin N	Socket P to pin P
Socket R to pin R	Socket S to pin S
Socket T to pin T	Socket U to pin U
Socket V to pin V	Socket W to pin W
Socket X to pin X	Socket Y to pin Y
Socket Z to pin Z	Socket a to pin a
3. Does multimeter read 0 ohms for each measurement?

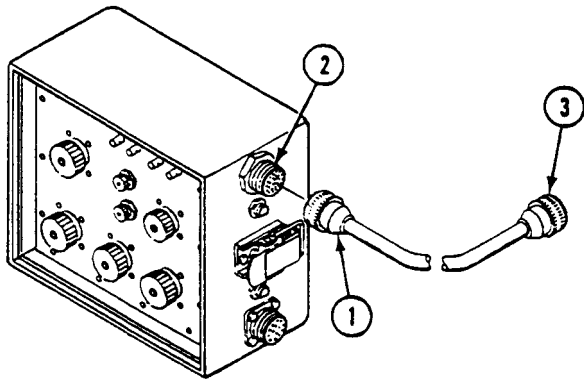

NO

C2YN

1. Replace cable W32 (see your -20).
2. Verify no faults found.

YES

C3Y

1. Verify no faults found.

DY

NOTE

Use patch cable with multimeter. See WP 0012 00 for instructions and wiring diagram.

1. Remove cable W124 plug P109 (1) from Patch Panel Box A10 jack J140 (2).
2. Measure resistance between 12 pairs of telephone jacks (3) marked CURBSIDE DATA PANEL and sockets on jack J140 (2) as follows:

Jack 1 (Bot) to socket A	Jack 1 (Top) to socket B
Jack 2 (Bot) to socket C	Jack 2 (Top) to socket D
Jack 3 (Bot) to socket E	Jack 3 (Top) to socket F
Jack 4 (Bot) to socket G	Jack 4 (Top) to socket H
Jack 5 (Bot) to socket J	Jack 5 (Top) to socket K
Jack 6 (Bot) to socket L	Jack 6 (Top) to socket M
Jack 7 (Bot) to socket N	Jack 7 (Top) to socket P
Jack 8 (Bot) to socket R	Jack 8 (Top) to socket S
Jack 9 (Bot) to socket T	Jack 9 (Top) to socket U
Jack 10 (Bot) to socket V	Jack 10 (Top) to socket W
Jack 11 (Bot) to socket X	Jack 11 (Top) to socket Y
Jack 12 (Bot) to socket Z	Jack 12 (Top) to socket a
3. Does multimeter read 0 ohms for each measurement?

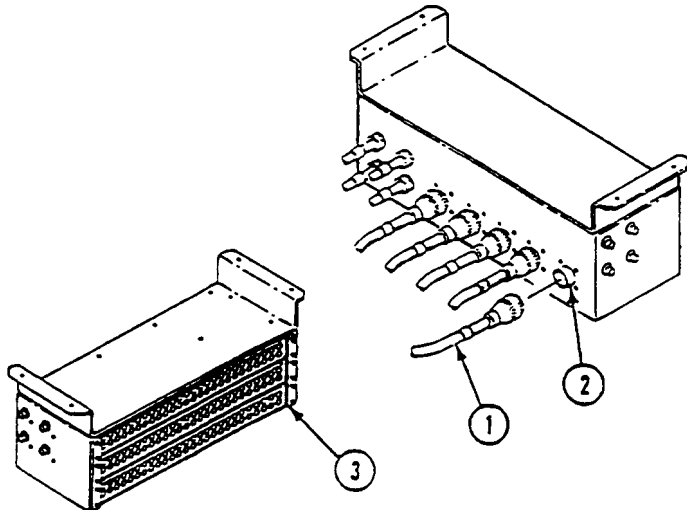

YES

DYN

1. Repair Patch Panel Box A10 (WP 0099 00).
2. Verify no faults found.

D2Y

1. Remove cable W124 plug P1 (1) from Curbside Data Panel jack J3 (2).
2. Measure resistance between sockets on plug P1 (1) and pins on plug P109 (3) of cable W124 as follows:

Socket A to pin A	Socket B to pin B
Socket C to pin C	Socket D to pin D
Socket E to pin E	Socket F to pin F
Socket G to pin G	Socket H to pin H
Socket J to pin J	Socket K to pin K
Socket L to pin L	Socket M to pin M
Socket N to pin N	Socket P to pin P
Socket R to pin R	Socket S to pin S
Socket T to pin T	Socket U to pin U
Socket V to pin V	Socket W to pin W
Socket X to pin X	Socket Y to pin Y
Socket Z to pin Z	Socket a to pin a
3. Does multimeter read 0 ohms for each measurement?

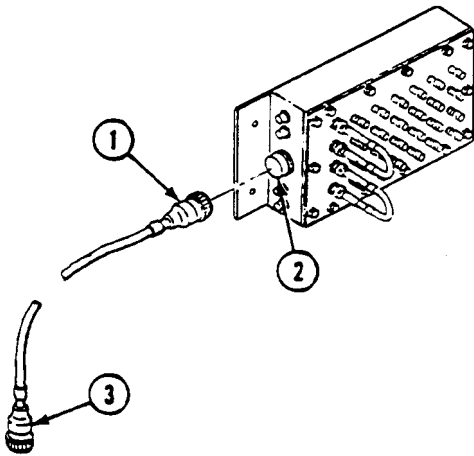

NO

D2YN

1. Replace cable W124 (see your -20).
2. Verify no faults found.

YES

D3Y

1. Verify no faults found.

EY

NOTE

Use patch cable with multimeter. See WP 0012 00 for instructions and wiring diagram.

1. Remove cable W126 plug P108 (1) from Patch Panel Box A10 jack J139 (2).
2. Measure resistance between 12 pairs of telephone jacks (3) marked ROADSIDE DATA PANEL and sockets on jack J139 (2) as follows:

Jack 1 (Bot) to socket A	Jack 1 (Top) to socket B
Jack 2 (Bot) to socket C	Jack 2 (Top) to socket D
Jack 3 (Bot) to socket E	Jack 3 (Top) to socket F
Jack 4 (Bot) to socket G	Jack 4 (Top) to socket H
Jack 5 (Bot) to socket J	Jack 5 (Top) to socket K
Jack 6 (Bot) to socket L	Jack 6 (Top) to socket M
Jack 7 (Bot) to socket N	Jack 7 (Top) to socket P
Jack 8 (Bot) to socket R	Jack 8 (Top) to socket S
Jack 9 (Bot) to socket T	Jack 9 (Top) to socket U
Jack 10 (Bot) to socket V	Jack 10 (Top) to socket W
Jack 11 (Bot) to socket X	Jack 11 (Top) to socket Y
Jack 12 (Bot) to socket Z	Jack 12 (Top) to socket a
3. Does multimeter read 0 ohms for each measurement?

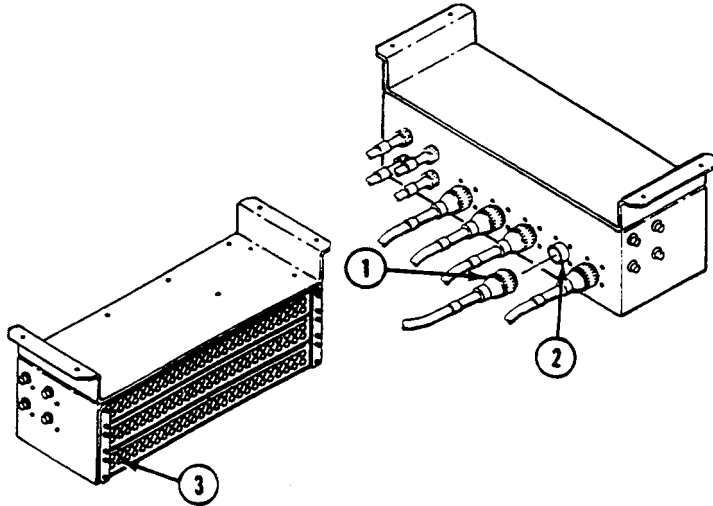

YES

NO

EYN

1. Repair Patch Panel Box A10 (WP 0099 00).
2. Verify no faults found.

E2Y

1. Remove cable W126 plug P1 (1) from Roadside Data Panel jack J3 (2).
2. Measure resistance between sockets on P1 (1) and pins on P108 (3) of cable W126 as follows:

Socket A to pin A	Socket B to pin B
Socket C to pin C	Socket D to pin D
Socket E to pin E	Socket F to pin F
Socket G to pin G	Socket H to pin H
Socket J to pin J	Socket K to pin K
Socket L to pin L	Socket M to pin M
Socket N to pin N	Socket P to pin P
Socket R to pin R	Socket S to pin S
Socket T to pin T	Socket U to pin U
Socket V to pin V	Socket W to pin W
Socket X to pin X	Socket Y to pin Y
Socket Z to pin Z	Socket a to pin a
3. Does multimeter read 0 ohms for each measurement?

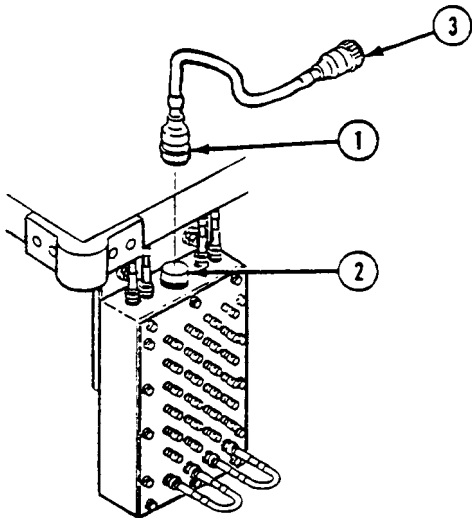

NO

E2YN

1. Replace cable W126 (see your -20).
2. Verify no faults found.

YES

E3Y

1. Verify no faults found.

FY

NOTE

Use patch cable with multimeter. See WP 0012 00 for instructions and wiring diagram.

1. Remove cable W118 plug P105 (1) from Patch Panel Box A10 jack J135 (2).
2. Measure resistance between 26 pairs of telephone jacks (J1 Bot or Top to J26 Bot or Top) (3) marked EXTERNAL COMM CABLE HOCK and sockets (s1–s52) of jack J135 (2) as follows:

J1 (Bot) to s1	J1 (Top) to s2	J2 (Bot) to s3
J2 (Top) to s4	J3 (Bot) to s5	J3 (Top) to s6
J4 (Bot) to s7	J4 (Top) to s8	J5 (Bot) to s9
J5 (Top) to s10	J6 (Bot) to s11	J6 (Top) to s12
J7 (Bot) to s13	J7 (Top) to s14	J8 (Bot) to s15
J8 (Top) to s16	J9 (Bot) to s17	J9 (Top) to s18
J10 (Bot) to s19	J10 (Top) to s20	J11 (Bot) to s21
J11 (Top) to s22	J12 (Bot) to s23	J12 (Top) to s24
J13 (Bot) to s25	J13 (Top) to s26	J14 (Bot) to s27
J14 (Top) to s28	J15 (Bot) to s29	J15 (Top) to s30
J16 (Bot) to s31	J16 (Top) to s32	J17 (Bot) to s33
J17 (Top) to s34	J18 (Bot) to s35	J18 (Top) to s36
J19 (Bot) to s37	J19 (Top) to s38	J20 (Bot) to s39
J20 (Top) to s40	J21 (Bot) to s41	J21 (Top) to s42
J22 (Bot) to s43	J22 (Top) to s44	J23 (Bot) to s45
J23 (Top) to s46	J24 (Bot) to s47	J24 (Top) to s48
J25 (Bot) to s49	J25 (Top) to s50	J26 (Bot) to s51
J26 (Top) to s52		
3. Does multimeter read 0 ohms for each measurement?

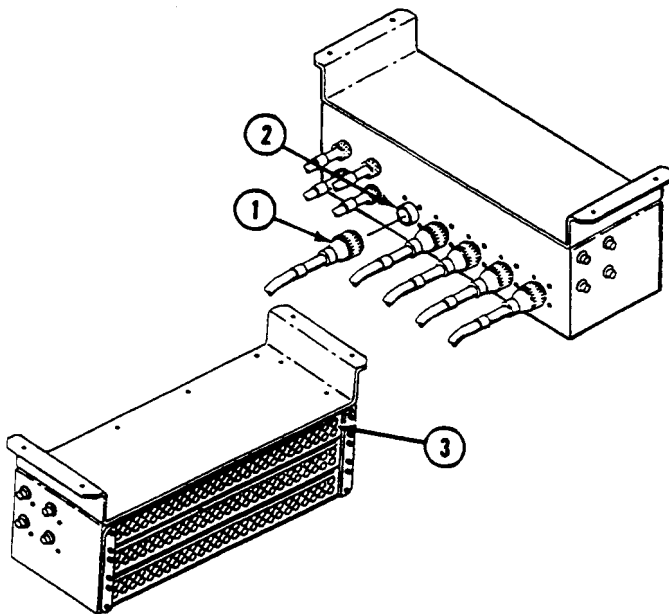

NO

FYN

1. Repair Patch Panel Box A10 (WP 0099 00).
2. Verify no faults found.

YES

F2Y

1. Measure resistance between pins (P1 thru P52) on plug P105 (1) of cable W118 and pins (p1 A or B thru p26 A or B) on connector J101 (2) of External Communication Box A11 (3) front panel as follows:

- | | | |
|-------------|-------------|-------------|
| P1 to p1A | P2 to p1B | P3 to p2A |
| P4 to p2B | P5 to p3A | P6 to p3B |
| P7 to p4A | P8 to p4B | P9 to p5A |
| P10 to p5B | P11 to p6A | P12 to p6B |
| P13 to p7A | P14 to p7B | P15 to p8A |
| P16 to p8B | P17 to p9A | P18 to p9B |
| P19 to p10A | P20 to p10B | P21 to p11A |
| P22 to p11B | P23 to p12A | P24 to p12B |
| P25 to p13A | P26 to p13B | P27 to p14A |
| P28 to p14B | P29 to p15A | P30 to p15B |
| P31 to p16A | P32 to p16B | P33 to p17A |
| P34 to p17B | P35 to p18A | P36 to p18B |
| P37 to p19A | P38 to p19B | P39 to p20A |
| P40 to p20B | P41 to p21A | P42 to p21B |
| P43 to p22A | P44 to p22B | P45 to p23A |
| P46 to p23B | P47 to p24A | P48 to p24B |
| P49 to p25A | P50 to p25B | P51 to p26A |
| P52 to p26B | | |

2. Does multimeter read 0 ohms for each measurement?

NO

F2YN

1. Replace cable W118 (WP 0108 00).
2. Verify no faults found.

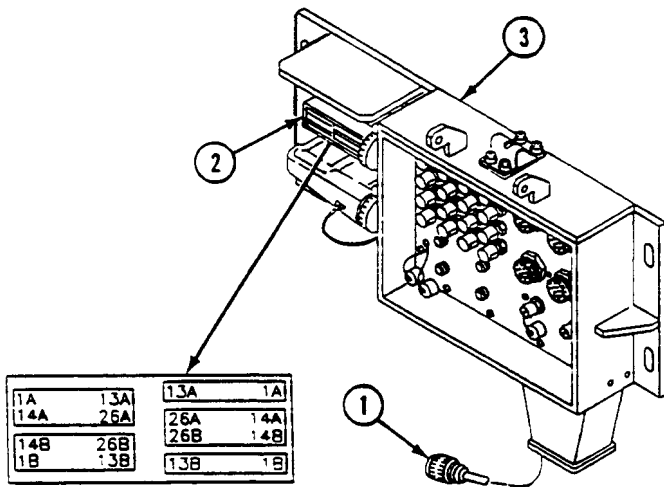

YES

F3Y

1. Measure resistance between pins (P1 A or B thru P26 A or B) on connector J101 (1) and connector J102 (2) of External Communication Box A11 (3) front panel as follows:

P1A to p1A	P1B to p1B	P2A to p2A
P2B to p2B	P3A to p3A	P3B to p3B
P4A to p4A	P4B to p4B	P5A to p5A
P5B to p5B	P6A to p6A	P6B to p6B
P7A to p7A	P7B to p7B	P8A to p8A
P8B to p8B	P9A to p9A	P9B to p9B
P10A to p10A	P10B to p10B	P11A to p11A
P11B to p11B	P12A to p12A	P12B to p12B
P13A to p13A	P13B to p13B	P14A to p14A
P14B to p14B	P15A to p15A	P15B to p15B
P16A to p16A	P16B to p16B	P17A to p17A
P17B to p17B	P18A to p18A	P18B to p18B
P19A to p19A	P19B to p19B	P20A to p20A
P20B to p20B	P21A to p21A	P21B to p21B
P22A to p22A	P22B to p22B	P23A to p23A
P23B to p23B	P24A to p24A	P24B to p24B
P25A to p25A	P25B to p25B	P26A to p26A
P26B to p26B		
2. Does multimeter read 0 ohms for each measurement?

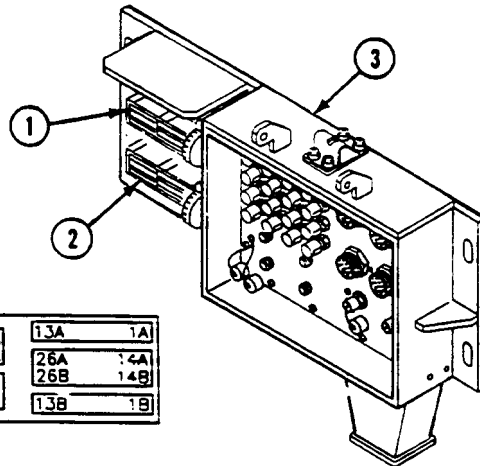

NO

F3YN

1. Replace cable W117 (WP 0108 00).
2. Verify no faults found.

YES

F4Y

1. Verify no faults found.

GY

1. Remove cable plugs from the Patch Panel Box A10 jacks as follows:

- Cable W111 plug P1 (1) from J125 (5)
- Cable W112 plug P1 (2) from J124 (8)
- Cable W113 plug P1 (3) from J123 (7)
- Cable W114 plug P1 (4) from J126 (6)

2. Measure resistance between pins of the following:

- J125 (5) to J119 (9)
- J126 (6) to J120 (10)
- J123 (7) to J121 (11)
- J124 (8) to J122 (12)

3. Does multimeter read 0 ohms for each measurement?

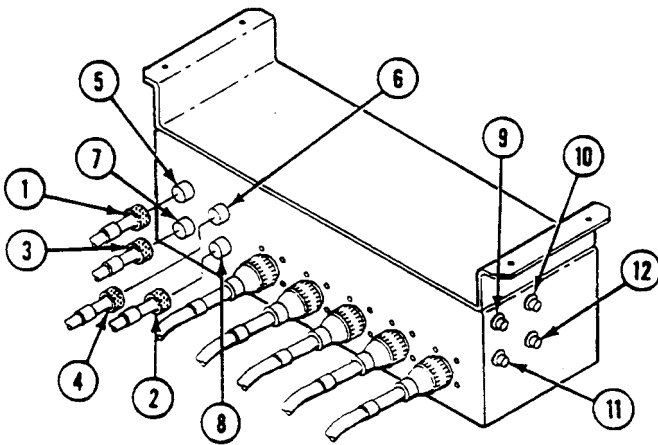

YES

NO

GYN

1. Repair Patch Panel Box A10 (WP 0099 00).
2. Verify no faults found.

G2Y

1. Measure resistance between cable plugs and pins on jacks of External Communication Box A11 as follows:
 - W111 plug P1 (1) and pin of jack J115 (5)
 - W112 plug P1 (2) and pin of jack J116 (6)
 - W113 plug P1 (3) and pin of jack J117 (7)
 - W114 plug P1 (4) and pin of jack J118 (8)
2. Does multimeter read 0 ohms for each measurement?

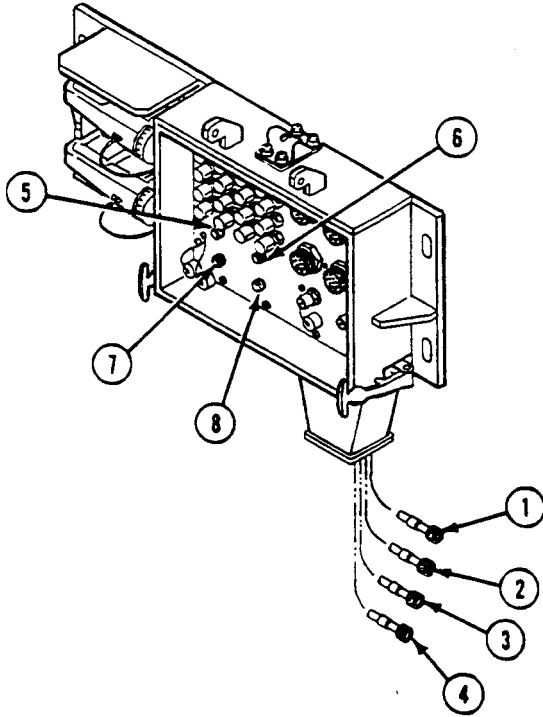

NO

G2YN

1. Replace cables W111, W112, W113, and/or W114 (WP 0106 00).
2. Verify no faults found.

YES

G3Y

1. Verify no faults found.

EXTERNAL COMMUNICATION BOX A11 INOPERATIVE (M1068A3 ONLY)

0011 00

INITIAL SETUP:

Maintenance Level

Direct Support

Tools and Special Tools

- Electrical Tool Kit (WP 0120 00, Item 60)
- Digital Multimeter (WP 0120 00, Item 38)

Personnel Required

- Radio Repairer 29E10
- Helper (H)

References

- See your -10
- See your -20
- See M1068A3 wiring diagram (see your -20)

Equipment Condition

- Engine stopped (see your -10)
- Carrier blocked (see your -10)

WARNING



HIGH VOLTAGE is used in the operation of this equipment.

DEATH ON CONTACT may result if personnel fail to observe safety precautions.

NEVER work on equipment unless at least one other person familiar with the operation and hazards of the equipment is nearby. That person should also be familiar with giving first aid. When an operator helps a mechanic, that operator must be warned about dangerous areas.

SHUT OFF POWER supply to equipment before beginning work. Make sure all external power is off/disconnected.

BE CAREFUL not to contact high-voltage connections when installing or operating this equipment.

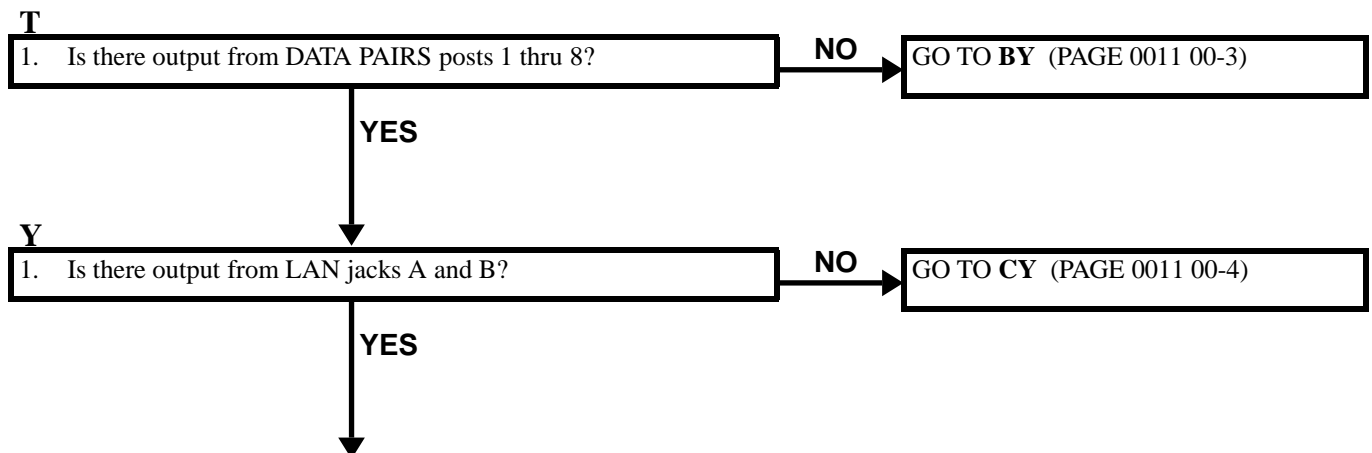

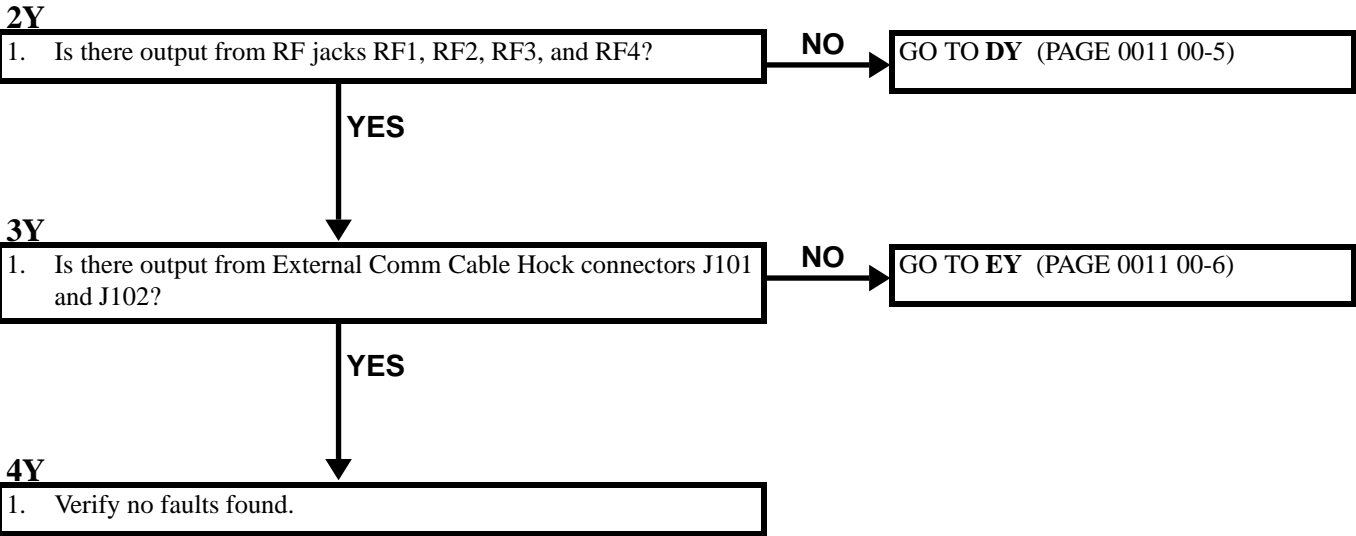

BY

1. Remove cable W115 plug P106 (1) from Patch Panel Box A10 jack J136 (2).
2. Measure resistance between pins of cable W115 plug P106 (1) and DATA PAIRS posts (3) on front panel of External Communication Box A11 (4) as follows:

Post 1 (Blk) to pin A	Post 1 (Red) to pin B
Post 2 (Blk) to pin C	Post 2 (Red) to pin D
Post 3 (Blk) to pin E	Post 3 (Red) to pin F
Post 4 (Blk) to pin G	Post 4 (Red) to pin H
Post 5 (Blk) to pin J	Post 5 (Red) to pin K
Post 6 (Blk) to pin L	Post 6 (Red) to pin M
Post 7 (Blk) to pin N	Post 7 (Red) to pin P
Post 8 (Blk) to pin R	Post 8 (Red) to pin S
3. Does multimeter read 0 ohms for each measurement?

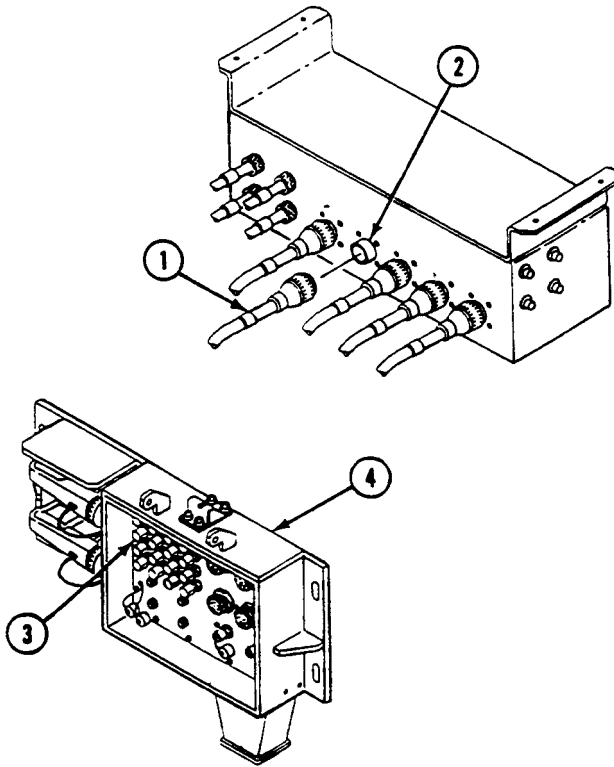

NO

BYN

1. Replace cable W115 (WP 0107 00).
2. Verify no faults found.

YES

B2Y

1. Verify no faults found.

CY

1. Remove cable W101 plug P1 (1) from jack J1 (2), and cable W102 plug P1 (3) from jack J4 (4) of Curbside Data Panel A12.
2. Measure resistance between pin on cable W101 plug P1 (1) and LAN jack A (5) on External Communication Box A11 (6) front panel. Repeat check for cable W102 plug P1 (3) and LAN jack B (7).
3. Does multimeter read 0 ohms for each measurement?

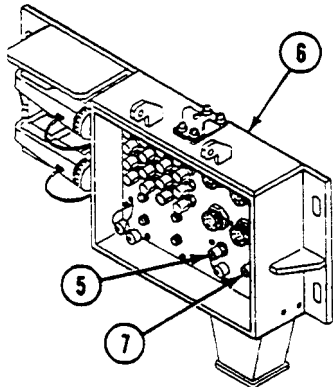
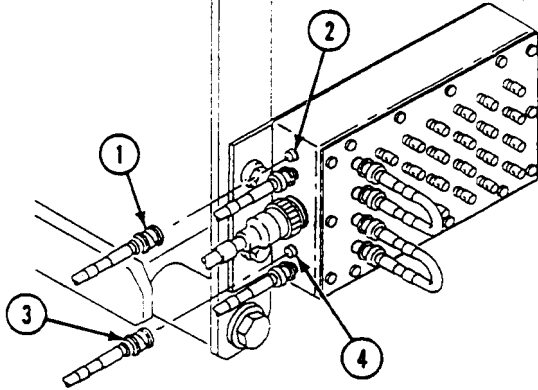

NO

CYN

1. Replace cable W101 and/or cable W102 (WP 0105 00).
2. Verify no faults found.

YES

C2Y

1. Verify no faults found.

DY

1. Remove cables from Patch Panel Box A10 as follows:
 - Cable W111 plug P1 (1) from J125 (5)
 - Cable W112 plug P1 (2) from J126 (6)
 - Cable W113 plug P1 (3) from J123 (7)
 - Cable W114 plug P1 (4) from J124 (8)
2. Measure resistance between pins of cables and RF jacks on External Communication Box A11 front panel as follows:
 - Cable W111 (1) to RF1 (9)
 - Cable W112 (2) to RF2 (10)
 - Cable W113 (3) to RF3 (11)
 - Cable W114 (4) to RF4 (12)
3. Does multimeter read 0 ohms for each measurement?

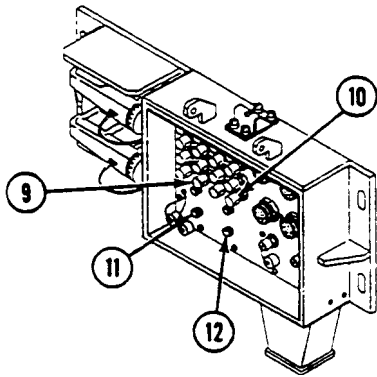
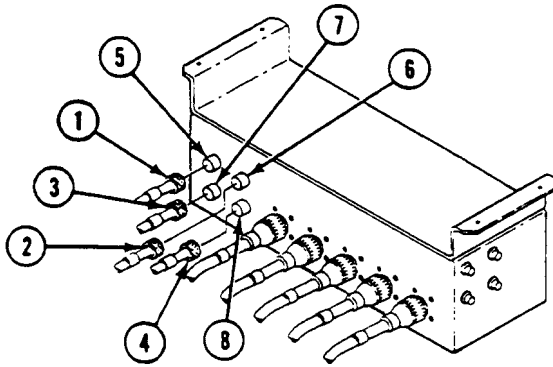

NO

DYN

1. Replace cables W111, W112, W113, and/or W114 (WP 0106 00).
2. Verify no faults found.

YES

D2Y

1. Verify no faults found.

EY

NOTE

Use connector diagram below.

1. Remove cable W118 plug P105 (1) from Patch Panel Box A10 jack J135 (2).
2. Measure resistance between pins (P1–P52) on cable W118 plug P105 (1) and pins (p1A or p1B thru p26A or p26B) on connector J101 (3) of External Communication Box A11 (4) as follows:

P1 to p1A	P2 to p1B	P3 to p2A
P4 to p2B	P5 to p3A	P6 to p3B
P7 to p4A	P8 to p4B	P9 to p5A
P10 to p5B	P11 to p6A	P12 to p6B
P13 to p7A	P14 to p7B	P15 to p8A
P16 to p8B	P17 to p9A	P18 to p9B
P19 to p10A	P20 to p10B	P21 to p11A
P22 to p11B	P23 to p12A	P24 to p12B
P25 to p13A	P26 to p13B	P27 to p14A
P28 to p14B	P29 to p15A	P30 to p15B
P31 to p16A	P32 to p16B	P33 to p17A
P34 to p17B	P35 to p18A	P36 to p18B
P37 to p19A	P38 to p19B	P39 to p20A
P40 to p20B	P41 to p21A	P42 to p21B
P43 to p22A	P44 to p22B	P45 to p23A
P46 to p23B	P47 to p24A	P48 to p24B
P49 to p25A	P50 to p25B	P51 to p26A
P52 to p26B		
3. Does multimeter read 0 ohms for each measurement?

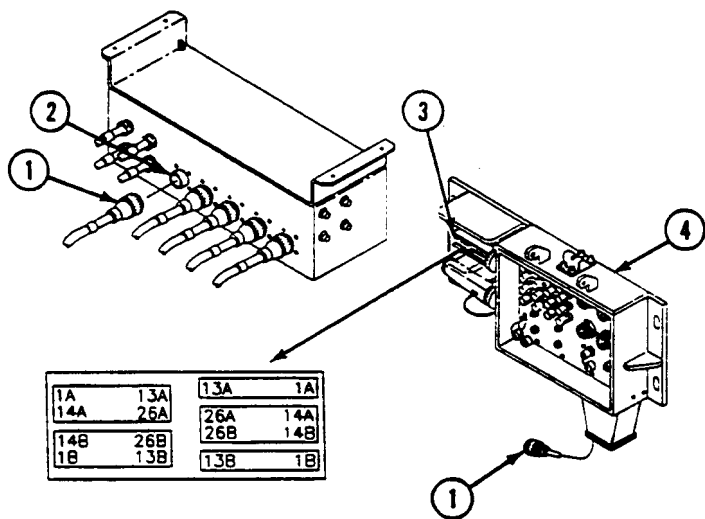

NO

EYN

1. Replace cable W118 (WP 0108 00).
2. Verify no faults found.

YES

E2Y

NOTE

Both connectors are identical. Use connector diagram below.

1. Measure resistance between pins (p1A or p1B thru p26A or p26B) on connector J101 (1) and pins (p1A or p1B thru p26A or p26B) on connector J102 (2) of External Communication Box A11 (3) front panel as follows:

P1A to p1A	P1B to p1B	P2A to p2A
P2B to p2B	P3A to p3A	P3B to p3B
P4A to p4A	P4B to p4B	P5A to p5A
P5B to p5B	P6A to p6A	P6B to p6B
P7A to p7A	P7B to p7B	P8A to p8A
P8B to p8B	P9A to p9A	P9B to p9B
P10A to p10A	P10B to p10B	P11A to p11A
P11B to p11B	P12A to p12A	P12B to p12B
P13A to p13A	P13B to p13B	P14A to p14A
P14B to p14B	P15A to p15A	P15B to p15B
P16A to p16A	P16B to p16B	P17A to p17A
P17B to p17B	P18A to p18A	P18B to p18B
P19A to p19A	P19B to p19B	P20A to p20A
P20B to p20B	P21A to p21A	P21B to p21B
P22A to p22A	P22B to p22B	P23A to p23A
P23B to p23B	P24A to p24A	P24B to p24B
P25A to p25A	P25B to p25B	P26A to p26A
P26B to p26B		

2. Does multimeter read 0 ohms for each measurement?

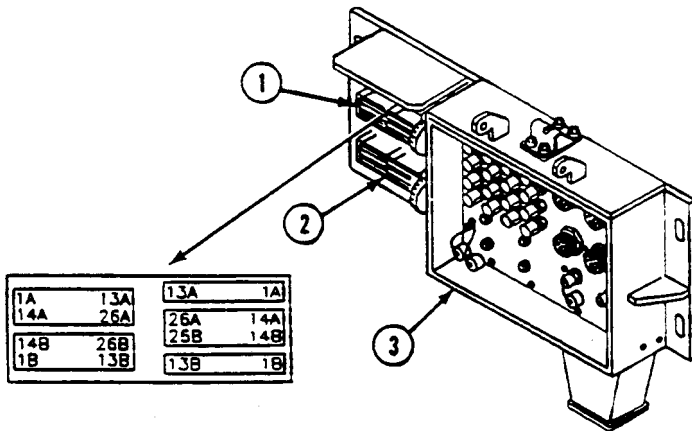

NO

E2YN

1. Replace cable W117 (WP 0108 00).
2. Verify no faults found.

YES

E3Y

1. Verify no faults found.

PATCH PANEL BOX A10

0012 00

INSTRUCTIONS FOR TESTING PATCH PANEL BOX A10

Insert patch cable (1) into telephone jack (2) to be checked on Patch Panel Box A10. Use a multimeter (3) to check resistance from listed jack socket (4) to other end of patch cable. Use plug test points (5) in accordance with wiring diagram.

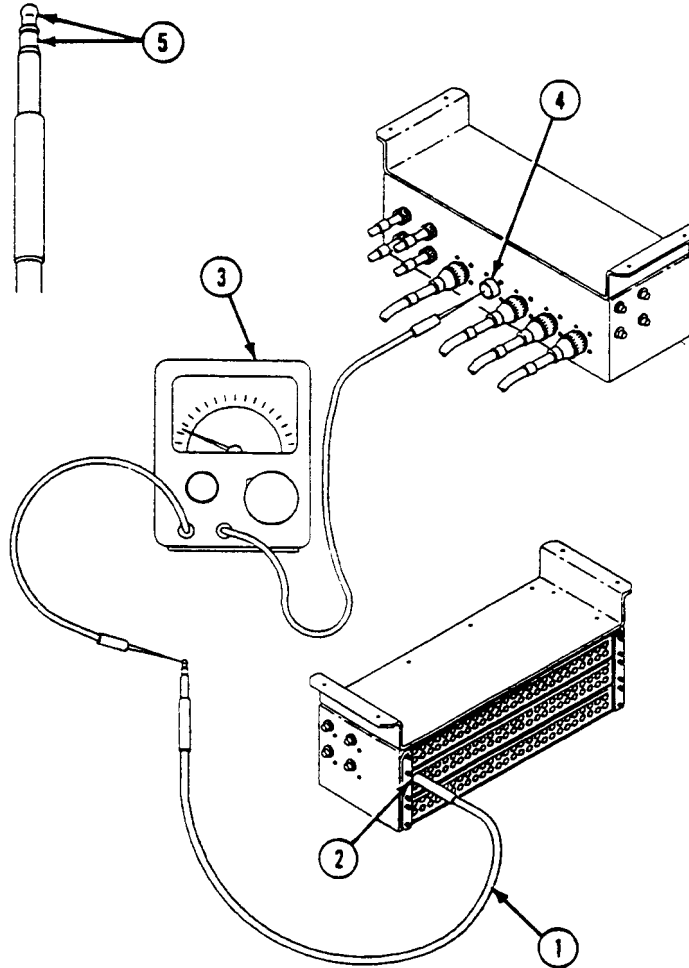

PATCH PANEL BOX A10 WIRING DIAGRAM (M1068A3 ONLY)

Use the wiring diagram below as an aid in performing troubleshooting procedures on the Patch Panel Box A10.

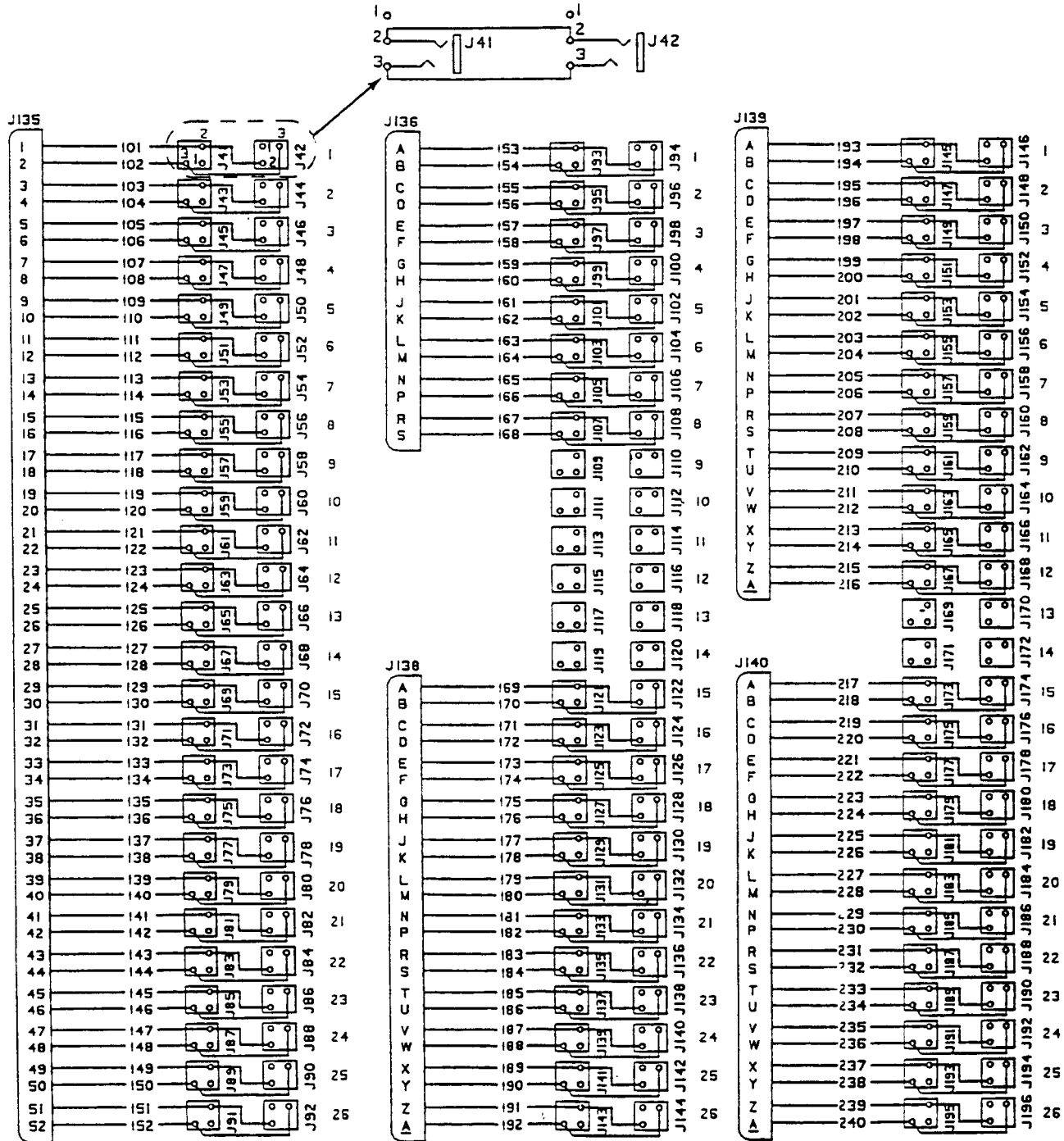

CHAPTER 3

GENERAL SUPPORT MAINTENANCE INSTRUCTIONS
FOR ENGINE

WORK PACKAGE INDEX

<u>Title</u>	<u>Sequence No.</u>
SERVICE UPON RECEIPT.....	0013 00
PREVENTIVE MAINTENANCE CHECKS AND SERVICES (PMCS), INCLUDING LUBRICATION INSTRUCTIONS.....	0014 00
REPLACE ENGINE.....	0015 00
REPLACE VARIABLE SPEED DRIVE ASSEMBLY ADAPTER.....	0016 00

SERVICE UPON RECEIPT

0013 00

THIS WORK PACKAGE COVERS:

Service upon receipt (Checking Unpacked Equipment).

INITIAL SETUP:

Maintenance Level

Direct Support

References

TM 9-2350-277-10

TM 9-2350-277-20

Tools and Special Tools

General Mechanic's Tool Kit (WP 0120 00, Item 62)

Equipment Condition

Engine stopped (see your -10)

Personnel Required

Track Vehicle Repairer 63H10

SERVICE UPON RECEIPT OF MATERIEL

Checking Unpacked Equipment

This section provides information on how to check and service your carrier when it is received. *Level B* and *A* deprocessing procedures are given in the following table. *Level B* deprocessing is performed when the carrier have been in storage for less than ninety (90) days. *Level A* deprocessing is performed, in addition to Level B deprocessing, when the carrier has been in storage for more than 90 days.

Table 1.

SERVICE UPON RECEIPT			
LOCATION	ITEM	ACTION	REMARKS
Hull	Driver's hatch	Remove welded nut/bolt from driver's hatch to gain vehicle entry.	
Engine	Engine air intake	(1) Remove air restrictor plug from air duct at air filter. (2) Connect filter host to air filter. (3) Remove warning tag.	
Engine	Fuel lines	(1) Connect fuel lines at quick disconnect. (2) Connect fuel supply tubing.	
Engine	Crankcase	Remove shipping tape from crankcase breather.	
Engine	Oil level gauge	Remove shipping tape from oil level gauge rod opening.	
Engine	Caps and plugs	Remove caps and plugs from all openings to engine that vent outside.	
Engine	Power plant access panels	Install power plant access panels.	
Hull	Carrier batteries	(1) Remove shipping tape from filler caps. (2) Add electrolyte and charge batteries. See TM 9-6140-200-14.	
Hull	Battery cables	Install cables on battery. See your -20.	

SERVICE UPON RECEIPT — Continued

0013 00

Hull	Personnel heater/feed line	(1) Remove shipping tape from heater external exhaust and intake elbows. (2) Remove shipping tape from end of disconnected fuel feed line. (3) Connect feed line to heater.	
Hull	Fuel system	Full fuel tank.	
Hull	Squad seats and backrests	Remove shipping paper and tape.	
Hull	Commander's seat and post	Install commander's seat and post on carrier. See your -20.	
Hull	Periscopes	(1) Remove plugs from periscope openings. (2) Remove periscopes from packages and install.	
Hull	Fire Extinguishers	Check for intact seals on handles.	
Hull	Drain plugs	Close hull drain plugs.	
Hull	Closure kit	Remove and store closure kit.	
Hull	Engine air inlet grille	Remove shipping tape and intake and exhaust grille cover from intake and exhaust grille.	
Hull	Armor mounting inserts and screw holes	Check for loose or missing plugs in inserts and setscrews in hull screw holes.	
LEVEL A			
For level A deprocessing, perform the following procedures in addition to all the procedures for Level B deprocessing.			
Power Plant Compartment	Engine	Change engine oil. See engine crankcase tag on filler neck and your PMCS.	
Power Plant Compartment	Transmission	Service transmission with operational lubricant. See transmission tag on filler neck and your PMCS.	
Hull	Final drives	Service final drives with operational lubricant. See your PMCS.	

Checking Unpacked Equipment

1. Perform all operator and unit PMCS. See your -10 and -20.
2. Inspect the equipment for damage incurred during shipment. If the equipment has been damaged, report the damage on Form SF 368 (Quality Deficiency Report).

END OF TASK

**PREVENTIVE MAINTENANCE CHECKS AND SERVICES (PMCS),
INCLUDING LUBRICATION INSTRUCTIONS**

0014 00

THIS WORK PACKAGE COVERS:

General Maintenance Instructions (page 0014 00–1).
Preventive Maintenance Checks and Services Including Lubrication Instructions (page 0014 00–14).

INITIAL SETUP:

<u>Maintenance Level</u>	<u>References</u>
Direct Support	See your -10
<u>Materials/Parts</u>	See your -20
Cleaning compound (WP 0122 00, Item 8)	TM 9-214
Crocus cloth (WP 0122 00, Item 11)	TM 9-235-277-24P
Detergent (WP 0122 00, Item 14)	TM 9-237
Wiping rag (WP 0122 00, Item 36)	TM 43-0139

GENERAL MAINTENANCE INSTRUCTIONS

SCOPE

This section contains safety warnings, guidelines, and general maintenance instructions. They should be followed when doing maintenance procedures authorized for direct and general support maintenance levels.

PREPARATION FOR MAINTENANCE

1. **PERSONNEL SAFETY.** Practice all shop safety procedures and read all warnings in this manual.
2. **PROPER EQUIPMENT.** Get tools and equipment before starting a maintenance task. See TM 9-2350-277-24P, and the maintenance tasks for tools, equipment, parts, and materials.
3. **WHAT TO DISCARD.** Parts to discard, such as lockwashers, locknuts, and gaskets are listed in the maintenance tasks. If the step does not say to discard a part, the part should be saved. It may be used later, or repaired.
4. **HANDLING TECHNIQUES.**
 - a. Avoid damage to parts during disassembly, cleaning, inspection, repair, and reassembly procedures. Nicks, scratches, and dents caused by careless handling could result in equipment failure.
 - b. Dirt can damage parts and cause malfunctions. Make sure all air and fluid openings, lines, and hoses are capped or plugged during maintenance procedures.
5. **IDENTIFICATION.**
 - a. During disassembly, tag parts to ensure proper assembly.
 - b. During disassembly, tag leads on electrical parts to ensure proper assembly. Tag each lead, as it is removed, with numbers from wiring diagrams and terminals.

6. **TORQUING.** Where needed, torque values are listed in the maintenance task. When torquing, use one of the star pattern sequences below unless otherwise stated in the maintenance task.

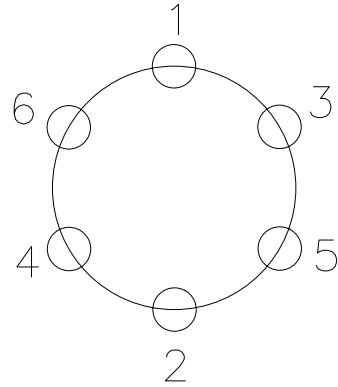

6-HOLE PATTERN

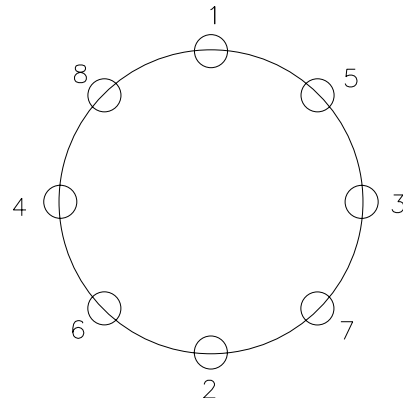

8-HOLE PATTERN

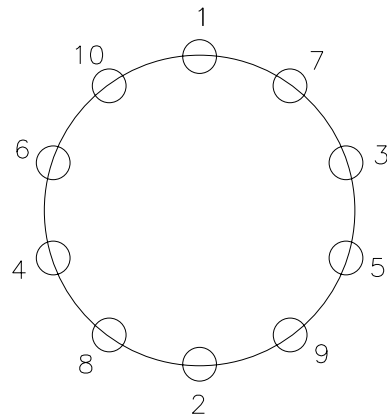

10-HOLE PATTERN

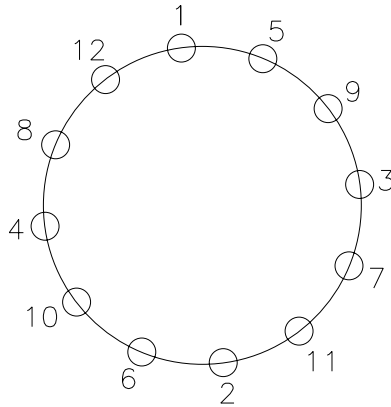

12-HOLE PATTERN

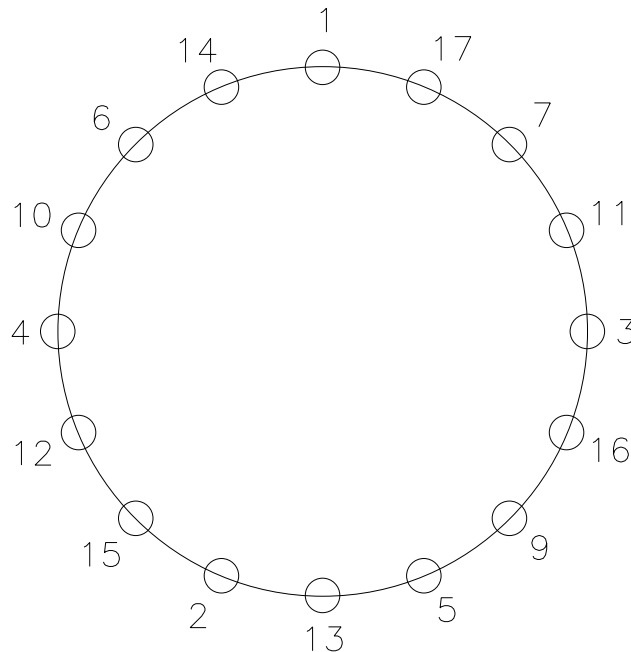

17-HOLE PATTERN

7. TORQUE WRENCH ADAPTERS AND CONVERSION FORMULA.

- a. Torque wrench adapters (extensions) are used to tighten screws and nuts to specific values that cannot be reached with a regular socket on the end of a torque wrench. This makes the dial or scale reading less than the actual torque applied to the screw or nut. When using an adapter, determine the dial or scale reading as follows:
 - 1) Check your manual for specific torque value to which the screw or nut should be tightened.
 - 2) Measure the length of your torque wrench, from the center of the handle (point A) to the center of the socket (point B). Record this measurement.
 - 3) Multiply the above measurement by the desired torque. Record this sum.
 - 4) Measure length of adapter from socket end (point C) to screw or nut end (point D). Record this measurement.

**PREVENTIVE MAINTENANCE CHECKS AND SERVICES (PMCS), INCLUDING
LUBRICATION INSTRUCTIONS — Continued**

0014 00

- 5) Add length of adapter (Step 7a4) to the length of the torque wrench (Step 7a2). Record this sum.
- 6) Divide the sum found in Step 7a3 by the sum found in Step 7a5.
- 7) The sum found in Step 7a6 is your torque wrench setting. Set your dial.

NOTE

Setting the torque wrench dial at the reading found in Step 7a7 will deliver the required torque at the end of your adapter.

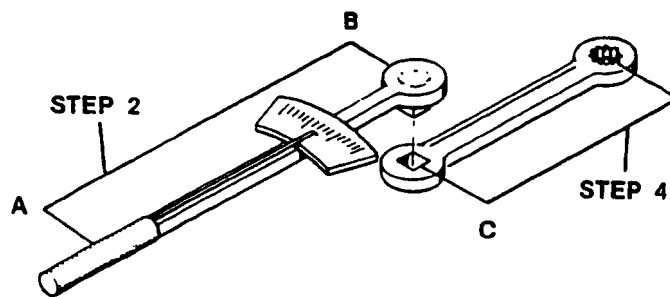

Example: (Metric equivalents omitted for clarity).

- 1) 40 lb-ft required.
- 2) 12 inches.
- 3) $12 \times 40 = 480$.
- 4) 4 inches.
- 5) $12 + 4 = 16$ inches.
- 6) $480/16 = 30$ lb-ft.
- 7) Torque wrench dial setting = 30.

CLEANING

8. **GENERAL CLEANING.** Cleaning is very important. All parts must be cleaned well and kept clean during maintenance. Dirt or foreign matter can cause malfunctions and equipment failure. General cleaning procedures are detailed in the following steps. Special cleaning procedures are covered in the task relating to the specific part. Clean after repair and before assembly.

WARNING

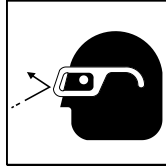

Air pressure in excess of 30 psi (207 kPa) can injure personnel. Do not direct pressurized air at yourself or others. Always wear goggles.

WARNING



Lye or caustic substances will damage metal surfaces. Do not use lye or caustic mixtures to clean metal surfaces.

CAUTION

Cleaning solvent causes leather, rubber, and synthetic materials to become brittle. Do not use cleaning solvent to clean seals, cables, and flexible hoses.

- a. **CLEAN EVERY PART.** Clean every part well after disassembly and before assembly or installation. Clean parts such as housings, covers, and dipsticks before disassembly. Avoid getting dirt and foreign matter in a system. Inspect and cap all air and fluid openings, lines, and hoses.
- b. **HANDLE WITH CARE.** Use care when handling parts during cleaning and maintenance. Nicks, scratches, dents, and burrs can prevent proper assembly or cause malfunctions after assembly. Keep hands free of grease. Grease collects dirt. Cover or wrap parts to protect from dirt.
- c. **AVOID ABRASIVES.** Except where specially called for in a task, don't use abrasives, files, wire brushes, or sharp tools. On some surfaces, finish is important to the operation of close fitting parts.
- d. **REMOVAL AGENTS.** Remove gum or old grease deposits by soaking parts in cleaning compound (WP 0122 00, Item 8). Scrub with a brush. Use crocus cloth (WP 0122 00, Item 11) to remove minor surface defects.
- e. **STEAM CLEANING.** If steam cleaning is used, dry clean parts at once with compressed air. Apply a thin film of clean oil to surfaces that are not painted to prevent rusting. Never use lye or caustic mixtures that will corrode or etch metal surfaces.
- f. **LUBRICATION OF NEW BEARINGS.** See TM 9-214 for cleaning and lubrication procedures. Bearings that have been in service should also be lubricated.
- g. **CASTINGS.**
 - 1) Clean inner and outer surfaces of casting with cleaning compound (WP 0122 00, Item 8). Dry casting with compressed air.
 - 2) Remove sludge and gum deposits with a brush.

**PREVENTIVE MAINTENANCE CHECKS AND SERVICES (PMCS), INCLUDING
LUBRICATION INSTRUCTIONS — Continued**

0014 00

- 3) Blow out all tapped holes and armor mounting inserts with compressed air.
- h. **BALL BEARINGS.** Bearings require special cleaning techniques. See TM 9-214 for cleaning and maintenance procedures for ball bearings.
- i. **OIL PASSAGES.**
 - 1) Make sure all oil passages are not clogged.
 - 2) Clean oil passages and break up any sludge or gum deposits.
 - 3) Flush oil passages with cleaning compound (WP 0122 00, Item 8). Dry parts with compressed air.
- j. **OIL SEALS, ELECTRICAL CABLES, AND FLEXIBLE HOSES.** Clean seals, cables, and flexible hoses with detergent (WP 0122 00, Item 14) and water. Dry parts with wiping rag (WP 0122 00, Item 36).
- k. **INSERTS.** Blow out insert holes with compressed air.
- l. **GASKETS.** If gasket is being removed, scrape old gasket material and sealant off mating surface. Clean mating surface with cleaning compound (WP 0122 00, Item 8). Dry with wiping rag (WP 0122 00, Item 36).

INSPECTION

9. All parts must be inspected with care. Replace parts if damage or wear exceeds allowable limits.
 - a. **GENERAL.** Procedures for inspection will be the same for most parts. General inspection procedures are given in the following steps. Special inspection procedures are covered in the task as needed.
 - b. **CASTINGS.**
 - 1) Use magnetic particle inspection equipment to check ferrous castings for cracks. Use a magnifying glass and strong light to check nonmetal castings for cracks. Check areas next to studs, threaded inserts, sharp corners, and fillets.
 - 2) Inspect all castings and forgings for breaks, cracks, and wear or scoring that would impair function.
 - 3) Inspect machined surfaces for nicks, burrs, and raised metal. Mark damaged areas for repair.
 - 4) Use straightedge to check all mounting flanges on housings and supports for bends. Inspect mating flanges for stains which would indicate oil leakage.
 - 5) Inspect all threaded parts for damaged or stripped threads.
 - c. **ROLLER AND BALL BEARINGS.** Inspect bearing races for wear and color changes due to heat. See TM 9-214 for inspection procedures for ball bearings.
 - d. **NEEDLE ROLLER BEARINGS.** Inspect bearings for free and smooth rotation, and broken or missing rollers. Also look for tightness of fit in bearing bores. Inspect bearing races for wear and color changes due to heat. See TM 9-214 for inspection procedures.
 - e. **STUDS.** Inspect all studs for stripped or damaged threads, bent or loose condition, and signs of stretching.
 - f. **GEARS.**
 - 1) Use magnetic particle inspection equipment to check all gears for cracks.
 - 2) Inspect gears for burrs, wear, cracked or broken teeth, and pitting at tooth contact areas.
 - g. **BUSHINGS AND BUSHING TYPE BEARINGS.**
 - 1) Check all bushings and bushing type bearings for secure fit in casting. Check for color changes which could mean overheating. Inspect for size, scoring, out of roundness, burrs, sharp edges, and signs of seizing.
 - 2) Check for dirt in oil holes and in bushing type bearings. Oil holes and grooves must be clean and not damaged.

**PREVENTIVE MAINTENANCE CHECKS AND SERVICES (PMCS), INCLUDING
LUBRICATION INSTRUCTIONS — Continued**

0014 00

- h. **OIL SEALS.**
 - 1) Inspect feather edge of oil seals for tears, fraying, hardening, and cracking.
 - 2) Replace metal covered oil seals when there are signs of damage or oil leakage.
- i. **CORE HOLE PLUGS.** Inspect core holes for signs of leakage. Replace damaged core hole plugs.
- j. **INSERTS.**
 - 1) Inspect inserts for cracks and stripped or damaged threads.
 - 2) Check inserts for loose fit.
 - 3) Inspect armor mounting inserts and hull screw holes for loose or missing plugs and setscrews, as required.
- k. **GREASE SEALS, PREFORMED PACKING, AND GASKETS.**
 - 1) Inspect seals that are composition type, rings, and preformed packing for wear, brittleness, cracks, cuts, and damage.
 - 2) Inspect lip seals for cracks, wear, cuts, and brittleness. Inspect springs and seal shells for damage.
 - 3) Gaskets and seals on electrical parts may be reused. Inspect gaskets and seals for wear, nicks, cuts, and torn or missing gasket material. Replace gasket, if needed.
- l. **SPLINED PARTS.** Inspect splined parts for burrs, wear, and twisted, cracked or broken splines.
- m. **THREADED PARTS.** Inspect all threaded parts for burrs, and stripped or damaged threads.
- n. **RETAINING RINGS.** Inspect retaining rings for nicks, burrs, defects, loss of tension, or wear.
- o. **SPRINGS.** Inspect springs for wear, defects, breaks, and loss of tension or compression. Inspect springs using a spring tester.
- p. **SHAFTS AND SPINDLES.** Inspect shafts and spindles for excessive wear, binding, scores, cracks, burrs, and obstructed oil passages.
- q. **ELECTRICAL PARTS.**
 - 1) Inspect electrical parts before you install them. Look for mildew, and corroded or burned parts.
 - 2) Inspect electrical parts for pinched or loose wires, and for cracked or broken wires, circuit cards, relays, and connectors.
 - 3) Inspect insulation and heat shrink tubing for cracks, tears, burns, or missing material.

REPAIR

- 10. **GENERAL REPAIR.** General repair procedures are given in the following steps. Special repairs are covered in the task. After repair, clean all parts well.
 - a. **CASTINGS.**
 - 1) Replace all cracked or broken castings.
 - 2) Repair minor damage to machined surfaces of castings with crocus cloth (WP 0122 00, Item 11). Replace any part with defects that cannot be corrected or which will impair function.
 - 3) Repair minor surface bends by working bent surface of casting across sheet of crocus cloth (WP 0122 00, Item 11) on surface plate. Replace bent castings which would impair assembly or function.
 - 4) Repair damaged pipe or screw threads with correct tap or die.
 - b. **BALL BEARINGS.** See TM 9-214 for inspection and maintenance of ball bearings.

**PREVENTIVE MAINTENANCE CHECKS AND SERVICES (PMCS), INCLUDING
LUBRICATION INSTRUCTIONS — Continued**

0014 00

- c. **NEEDLE ROLLER BEARINGS.** See TM 9-214 for inspection and maintenance of needle roller bearings.
- d. **STUDS.**
- 1) Replace all bent or loose studs, or studs which show signs of stretching.
 - 2) Repair minor thread damage with standard thread chaser.
 - 3) To remove studs, back out studs slowly with stud extractor to avoid heating and possible seizure. If studs are broken too short to use extractor, drill and extract studs with suitable remover. A short stud may be removed by welding nut to stud and removing with wrench.
 - 4) To replace studs, lightly apply antiseize compound to stud before you install it. Only standard studs are supplied for repair parts. If threaded hole is damaged beyond repair, drill and tap damaged hole. Install threaded insert in tapped hole.
- e. **GEARS.**
- 1) Replace gears that have worn, pitted or gouged teeth.
 - 2) Remove sharp burrs from gear teeth with crocus cloth (WP 0122 00, Item 11) dipped in cleaning compound (WP 0122 00, Item 8).

CAUTION

Damaged housing bore can cause equipment failure. Do not damage housing bore when cutting bushings.

NOTE

Do not remove bushings and bushing type bearings unless replacement is necessary and authorized. Removal usually damages these parts.

- f. **BUSHINGS AND BUSHING TYPE BEARINGS.**
- 1) Replace bushings and bushing type bearings if they are loose, scored, or have color change due to heat. When you replace bushings and bushing type bearings, check nearby parts for damage or wear.
 - 2) Remove bushings and bushing type bearings by pressing them out. Use a suitable arbor press or special tools. It may be necessary to remove bushings in blind holes with a saw, or by using a narrow cap chisel.
 - 3) Install bushings or bushing type bearings by aligning them in casting or retaining cage. Press bushing or bushing type bearings into place with suitable arbor press or with special tools.
- g. **OIL SEALS.** Oil seals must be replaced when thin feather edge is damaged, or when seal material is brittle.
- 1) Press damaged oil seal from casting. Be careful not to damage bore.
 - 2) When oil seal bore is damaged so an oil tight seal is impossible, replace casting or adapter. Remove slight nicks, burrs, and scratches with crocus cloth (WP 0122 00, Item 11) dipped in cleaning compound (WP 0122 00, Item 8).
 - 3) Install new oil seal in casting bore or adapter using suitable oil seal replacement tool.
- h. **INSERTS.** Replace insert when threads are stripped or when insert is cracked or loose.
- 1) Drill and remove damaged insert from casting.
 - 2) Install new insert in casting using suitable replacement tool.
 - 3) Install plugs in armor mounting inserts, as required.

**PREVENTIVE MAINTENANCE CHECKS AND SERVICES (PMCS), INCLUDING
LUBRICATION INSTRUCTIONS — Continued**

0014 00

- 4) Install setscrews in hull armor mounting screw holes, as required.
- i. **GREASE SEALS, PREFORMED PACKING, GROMMETS, AND GASKETS.** Seals, preformed packing, grommets, and gaskets should be replaced when removed unless otherwise stated in the maintenance task. They should not be reused.

**PREVENTIVE MAINTENANCE CHECKS AND SERVICES (PMCS), INCLUDING
LUBRICATION INSTRUCTIONS — Continued**

0014 00

j. SPLINED PARTS.

- 1) Remove burrs from splined parts with a soft honing stone.
- 2) Replace parts that are worn or have twisted, cracked, or broken splines.

NOTE

Chase threads with a used tap or die. A new tap may cut undersize, while a new die may cut oversize.

k. THREADED PARTS. Repair all parts that have stripped or damaged threads by chasing threads with a used tap or die. Replace parts that cannot be repaired.

l. RETAINING RINGS.

- 1) Retaining rings should be replaced when removed unless otherwise stated in the maintenance task. They should not be reused.
- 2) Some retaining rings are beveled on one side. When installing this type of ring, the beveled side must face the part to be retained.

m. SPRINGS. Discard springs that have defects. Load and height inspection data, where needed, are given in maintenance procedures.

n. SHAFTS AND SPINDLES.

- 1) Replace shafts and spindles that show signs of wear, binding, scores, cracks, burrs, or clogged oil passages.
- 2) Remove obstructions with compressed air or by probing with soft wire.
- 3) Remove burrs and minor surface defects with a crocus cloth (WP 0122 00, Item 11).

o. ELECTRICAL PARTS.

- 1) Replace corroded or burned parts and parts which show signs of mildew.
- 2) Tighten loose connections.
- 3) Replace cracked or broken wires, circuit cards, relays, and connectors.
- 4) Replace cracked, torn, or burned insulation and heat shrink tubing.

WELDING INSTRUCTIONS

11. Welding safety precautions and welding procedures are given in the following steps. Special instructions are covered in the task.

a. SAFETY PRECAUTIONS.

- 1) Wear clothing such as leather or heavy denim. Do not wear clothing with loose pockets, trouser cuffs, or short or rolled up sleeves.
- 2) Do not expose bare skin to welding arc.
- 3) Do not look directly at welding arc unless you are wearing a welding hood.
- 4) Wear flash goggles or tinted safety glasses (No.2) in welding area.
- 5) Disconnect power source before changing parts or making equipment repairs.
- 6) Do not touch mechanism or any part of the electrode.

**PREVENTIVE MAINTENANCE CHECKS AND SERVICES (PMCS), INCLUDING
LUBRICATION INSTRUCTIONS — Continued**

0014 00

- 7) Make sure welding area has plenty of fresh air without being drafty. remove all toxic and combustible materials.
- 8) Make sure all electrical and gas connections are tight.
- 9) Do not touch any metal in welding area with bare hands. Aluminum does not change color when hot.
- 10) Do not weld in the fuel compartment where sealing compound has been applied.
- 11) Use a welding screen to protect personnel from arc flash.

b. GENERAL WELDING PROCEDURES.

- 1) **BASIC WELDING REPAIRS.** Repairs are made on 5083 aluminum alloy using the MIG (Gas Metal Arc) welding method.
- 2) **CONTRACTION AND EXPANSION.** Aluminum welds contract about 6 percent in volume when they become solid. Welding at slow speed may cause too much heating of the area around the weld. This will cause the metal to expand too much or melt. It will then cause cracking upon cooling.
- 3) **FILLER WIRE.** Always use clean wire. Filler wire polluted by grease, oil, dust, or shop fumes causes porous welds. After welding, cover wire to prevent pollution. Store covered wire in warm, dry place.
- 4) **CLEANING OF WELDED SURFACES.** Remove oxides, grease, oil films, paint, and all foreign matter from joint before welding. Wipe edges of joint with a clean cloth dipped in cleaning compound, and let dry before welding. Sand with disk sander, or brush surface with clean stainless steel wire brush to remove oxide. Clean up weld area and touch up paint all bare metal (see TM 43-0139).
- 5) **FIT-UP AND TACKING.** Good joint fit-up makes welding easier, saves filler wire and gas, and helps get higher quality welds. You must tack weld to hold the joint members in place if you don't have jigs. Tack welds should be small, neat, and placed right to keep parts lined up before and during welding.
- 6) **WELDING UNEQUAL SECTIONS.** When welding unequal sections, direct arc against heavier piece to fuse the two edges evenly. Watch weld pool edge rather than arc to ensure weld pool edges fuse right.
- 7) **MULTI-PASS WELDING.** Make sure edges of weld pool fuse right. Watch weld pool rather than arc. Any oscillating or weaving motion should be slight, smooth, and slow. Brush material with clean stainless steel wire brush after each pass. On small weldments, lower amperage slightly after each pass if welding members become too hot.

CAUTION

Heat distortion during welding will damage aluminum castings. Do not attempt to repair aluminum castings by welding.

c. ALUMINUM CASTINGS

- 1) **FINAL DRIVE CASTING.** Welding in final drive aluminum casting is not authorized. Do not attempt to weld on final drive housing assembly.

d. MAGNESIUM CASTINGS

WARNING

Magnesium may catch on fire if welded or exposed to high temperatures. Do not weld on magnesium castings or expose them to high temperatures.

WARNING

Fine particles of magnesium can catch fire and burn you. Be very careful when filing or grinding on magnesium. Use grinding equipment marked **FOR MAGNESIUM GRINDING ONLY**. Keep a Class D fire extinguisher close by.

WARNING

Water and foam type fire extinguishers will cause magnesium fires to flare up. Use a Class D fire extinguisher or a sodium chloride base dry powder to fight magnesium fires.

WARNING

Improper disposal of magnesium can cause a fire or explosion. Do not expose magnesium to high temperatures. Let magnesium dry before placing in sealed metal containers. Label containers and ship to a Class 1 hazardous waste disposal site.

- 1) **FAN CASTINGS.** Welding on fan magnesium castings is not authorized. Do not attempt to weld on these parts.
- 2) **FILING OR GRINDING MAGNESIUM.** You must observe the following safety precautions when filing or grinding on magnesium:

**PREVENTIVE MAINTENANCE CHECKS AND SERVICES (PMCS), INCLUDING
LUBRICATION INSTRUCTIONS — Continued**

0014 00

- a) Use grinding equipment marked. **FOR MAGNESIUM GRINDING ONLY**
- b) Use a suitable coolant when grinding magnesium to keep temperatures below ignition point.
- c) Keep tools used on magnesium sharp.
- d) Keep a Class D fire extinguisher nearby for use on magnesium fires.
- e) Wear outer clothing of fire retardant cloth or leather. Brush clothing often to remove magnesium particles.
- f) Clean work area often. Do not let magnesium particles build up.
- g) Dispose of magnesium chips and filings according to regulations.

WARNING



Fuel fumes can explode and burn you. Before welding: Drain all fuel. Disconnect and cap all fuel and vent lines. Purge fuel residue and fumes by steam cleaning. Purge air from fuel tank with CO₂.

e. **FUEL TANKS**

- 1) You must observe all safety precautions when working with fuel or fuel lines.

WARNING

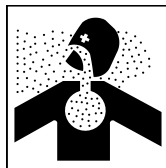

Do not weld on plastic molding material parts. Welding on plastic molding material parts creates toxic fumes. Fumes are hazardous to your health and can result in death.

- f. **PLASTIC MOLDING MATERIAL PARTS.** The following is a list of plastic molding material parts and their location on the carrier:
 - 1) Driver's power plant compartment access panel.
 - 2) Power plant rear compartment access panel.
 - 3) Driver's seat upholstered backrest.
 - 4) Trim vane rear pod.
 - 5) Trim vane front pod.
 - 6) All armor.

g. MIG WELDING METHOD.

- 1) MIG (Metal-Inert-Gas) welding. This process uses a DC power source, control panel, and a welding gun. The gun feeds a consumable bare electrode at a given rate into a molten pool beneath a blanket of inert gas. When an arc is struck, a molten pool forms at once. Move the welding gun along the joint line at a rate that shapes the right size bead. The covering inert gas keeps air from polluting the welding zone. No flux is needed.
- 2) Lead angle and cant angle. Place gun at a lead angle of 10 deg to 15 deg off vertical. Point gun in direction of weld travel for good gas coverage, cleaning, and preheating of material. Place gun at a cant angle of 90 deg. to parent metal so filler wire and arc are directed towards apex of groove. This will give equal fusion on both sides of material, even weld buildup, good gas coverage, and equal penetration.

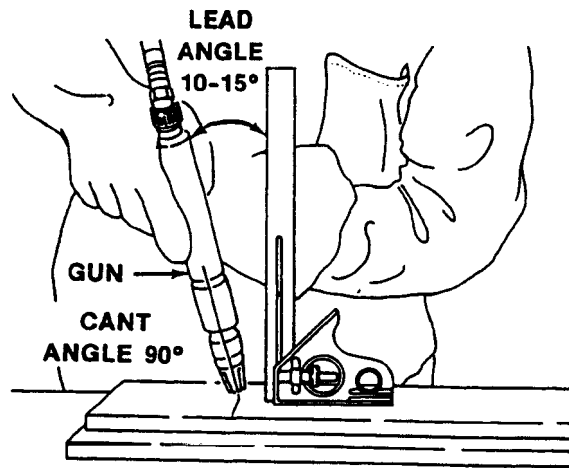

- 3) Nozzle clearance. Keep nozzle clearance of 1/2 to 5/8 inch (12 to 16mm) for good gas coverage. Wrong nozzle clearance will cause the following:

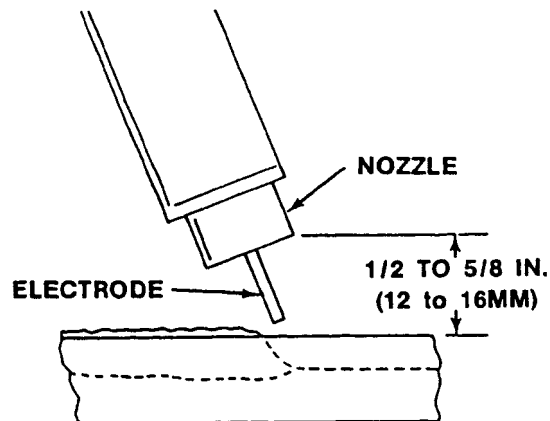

- a) Oxide deposits in the weld bead.
- b) Force gas bubbles into the weld.
- c) Prevent cleaning action on the material in front of the weld pool.

**PREVENTIVE MAINTENANCE CHECKS AND SERVICES (PMCS), INCLUDING
LUBRICATION INSTRUCTIONS — Continued**

0014 00

- 4) Arc length. You will hear a smooth hissing or buzzing sound when the right arc length is struck.
- 5) For further welding instructions, see TM 9-237.

12. FLUID LEAKS AND CHECKING FOR LEAKS**NOTE**

You are allowed to operate equipment with minor leaks (Class I or II). You must consider how much fluid the item or system being checked or inspected can hold. When in doubt notify your supervisor. When operating equipment with Class I or II leaks, continue to check fluid levels as required in your PMCS. Report Class III or fuel leaks to your supervisor, or notify unit maintenance for corrective action right away.

- a. **GENERAL.** Fluid leaks in hoses and fluid lines affect the carrier parts operation.
- b. The types and classes of leaks follow:
 - 1) **CLASS I.** Fluid seepage is not great enough to form drops, but is shown by wetness or color changes.
 - 2) **CLASS II.** Fluid leakage is great enough to form drops. Drops do not drip from the item being checked or inspected.
 - 3) **CLASS III.** Fluid leakage is great enough to form drops that fall from the item being checked or inspected.
- c. **CHECKING FOR LEAKS AFTER A MAINTENANCE TASK.** After doing maintenance on a part which involves hoses or fluid lines, check for leaks. If leaks occur after you have done a replace or repair task, find the source of the leak. Correct the problem. Follow these procedures:
 - 1) Do visual inspections to find the source of the leak.
 - a) Check for cracks on housing or cover.
 - b) Check that screws and any connections are not loose, or overtight.
 - 2) If you cannot see the source of the leak, check the following items:
 - a) Check that preformed gasket is not bent, or pinched.
 - b) Check machined surfaces for fit and cleanliness.
 - 3) If leak persists, notify supervisor.

PREVENTIVE MAINTENANCE CHECKS AND SERVICES

There are no preventive maintenance checks and services (PMCS) or lubrication procedures required for the M113A3 FOV Carriers at the direct support maintenance level. For crew level PMCS and lubrication procedures, see your -10. For unit level PMCS and lubrication procedures, see your -20.

REPLACE ENGINE

0015 00

THIS WORK PACKAGE COVERS:

Removal (page 0015 00-2).
 Installation (page 0015 00-21).

INITIAL SETUP:

Maintenance Level

Direct Support

Tools and Special Tools

General Mechanic's Tool Kit (WP 0120 00, Item 62)
 Engine and Transmission Sling (WP 0120 00, Item 52)
 Plastic Face Hammer (WP 0120 00, Item 15)
 Hammer Face Holder (WP 0120 00, Item 22)
 Lifting device with rated capacity of 1700 lbs (772 kg)
 Magnetic Base Dial Indicator (WP 0120 00, Item 24)
 Torque Wrench (WP 0120 00, Item 73)

Materials/Parts

Antifreeze (WP 0122 00, Item 4)
 Antiseize Compound (WP 0122 00, Item 5)
 Engine and transmission oil (WP 0122 00, Item 13)
 Hydraulic fluid (WP 0122 00, Item 16)
 Cotter pin
 Gasket
 Locknut
 Locknut
 Locknut
 Locknut
 Locknut
 Locknut (2)
 Locknut (2)
 Locknut (2)
 Locknut (3)

Materials/Parts

Lockwasher
 Lockwasher
 Lockwasher
 Lockwasher (2)
 Lockwasher (3)
 Lockwasher (2)
 Packing
 Self-locking bolt (10)
 Tie strap (7)

Personnel Required

Track Vehicle Repairer 63H10
 Helper (H)

References

See your -10
 See your -20
 (Drawing 12474790)

Equipment Condition

Power plant removed (see your -20)
 Power plant on the power plant stand (WP 0068 00)
 Engine oil drained (see your -20)
 Hydraulic fluid drained (see your -20)
 Engine wiring harness removed (see your -20)
 Variable speed fan drive wiring harness, 3W1 removed
 (see your-20) (New Configuration).

NOTE

Old and New Configuration refers to variable speed fan drive configurations.

REMOVAL

1. Remove nut (8), lockwasher (9), ground lead (5) and circuit lead 771 (6) from generator (7). Discard lockwasher.

NOTE

Install covers on disconnected electrical cable connectors and components during maintenance.

Use tape, cloth, cardboard, or any appropriate material to prevent damage to components.

2. Disconnect leads (3) from generator main cable (4).

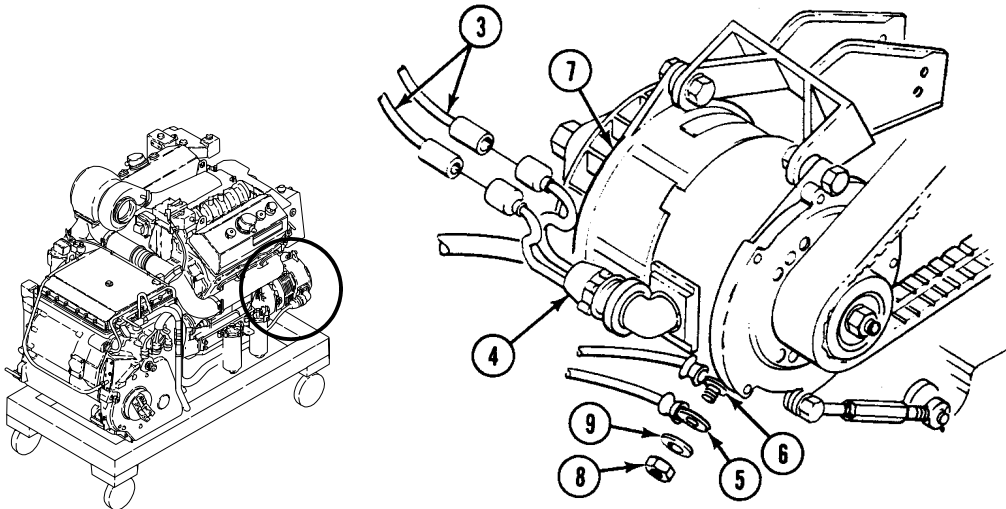

3. Disconnect lead (1) from airbox pressure transducer (2).

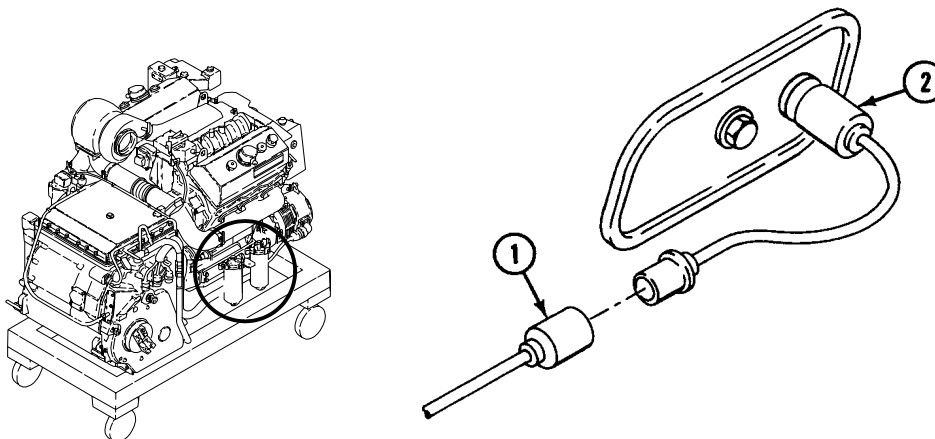

4. Disconnect lead (18) from fuel supply pressure transducer (19).
5. Disconnect lead (16) from fuel filter differential pressure switch (17).
6. Remove two tie straps (20) from harness. Discard straps.

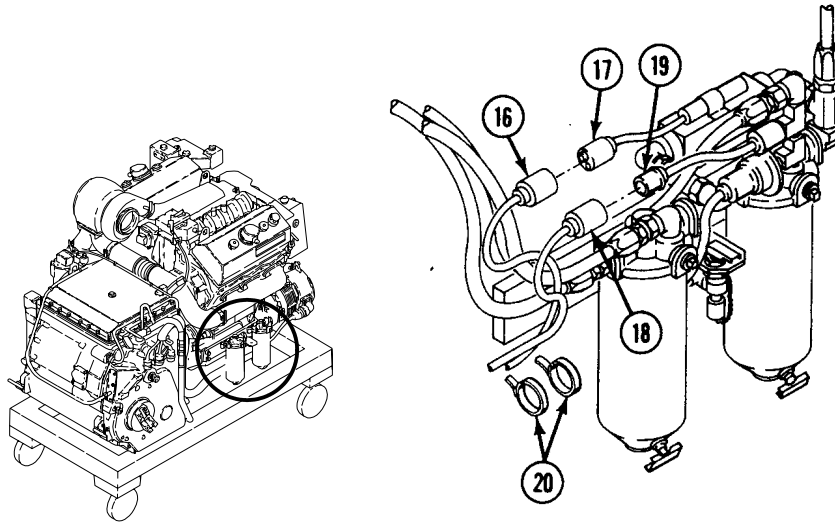

7. Remove nut (14), lockwasher (15), and leads (12) from starter (13). Discard lockwasher.
8. Remove two nuts (10), lockwashers (11), and leads (8) from starter solenoid (9) terminals. Discard lockwashers.

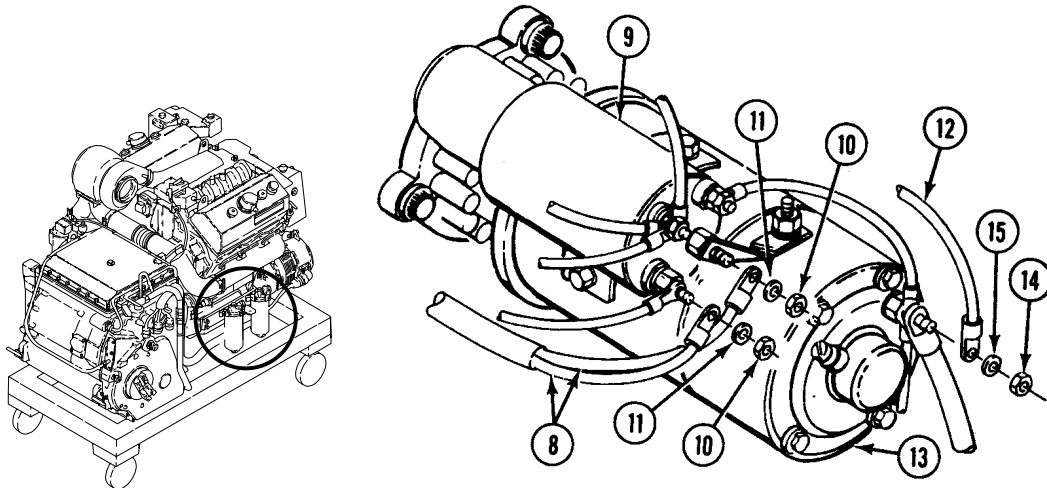

9. Disconnect lead (5) from turbo outlet pressure switch (6).

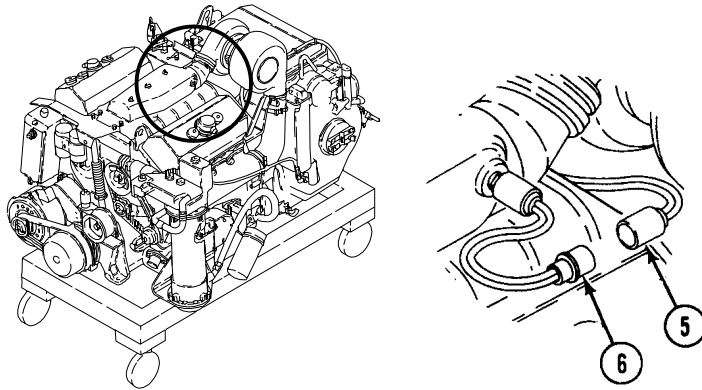

10. Disconnect lead (3) from fuel return pressure switch (4).
 11. Remove tie strap (7) from harness. Discard strap.

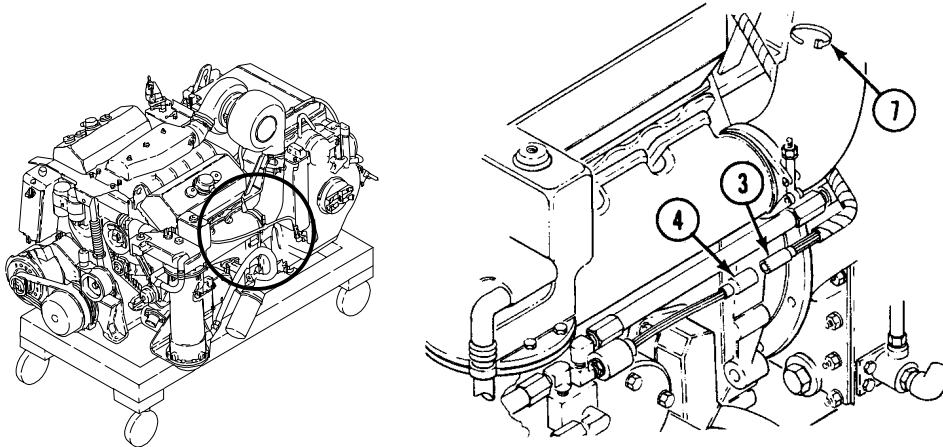

12. Disconnect lead (1) from pulse tachometer (2). Remove harness from engine.

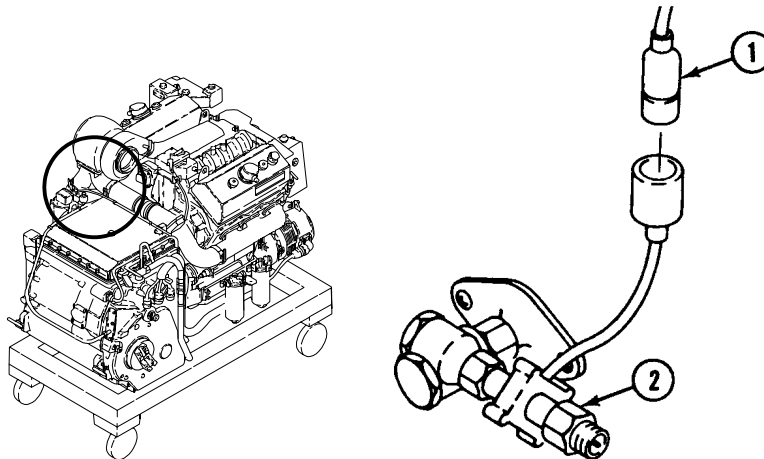

13. Remove screw (6), two washers (7), spacer (8), and turnbuckle (9) from generator (1).

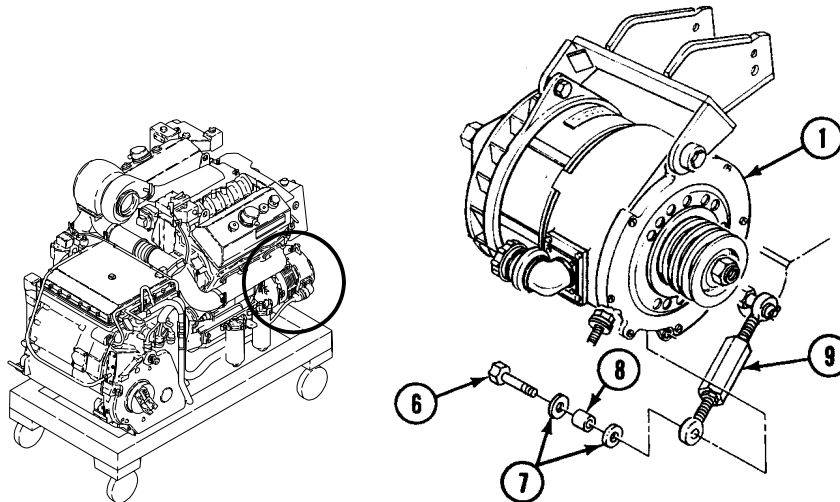

14. Remove two screws (1), locknuts (2), and three washers (3) from generator (4). Remove generator from bracket (5). Have helper assist. Discard locknuts.

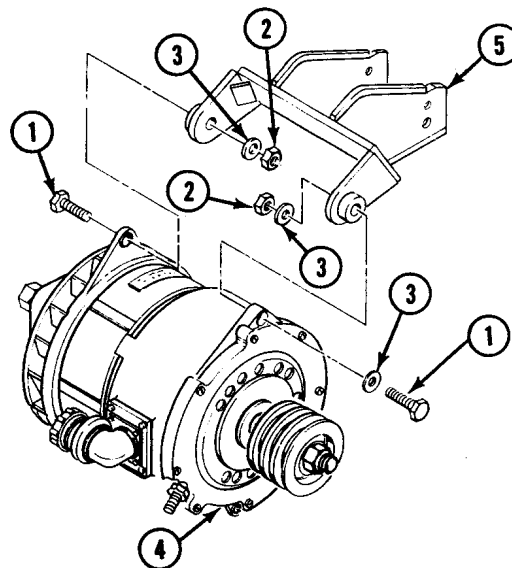

15. Remove three screws (6)(7)(8) and washers (9)(10)(11) from generator mounting bracket (5).
16. Remove generator mounting bracket (5) from engine block (12).

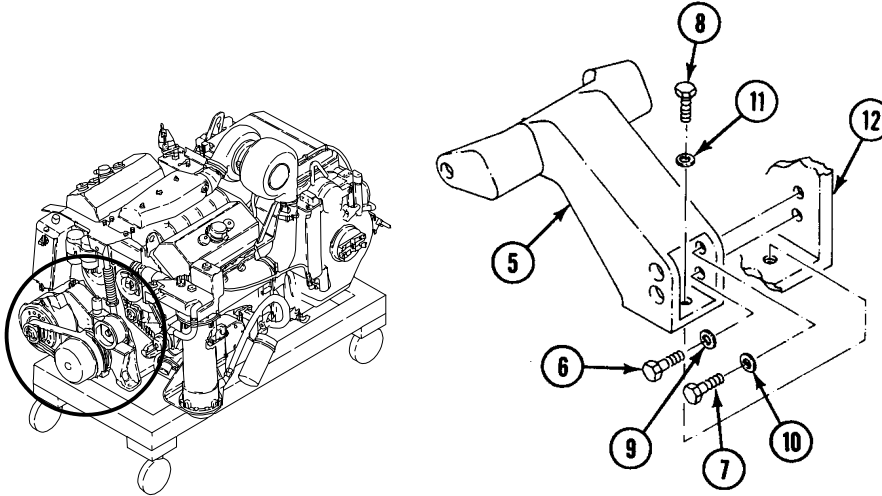

17. Remove two screws (10), four washers (11), two washers (12), four mounts (13), two blocks (14), two washers (15), and two locknuts (16) from engine. Discard locknuts.

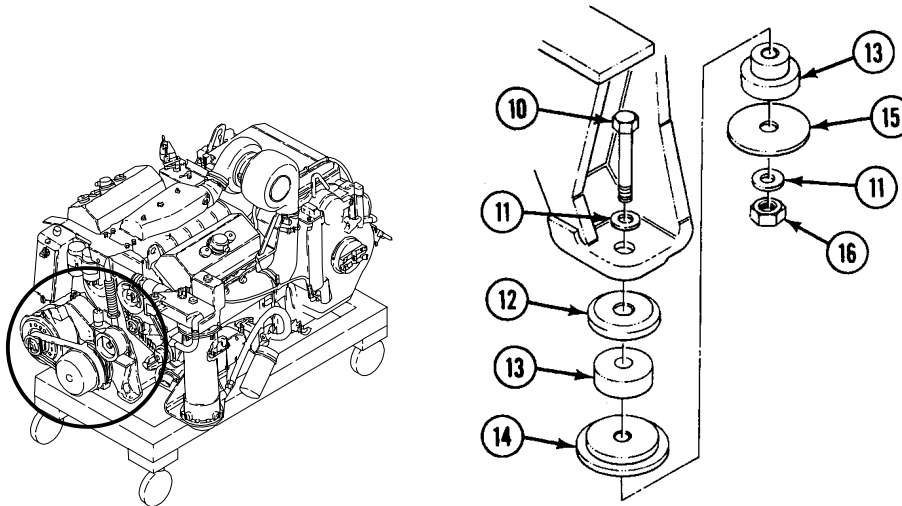

18. Remove cotter pin (1) and pin (2) from bracket (3). Discard cotter pin.
19. Remove screw (4), washer (5), locknut (6), and idler arm (7) from bracket (8). Remove idler arm with pulley and spring tensioner assembly. Discard locknut.

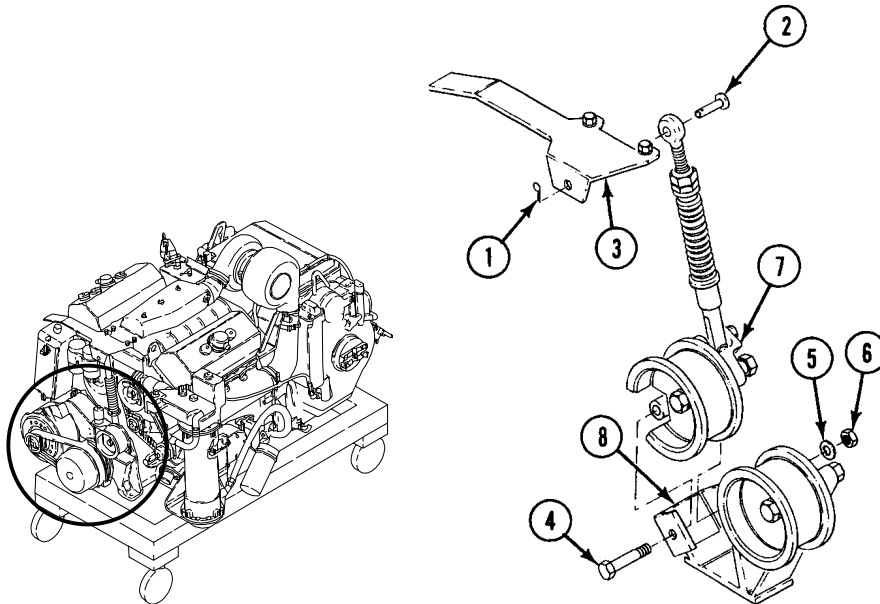

20. Remove locknut (9) and washer (10) from bolt (11). Discard locknut.
21. Remove bolt (11) and pulley (12) from bracket (13).

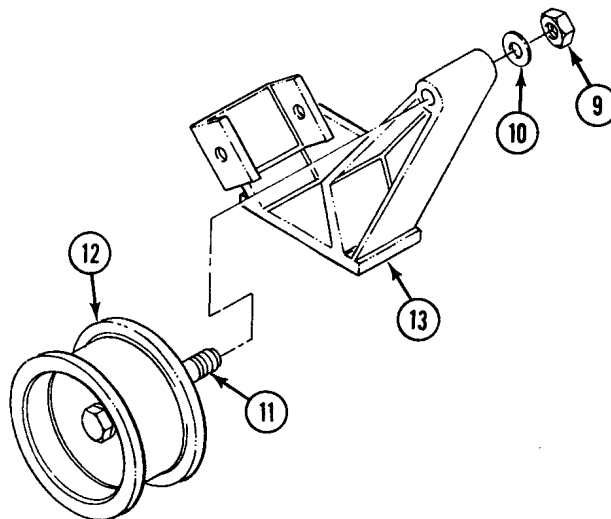

22. Remove tiedown strap (14) from hoses on variable speed drive (15).

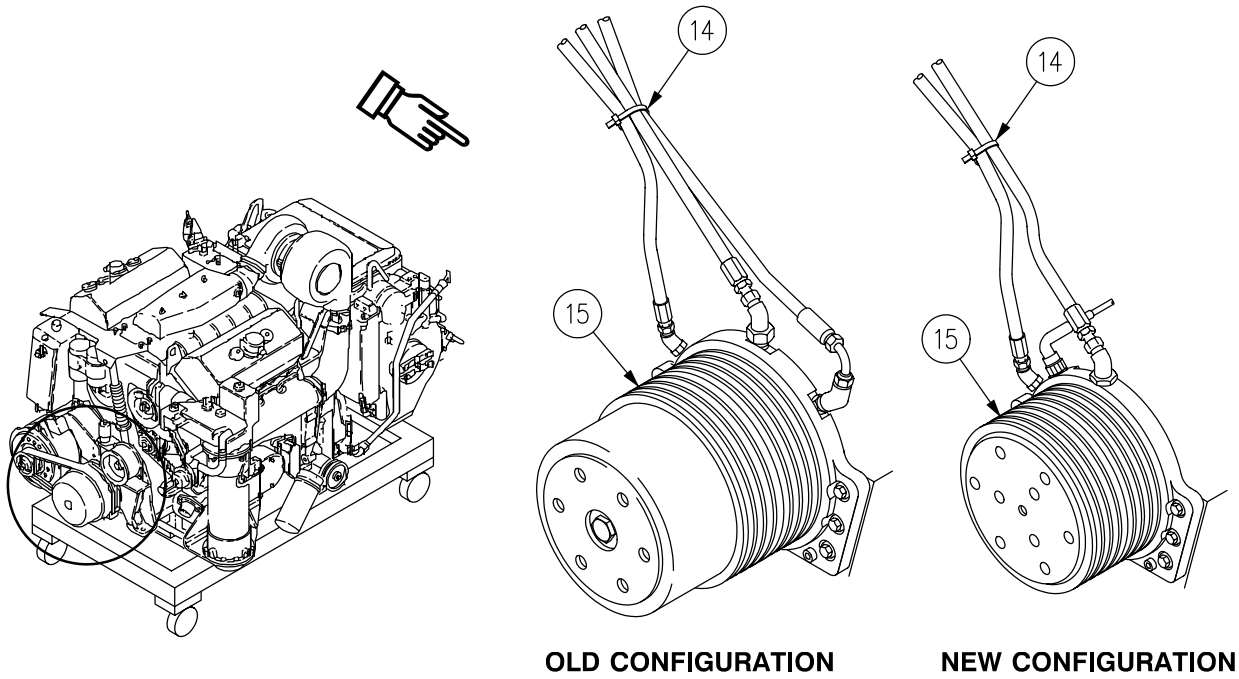

- 23. □ Remove lube port hose (1) from elbow (2) on variable speed drive (3) (old configuration).
- 24. □ Remove pressure hose (4) from elbow (5) on variable speed drive (3) (old configuration).
- 25. □ Remove return hose (6) from elbow (7) (old configuration) or adapter (7.1) (new configuration) on variable speed drive (3).

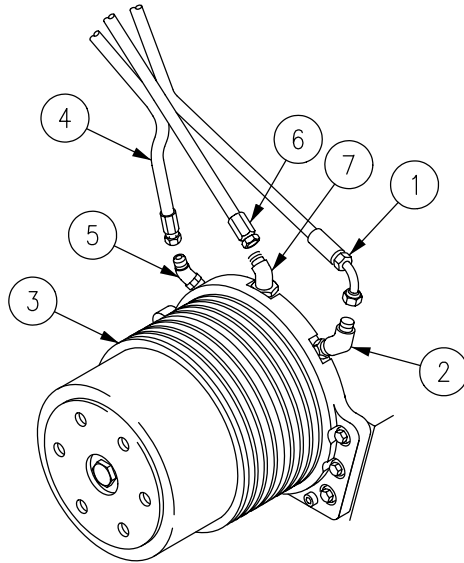

OLD CONFIGURATION

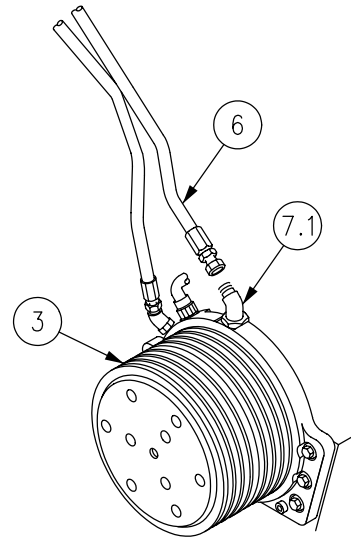

NEW CONFIGURATION



- 26. □ Remove supply hose (8) from elbow (9) on thermostatic switch (10) (old configuration) or valve (10.1) (new configuration).

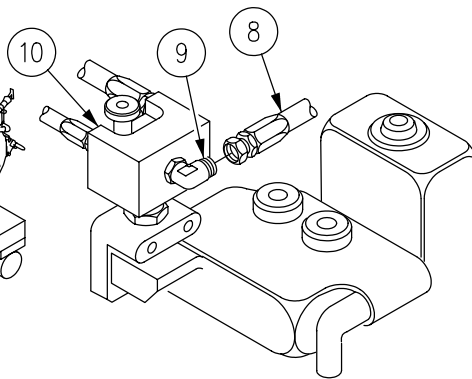
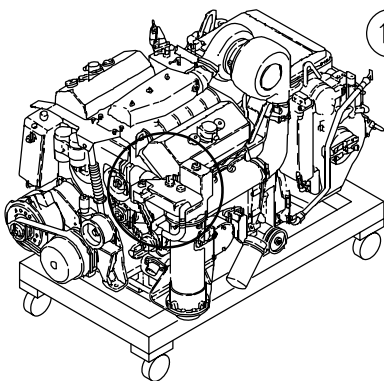

OLD CONFIGURATION

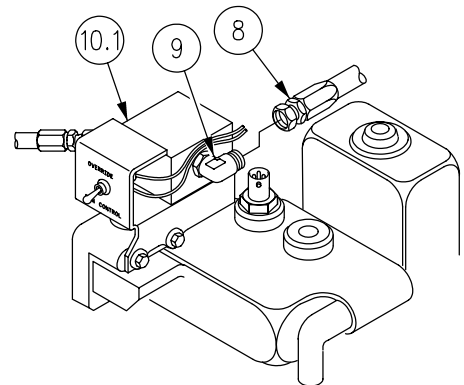

NEW CONFIGURATION



27. Remove supply hose (8) from elbow (11) on transmission (12).

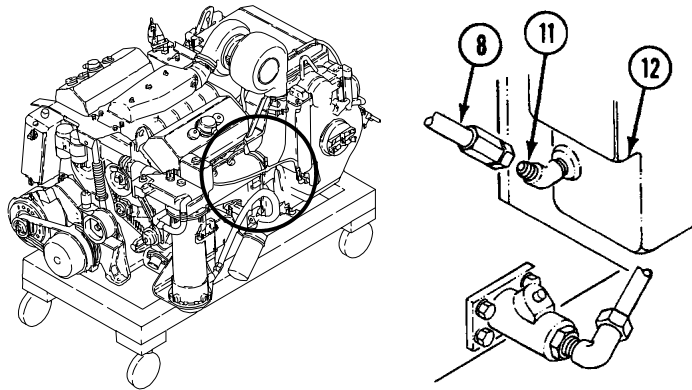

28. Remove two hoses (13) and (14) from adapters (15) and (16) (old configuration).

29. Remove thermostatic switch (10) and preformed packing (17) from power plant. Discard packing (old configuration).

30. Remove hose (17.1) from valve (17.2) (new nonfiguration).

31. Remove two screws (17.3), lockwashers (17.4) and bracket assembly (17.5). Discard lockwashers (new configuration).

32. Remove sensor (17.6) from thermostat housing (new configuration).

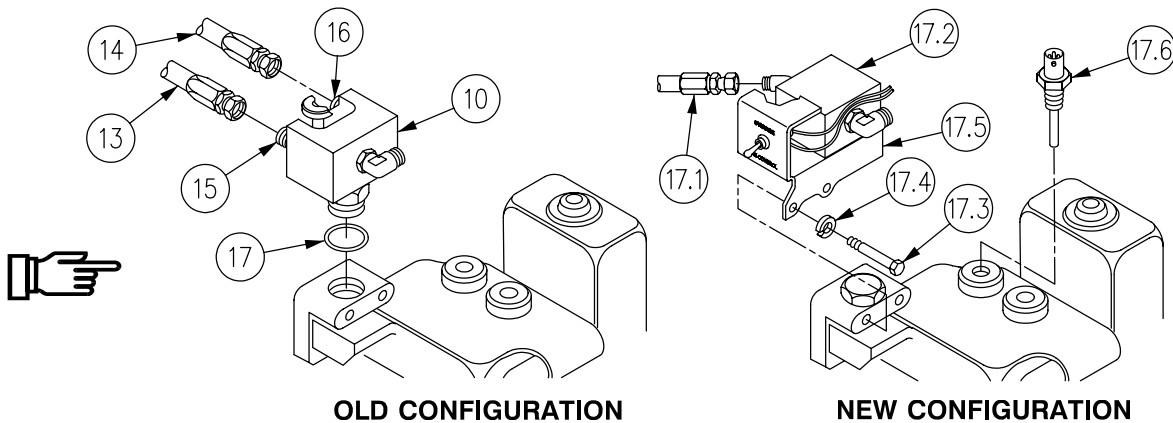

CAUTION

Cap or cover openings where oil lines or fittings have been removed.

33. Remove hose (1) from elbow (2) on transmission end cover (3).

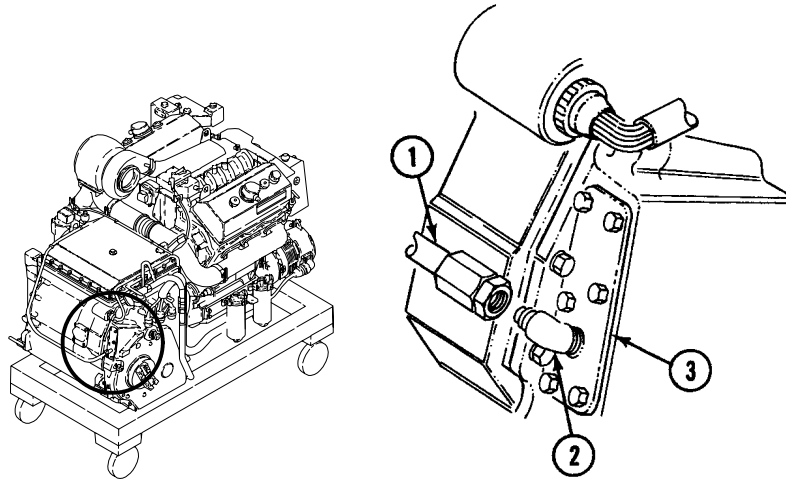

34. Remove screw (4), washer (5), clamp (6), and nut (7) that secure hose (1) to transmission.

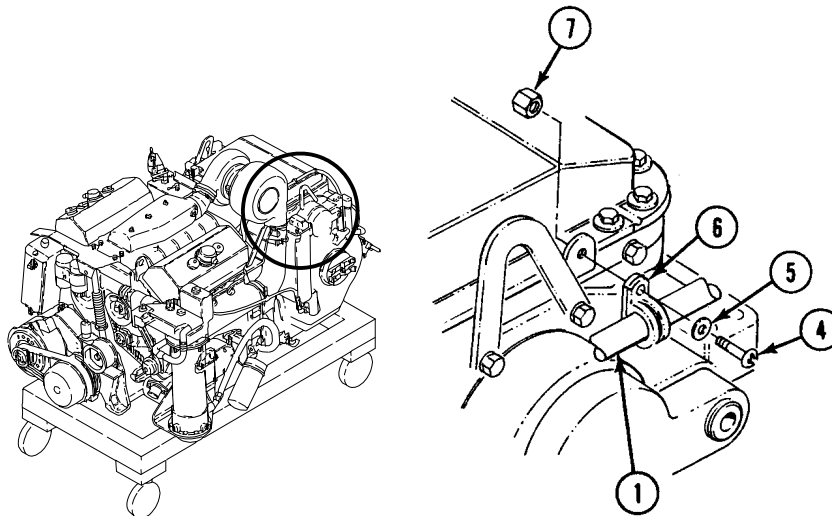

35. Remove screw (8), washer (9), and nut (10) from bracket (11). Remove bracket (11) with hoses (12), (13), and (1) from engine.

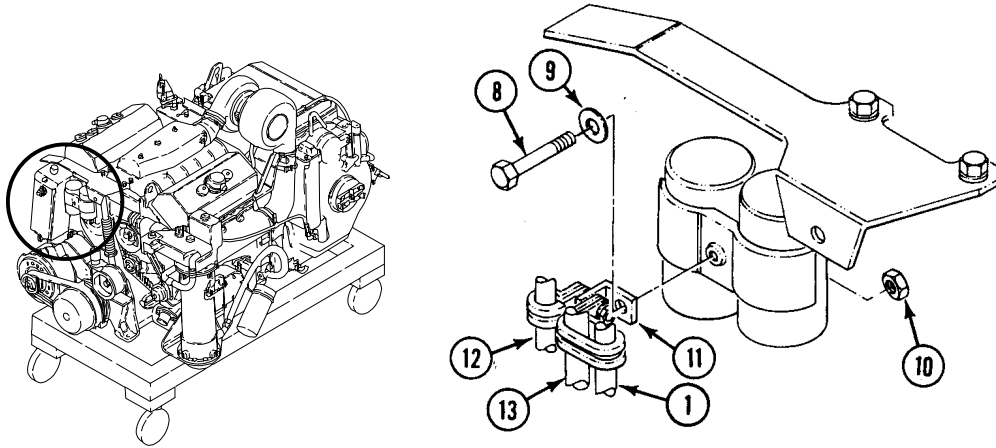

36. Remove six screws (1), washers (2), and variable speed drive assembly (3) from engine. Have helper assist.

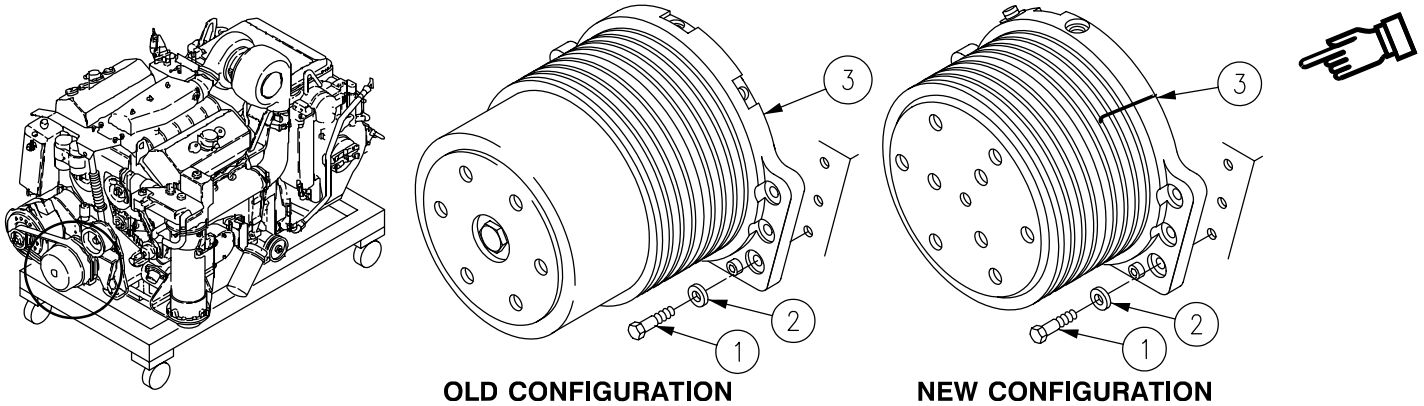

37. Remove variable speed drive adapter (WP 0016 00).
 38. Remove transmission oil outlet hose (4) from elbow (5), and remove elbow from tee (6) on oil cooler (7).
 39. Remove tee assembly (6) from oil cooler (7).

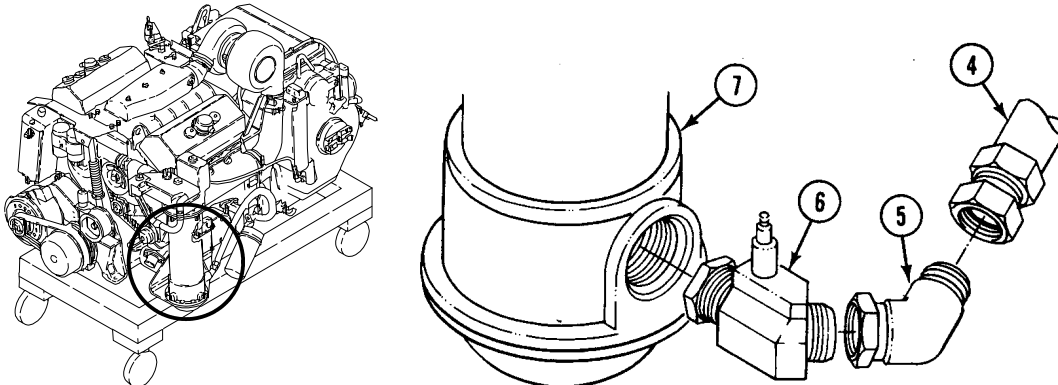

40. Remove oil inlet hose (8) from upper elbow (9) on oil cooler (7). Remove elbow assembly from oil cooler.

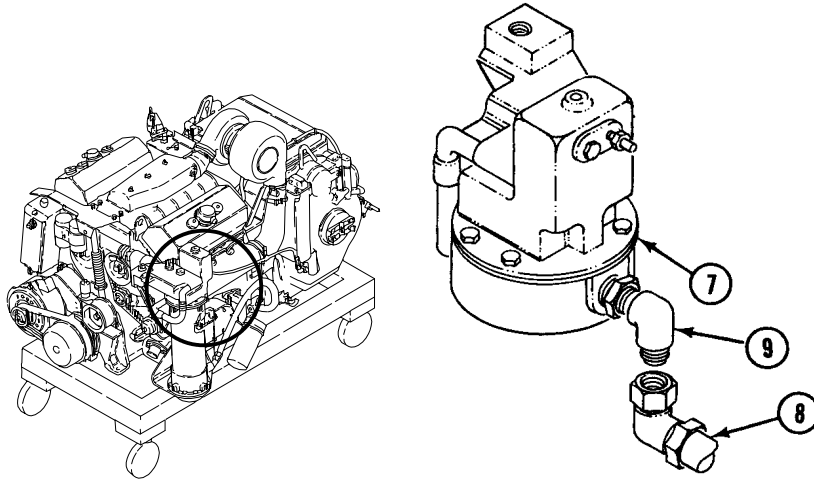

41. Remove locknut (10), screw (11), two washers (12), and clamp (13) from bracket (14). Discard locknut.

42. Remove screw (15), two washers (16) and bracket (14) from engine.

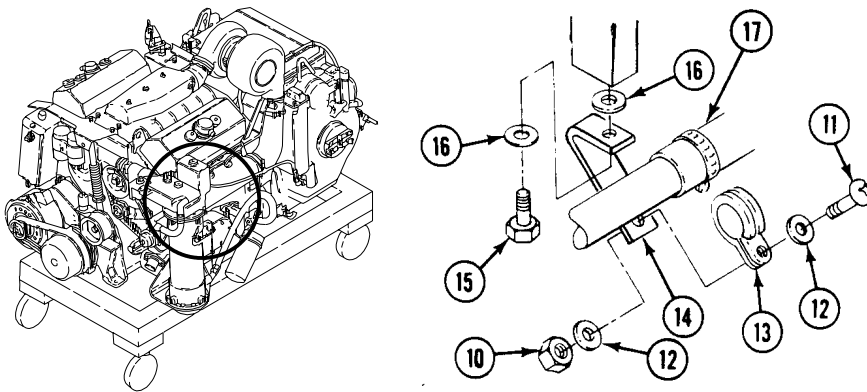

43. Remove two screws (1), four washers (2), two nuts (3), and bracket (4) from engine.

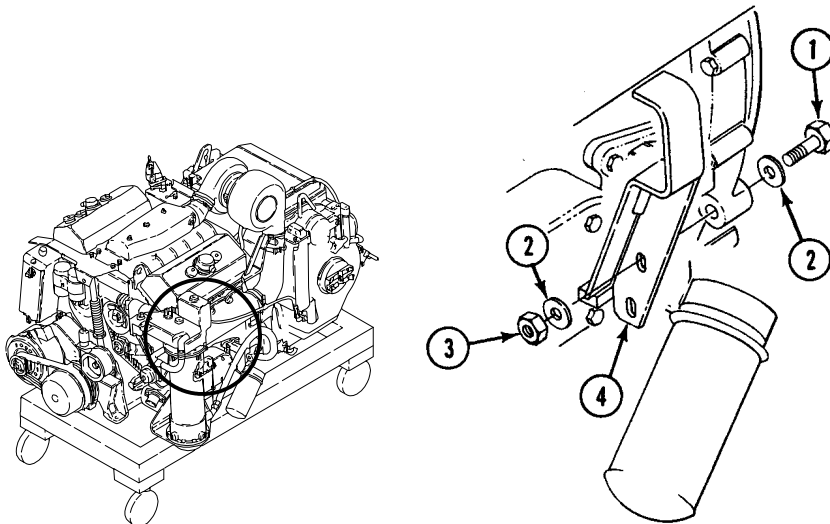

44. Disconnect fuel return hose (5) from elbow (6).

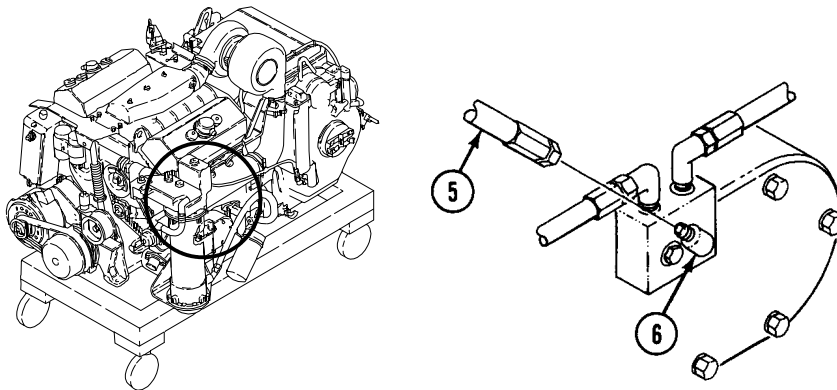

45. Disconnect supply hose (7) from elbow (8) on primary fuel filter (9). Remove elbow.

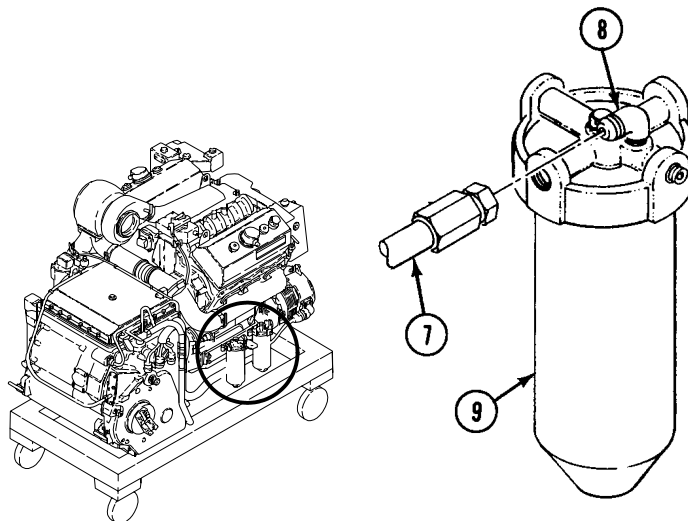

46. Disconnect hose (17) from adapter (18) on oil sample valve (4).
47. Disconnect hose (17) from adapter (12) and remove hose.
48. Remove screw (16), nut (15), two washers (14), and clamp (13) from transmitter (9).
49. Remove transmitter (9), adapter (11), tee (10), and adapter (12) from elbow (7).
50. Remove elbow (7) and nipple (8) from engine.
51. Remove screw (2), washer (3), and bracket (1) from engine.

52. Loosen jam nut (6) on valve (4) and remove valve from bracket (5).

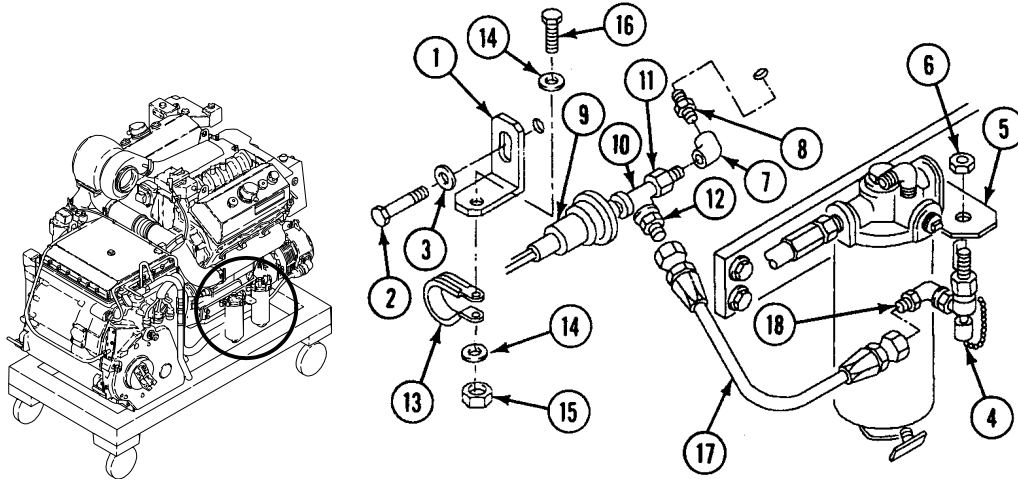

53. Remove three nuts (24), lockwashers (25), and circuit leads 74A (20), 74C (19), and 74D (18) from solenoid battery terminals (21) and (22) and starter (23). Discard lockwashers.

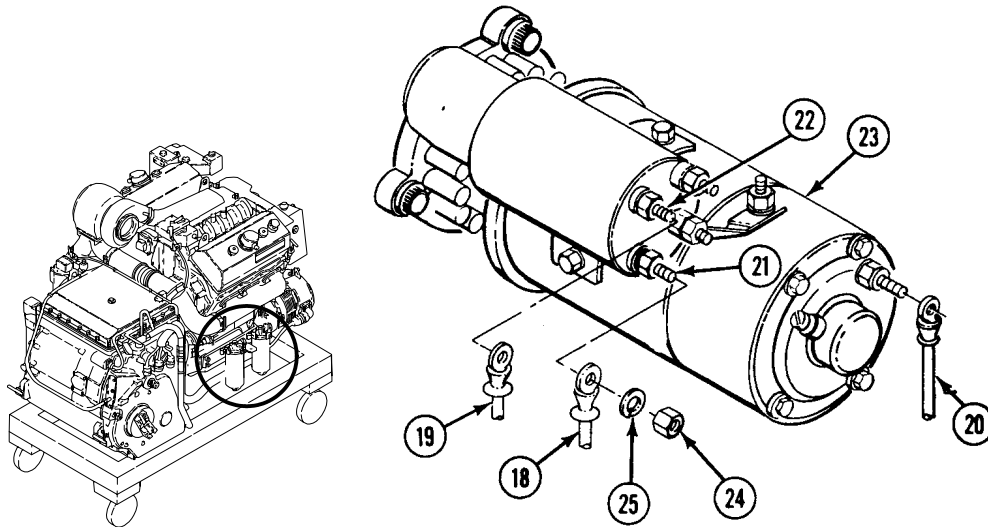

54. Remove two screws (15), washers (16), and locknuts (17) from bracket (14). Discard locknuts. Remove starter relay switch assembly (13) from engine.

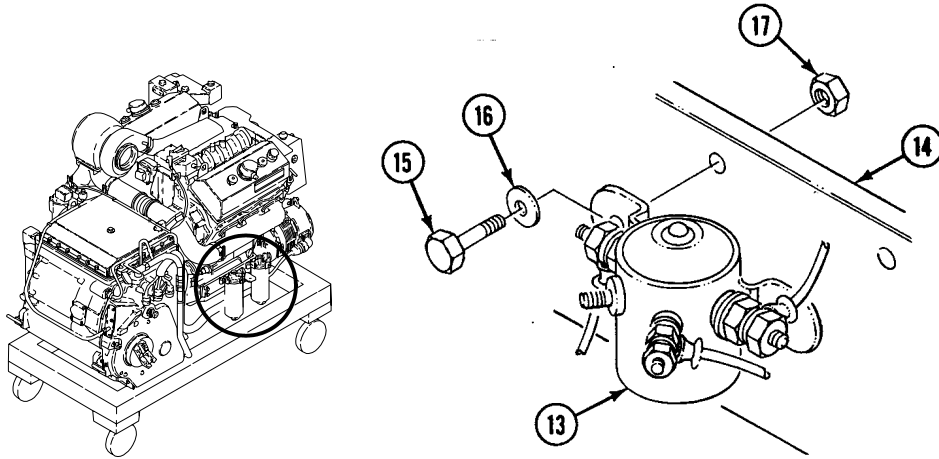

55. Remove switch (1) from tee (2) on secondary fuel filter (3) (old configuration).

56. Remove switch (3.1) from tee (3.2) on secondary fuel filter (3) (new configuration).

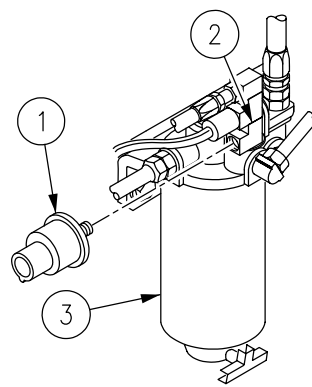
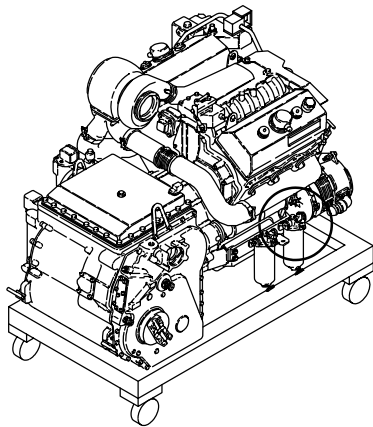

OLD CONFIGURATION

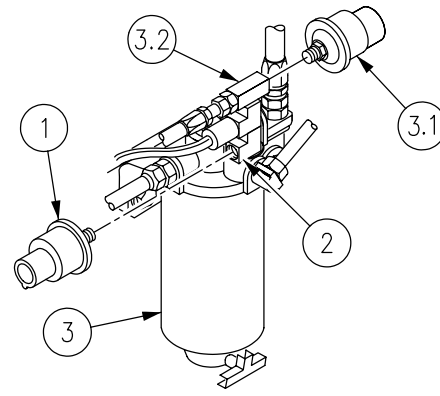

NEW CONFIGURATION



57. Remove ten self-locking bolts (7) and ten washers (6) mating engine to transmission. Discard self-locking bolts.
58. Remove screw (3), two washers (4), and locknut (5) from engine. Discard locknut.
59. Remove locknut (2) and washer (1) from engine. Discard locknut.
60. Separate engine from transmission.

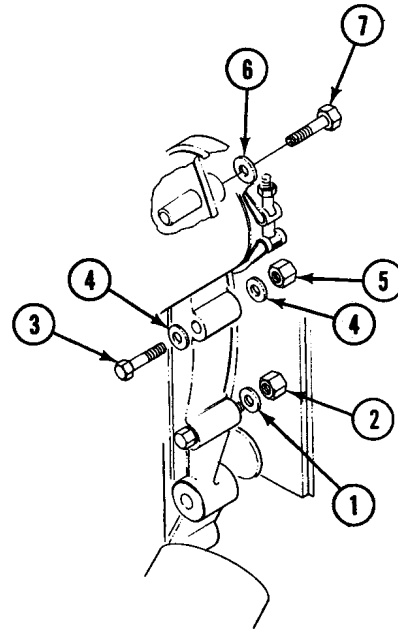
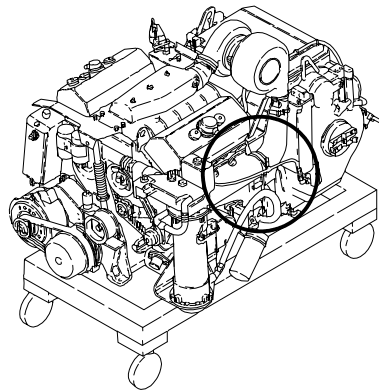

WARNING



Hydraulic fluid is poisonous and can be absorbed through your skin. Wash off any hydraulic fluid which contacts your skin. Read the hydraulic fluid warning in the front of this manual.

61. Disconnect three hoses (11) from elbows (12) on hydraulic pump (13).
62. Remove two screws (14), washers (15), hydraulic pump (13), and gasket (16) from engine adapter. Discard gasket.

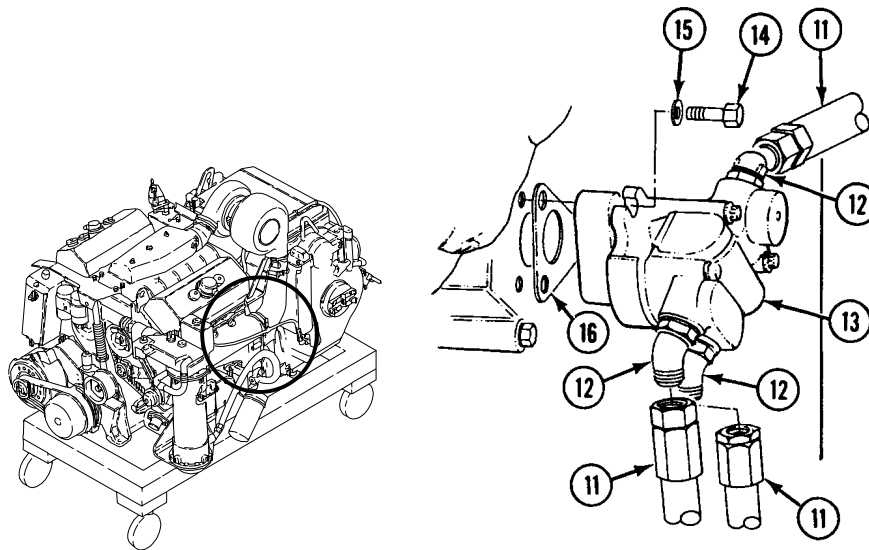

63. Remove four straps (15). Discard straps.

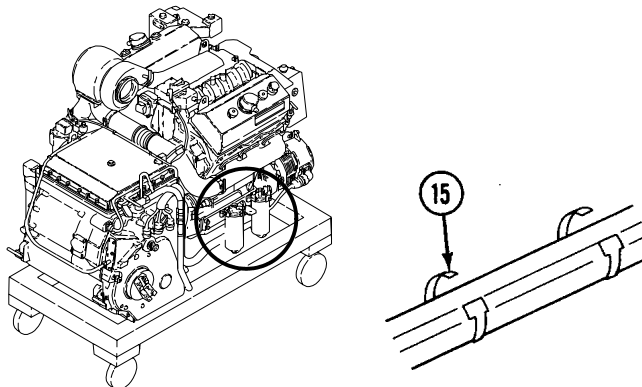

64. Disconnect ramp to tank hose (13) from elbow (14) on side of hydraulic tank (4). Remove hose.
65. Disconnect pump to tank hose (11) from tee (12) on side of hydraulic tank (4). Remove hose.
66. Disconnect pump to tank (strainer) hose (9) from elbow (10) on bottom of hydraulic tank (4).

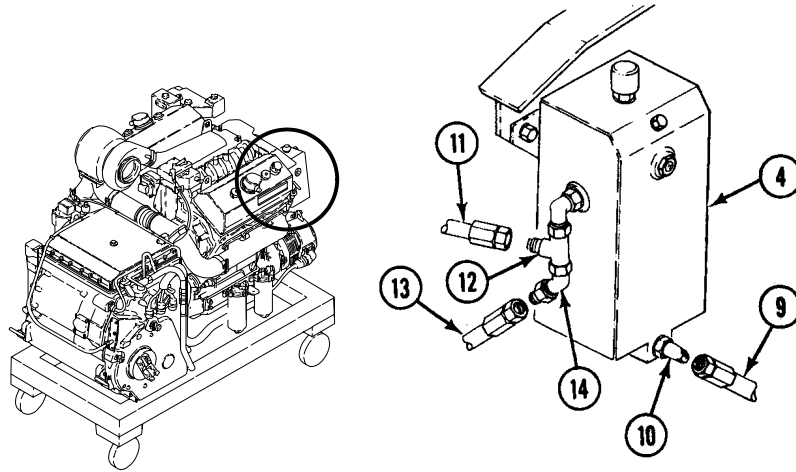

67. Remove three screws (6), six washers (7), and three locknuts (8) that secure tank (4) to brackets (3) and (5). Remove tank. Discard locknuts.
68. Remove screw (1), washer (2), and bracket (3) from engine. Install screw and washer on engine.

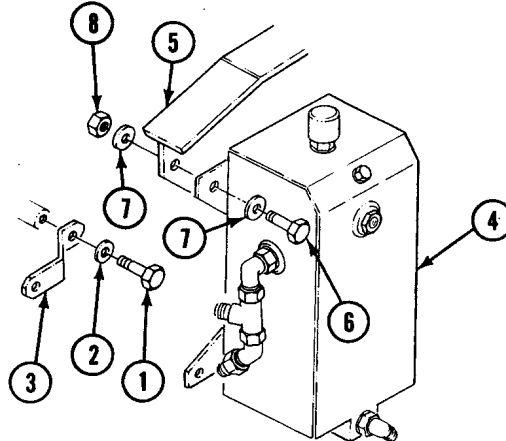

69. Remove screw (23), two washers (24), and nut (25) that secure lever assembly (22) to engine.

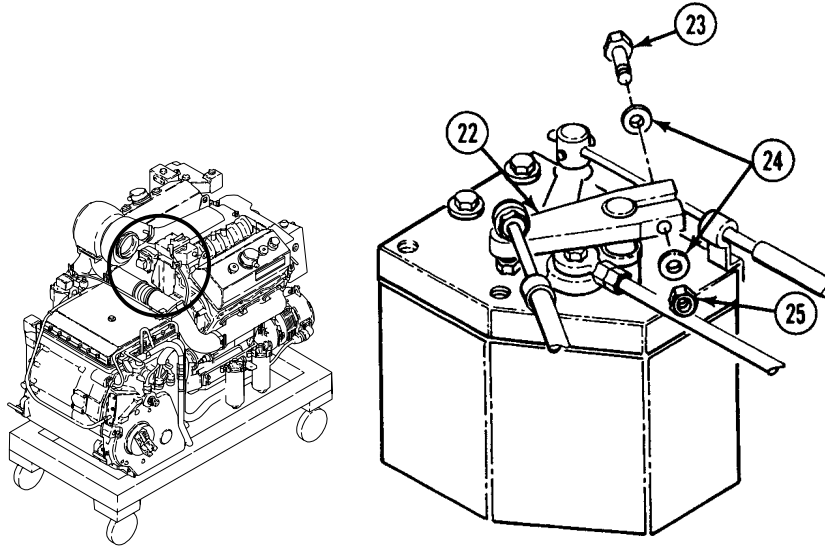

70. Remove screw (1) and washer (2).

71. Remove screw (3) and washer (4) and remove bracket (5).

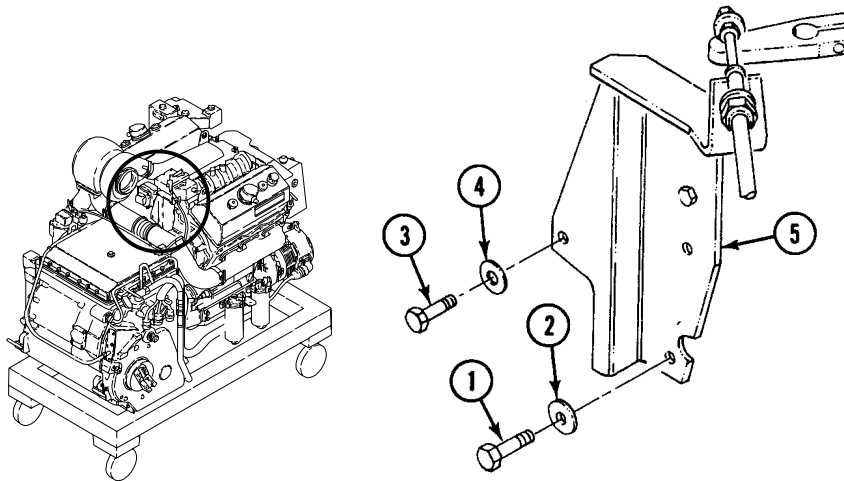

INSTALLATION

WARNING

Hydraulic fluid is poisonous and can be absorbed through your skin. Wash off any hydraulic fluid which contacts your skin. Read the hydraulic fluid warning in the front of this manual.

1. Install new hydraulic pump (6) and new gasket (7) on engine adapter. Secure with two screws (8) and washers (9). TIGHTEN SCREWS TO 25-30 LB-FT (34-41 N·m).

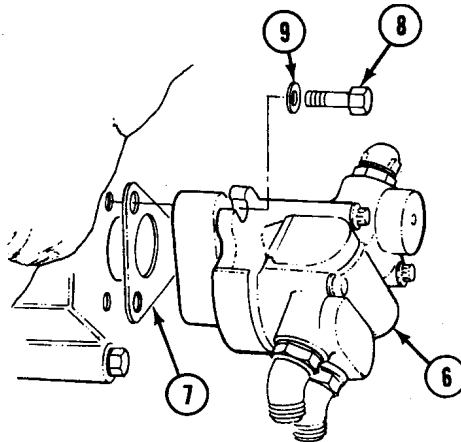

2. Remove new engine from shipping container and place new engine on engine and transmission stand. Use sling and lifting device.
3. Place and secure old engine in shipping container.

CAUTION

Damage to engine will result if crankshaft endplay is not complied with. Engines require a crankshaft endplay of not less than 0.004 inch (0.102 mm) nor more than 0.016 inch (0.406 mm) with new parts or 0.018 inch (0.457 mm) with used parts.

NOTE

The crankshaft endplay inspection must be completed without the transmission or front crankshaft pulley installed.

4. Measure crankshaft endplay.

- a. Clean transmission drive coupling (1) and engine flywheel spline (2). Apply antiseize compound.

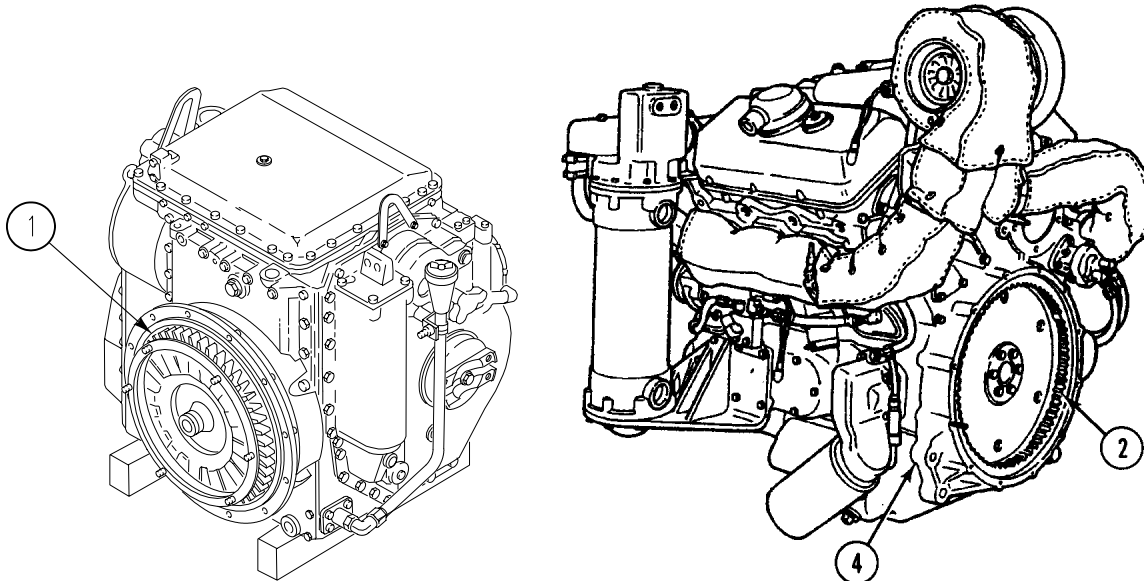

- b. Hit the front end of the crankshaft (3) two or three times with a large plastic mallet, driving the crankshaft towards the rear or flywheel-housing end of engine. Striking the crankshaft will reduce the oil film on the thrust washers and provide a more accurate reading.
- c. Apply constant pressure on the crankshaft (3) towards the rear engine mount.

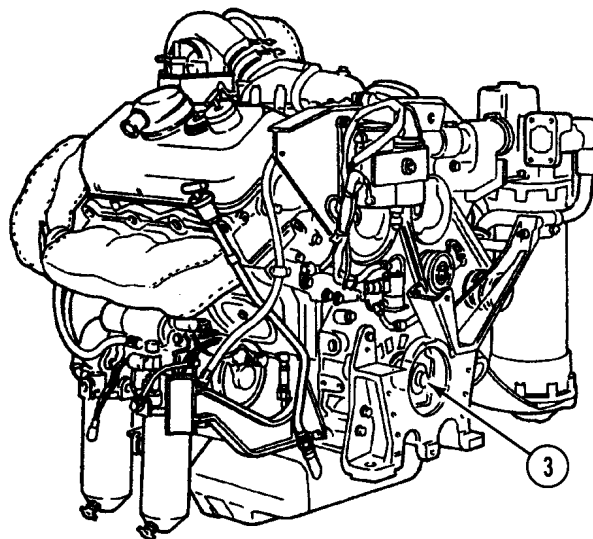

- d. Position a magnetic base dial indicator (4) on the front bracket (3) with dial indicator plunger (1) on crankshaft nut (5) and zero adjust dial indicator (2).

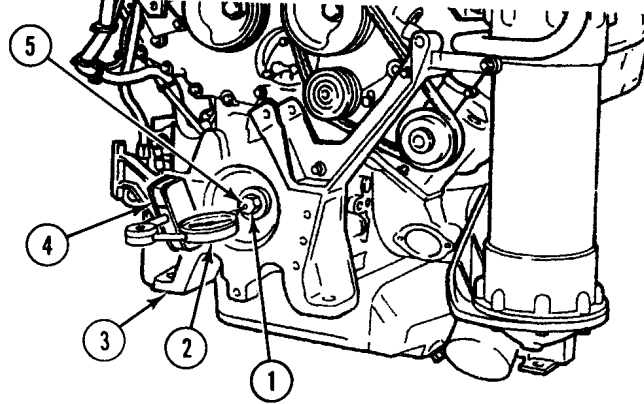

- e. Position small (length less than 12 inches (30.5 cm)) pry bar (1) between front crankshaft washer (3) and front bracket (5). Pull crankshaft (4) towards front of engine, maintain constant pressure, and record crankshaft endplay as read from indicator dial (5).

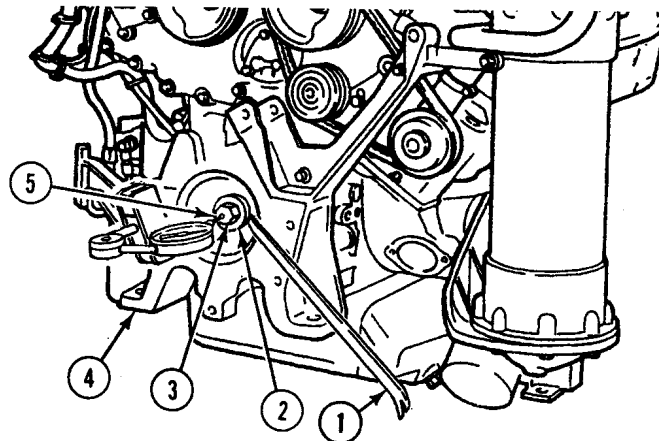

NOTE

There are two sets of index splines located on the engine flywheel and transmission drive coupling, 180 degrees apart.

Transmission drive coupling may be rotated with a screw driver to align index splines for assembly. Do not use fingers.

5. Rotate transmission drive coupling (10) to align with engine flywheel indexing spline (11).

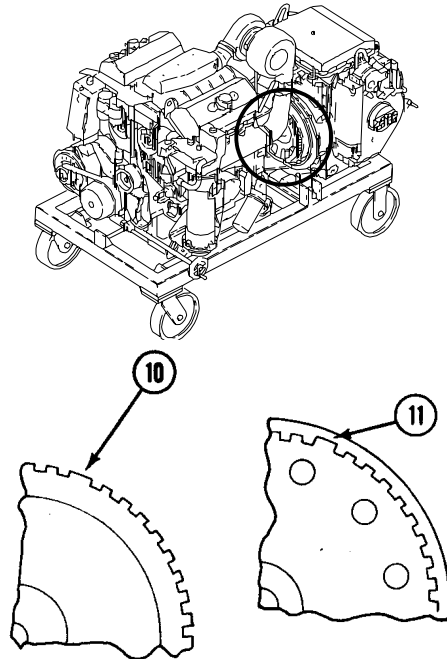

6. Using engine and transmission stand, adjust transmission to align with engine. With proper alignment, mate engine to transmission.

NOTE

Do not torque engine to transmission attaching screws and nuts until all twelve screws have been seated.

7. Install washer (1) and new locknut (2). TORQUE LOCKNUT TO 25-27 LB-FT (34-37 N·m).
8. Install screw (3), two washers (4), and new locknut (5). TORQUE LOCKNUT TO 25-27 LB-FT (34-37 N·m).

9. Install ten washers (6) and new self-locking bolts (7). TORQUE BOLTS TO 38-41 LB-FT (52-56 N·m).

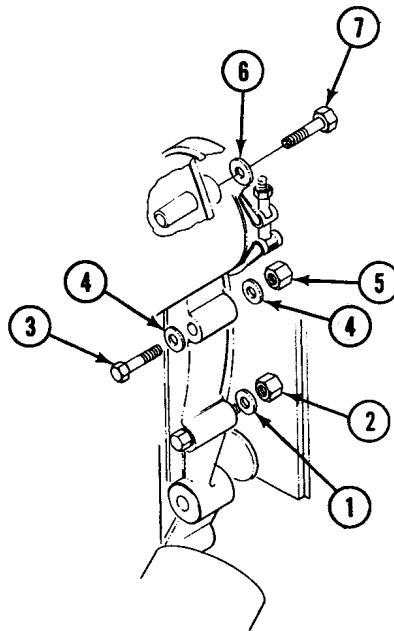

CAUTION

Damage to engine will result if crankshaft endplay is not complied with. Engines require a crankshaft endplay of not less than 0.004 inch (0.102 mm) nor more than 0.016 inch (0.406 mm) with new parts or 0.018 inch (0.457 mm) with used parts.

NOTE

The crankshaft endplay inspection must be completed without the front crankshaft pulley installed.

10. After transmission is mounted to engine, repeat Step 4 and record crankshaft endplay reading.

NOTE

If the second crankshaft endplay reading has changed, there is binding or misalignment between the engine and transmission.

11. Compare crankshaft endplay readings from before and after mounting transmission. Before and after crankshaft endplay readings should not be different.
12. If the readings are different, remove transmission mounting bolts and pull transmission away from engine Steps 57 - 60.
13. Reinstall transmission to engine Steps 5 - 9 ensuring correct alignment of crankshaft and flywheel housing.
14. Recheck crankshaft endplay Step 4 and Step 10.

15. Connect three hoses (11) to elbows (12) on hydraulic pump (13).

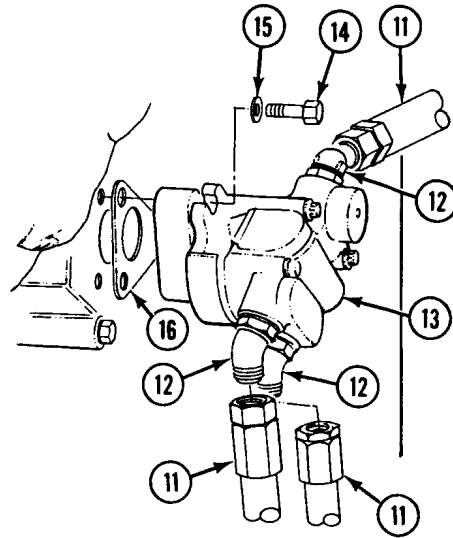

16. Secure two hoses (8) and (9) with two new straps (15).

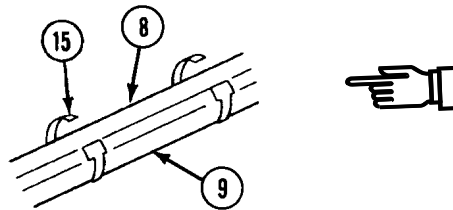

17. Remove screw (1) and washer (2) from engine.
 18. Install bracket (3), screw (1), and washer (2) on engine.
 19. Install tank (4) and secure to brackets (5) and (3) with three screws (6), six washers (7), and three new locknuts (8).
 TORQUE SCREW (1) ON ENGINE TO 27-32 LB-FT (37-43 N·m).

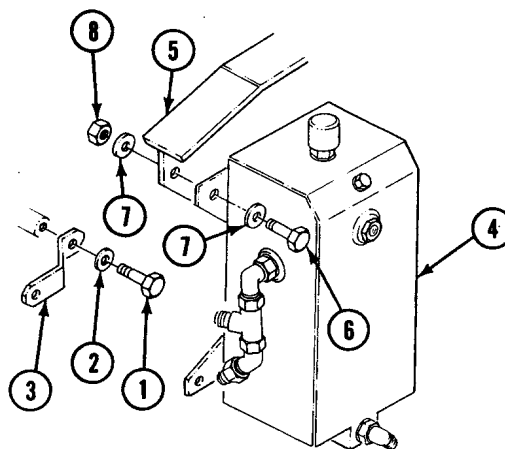

20. Connect pump to tank (strainer) hose (9) to elbow (10) on hydraulic tank (4).
 21. Connect pump to tank hose (11) to tee (12) on hydraulic tank (4).

22. Connect ramp to tank hose (13) to elbow (14) on hydraulic tank (4).

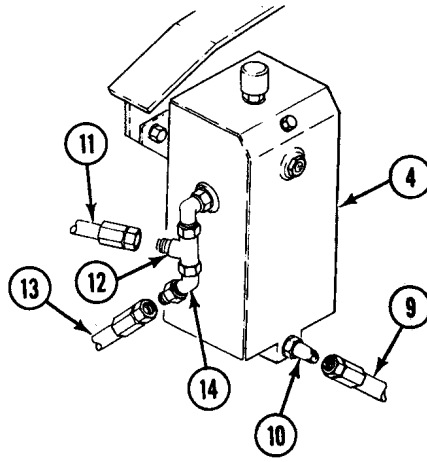

23. Secure two hoses (11) and (13) with four new straps (15).

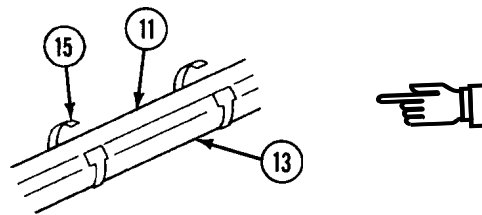

NOTE

Do not tighten generator mounting bracket screws until all the mounting screws have been installed. All three screws require a specific torque.

24. Position generator mounting bracket (16) and install washer (17) and screw (18). TORQUE SCREW TO 32-34 LB-FT (43-46 N·m).
25. Align generator mounting bracket (16) holes. Install washer (19) and screw (20). TORQUE SCREW TO 36-38 LB-FT (49-52 N·m).
26. Align generator mounting bracket (16) holes. Install washer (21) and screw (22). TORQUE SCREW TO 32-34 LB-FT (43-46 N·m).

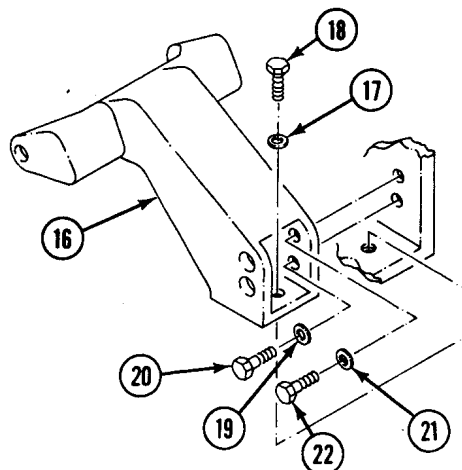

27. Install generator (4) on bracket (5). Secure with two screws (1), new locknuts (2), and three washers (3).

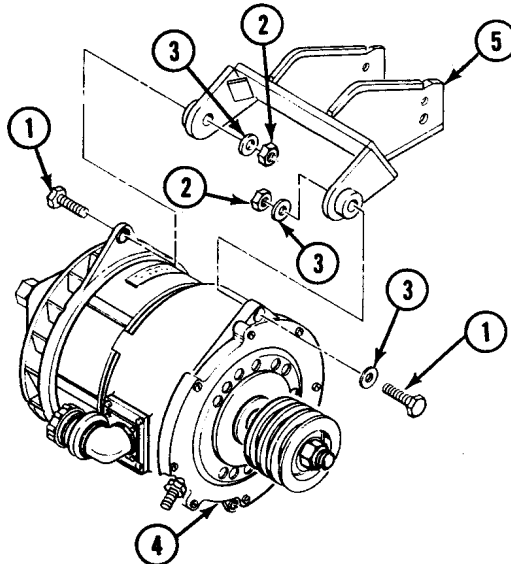

28. Install screw (6), two washers (7), spacer (8), and turnbuckle (9) on generator (1).

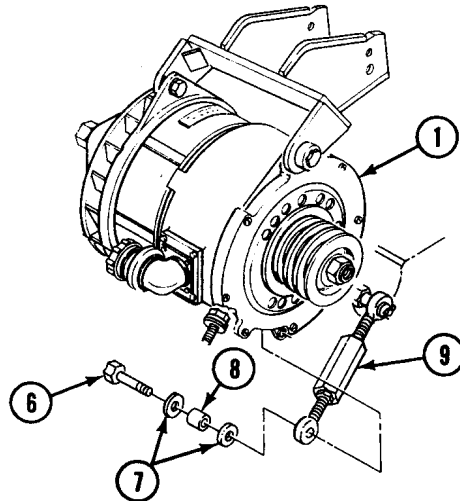

29. □ Install generator field switch (1) on tee (2) and secondary fuel filter (3) (old configuration).

30. □ Install switch (3.1) on tee (3.2) (new configuration).

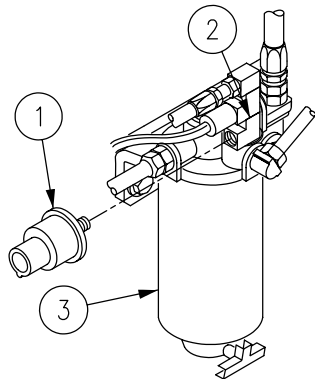

OLD CONFIGURATION

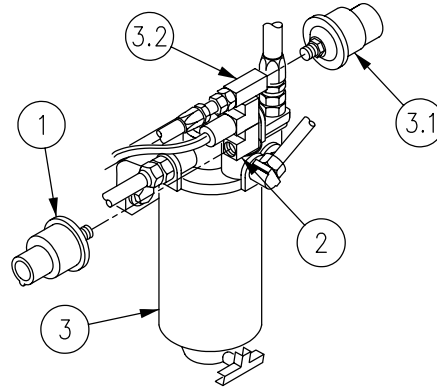

NEW CONFIGURATION



31. Install starter relay switch (13) on bracket (14) with two screws (15), washers (16), and new locknuts (17).

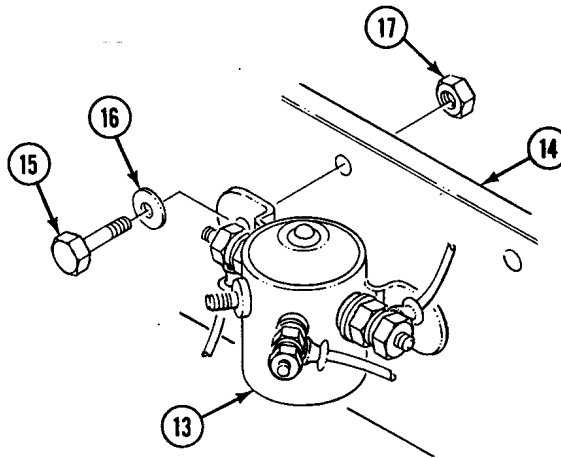

32. Install circuit leads 74D (18), 74C (19), and 74A (20) to solenoid battery terminals (21) and (22) and starter (23) with three nuts (24) and new lockwashers (25).

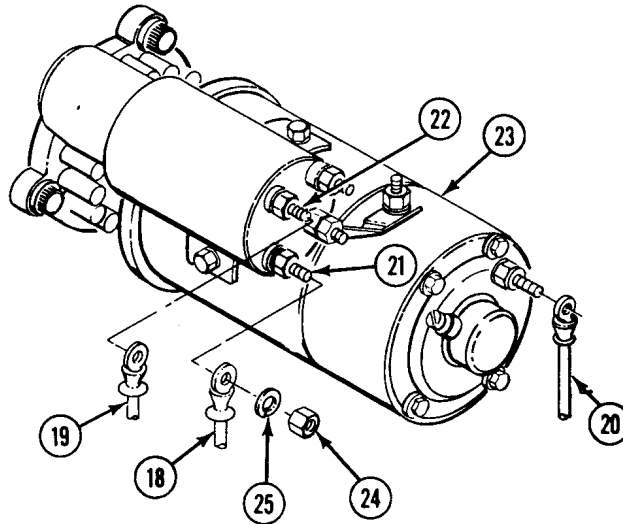

33. Install bracket (1) with screw (2) and washer (3) on engine. TIGHTEN SCREW TO 30-35 LB-FT (41-48 N·m) TORQUE.
34. Position oil sample valve (4) on bracket (5) and secure with jam nut (6).
35. Install elbow (7) and nipple (8) on engine.
36. Install low oil pressure switch (9), tee (10) and two adapters (11) and (12) on elbow (7).
37. Install clamp (13) on low oil pressure switch (9) and secure to bracket (1) with two washers (14), nut (15), and screw (16).
38. Connect hose (17) to adapter (18) on oil sample valve (4) and to adapter (12) on tee (10).

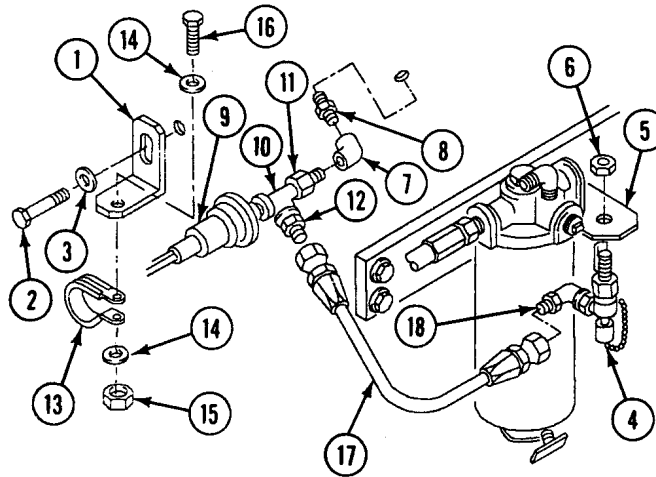

39. Install elbow (8) on primary fuel filter (9).

40. Connect fuel supply hose (7) to elbow (8).

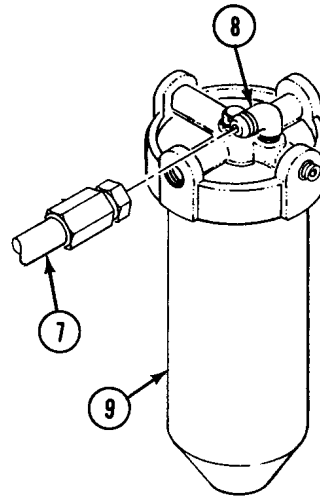

41. Connect fuel return hose (5) to elbow (6) on engine.

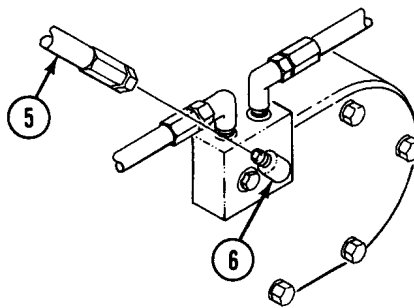

42. Install bracket (14) with screw (15) and two washers (16).

43. Secure transmission oil drain tube (17) on bracket (14) with clamp (13), screw (11), two washers (12), and new locknut (10).

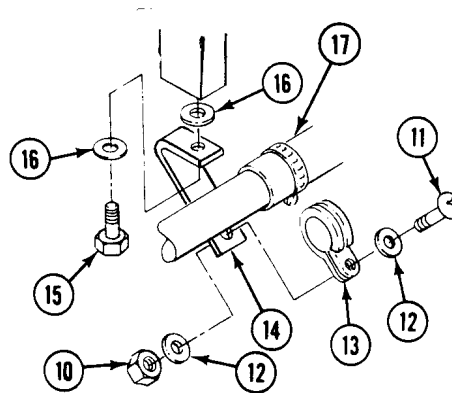

44. Install bracket (4), two screws (1), four washers (2), and two nuts (3) on engine.

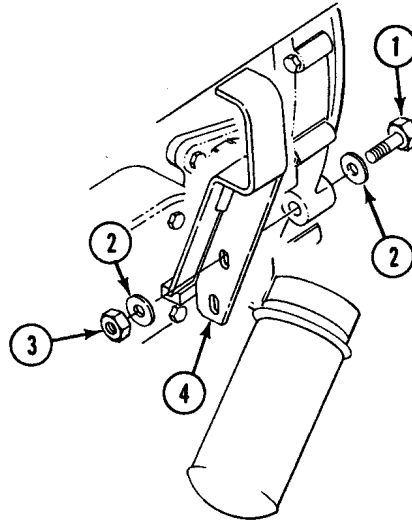

45. Install tee assembly (6) on oil cooler (7).
 46. Install elbow (5) on tee assembly (6).
 47. Install oil outlet hose (4) to elbow (5).

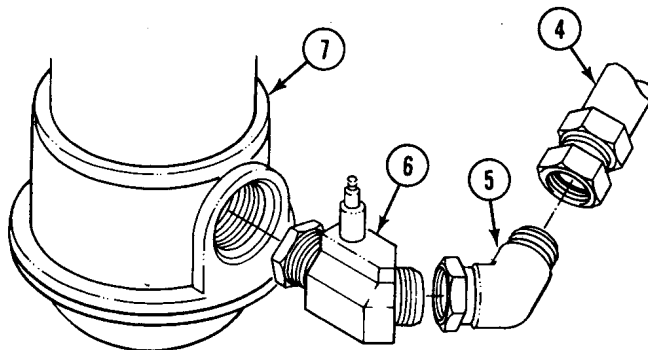

48. Install elbow assembly (8) on oil cooler (7).

49. Install oil inlet hose (9) on elbow assembly (8).

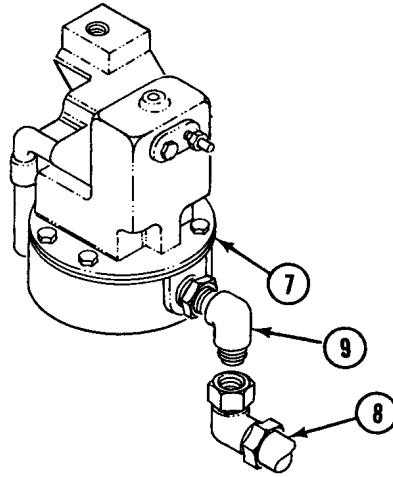

50. Install variable speed drive adapter (WP 0016 00).

51. Install fan and variable speed drive assembly (3) with six screws (1) and washers (2). Have helper assist.

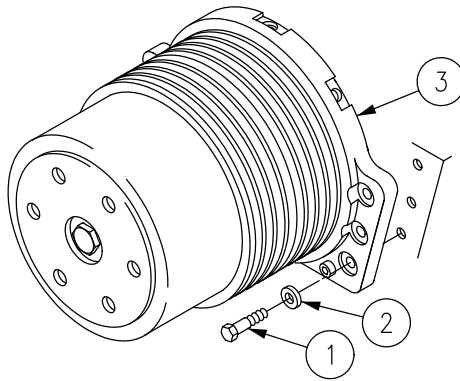

OLD CONFIGURATION

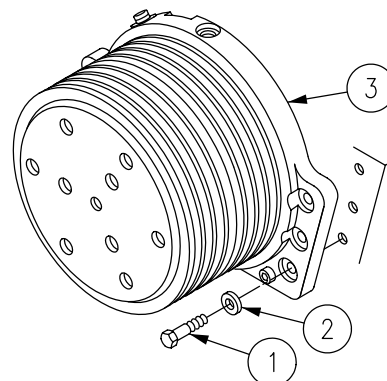

NEW CONFIGURATION



52. Install bracket (11) with hoses (1), (12), and (13) to engine. Use existing screw (8), washer (9), and nut (10).

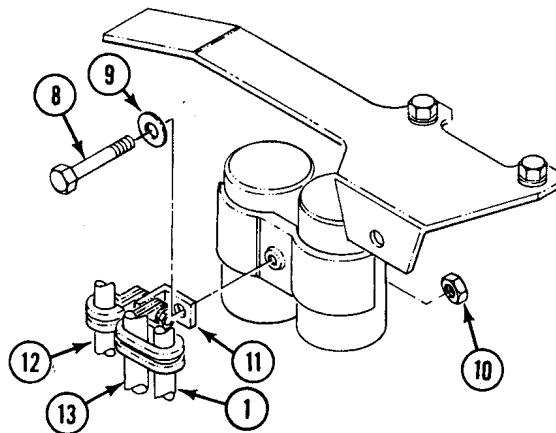

53. Install clamp (6) with hose (1) on transmission. Use existing screw (4), washer (5), and nut (7).

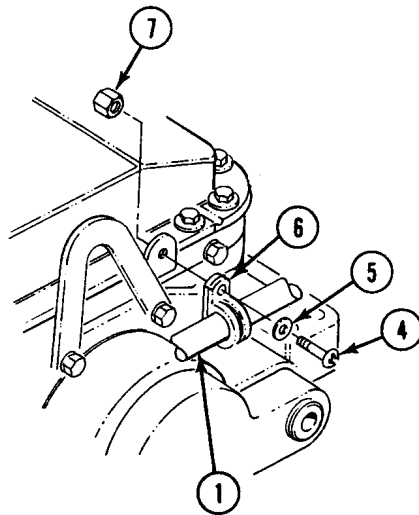

54. Connect hose (1) to elbow (2) on transmission end cover (3).

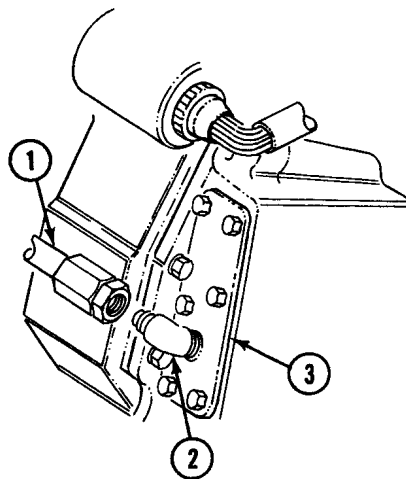

55. □ Install new preformed packing (17) and thermostatic switch (10) on power plant (old configuration).

56. □ Connect pressure hose (14) to adapter (16) on thermostatic switch (10) (old configuration). □

57. □ Install sensor (17.6) on thermostat housing (new configuration).

58. □ Install bracket assembly (17.5) and secure with two screws (7.3) and two lockwashers (17.4) (new configuration).

59. □ Install hose (17.1) on valve (17.2) (new configuration).

60. Connect lube port hose (13) to adapter (15) on thermostatic switch (10) (old configuration).

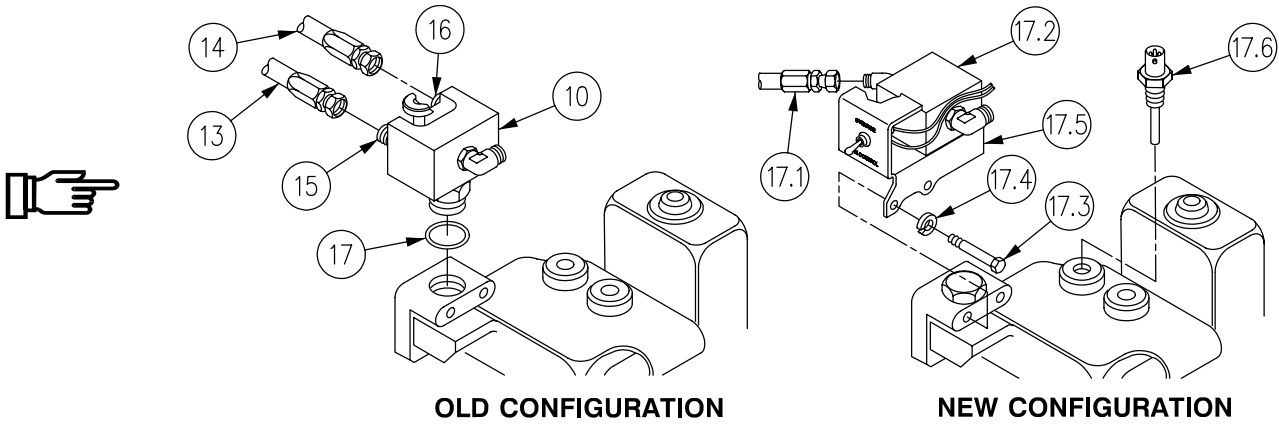

61. Connect return hose (1) to elbow (2) (old configuration) or adapter (7.1) (new configuration) on variable speed drive assembly (3).

62. Connect pressure hose (4) to elbow (5) on variable speed drive assembly (3) (old configuration).

63. Connect lube port hose (6) to elbow (7) on variable speed drive assembly (3).

64. Install tiedown strap (8) on hoses from variable speed drive.

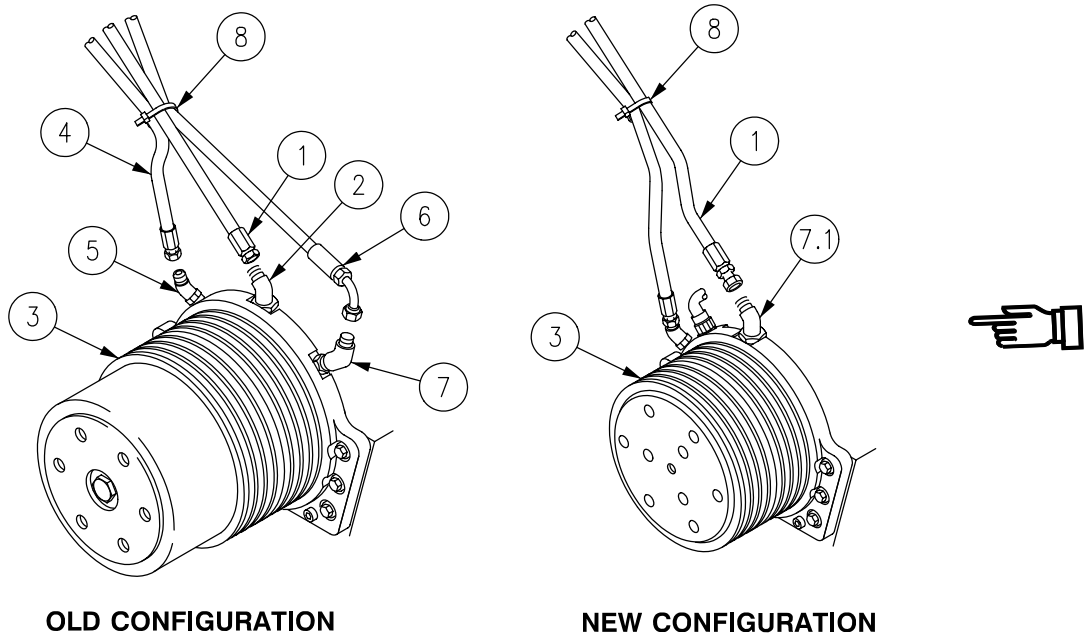

65. Connect supply hose (9) to elbow (10) on thermostatic switch (11) (old configuration) or valve (10.1) (new configuration).

66. Connect supply hose (9) to elbow (12) on transmission.

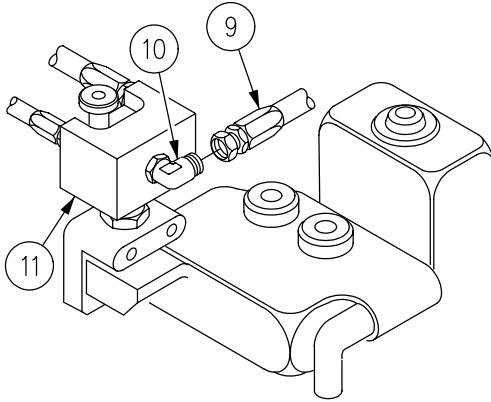

OLD CONFIGURATION

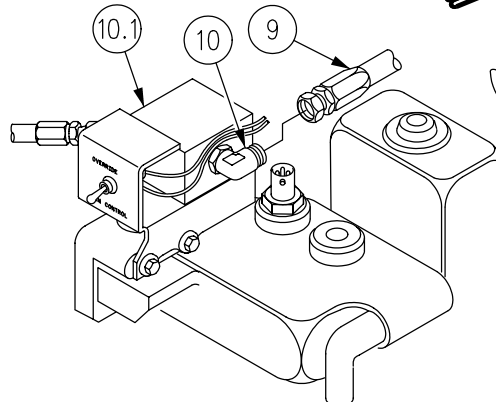

NEW CONFIGURATION

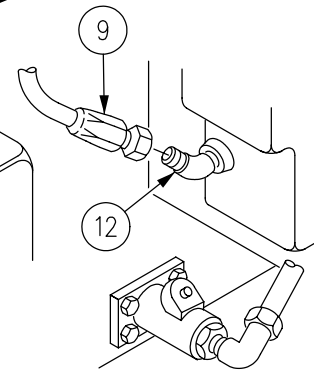

67. Install pulley (13) with bolt (14), washer (15), and new locknut (16).

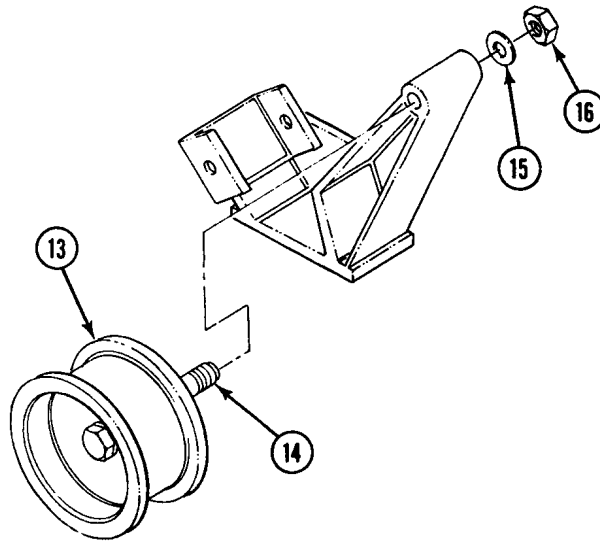

68. Position spring tensioner (1) with idler arm (2) and pulley (3) on bracket (4) and install cotter pin (5) and pin (6).
69. Position idler arm (2) and install screw (7), washer (8), and new locknut (9).

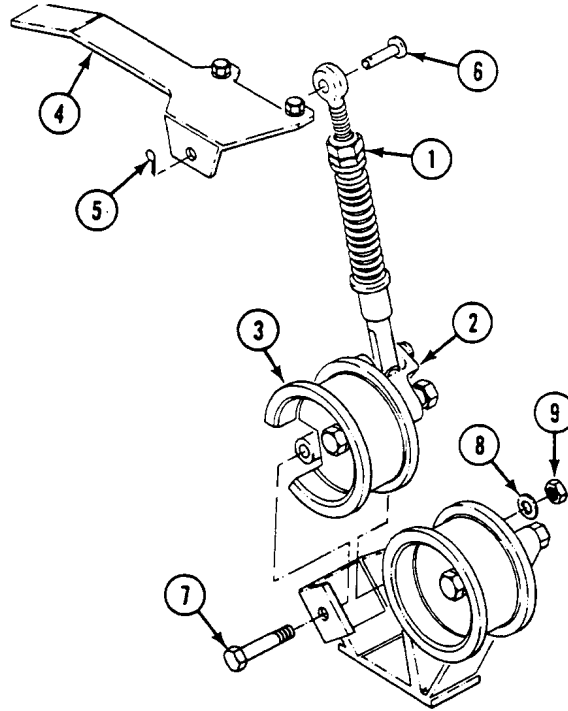

70. Install two screws (10), four washers (11), two washers (12), four mounts (13), two blocks (14), two washers (15), and two locknuts (16) on engine. TORQUE TO 100-120 LB-FT (136-163 N·m).

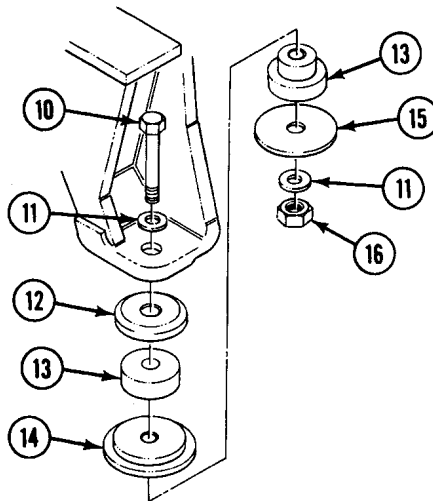

71. Install bracket (5) with screw (1) and washer (2), and with existing screw (3) and washer (4).

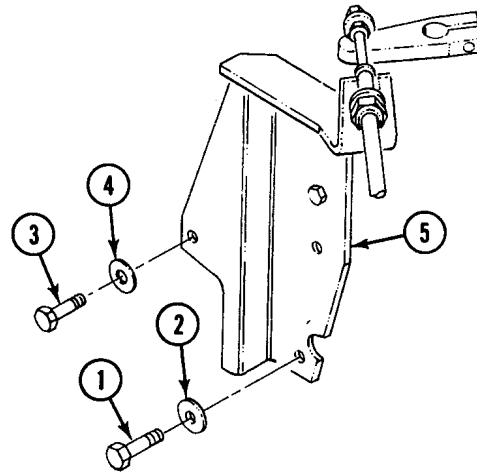

72. Position lever (22) and secure with screw (23), two washers (24), and nut (25).

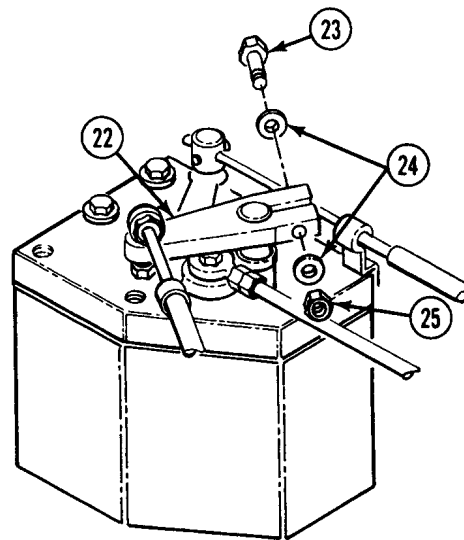

73. Connect harness lead (1) to pulse tachometer (2).

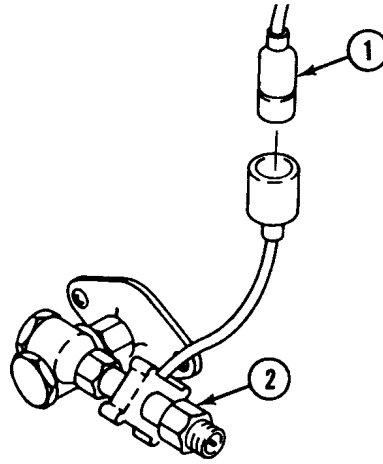

74. Connect lead (3) to fuel return pressure switch (4).

75. Connect lead (5) to turbo outlet pressure switch (6).

CAUTION

Excess heat can cause the fuel return pressure switch to leak. Leaking fuel can catch fire and cause equipment damage. Make sure electrical lead is secured away from exhaust duct.

76. Secure new tie strap (7).

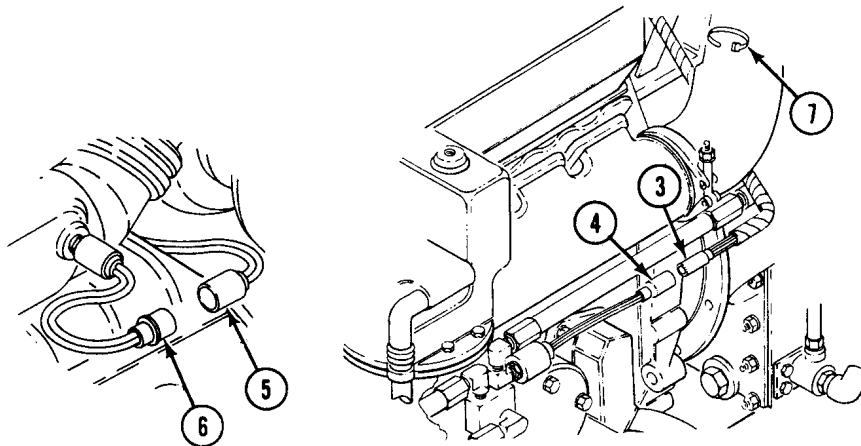

77. Install leads (8) on starter solenoid (9) terminals. Secure with two nuts (10) and new lockwashers (11).

78. Install leads (12) on starter (13) terminal. Secure with nut (14) and new lockwasher (15).

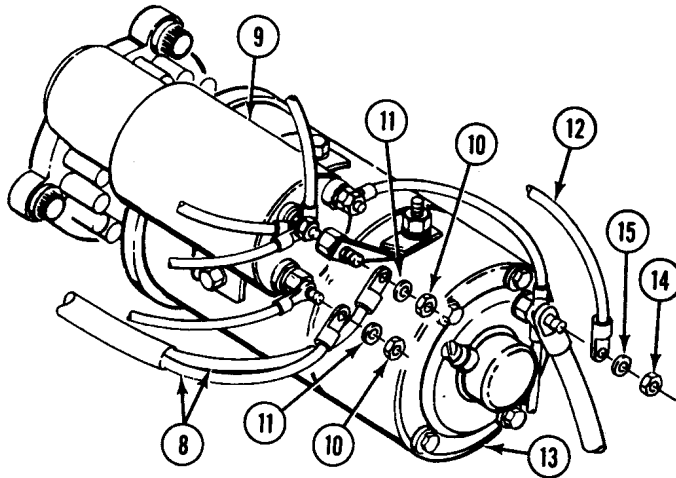

79. Connect lead (16) to fuel filter differential pressure switch (17).

80. Connect lead (18) to fuel supply pressure transducer (19).

81. Secure harness to engine with two new tie straps (20).

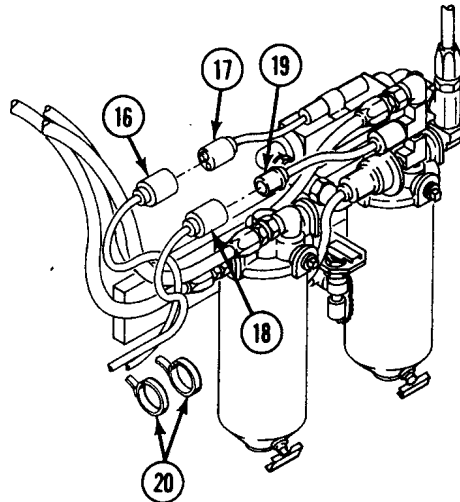

82. Connect lead (1) to airbox pressure transducer (2).

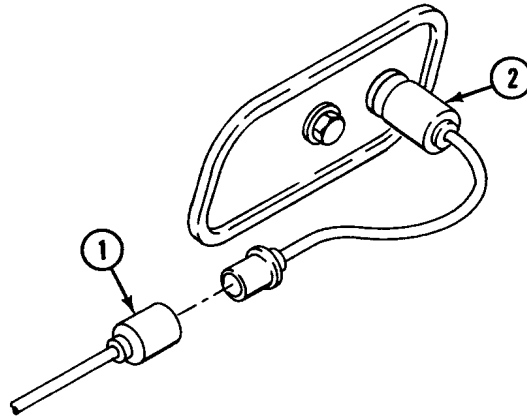

83. Connect leads (3) to generator main cable (4).

84. Install ground lead (5) and circuit lead (6) on generator (7). Secure with nut (8) and new lockwasher (9).

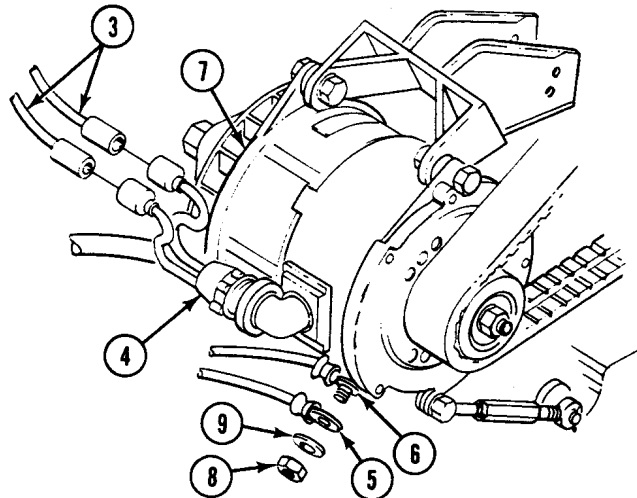

FOLLOW-THROUGH STEPS

1. Install variable speed fan drive wiring harness, 3W1 (see your -20) (new configuration).
2. Install engine wiring harness (see your -20).
3. Install power plant in carrier (see your -20).
4. Fill engine with oil (see your -20).
5. Fill hydraulic tank (see your -20).

END OF TASK

REPLACE VARIABLE SPEED DRIVE ASSEMBLY ADAPTER

0016 00

THIS WORK PACKAGE COVERS:

Removal (page 0016 00-1).
 Installation (page 0016 00-4).

INITIAL SETUP:

Maintenance Level

Direct Support

Tools and Special Tools

General Mechanic's Tool Kit (WP 0120 00, Item 62)
 Retaining Ring Pliers (WP 0120 00, Item 39)
 Puller Set (WP 0120 00, Item 45)
 Screws 1/4-28 UNF (3) (WP 0120 00, Item 49)
 Washer (3) (WP 0120 00, Item 67)
 Torque Wrench (WP 0120 00, Item 76)
 Socket Wrench Set (WP 0120 00, Item 78)

Materials/Parts

Grease (WP 0122 00, Item 20)
 Sealing compound (WP 0122 00, Item 27)
 Cotter pin
 Preformed packing (2)
 Preformed packing (2)

Personnel Required

Track Vehicle Repairer 63H10
 Helper

Equipment Condition

Variable speed drive assembly removed (see your -20)

REMOVAL

NOTE

Front hub assembly may come out when variable speed drive assembly is removed from engine or it may remain in engine. Go to Step 2 if front hub comes out with variable speed drive assembly.

1. Remove front hub (1) from sleeve (2) in engine.
2. Remove plug (3) from sleeve (2).

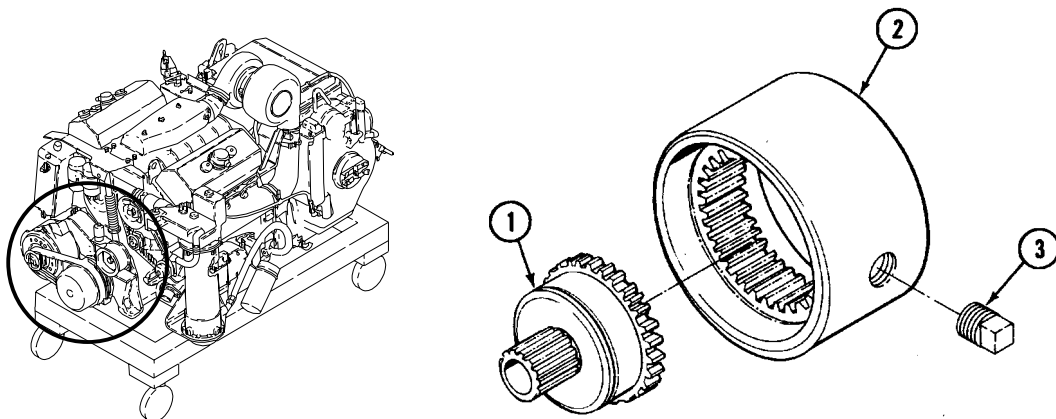

3. Remove snap ring (4) from front hub (1). Remove holder (5) and discard preformed packings (6)(7).

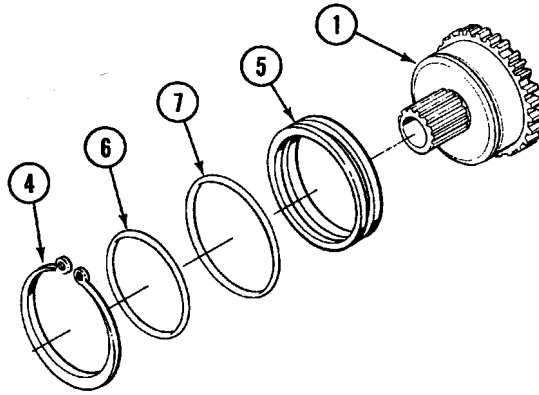

4. Remove cotter pin (1) and pin (2) from bracket (3). Discard cotter pin.

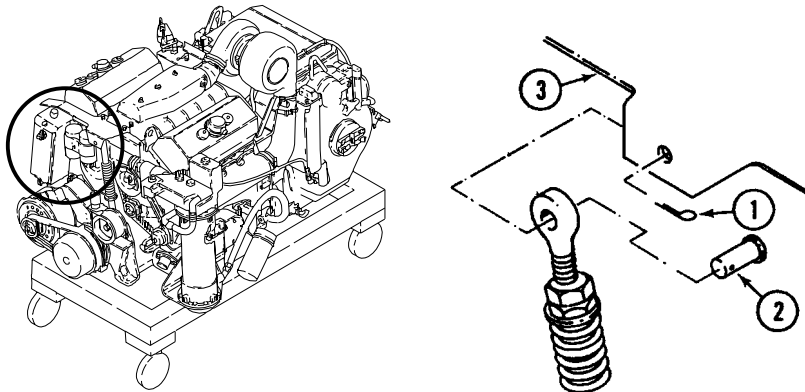

WARNING

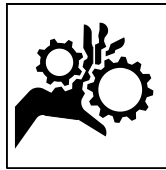

Engine could start and injure you. Stay clear of possible moving parts.

NOTE

Ensure FUEL SHUTOFF handle is in OFF position. Engine could start during performance of Step 6.

5. Have helper use 1 1/2 socket and 3/4 inch drive breaker bar on cam nut (1) to prevent engine from turning over in Step 6.

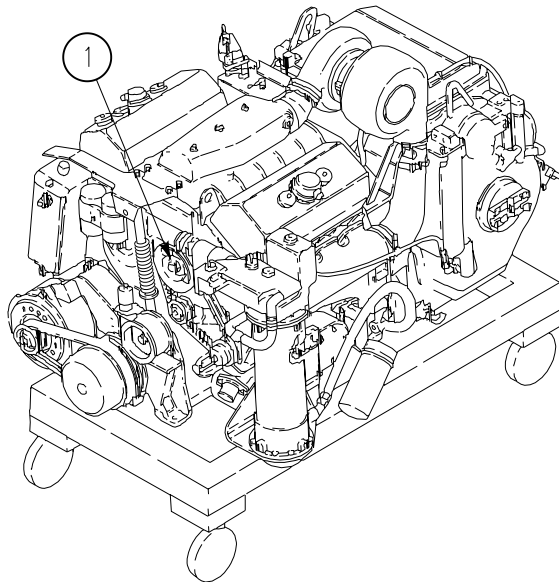

6. Loosen retainer screw (5) four complete turns. Use 3/4 inch drive breaker bar. Install puller and three 1/4-28 UNF screws. Install three screws and washers into rear hub (6). Break loose front cone (7) from seated position. Remove puller and three screws. Unscrew retainer screw (5), remove washer (8), and front cone (7).

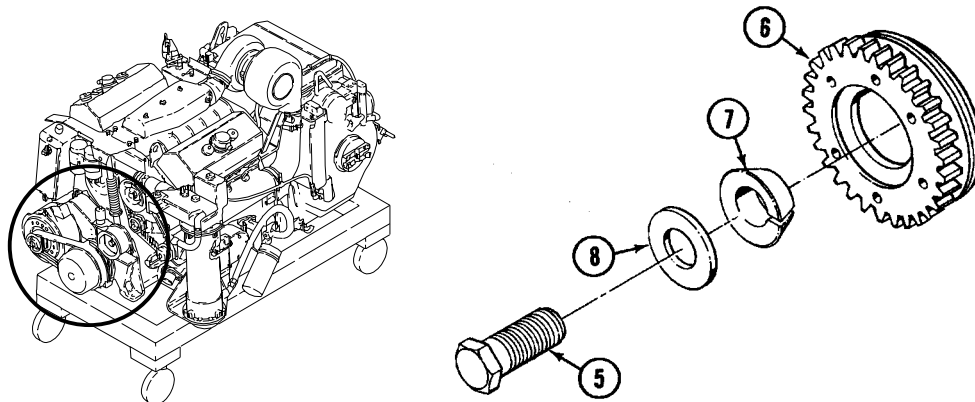

7. Remove rear hub (9) from sleeve (10).

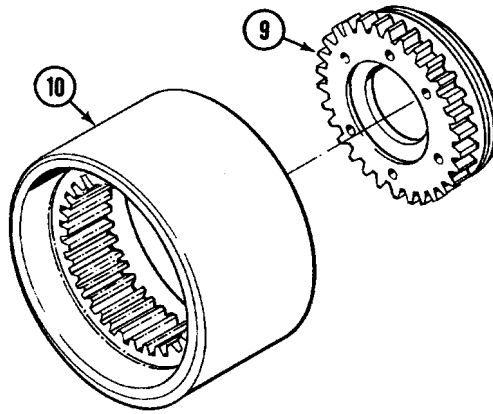

8. Remove snap ring (11) and holder (12) from rear hub (9). Remove preformed packings (13) and (14). Discard preformed packings.

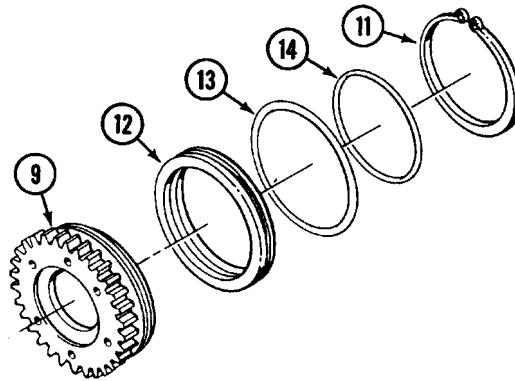

INSTALLATION

1. Install new preformed packings (14) and (13) on rear holder (12).
2. Install holder (12) and snap ring (11) on rear hub (9). Lubricate splines.

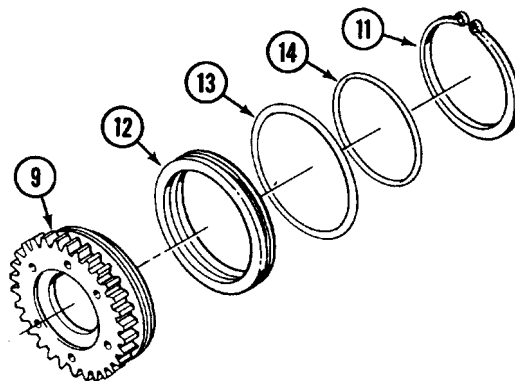

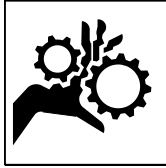
WARNING

Engine could start and injure you. Stay clear of possible moving parts.

NOTE

Ensure FUEL SHUTOFF handle is in OFF position. Engine could start during performance of Step 5.

3. Have helper use 1 1/2 socket and 3/4 inch drive breaker bar on cam nut (1) to prevent engine from turning over in Step 5.
4. Install rear hub (7) on engine crank shaft (8).
5. Install front cone (9), washer (10), and screw (11). **TIGHTEN SCREW TO 290-300 LB-FT (33-34 N·m) TORQUE.**
6. Install sleeve (12) on rear hub (7).

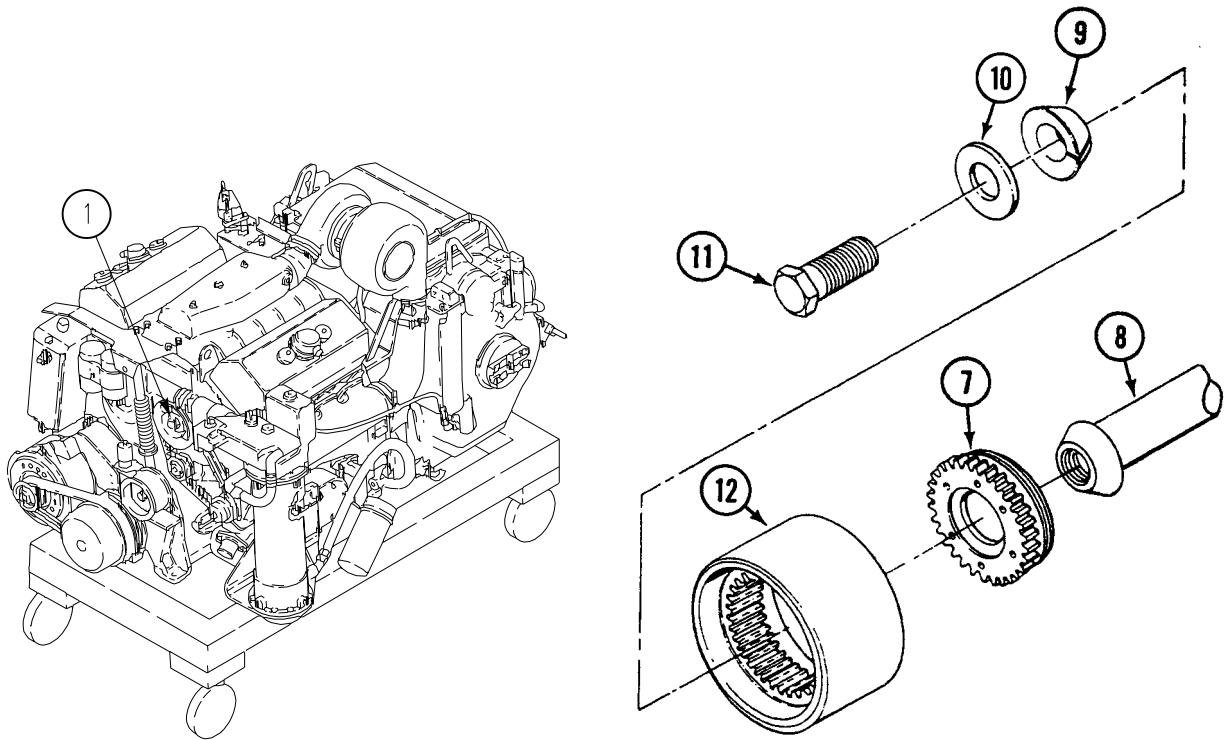

7. Install new cotter pin (1) and pin (2) to bracket (3). Have helper assist.

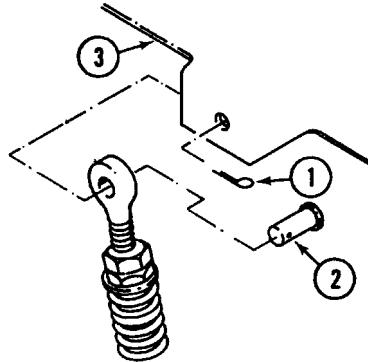

8. Apply sealing compound to plug (1).
9. Install plug (1) on sleeve (2).

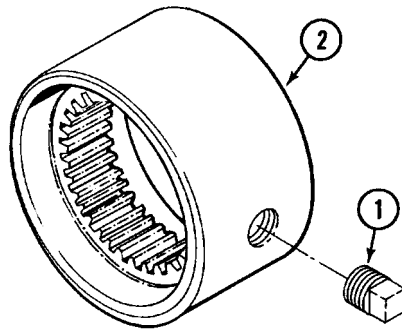

10. Install new preformed packings (3) and (4) on front holder (5).
11. Install holder (5) on front hub (6).
12. Install snap ring (7) on front hub (6).
13. Install front hub (6) on sleeve (8). Lubricate splines. Seat outer gear tightly in sleeve.

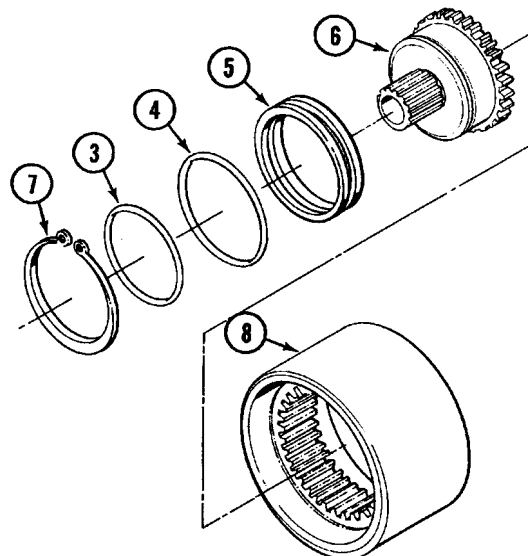

FOLLOW-THROUGH STEPS

1. Install variable speed drive assembly (see your -20).

END OF TASK

CHAPTER 4

DIRECT SUPPORT MAINTENANCE INSTRUCTIONS
FOR FUEL SYSTEM

WORK PACKAGE INDEX

<u>Title</u>	<u>Sequence No.</u>
REPAIR FUEL TANK (M577A3 AND M1068A3 ONLY).....	0017 00
REPAIR/REPLACE ACCELERATOR STOP SUPPORT ASSEMBLY.....	0018 00

REPAIR FUEL TANK (M577A3 AND M1068A3 ONLY)

0017 00

THIS WORK PACKAGE COVERS:

- Cleaning (page 0017 00-1).
- Repair or Replacement (page 0017 00-2).

INITIAL SETUP:

Maintenance Level

Direct Support

Tools and Special Tools

- Metal Worker's Tool Kit (WP 0120 00, Item 63)
- Trailer-Mounted Welding Shop (WP 0120 00, Item 69)

Materials/Parts

- Sealing compound (WP 0122 00, Item 28)
- Wiping rag (WP 0122 00, Item 36)

Personnel Required

Metal Worker 44B10

References

- See your -10
- See your -20
- TM 9-237

Equipment Condition

- Engine stopped (see your -10)
- Carrier blocked (see your -10)
- Ramp lowered (see your -10)
- Battery ground leads disconnected (see your -20)
- Fuel tank removed (see your -20)
- Fuel tank access cover removed (see your -20)
- Fuel quantity sending unit removed (see your -20)

CLEANING

WARNING



Fuel fumes can explode and burn you. Before welding: Drain all fuel. Disconnect and cap fuel and vent lines. Purge fuel residue and fumes by steam cleaning. Purge air from fuel tank with CO₂.

1. Use a wire brush to remove paint and dirt from outer surface area to be welded.

WARNING

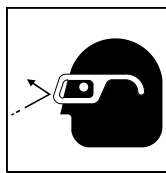

Air pressure in excess of 30 psi (207 kPa) can injure personnel. Do not direct pressurized air at yourself or others. Always wear goggles.

CAUTION

Do not expose seal areas to steam for more than 15 minutes, as existing seal will begin to deteriorate.

2. Steam clean inside of fuel tank (1). Use clean rags and 30 psi (207 kPa) compressed air to dry.

3. Direct carbon dioxide or argon gas into fuel tank (1) at 30-60 cubic feet (0.84-1.68 cubic meters) per hour until gas escapes from access cover openings.

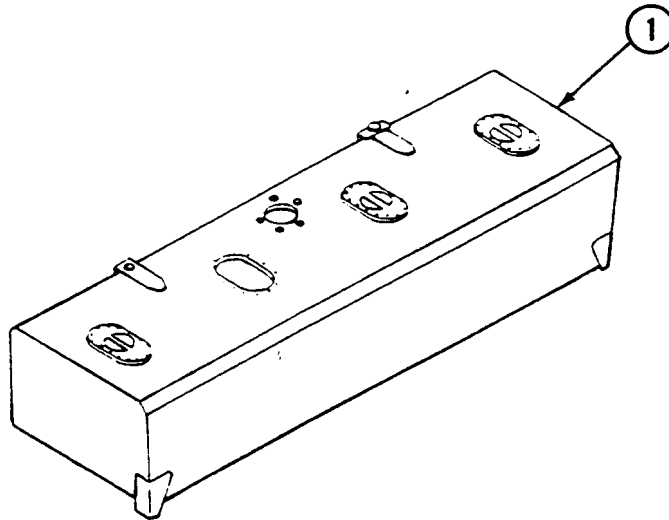

REPAIR OR REPLACEMENT

1. Plan to weld on outside of fuel tank, if possible.
2. Determine type of repair, overlapping or fitted patch.
3. Resize hole in fuel tank, to remove sharp edges or cracks, for type of patch selected.
4. Prepare a piece of aluminum of the same alloy and thickness as the fuel tank.
5. Size patch to cover hole in fuel tank.
6. Tack weld a small piece of aluminum upright to center of patch to hold patch for welding.
7. Weld patch to fuel tank. See TM 9-237 and see your -20.
8. Break support away from patch. Discard support.

9. Seal weld patch with sealing compound.

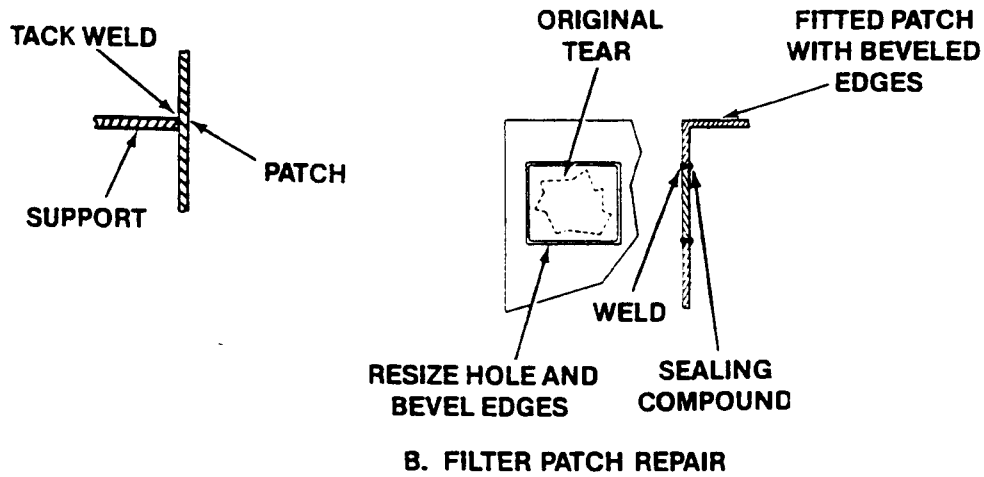
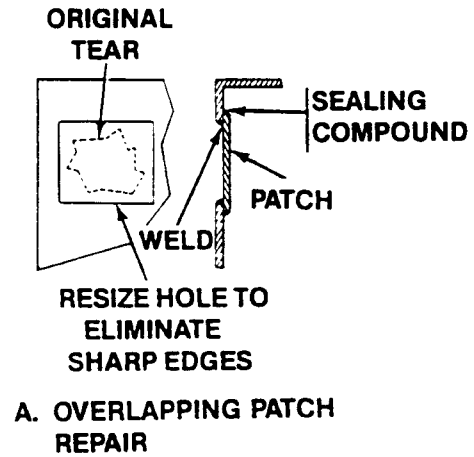

FOLLOW-THROUGH STEPS

1. Install fuel tank access cover (see your -20).
2. Install fuel tank (see your -20).
3. Fill fuel tank (see your -10). Check tank for leaks.
4. Connect battery ground leads (see your -20).
5. Start engine (see your -10).
6. Raise and lock ramp (see your -10).
7. Stop engine (see your -10).

END OF TASK

REPAIR/REPLACE ACCELERATOR STOP SUPPORT ASSEMBLY

0018 00

THIS WORK PACKAGE COVERS:

Removal (page 0018 00-1).
 Installation (page 0018 00-2).

INITIAL SETUP:

Maintenance Level

Direct Support

Tools and Special Tools

- Metal Worker's Tool Kit (WP 0120 00, Item 63)
- Trailer Mounted Welding Shop (WP 0120 00, Item 69)
- Sander Spindle Adapter (WP 0120 00, Item 1)
- Welder's Gloves (WP 0120 00, Item 18)
- Industrial Goggles (WP 0120 00, Item 19)
- Welder's Helmet (WP 0120 00, Item 21)
- Electric Disc Sander (WP 0120 00, Item 46)
- Arc Welding Machine (WP 0120 00, Item 68)

Materials/Parts

Welding electrode (WP 0122 00, Item 35)

Personnel Required

Metal Worker 44B10

References

- See your -10
- See your -20
- TM 9-237
- TM 43-0139

Equipment Condition

- Engine stopped (see your -10)
 - Carrier blocked (see your -10)
 - Ramp lowered (see your -10)
 - Battery ground strap disconnected (see your -20)
 - Driver's seat removed (see your -20)
 - Upper accelerator pedal removed (see your -20)
 - Lower accelerator pedal removed (see your -20)
 - Upper and lower service brake pedals removed (see your -20)
-

REMOVAL

1. Remove screw (1) and nut (2) from support assembly (3).

NOTE

To replace nut (5) only, go directly to Step 5.

2. Remove broken support assembly (3) from floor plate. Discard broken support assembly.

WARNING

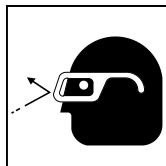

Metal chips and grinding dust can cause eye injury. Wear goggles and gloves.

3. Use a machinist's hammer and a cold chisel to chip off remaining part of bad support assembly from floor plate.
4. Use a disc sander to sand chipped area smooth and remove hard coating from weld area.

5. Use a machinist's hammer and a cold chisel to remove two rivets (4) securing nut (5) to support. Remove nut.

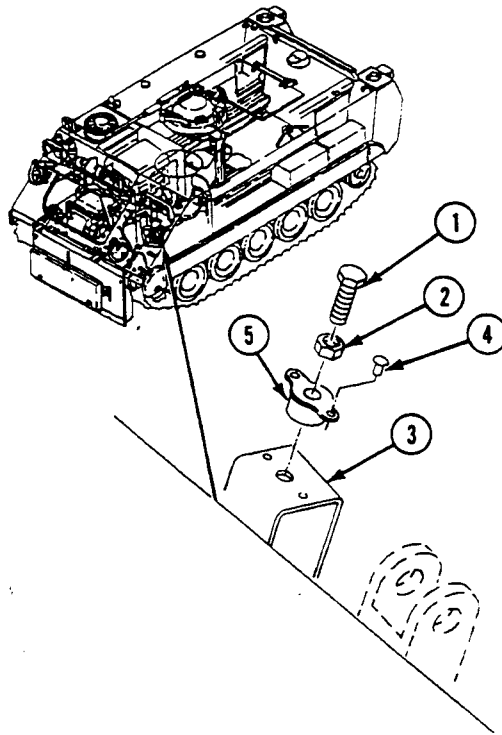

INSTALLATION

NOTE

To install nut (2) only, go directly to Step 4.

1. Position support assembly (1) on front bulkhead 4-11/16 inches (11.9 cm) from left edge of support to engine compartment bulkhead. Use straight edge to locate and scribe a line between mounting holes.

WARNING

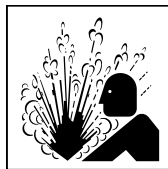

Unsafe welding practices can cause serious injury from fire, explosions, or harmful agents. Allow only authorized personnel to weld or cut metals, and follow safety precautions in TM 9-237. Protective clothing and goggles must be worn; adequate protective equipment used, a suitable fire extinguisher kept nearby; and requirements of TM 9-237 strictly followed.

NOTE

Read (WP 0004 00) before welding.

2. Weld support assembly (1) to floor plate, using dimensions shown, in accordance with TM 9-237. Use electrode type 5356.

3. Prepare and paint surface in accordance with TM 43-0139.
4. Position nut (2) on support (1). Secure with two rivets (3).
5. Install nut (4) and screw (5) into nut (2).

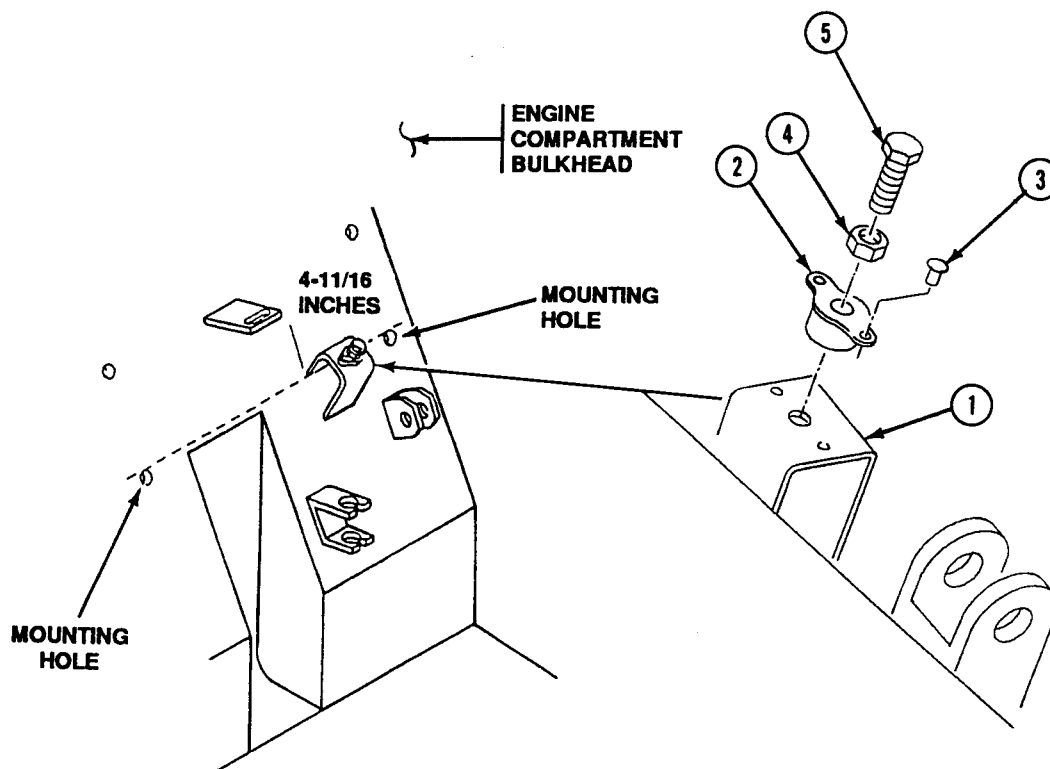

FOLLOW-THROUGH STEPS

1. Install upper accelerator pedal (see your -20).
2. Install driver's seat (see your -20).
3. Connect battery ground strap (see your -20).
4. Start engine (see your -10). Check that accelerator pedal works right.
5. Raise and lock ramp (see your -10).
6. Stop engine (see your -10).

END OF TASK

CHAPTER 5

DIRECT SUPPORT MAINTENANCE INSTRUCTIONS
FOR COOLING SYSTEM

WORK PACKAGE INDEX

<u>Title</u>	<u>Sequence No.</u>
REPAIR RADIATOR.....	.0019 00
REPAIR RADIATOR AUXILIARY TANK.....	.0020 00
REPAIR VENTILATING FAN ASSEMBLY.....	.0021 00
REPAIR FAN DRIVE SHAFT AND BEARING HOUSING.....	.0022 00

REPAIR RADIATOR

0019 00

THIS WORK PACKAGE COVERS:

- Testing radiator for flow (page 0019 00-1).
- Cleaning radiator (page 0019 00-2).
- Disassemble (page 0019 00-3).
- Inspection and Repair (page 0019 00-3).
- Rod (page 0019 00-4).
- Assemble (page 0019 00-4).

INITIAL SETUP:

Maintenance Level

Direct Support

Materials/Parts

- Soldering flux (WP 0122 00, Item 32)
- Tin alloy solder (WP 0122 00, Item 33)

Tools and Special Tools

- Metal Worker's Tool Kit (WP 0120 00, Item 63)
- Apron (WP 0120 00, Item 2)
- Scratch Wire Brush (WP 0120 00, Item 5)
- Radiator Flow Test Machine (WP 0120 00, Item 16)
- Industrial Goggles (WP 0120 00, Item 19)
- Radiator Test Plug Set (WP 0120 00, Item 41)
- Radiator Test Stand (WP 0120 00, Item 56)

Personnel Required

Metal Worker 44B10

References

See your -20
TM 750-254

Equipment Condition

Radiator removed (see your -20)

WARNING

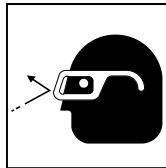

Air pressure in excess of 30 psi (207 kPa) can injure personnel. Do not direct pressurized air at yourself or others. Always wear goggles.

INSPECTION OF INSTALLED ITEMS

TESTING RADIATOR FOR FLOW

1. Plug auxiliary tank connector opening (1). Use radiator test plug set.
2. Plug radiator outlet opening (2) Use radiator test plug set.
3. Immerse radiator in water. Direct air at 25 to 30 psi (172 to 207 kPa) into inlet opening (3). Use radiator flow test machine.

4. If air bubbles appear, repair radiator.

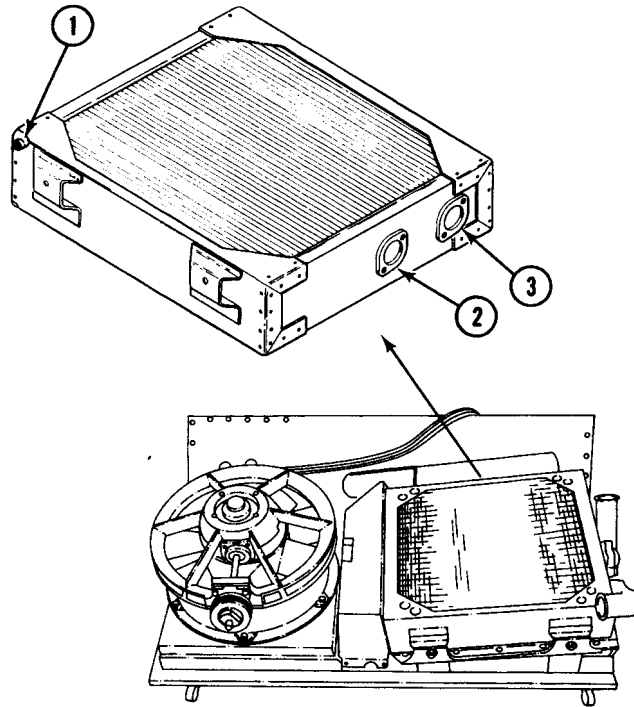

CLEANING RADIATOR

1. Clean radiator. See TM 750-254. Use safety goggles, rubber gloves, and rubber apron.
2. Thoroughly flush radiator. Use radiator test plug set. See TM 750-254.
3. Retest radiator for flow.
4. If water does not flow freely from inlet opening after cleaning, clean by rodding Step 4.

DISASSEMBLE

1. Heat, melt, and wire brush off the solder that secures two side brackets (1) and (2) to two end tanks (3) and (4).
2. Heat, melt, and wire brush off the solder that secures two end tanks (3) and (4) to core (5).

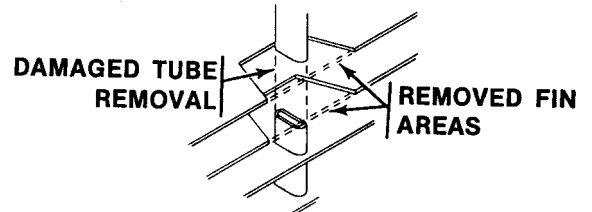
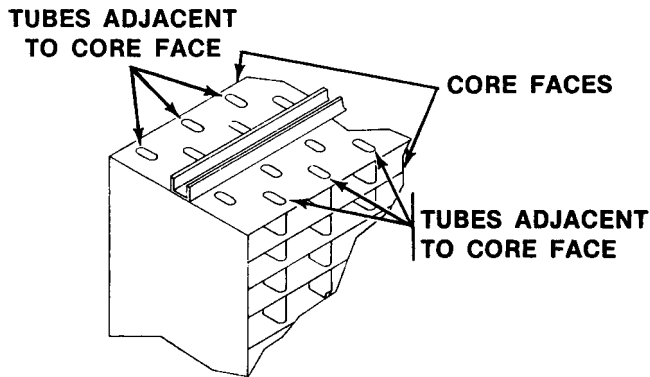
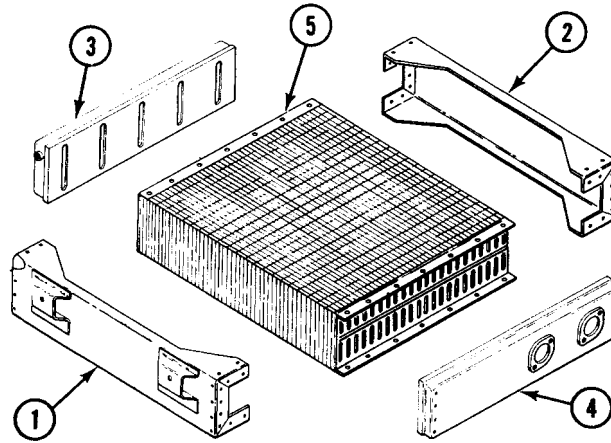

INSPECT AND REPAIR

1. Check upper and lower radiator tanks, baffles, and reinforcements. Repair solder breaks.
2. Repair shall be limited to no more than two tubes adjacent to the core face on either side.
3. Removed areas of fin shall not exceed 6-1/2 square inches (42 square centimeters) per side, per any tube repair. Length of tube splice shall not exceed 2 inches (5 cm). Tube blockage is not allowed.
4. Heat solder repair of the upper and lower tanks, overflow tube, and inlet and outlet openings is allowed.
5. Heat soldering of a core shall not exceed a linear length of 8 inches (20 cm) for any one core assembly.

6. Fin straightening is allowed.

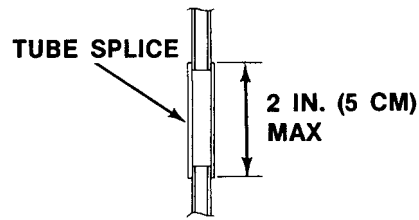

ROD

1. Disassemble radiator Step 1.
2. Wire brush rust, scale, and sediment from core tube openings.
3. Locate plugged tubes (1) by directing water into tubes. Look for flow at other end.
4. Insert a metal rod (2) long enough, and slightly smaller in diameter than tubes (1) through tubes to remove blockage.
5. Clear tubes (1) until water flows through freely.

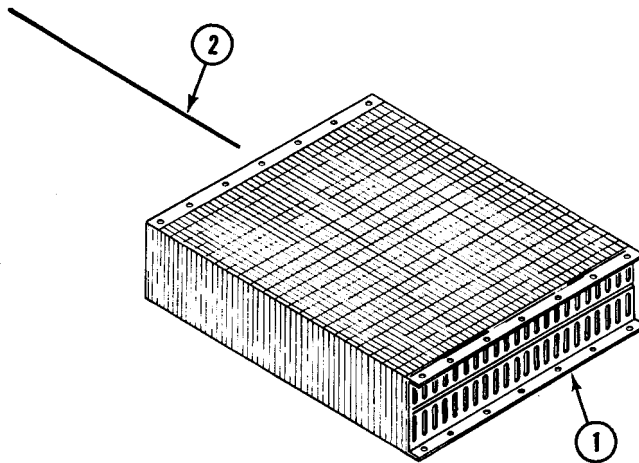

ASSEMBLE

1. Install end tanks (3) and (4) on core (5). Secure with acid core solder.
2. Install two side brackets (6) and (7) on two end tanks (3) and (4). Secure with acid core solder.

3. Test radiator Step 1. Replace leaky radiator.

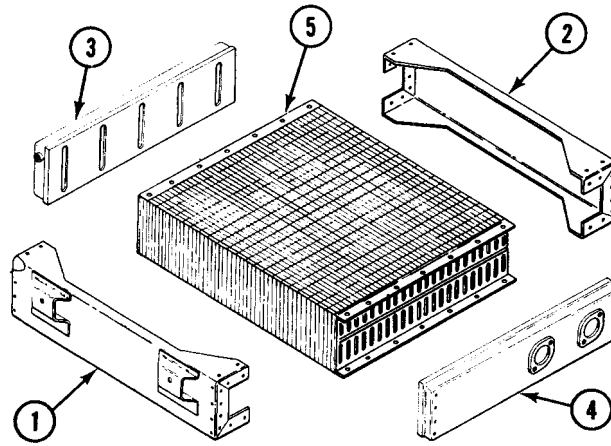
**FOLLOW-THROUGH STEPS**

1. Install radiator in carrier (see your -20).

END OF TASK

REPAIR RADIATOR AUXILIARY TANK

0020 00

THIS WORK PACKAGE COVERS:

Repair or Replacement (page 0020 00-1).

INITIAL SETUP:

Maintenance Level

Direct Support

Materials/Parts

Welding electrode (WP 0122 00, Item 35)

Tools and Special Tools

- Metal Worker's Tool Kit (WP 0120 00, Item 63)
- Trailer Mounted Welding Shop (WP 0120 00, Item 69)
- Degreaser (WP 0120 00, Item 6)
- Welder's Gloves (WP 0120 00, Item 18)
- Industrial Goggles (WP 0120 00, Item 19)
- Welder's Helmet (WP 0120 00, Item 21)
- Radiator Test Plug Set (WP 0120 00, Item 41)
- Radiator Test Stand (WP 0120 00, Item 56)
- Arc Welding Machine (WP 0120 00, Item 68)

Personnel Required

Metal Worker 44B10

References

- See your -20
- TM 9-237
- TM 43-0139

Equipment Condition

Radiator auxiliary tank removed from carrier
(see your -20)

REPAIR OR REPLACEMENT

1. Degrease tank (1).

WARNING

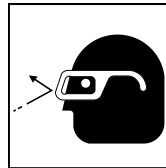

Air pressure in excess of 30 psi (207 kPa) can injure personnel. Do not direct pressurized air at yourself or others. Always wear goggles.

2. Attach tank (1) to radiator test stand.

NOTE

There are two ways to pressure test tank. If using water pressure, do Step 3, then go to Step 5. If using air pressure, go to Step 4.

3. Apply internal water pressure of 18-20 psi for minimum of 3 minutes. Check for water leaks.
4. Submerge tank (1) in water and apply pressure of 18-20 psi for minimum of 3 minutes. Check for air leaks.

NOTE

Mark areas of leaks and remove all plugs before welding.

5. Weld areas of leaks in accordance with class A, specification MIL-W-45205, see TM9-237. Use electrode type 5356. All weld sizes to be minimum requirement for leak repair.
6. Repeat WP 0020 00, Step 3 or WP 0020 00, Step 4 after welding.

7. Refinish tank (1). Treat per class 1A, specification MIL-C-5541, see TM 43-0139.

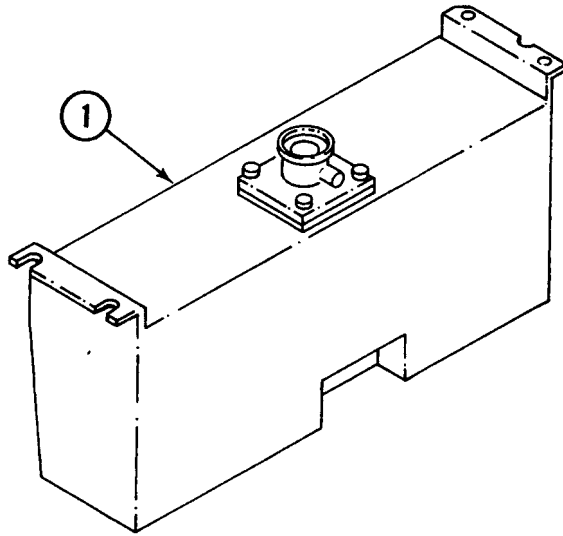
**FOLLOW-THROUGH STEPS**

1. Install radiator auxiliary tank (see your -20).

END OF TASK

REPAIR VENTILATING FAN ASSEMBLY

0021 00

THIS WORK PACKAGE COVERS:

Disassembly (page 0021 00-1).
 Assembly (page 0021 00-3).

INITIAL SETUP:

Maintenance Level

Direct Support

Personnel Required

Track Vehicle Repairer 63H10

Tools and Special Tools

General Mechanic's Tool Kit (WP 0120 00, Item 62)
 Mechanical Puller Kit (WP 0120 00, Item 44)
 Adjustable Wrench (WP 0120 00, Item 70)
 Torque Wrench (WP 0120 00, Item 73)

References

See your -20

Materials/Parts

Sealing compound (WP 0122 00, Item 25)
 Packing
 Lock washer (4)
 Lock washer (8)
 Washer (3)

Equipment Condition

Fan assembly removed from carrier (see your -20)
 Fan drive shaft and bearing housing removed from fan assembly (see your -20)

DISASSEMBLY

1. Remove four screws (18), lockwashers (19), washers (20), and cover (17) from fan housing (11). Discard lockwashers.
2. Remove six screws (12), two screws (13), eight washers (14), lockwashers (15), nuts (16), and fan housing (11) from support (2). Discard lockwashers.

3. Remove nut (10) and washer (9) from fan (7) on shaft (8). Discard washer.

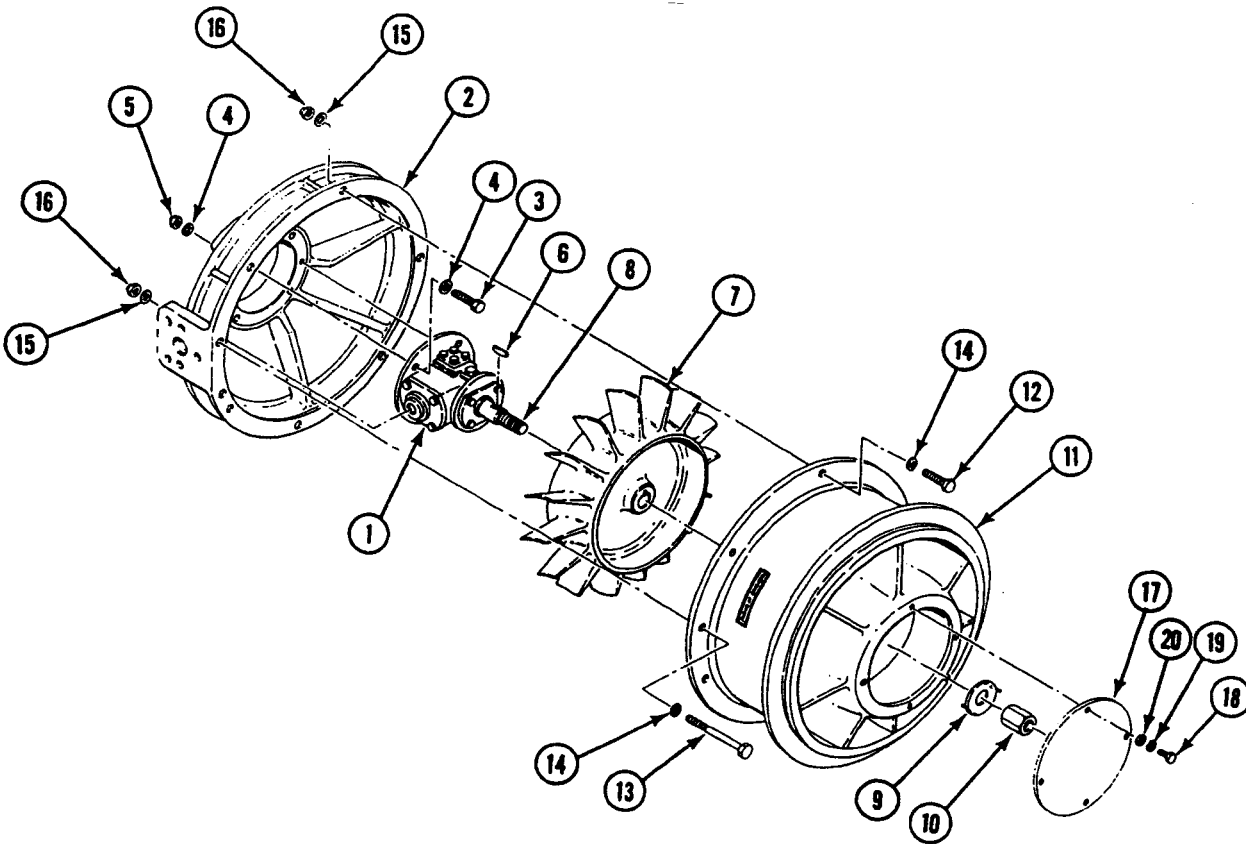

4. Use puller to remove fan (7) from gearbox (1).
5. Remove key (6) from shaft (8).
6. Remove four screws (3), nuts (5), eight washers (4), and gearbox (1) from support (2).
7. If letters on marker are illegible, replace marker (see your -20).

REPAIR VENTILATING FAN ASSEMBLY — Continued

0021 00

4. Apply sealing compound to both sides of washer (9).

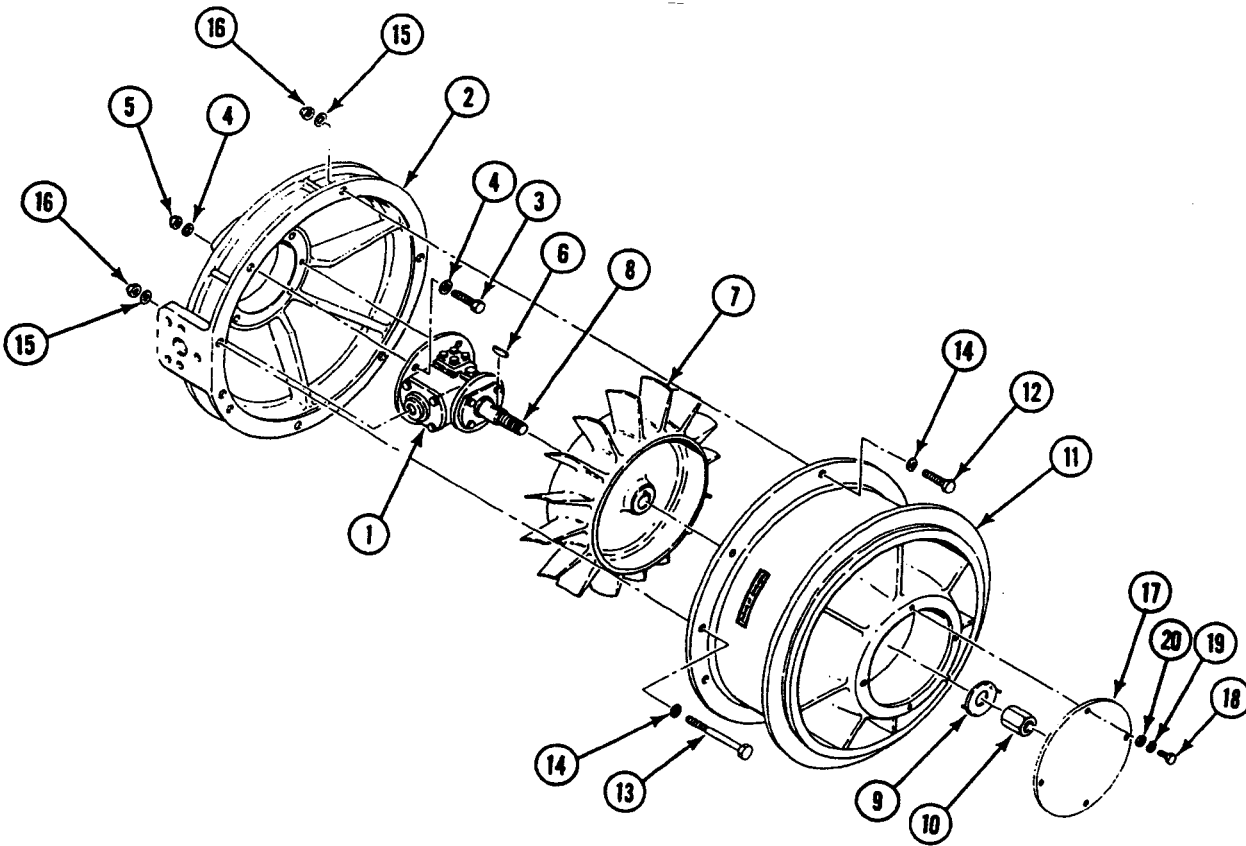

5. Install washer (9) and nut (10) on shaft (8). TORQUE NUT (10) TO 27-32 lb-ft (37-43 N.m).
6. Bend one edge of washer (9) against nut (10) and one edge against fan (7).
7. Install fan housing (11) on support (2). Secure with six screws (12), two screws (13), eight washers (14), new lockwashers (15), and nuts (16).

8. Install cover (17) on fan housing (11). Secure with four screws (18), new lockwashers (19), and washers (20).

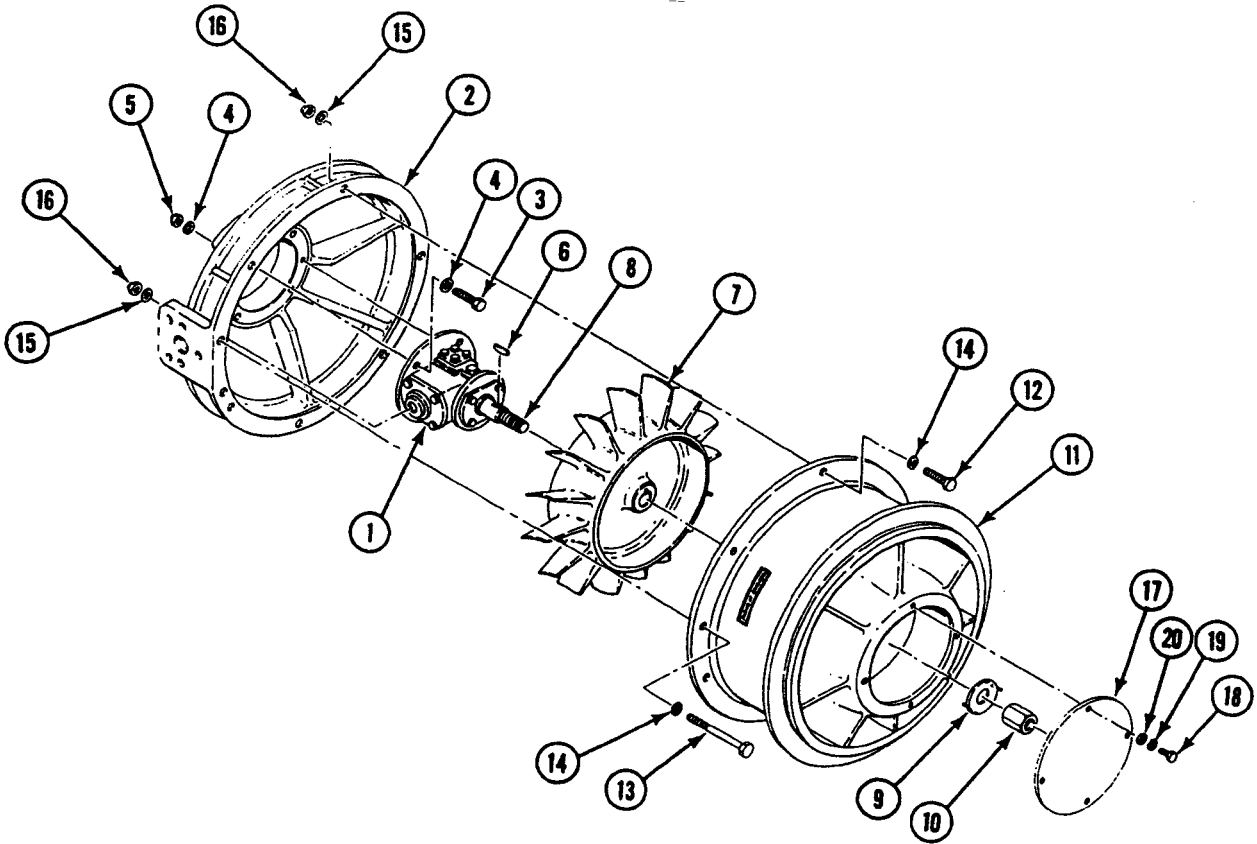

FOLLOW-THROUGH STEPS

1. Install drive shaft and bearing housing in fan assembly (see your -20).
2. Install fan assembly in carrier (see your -20).

END OF TASK

REPAIR FAN DRIVE SHAFT AND BEARING HOUSING

0022 00

THIS WORK PACKAGE COVERS:

- Disassembly (page 0022 00-1).
- Inspection (page 0022 00-1).
- Assembly (page 0022 00-2).

INITIAL SETUP:

Maintenance Level

Direct Support

Personnel Required

Track Vehicle Repairer 63H10

Tools and Special Tools

- General Mechanic's Tool Kit (WP 0120 00, Item 62)
- Hammer Face (WP 0120 00, Item 15)
- Inserted Hammer Face Holder (WP 0120 00, Item 22)
- Arbor Press (WP 0120 00, Item 43)

References

See your -20

Equipment Condition

Shaft and bearing housing removed from carrier
(see your -20)

DISASSEMBLY

1. Remove drive shaft (1) from bearing housing (2) by pressing shaft (1) out.
2. Place bearing housing (2) on flat surface. Tap outer edge of bearing (3) until bearing turns to vertical position. Tap bearing edge to remove bearing from housing.

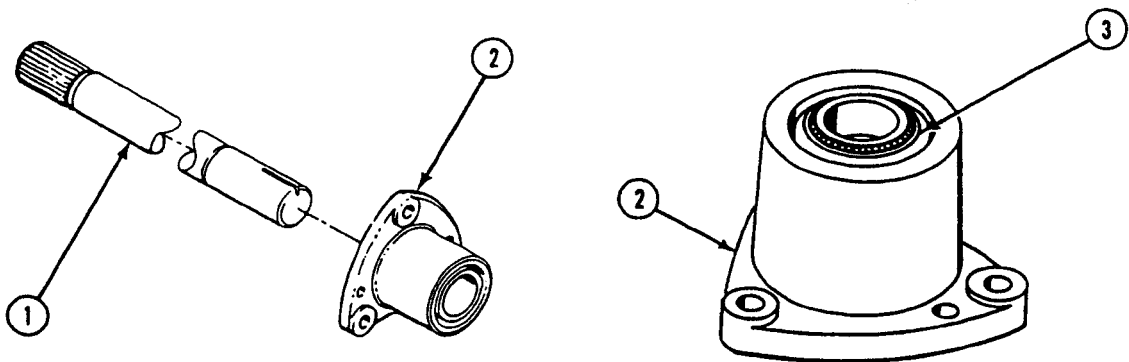

INSPECTION-ACCEPTANCE AND REJECTION CRITERIA

1. Inspect drive shaft and fan pulley for wear and damage. Replace bad drive shaft or front pulley.
2. Inspect bearing support and fan housing for wear and damage. Replace if necessary.

ASSEMBLY

1. Place bearing housing (2) on flat surface with bearing on top. Tap outer race of bearing (4) evenly until bearing race is seated flush with edge of housing. Tap edge of bearing downward to seat bearing in housing.
2. Press drive shaft (1) in bearing housing (2).

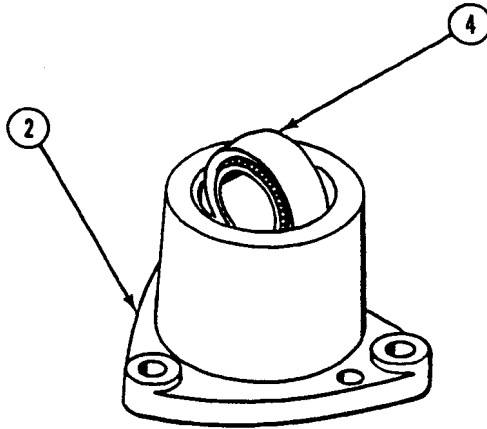
**FOLLOW-THROUGH STEPS**

1. Install shaft and bearing housing in carrier (see your -20).

END OF TASK

CHAPTER 6

DIRECT SUPPORT MAINTENANCE INSTRUCTIONS
FOR ELECTRICAL SYSTEM

WORK PACKAGE INDEX

<u>Title</u>	<u>Sequence No.</u>
REPAIR GENERATOR.....	.0023 00
REPLACE WARNING LIGHT PANEL MOUNTING BRACKET.....	.0024 00
REPAIR BATTERY.....	.0025 00
REPAIR MULTIPIN CONNECTORS.....	.0026 00
REPAIR ENGINE WIRING HARNESS.....	.0027 00
REPAIR TRANSMISSION WIRING HARNESS.....	.0028 00
REPAIR TRANSMISSION CONTROL WIRING HARNESS.....	.0029 00
REPLACE FRONT MAIN WIRING HARNESS.....	.0030 00
REPAIR FRONT MAIN WIRING HARNESS.....	.0031 00
DELETED.....	.0032 00
REPAIR SMOKE GRENADE LAUNCHER WIRING HARNESS (M113A3 AND M1059A3 ONLY).....	.0033 00
REPAIR STEERING LOCK SWITCH WIRING HARNESS.....	.0034 00

REPAIR GENERATOR

0023 00

THIS WORK PACKAGE COVERS:

Repair or Replacement (page 0023 00-1).

INITIAL SETUP:

Maintenance Level

Direct Support

References

TM 2920-257-30&P
See your -20

Personnel Required

Track Vehicle Repairer 63H10

Equipment Condition

Generator removed (see your -20)

REPAIR OR REPLACEMENT

1. Repair generator. See TM 2920-257-30&P.

END OF TASK

REPLACE WARNING LIGHT PANEL MOUNTING BRACKET

0024 00

THIS WORK PACKAGE COVERS:

Removal (page 0024 00-1).
 Installation (page 0024 00-2).

INITIAL SETUP:

Maintenance Level

Direct Support

Personnel Required

Track Vehicle Repairer 63H10

Tools and Special Tools

General Mechanic's Tool Kit (WP 0120 00, Item 62)

References

See your -10

Materials/Parts

Bracket
 Cotter pin (2)
 Insert (2)
 Locknut (2)
 Thumbscrew (2)

Equipment Condition

Engine stopped (see your -10)
 Carrier blocked (see your -10)
 M17 periscope removed (see your -10)

REMOVAL

1. Remove two locknuts (1), screws (2), washers (3), mounts (4), and panel (5) from bracket (6). Discard locknuts and bracket. Support panel after removing screws.

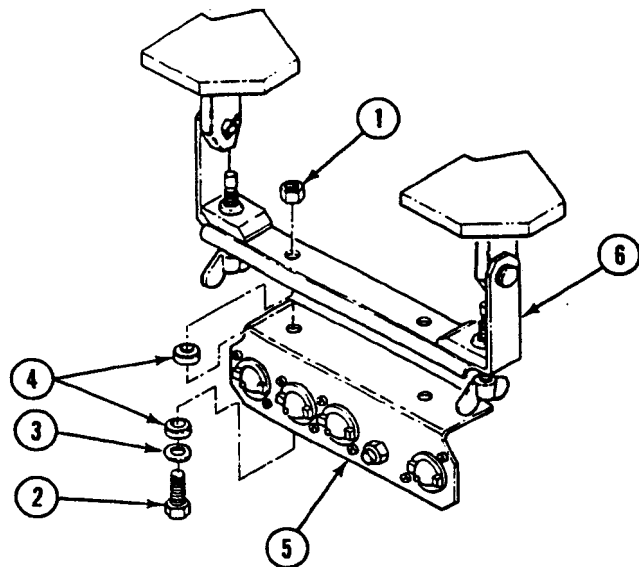
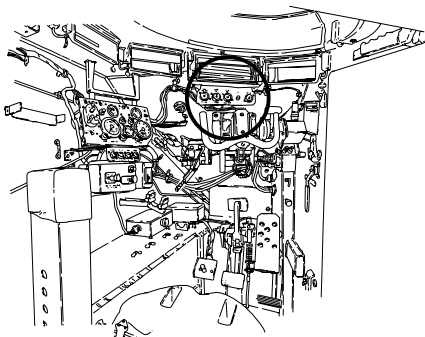

2. Remove two cotter pins (7), four washers (8), two headed pins (9), and bracket (6) from hull. Discard cotter pins.

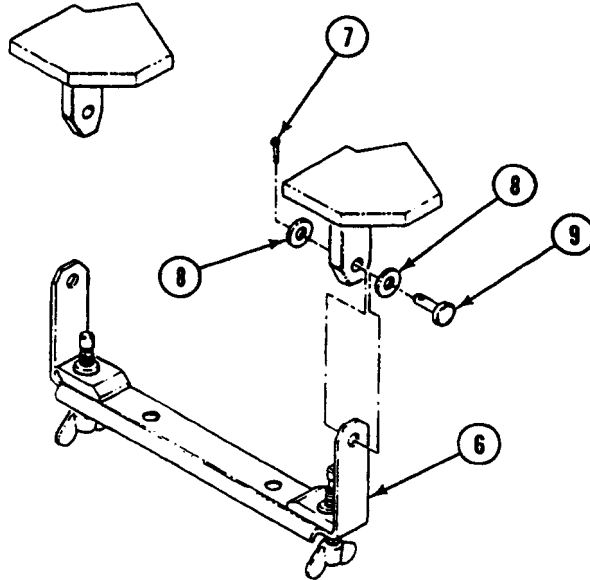

INSTALLATION

1. Install two new inserts and lock rings into new bracket (WP 0040 00).
2. Install two new thumbscrews (1) into new bracket (2). Stake first two threads at end of thumbscrews after installing into bracket.

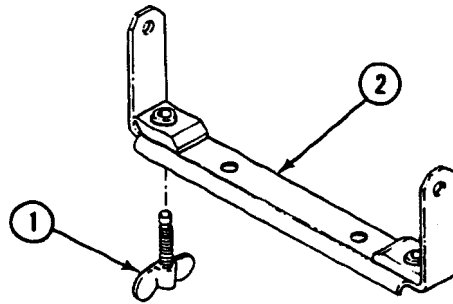

3. Install four washers (8), two headed pins (9), and two new cotter pins (7) holding bracket (6) to hull.

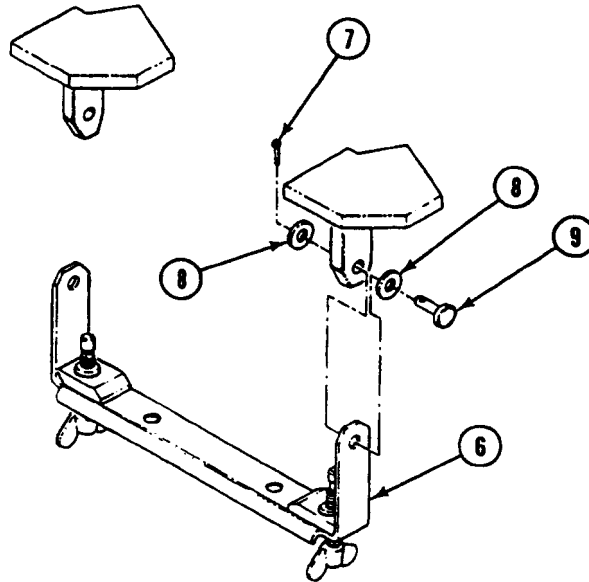

4. Install panel (5) on bracket (6) with two screws (2), washers (3), mounts (4), and new locknuts (1).

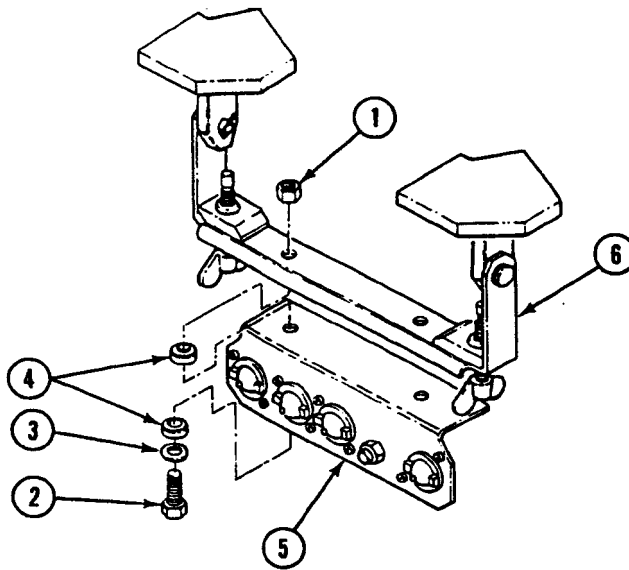

FOLLOW-THROUGH STEPS

1. Install M17 periscope (see your -10).

END OF TASK

REPAIR BATTERY

0025 00

THIS WORK PACKAGE COVERS:

Repair or Replacement (page 0025 00-1).

INITIAL SETUP:

Maintenance Level

Direct Support

References

TM 9-6140-200-14

Tools and Special Tools

Automotive Fuel and Electrical System Repair Tool Kit
(WP 0120 00, Item 59)

Equipment Condition

Personnel Required

Fuel and Elec Sys Rep 63G10

Battery on workbench

REPAIR OR REPLACEMENT

1. Repair batteries. See TM 9-6140-200-14.

END OF TASK

REPAIR MULTIPIN CONNECTORS

0026 00

THIS WORK PACKAGE COVERS:

- Receptacle removal (page 0026 00-1).
- Receptacle installation (page 0026 00-2).
- Cable connector removal (page 0026 00-2).
- Cable connector installation (page 0026 00-3).

INITIAL SETUP:

Maintenance Level

Direct Support

Materials/Parts

- Insulation tape (WP 0122 00, Item 19)
- Tin alloy solder (WP 0122 00, Item 33)
- Contacts (AR)

Tools and Special Tools

- Automotive Fuel and Electrical System Repair Tool Kit (WP 0120 00, Item 59)
- Electrical Connector Tool Kit (WP 0120 00, Item 60)
- Digital Multimeter (WP 0120 00, Item 38)
- Soldering Gun (WP 0120 00, Item 54)

Personnel Required

Fuel and Elec Sys Rep 63G10

Equipment Condition

Repairable parts on workbench

REMOVAL

REMOVE RECEPTACLE

NOTE

Use same procedure for repairing single or multiple lead, and male or female receptacle.

1. Loosen nut (1) from receptacle (2). Slide nut back on leads (3).
2. Remove grommet (4) with contacts (5) from rear of receptacle (2).
3. Push leads (3) into grommet (4) until contacts (5) are fully exposed on other side of grommet. Clip or desolder leads from contacts. Discard contacts.
4. Remove grommet (4) and nut (1) from leads (3).

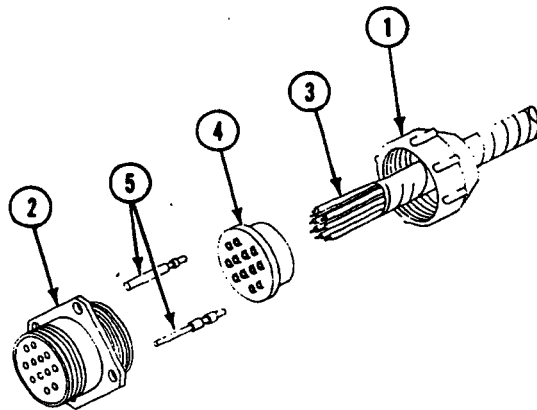

INSTALLATION**INSTALL RECEPTACLE****NOTE**

If replacing lead, cut new wire from bulk supply. Measure original length, gage, and type of wire.

1. Strip insulation from leads (3) to uncover just enough wire to fill well in contact (5).
2. Slide nut (1) over leads (3).
3. Push leads (3) through grommet (4) and insert in new contacts (5).

NOTE

Make sure leads pass through proper lettered hole in grommet.

4. Solder leads (3) in contacts (5) and press contacts into grommet (4). Check leads for continuity.
5. Align and install grommet (4) in receptacle (2). Secure with nut (1).

REMOVE CABLE CONNECTOR**NOTE**

Use same procedure for repairing single or multiple lead, and male or female cable connectors.

1. Loosen retaining nut (1) from plug (2). Slide nut back on cable (3).
2. Pull grommet (4) with contacts (5) from rear of plug (2).
3. Remove plug (2) and coupling nut (6) from cable (3).
4. Push leads of cable (3) into grommet (4) until contacts (5) are fully exposed on other side of grommet. Clip or desolder leads from contacts. Discard contacts.
5. Remove grommet (4) and retaining nut (1) from cable (3).

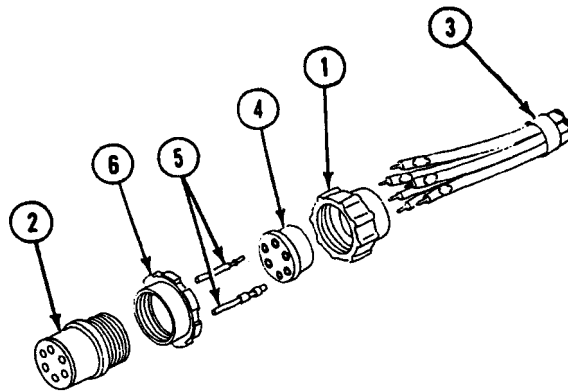

INSTALL CABLE CONNECTOR**NOTE**

If replacing lead, cut new wire from bulk supply. Measure original length, gauge, and type of wire.

1. Strip insulation from leads of cable (3) to uncover just enough wire to fill well in contact (5).
2. Slide retaining nut (1) and coupling nut (6) on cable (3).
3. Push leads of cable (3) through grommet (4) and insert in new contacts (5).

NOTE

Make sure leads pass through proper lettered hole in grommet.

4. Solder leads in contacts (5) and press contacts into grommet (4). Check leads for resistance.
5. Align and install grommet (4) in plug (2). Secure with retaining nut (1).

END OF TASK

REPAIR ENGINE WIRING HARNESS

0027 00**THIS WORK PACKAGE COVERS:**

Repair or Replacement (page 0027 00-1).

INITIAL SETUP:Maintenance Level

Direct Support

Personnel Required

Fuel and Elec Sys Rep 63G10

Tools and Special ToolsAutomotive Fuel and Electrical System Repair Tool Kit
(WP 0120 00, Item 59)

Electrical Connector Tool Kit (WP 0120 00, Item 60)

Digital Multimeter (WP 0120 00, Item 38)

References

See your -20

Materials/Parts

Insulation tape (WP 0122 00, Item 19)

Equipment Condition

Engine wiring harness removed (see your -20)

REPAIR OR REPLACEMENT

1. Perform continuity check on engine wiring harness assembly to determine which parts require repair or replacement.
2. Repair connectors as required (WP 0026 00).
3. Repair leads and/or small connectors as required.
4. Repeat continuity check on engine wiring harness assembly to determine that repairs have been completed.
5. Use insulation tape to bind wiring harness.

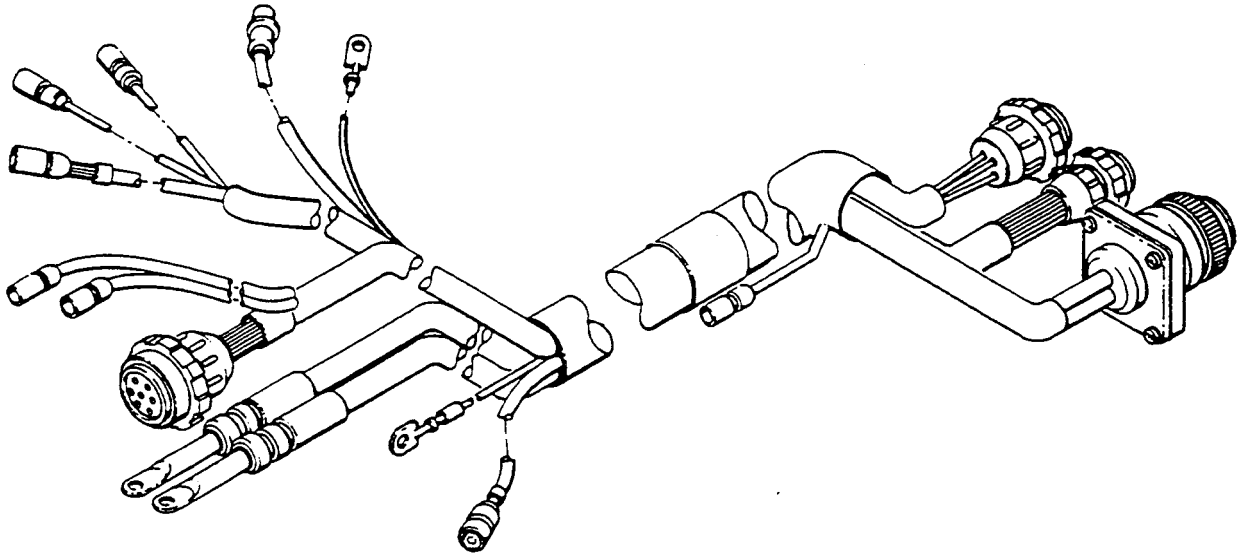

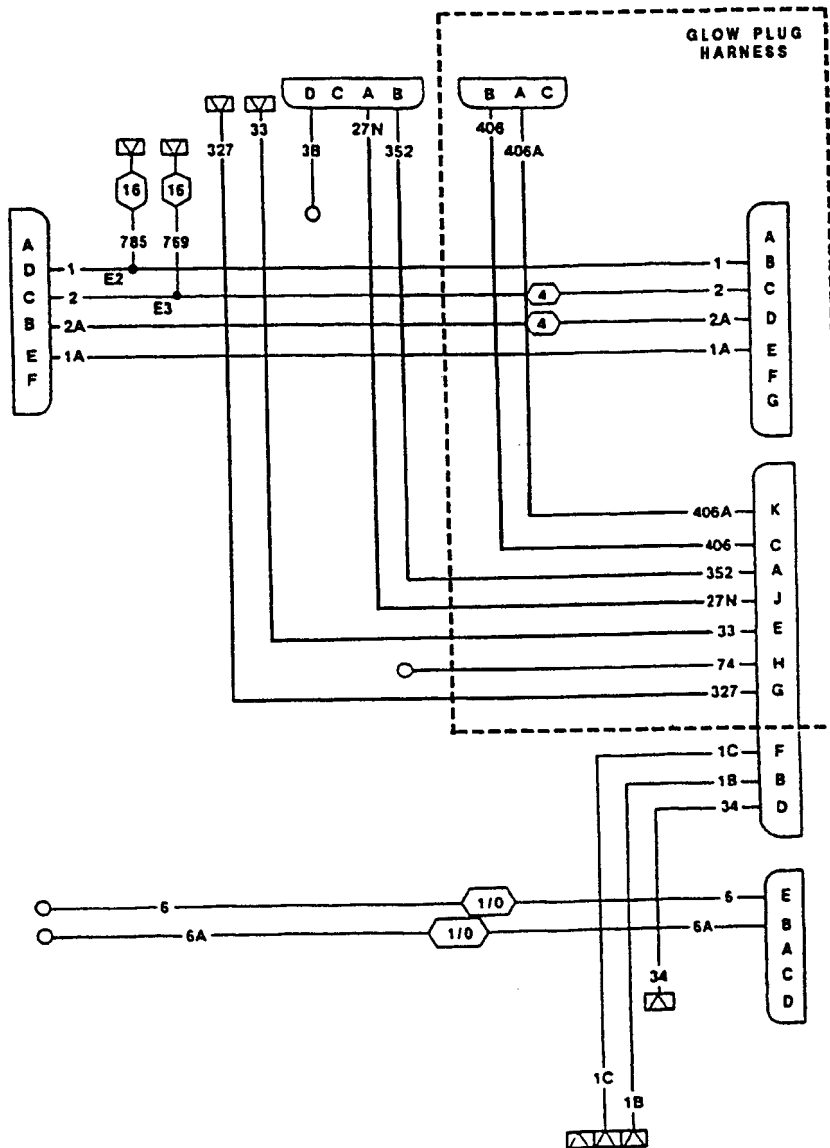

FOLLOW-THROUGH STEPS

1. Install engine wiring harness assembly (see your -20).

END OF TASK

REPAIR TRANSMISSION WIRING HARNESS

0028 00

THIS WORK PACKAGE COVERS:

Repair or Replacement (page 0028 00-1).

INITIAL SETUP:

Maintenance Level

Direct Support

Personnel Required

Fuel and Elec Sys Rep 63G10

Tools and Special Tools

Automotive Fuel and Electrical System Repair Tool Kit
(WP 0120 00, Item 59)
Electrical Connector Tool Kit (WP 0120 00, Item 60)
Digital Multimeter (WP 0120 00, Item 38)

References

See your -20

Materials/Parts

Insulation tape (WP 0122 00, Item 19)

Equipment Condition

Transmission wiring harness removed (see your -20)

REPAIR OR REPLACEMENT

1. Perform continuity check on transmission wiring harness to determine which parts require repair or replacement.
2. Repair connector(s) as required (WP 0026 00).
3. Repair small connectors as required (see your -20).
4. Repeat continuity check on transmission wiring harness assembly to determine that repairs have been completed.

5. Use insulation tape to bind wiring harness.

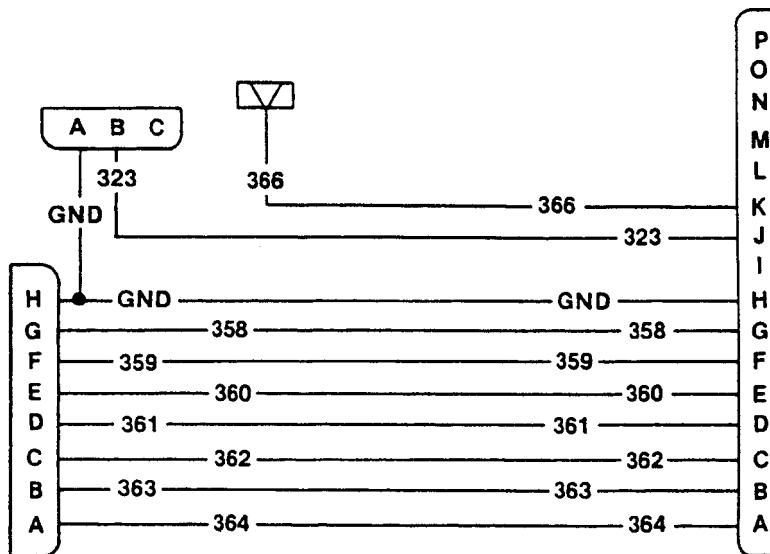
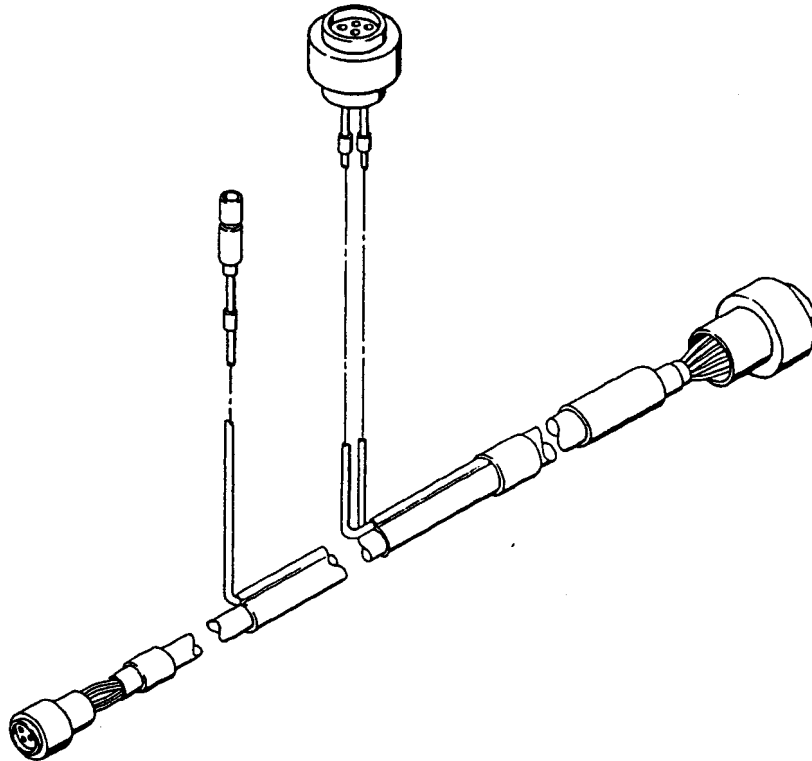

WIRING DIAGRAM

FOLLOW-THROUGH STEPS

1. Install transmission wiring harness assembly (see your -20).

END OF TASK

REPAIR TRANSMISSION CONTROL WIRING HARNESS

0029 00

THIS WORK PACKAGE COVERS:

Repair or Replacement (page 0029 00-1).

INITIAL SETUP:

Maintenance Level

Direct Support

Personnel Required

Fuel and Elec Sys Rep 63G10

Tools and Special Tools

Automotive Fuel and Electrical System Repair Tool Kit
(WP 0120 00, Item 59)
Electrical Connector Tool Kit (WP 0120 00, Item 60)
Digital Multimeter (WP 0120 00, Item 38)

References

See your -20

Materials/Parts

Insulation tape (WP 0122 00, Item 19)

Equipment Condition

Wiring harness removed (see your -20)

REPAIR OR REPLACEMENT

1. Perform continuity check on transmission control wiring harness to determine which parts require repair or replacement.
2. Repair connector(s) as required (WP 0026 00).
3. Repair terminals as required (see your -20).
4. Repeat continuity check on transmission control wiring harness assembly to determine that repairs have been completed.

5. Use insulation tape to bind wiring harness.

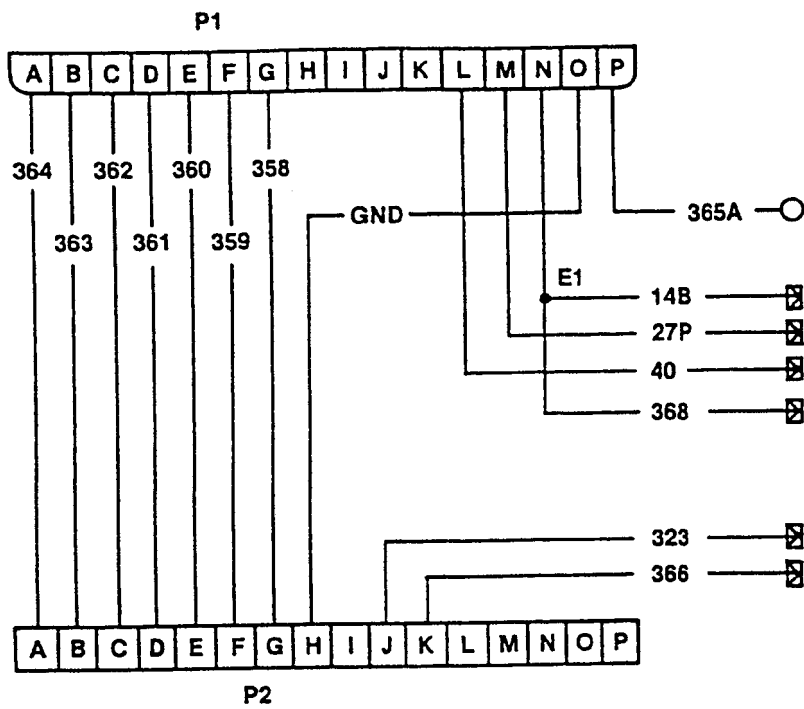
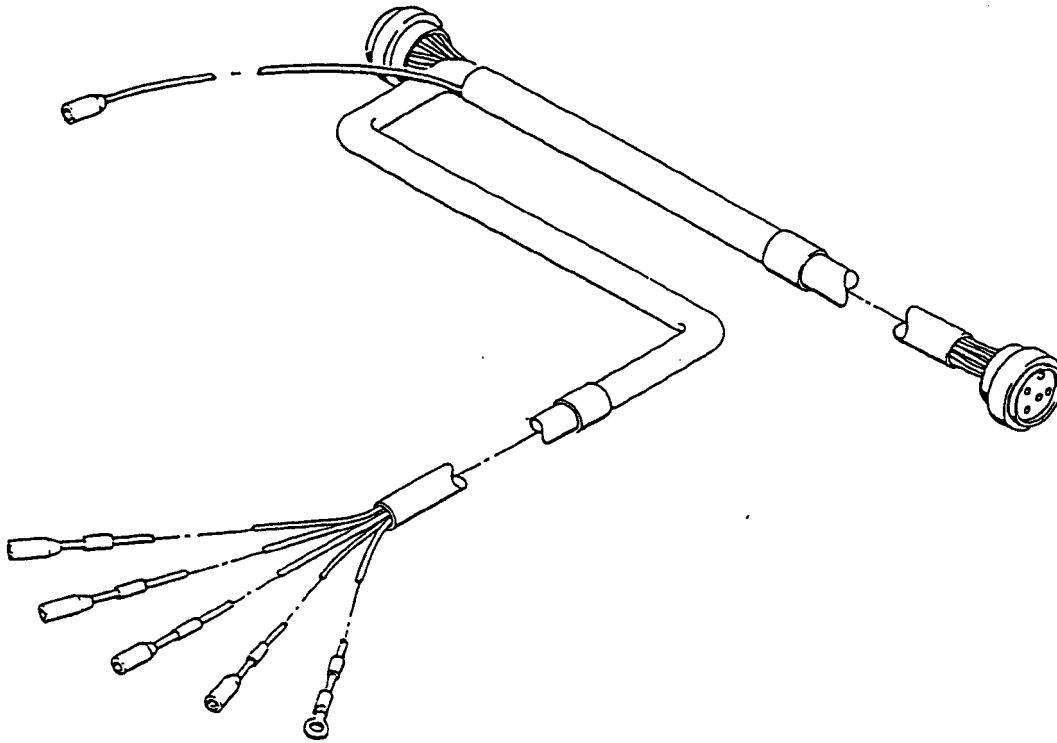

FOLLOW-THROUGH STEPS

1. Install transmission control wiring harness (see your -20).

END OF TASK

REPLACE FRONT MAIN WIRING HARNESS

0030 00

THIS WORK PACKAGE COVERS:

- Removal (page 0030 00-1).
- Installation (page 0030 00-20).

INITIAL SETUP:

Maintenance Level

Direct Support

Personnel Required

Fuel and Elec Sys Rep 63G10
Helper (H)

Tools and Special Tools

- Automotive Fuel and Electrical System Repair Tool Kit (WP 0120 00, Item 59)
- Electrical Connector Tool Kit (WP 0120 00, Item 60)
- General Mechanic's Tool Kit (WP 0120 00, Item 62)
- Open End Wrench, 1-1/8 inch (WP 0120 00, Item 71)

References

- See your -10
- See your -20

Materials/Parts

- Locknut
- Locknut (13)
- Locknut (16)
- Lockwasher (4)
- Lockwasher (22)
- Tiedown strap (3)

Equipment Condition

- Engine stopped (see your -10)
- Carrier blocked (see your -10)
- Trim vane lowered (see your -10)
- Power plant access cover removed (see your -10)
- Power plant front access door raised (see your -10)
- Battery ground strap disconnected (see your -20)

REMOVAL

1. Remove two nuts (1), mounts (2), washers (3), and screws (4) that secure instrument panel (5) to two struts (6) and (7).

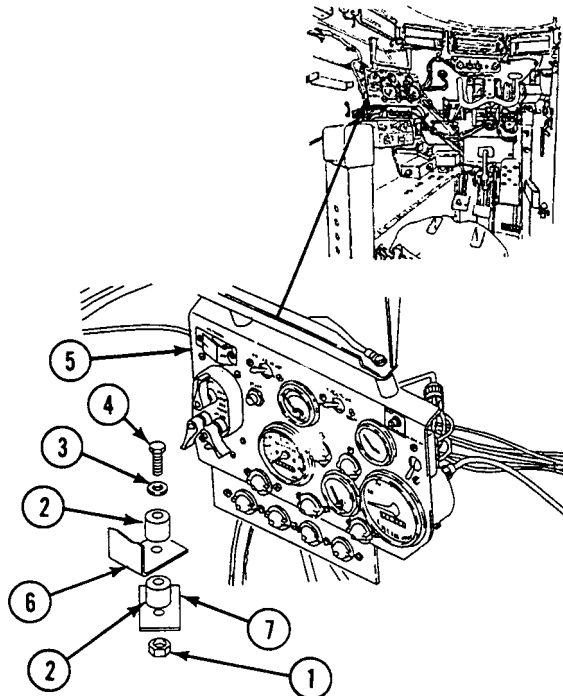

REPLACE FRONT MAIN WIRING HARNESS — Continued

0030 00

2. Support instrument panel (5). Remove two screws (8), washers (9), and lockwasher (10) that secure ground lead (11), WAIT indicator ground lead (17) (glow plug system only), and upper support (12) on two mounts (13). Discard lockwasher.
3. Support instrument panel (5) on two struts to gain access to rear of panel.
4. Remove knurled nut (14) and WAIT indicator (15) with lockwasher (16) from instrument panel (5) (glow plug system only).

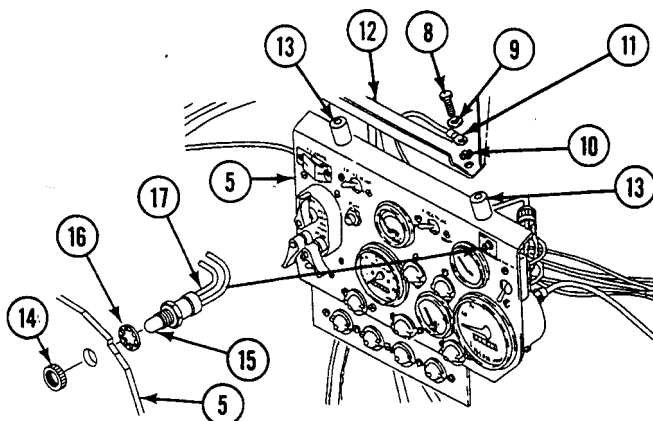

5. Disconnect circuits 24 (1), 23 (2), 22 (3), and 21 (4) leads from rear main wiring harness (5).
6. Disconnect connector (6) from light selector switch (7).
7. Disconnect circuit 452A lead (8) from bilge pump switch connector (9).

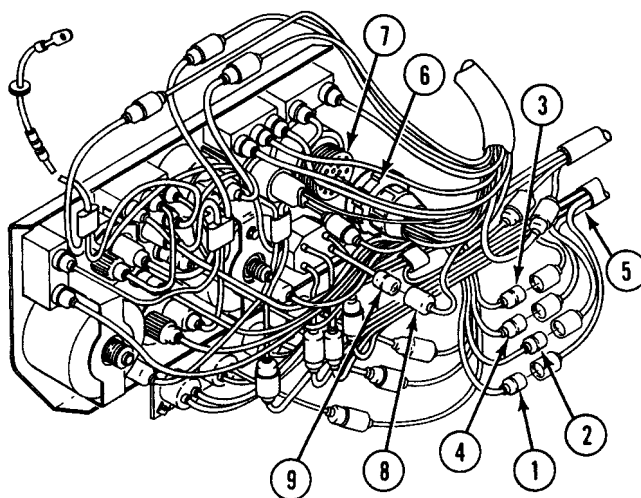

REPLACE FRONT MAIN WIRING HARNESS — Continued

0030 00

8. Disconnect circuit 452B lead (10) from bilge pump ON indicator light (11).

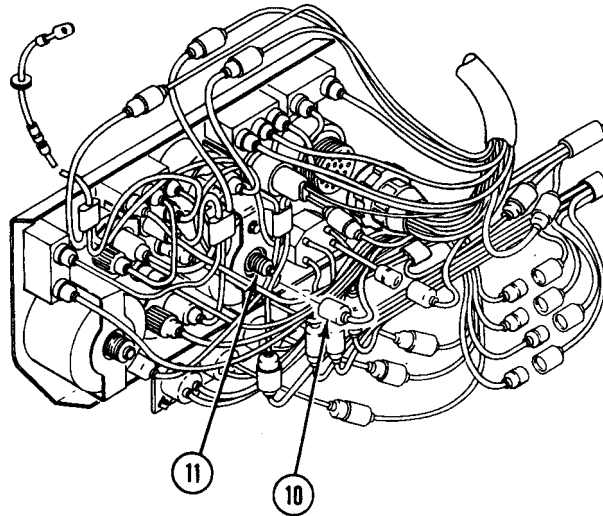

9. Disconnect three circuit 40 leads (12) from two instrument panel lights (13) and transmission control wiring harness connector (14).
10. Disconnect circuit 366 lead (15) from circuit 366 connector (16).

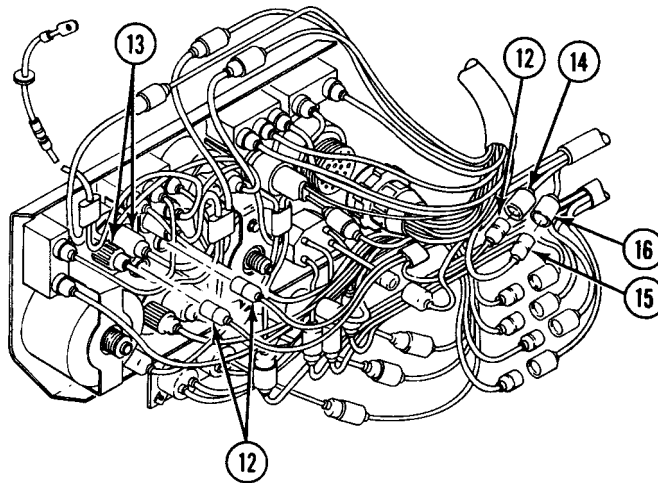

REPLACE FRONT MAIN WIRING HARNESS — Continued

0030 00

11. Disconnect circuit 15 (17), 25A (18), 27F (19), and 14 (20) leads from instrument panel wiring harness connectors.

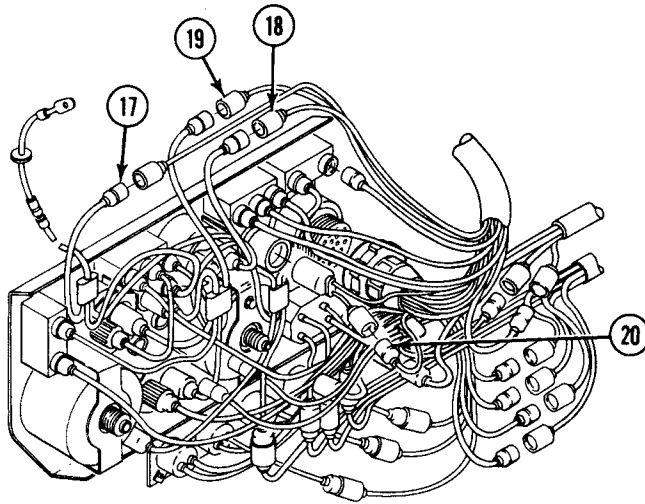

12. Disconnect circuit 516A lead (1) from infrared (I.R.) power pack switch (2).
13. Disconnect circuit 74 lead (3) from starter switch (4) and lead 14 (5) from connector 14B (6).

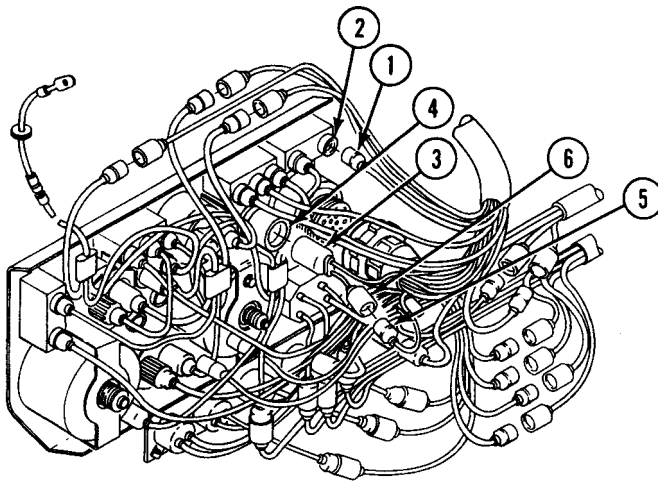

14. Disconnect circuit 33 lead (7) from engine coolant temperature gauge (8).
15. Disconnect circuit 406 lead (9) from air box heater switch (10).

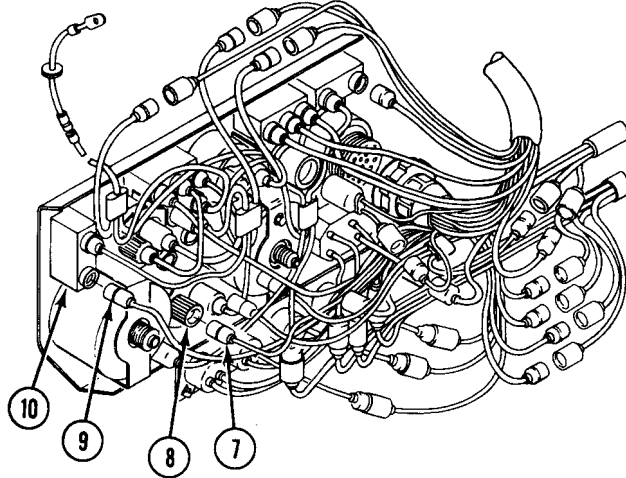

16. Disconnect circuit 520 lead (11) from infrared (I.R.) B.O. selector switch (12).
17. Disconnect circuit 19 lead (13) from infrared (I.R.) B.O. selector switch (12).
18. Disconnect circuits 514 and 515 lead (14) from infrared (I.R.) B.O. selector switch (12).

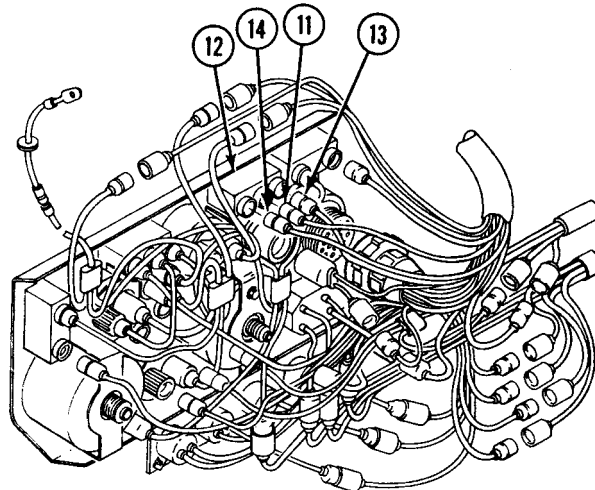

19. Disconnect circuits 519 and 519A lead (15) from headlights high beam indicator (16).

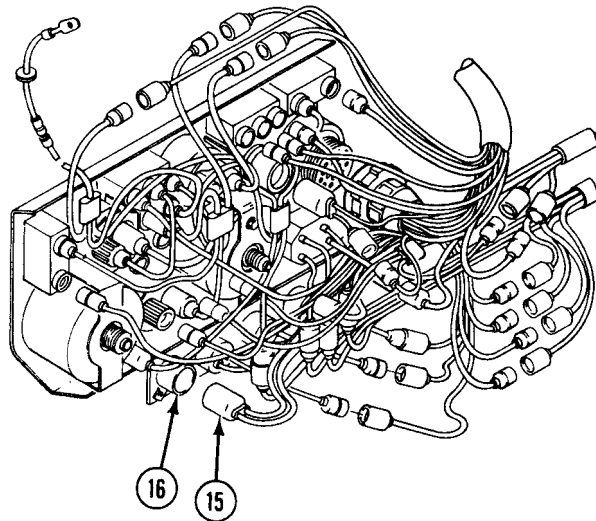

20. Disconnect circuit 367 lead (1) from transmission low oil pressure indicator connector (2).

21. Disconnect circuit 370 lead (3) from connector (4).

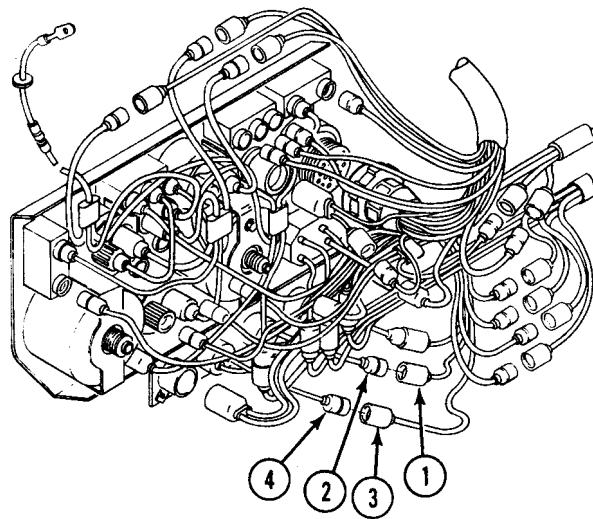

REPLACE FRONT MAIN WIRING HARNESS — Continued

0030 00

22. Remove front main wiring harness (5) from instrument panel (6).

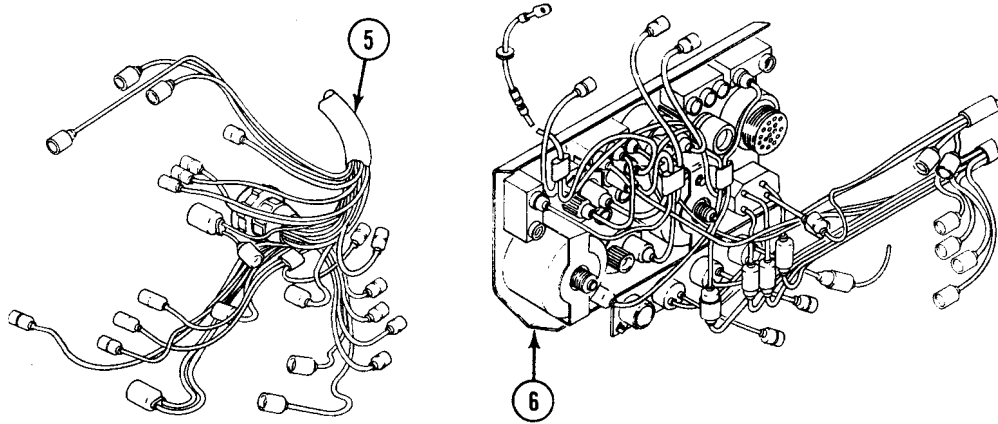

23. Remove eight locknuts (7), washers (8), and screws (9) that secure master switch panel (10) on distribution box (11). Pull master switch panel away from box. Discard locknuts.

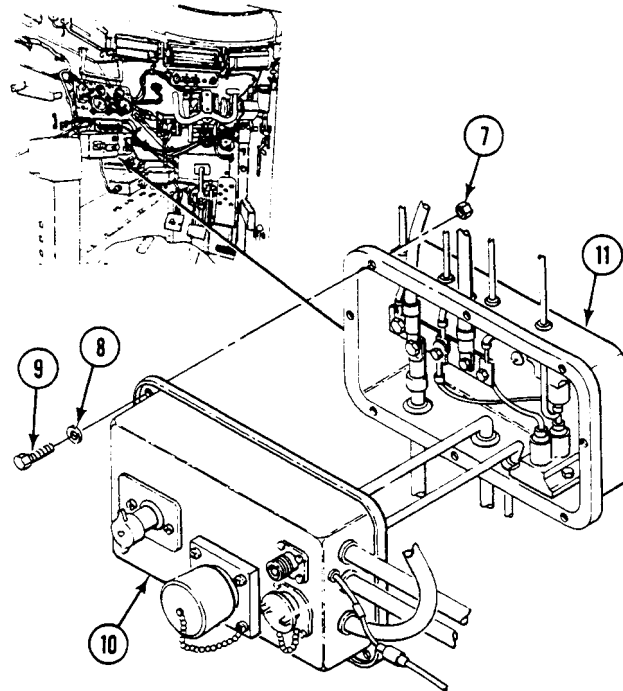

REPLACE FRONT MAIN WIRING HARNESS — Continued

0030 00

24. Remove locknut (12) and screw (13) that secure circuit 2 (14), 6 (15), and 400 (16) leads on conductor bus (17) of master switch panel (10). Remove nut (18) and lockwasher (19) that secure circuit 2A (20) on conductor bus. Remove circuit 2A (20) and circuit 2 (14) leads from master switch panel through distribution box (11). Discard locknut.

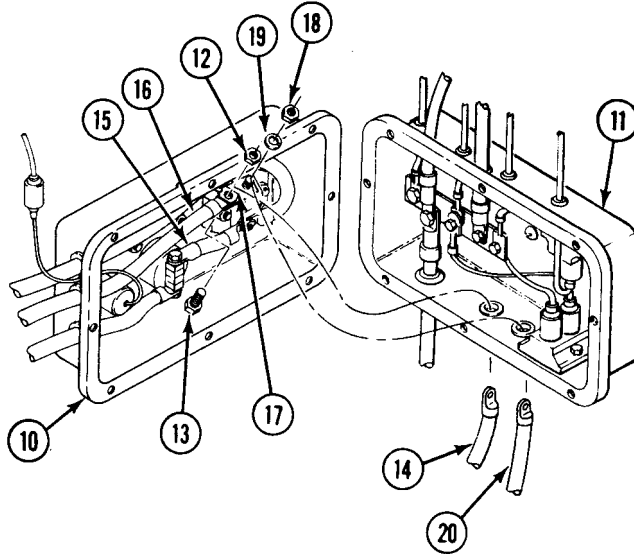

25. Remove screw (1) and lockwasher (2) that secure circuit 6 (3) and circuit 6A (4) leads on bus bar (5) of distribution box (6). Remove circuit 6 and 6A leads from distribution box. Discard lockwasher.

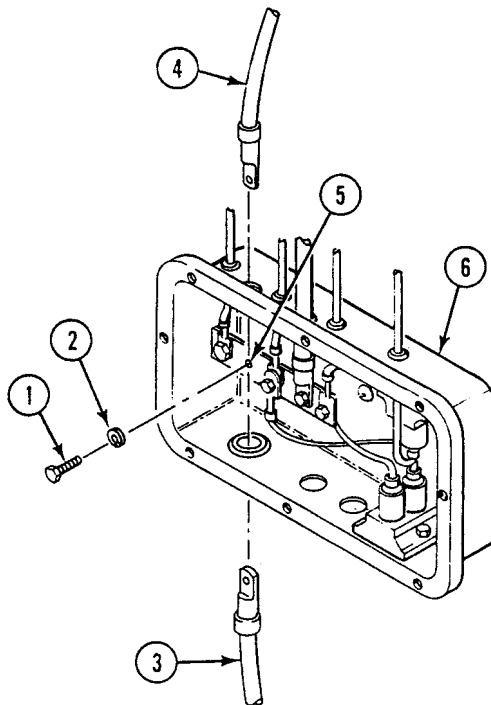

REPLACE FRONT MAIN WIRING HARNESS — Continued

0030 00

26. Remove two screws (7), lockwashers (8) and two clamps (9) that secure front main wiring harness (10) on two weldnuts (11) on side plate of hull. Discard lockwashers.

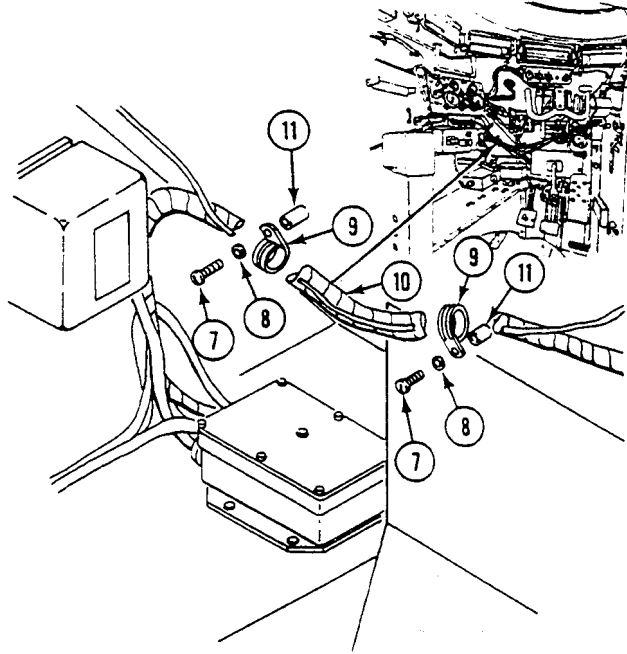

27. Disconnect, from inside of power plant compartment, four connectors that connect right headlight wiring harness (12), generator regulator lead (13), and two power plant harness leads (14)(15) on driver's bulkhead. Remove connectors from bulkhead.

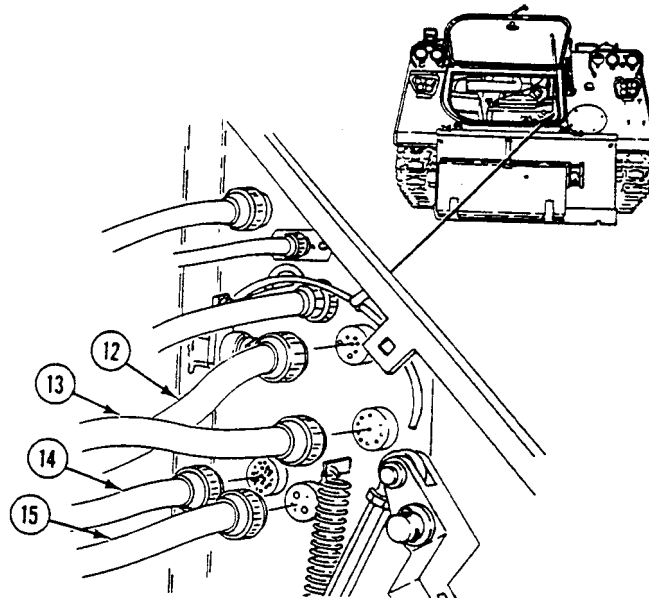

28. Remove 16 screws (16), and locknuts (17) that secure four connectors (18) on driver's bulkhead. Remove four connectors from bulkhead. Discard locknuts.

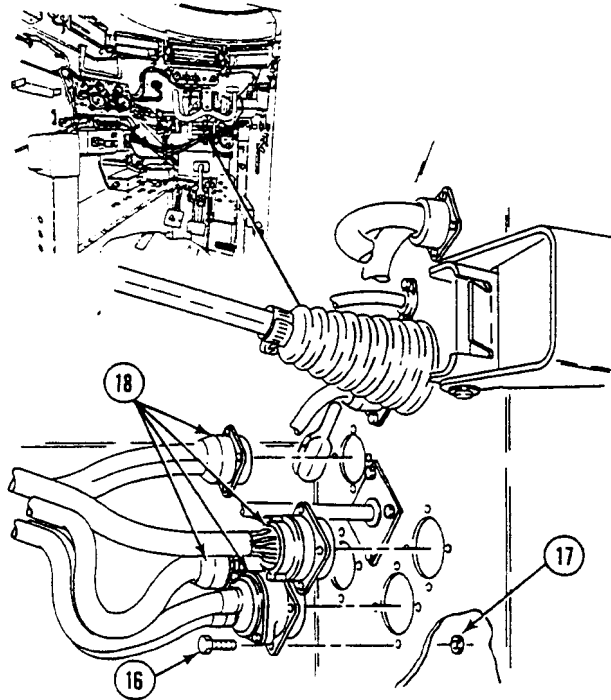

29. Disconnect two connectors (1) from generator regulator (2).

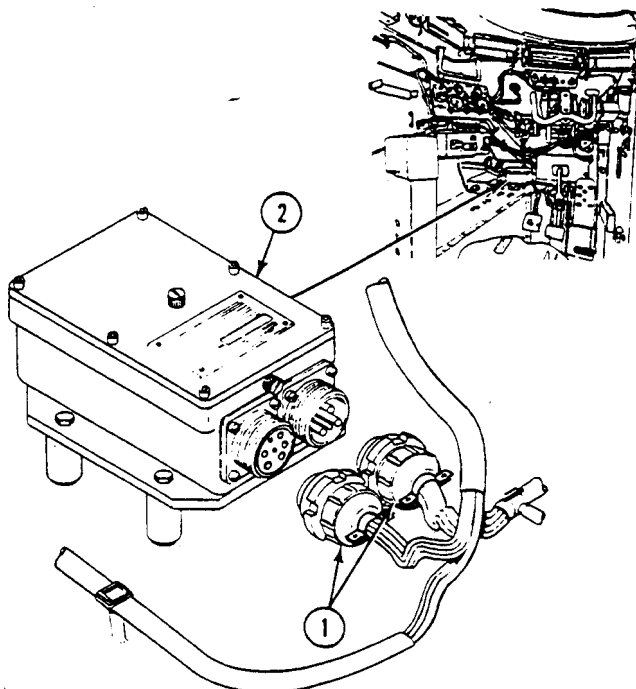

30. Disconnect circuit 516A lead (3) from infrared power pack (4).

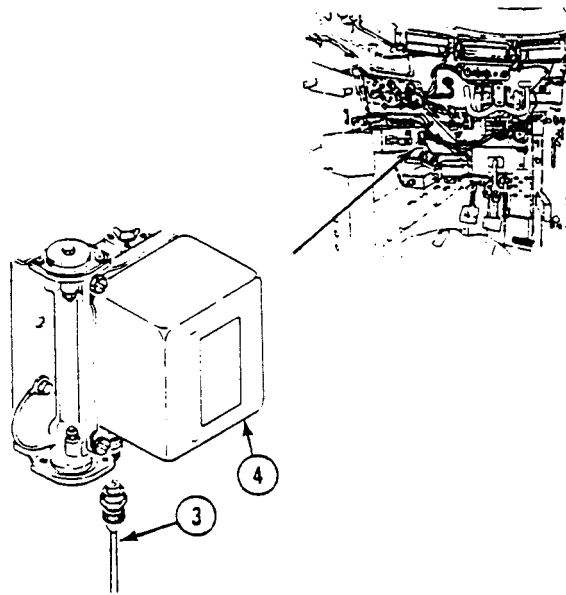

31. Remove two screws (5), lockwashers (6), and four flat washers (7) securing bilge pump strainer (8) to weld nuts. Remove strainer. Discard lockwashers.
32. Disconnect circuit 452 lead (9) from front bilge pump (10).

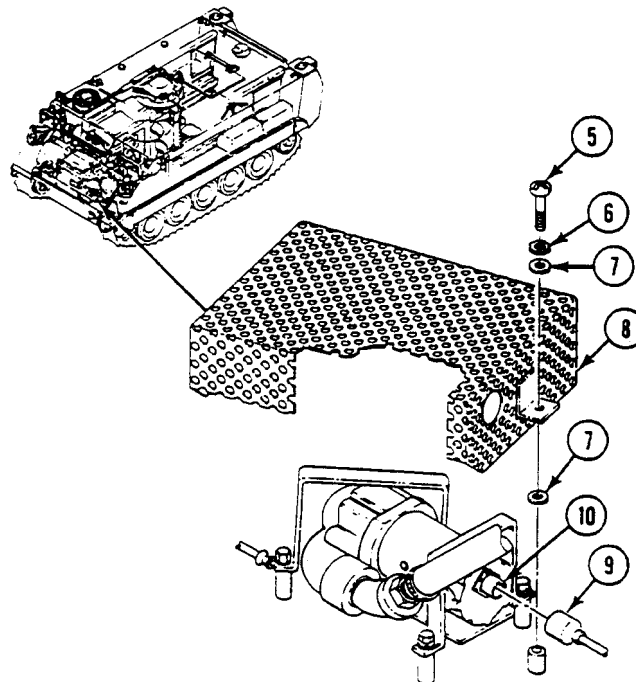

33. Remove two front screws (11) and lockwashers (12) from voltage regulator mounting plate (13). Discard lockwashers.
34. Loosen two rear screws (14) from voltage regulator mounting plate (13). Slide voltage regulator (15) from mounts for access.

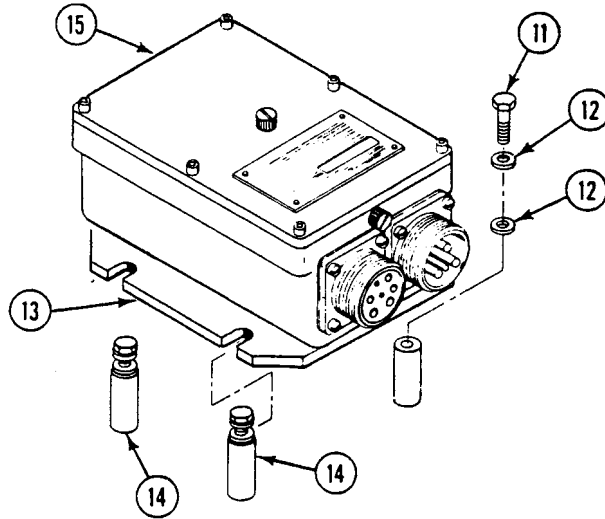

35. Remove from inside of power plant compartment three screws (1), lockwashers (2), and clamps (3) that secure wiring harness (4) on driver's bulkhead. Remove wiring harness from bulkhead. Discard lockwashers.

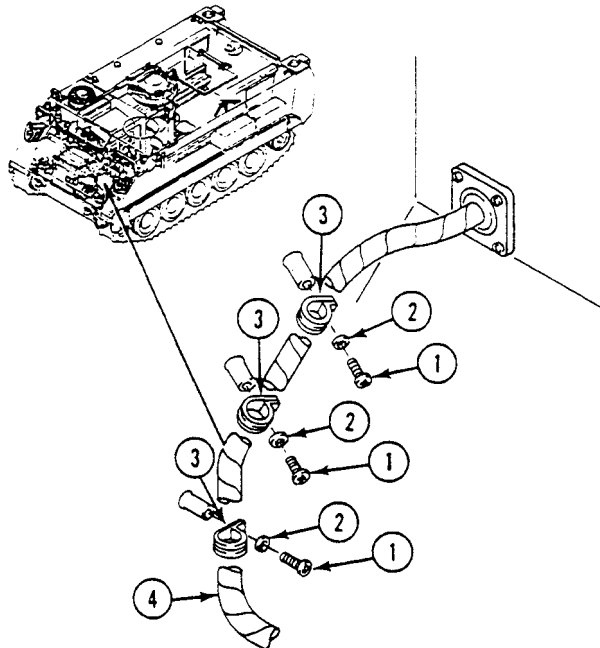

36. Remove four screws (5), locknuts (6), and cover (7) that secure the wiring harness (4) on driver's compartment bulkhead. Pull harness through bulkhead into driver's compartment. Discard locknuts.

37. Disconnect connector (8) from dimmer switch (9).

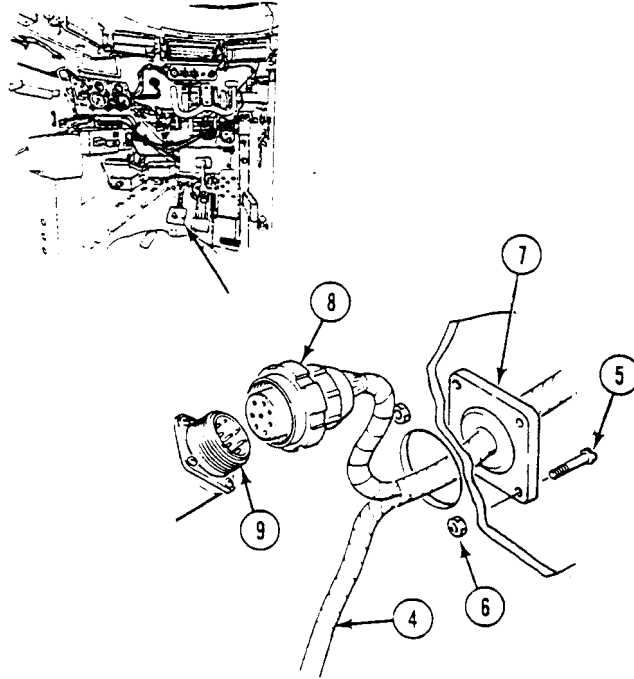

38. Disconnect circuits 75A (10), 75B (11), 366A (12), and 366 (13) leads from stop switch (14).

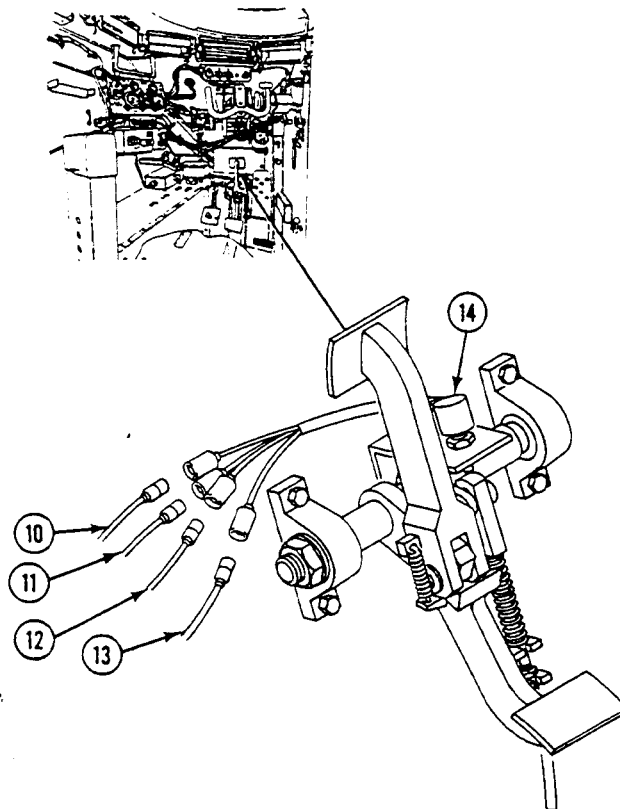

39. Disconnect circuits 366A (1), 367 (2), and 370 (3) leads from parking brake switch (4).

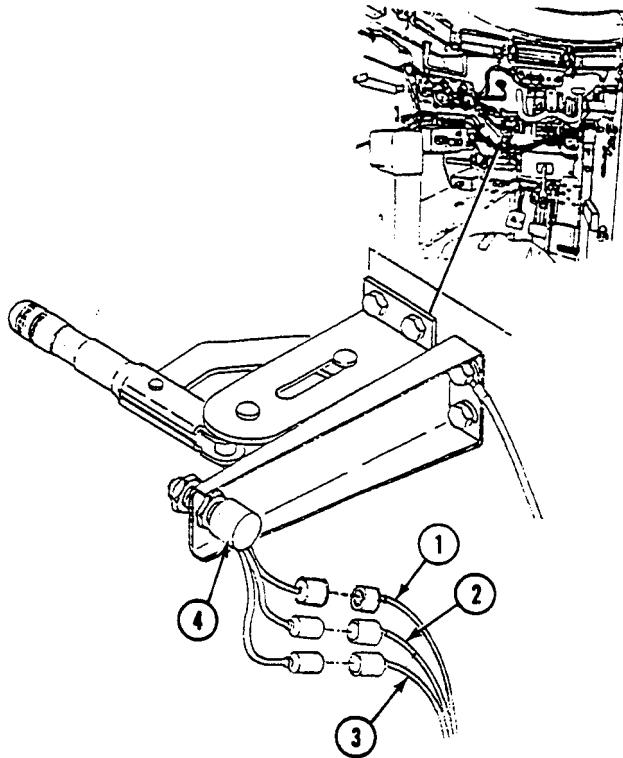

40. Disconnect circuits 27K / 352 plug (5) from engine low coolant level indicator (6) on warning light panel (7).

41. Disconnect circuits 27J / 34 plug (8) from engine low oil pressure indicator (9) on warning light panel (7).

42. Disconnect circuits 27G / 327 plug (10) from transmission high oil temperature indicator (11) on warning light panel (7).

43. Disconnect circuits 25 / 25A plug (12) from horn switch (13) on warning light panel (7).

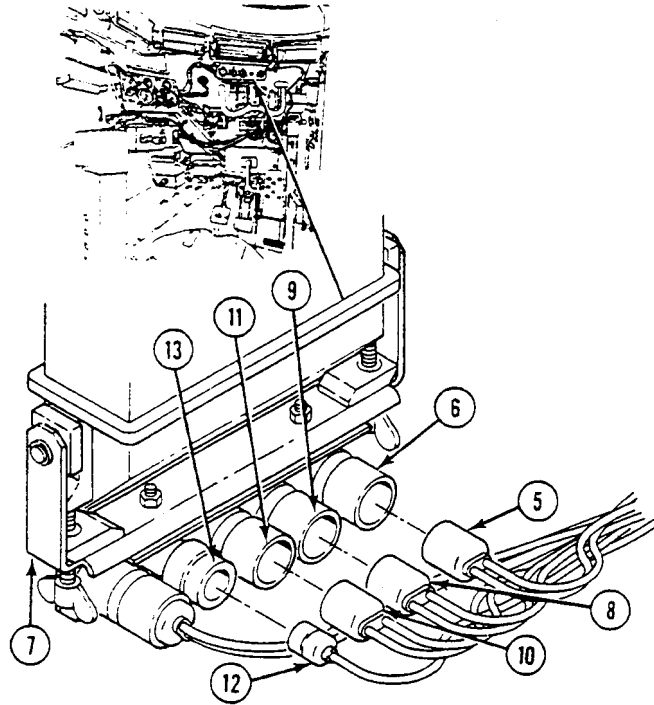

REPLACE FRONT MAIN WIRING HARNESS — Continued

0030 00

44. Disconnect circuits 17 (14) and 18 (15) leads from left service headlight (16).
45. Disconnect circuit 20 lead (17) from left blackout marker light (18).

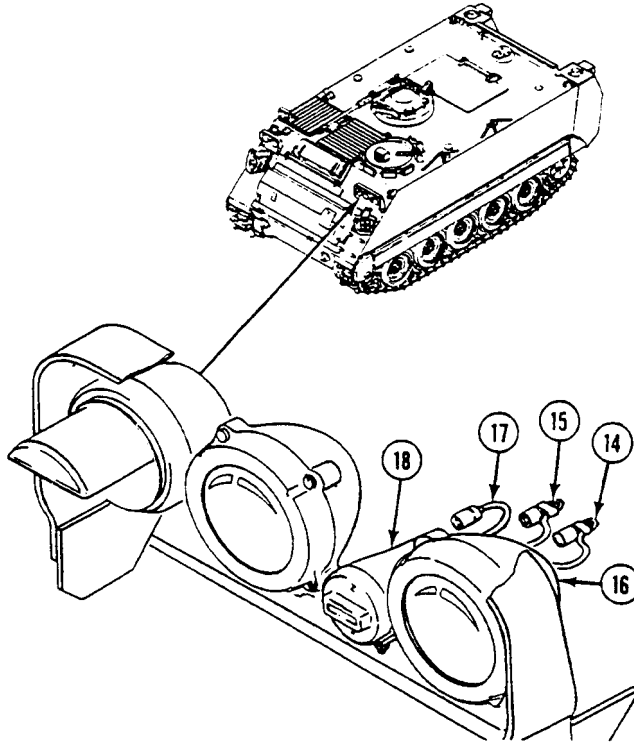

46. Disconnect circuit 19 lead (1) from blackout headlight (2).
47. Remove electrical shell (3), washer (4), and terminal (5) from circuit 19 lead (1).
48. Disconnect circuit 514 (6) and 515 (7) leads from left infrared service headlight (8).

49. Remove five electrical shells (9), sleeves (10), and contacts (11) from leads (12) that were disconnected in Steps 44 - 45 and Step 48. Discard contacts.

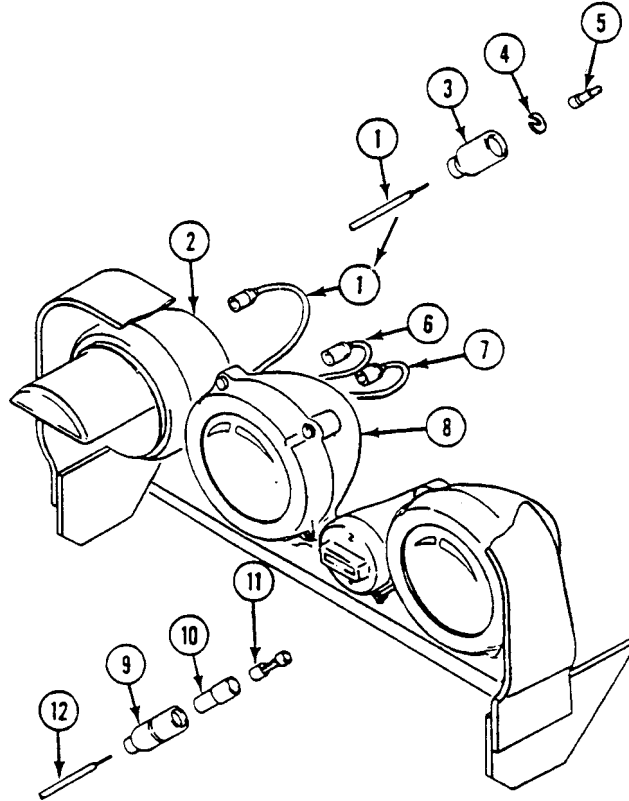

50. Remove nut (13), lockwasher (14), washer (15), and service headlight (8). Discard lockwasher.

51. Remove locknut (16), lockwasher (17), washer (18), and blackout light (2). Discard locknut.

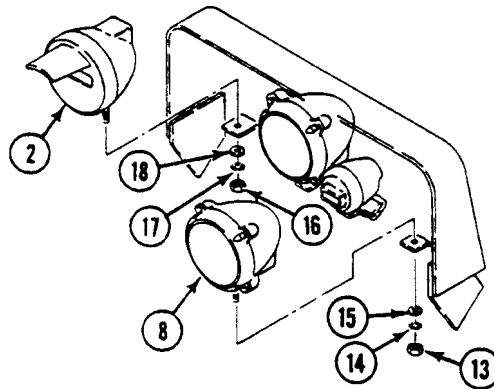

52. Remove two nuts (19), spring washers (20), retainers (21), and bushings (22) that secure wiring harness (23) on front upper nose plate. Pull leads on harness through two bushings.

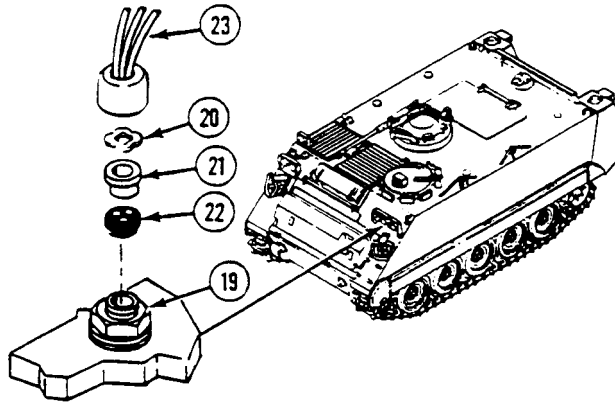

53. Remove four nuts (24), lockwashers (25), washers (26), washers (27), and bushing (28) from front nose plate of hull. Discard lockwashers.

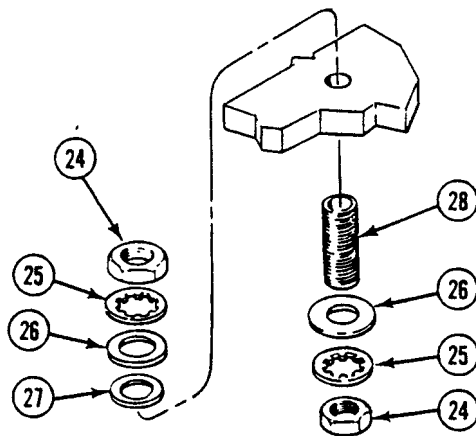

REPLACE FRONT MAIN WIRING HARNESS — Continued

0030 00

54. Remove four screws (1), lockwashers (2), and washers (3) and STE/ICE distribution box (4). Discard lockwashers.

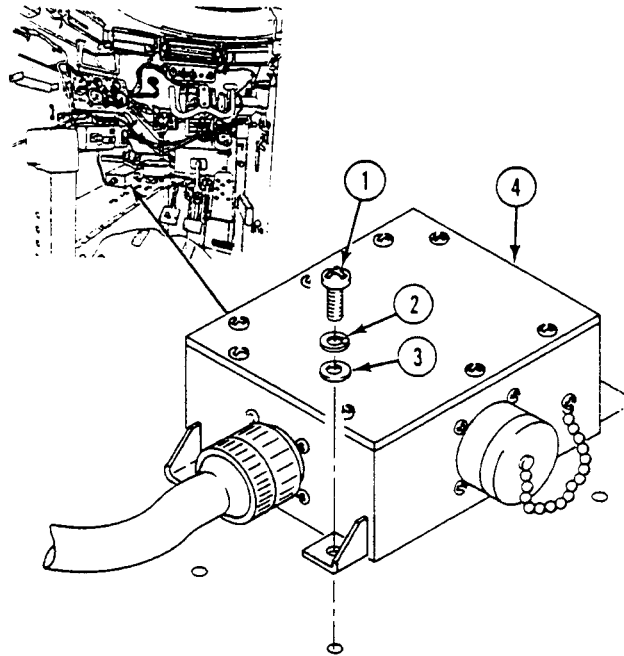

55. Remove three screws (5), lockwashers (6), and clamps (7) from weldnuts (8) behind STE/ICE distribution box. Discard lockwashers.

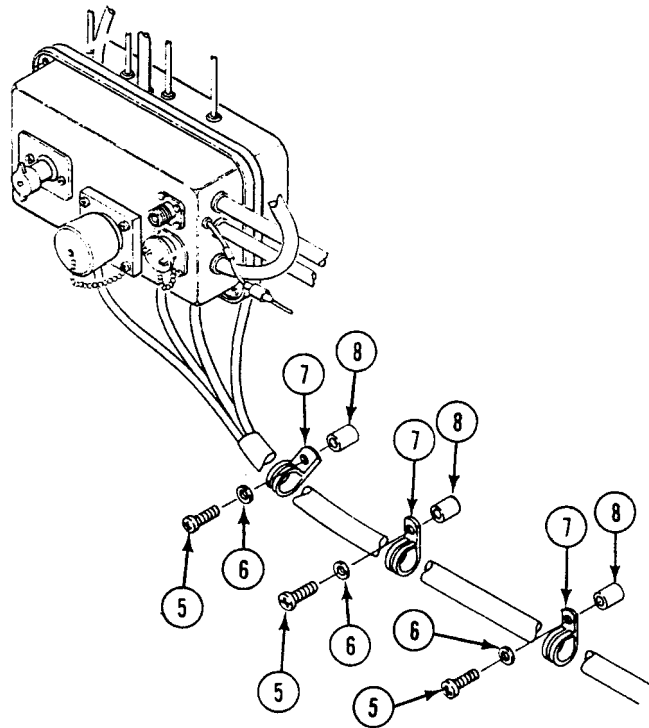

REPLACE FRONT MAIN WIRING HARNESS — Continued**0030 00**

56. Remove screw (9), lockwasher (10), and clamp (11) that secure harness (12) on weldnut (13) near instrument panel (14). Remove wiring harness from weldnut. Discard lockwasher.
57. Remove three tiedown straps (15) from front main wiring harness (12). Remove wiring harness from carrier.

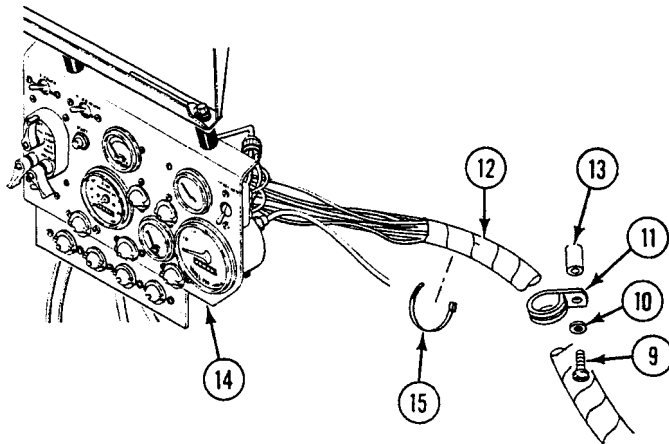
**INSTALLATION**

1. Install harness (12) on weldnut (13) near instrument panel (14). Secure with clamp (11), new lockwasher (10), and screw (9).
2. Install three tiedown straps (15) to harness (12).

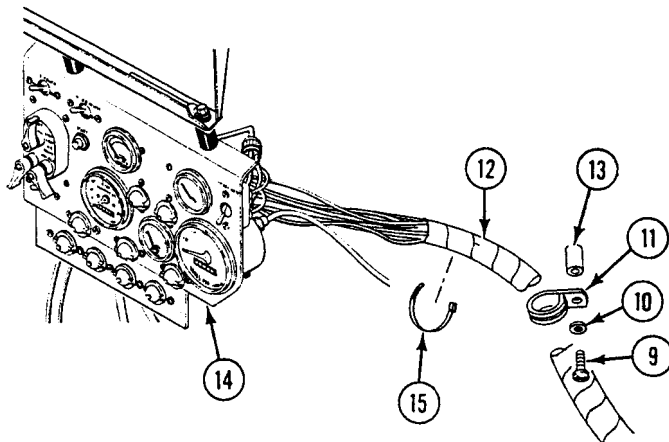

REPLACE FRONT MAIN WIRING HARNESS — Continued

0030 00

3. Install harness (12) on three weldnuts (8) behind STE/ICE distribution box. Secure with three clamps (7), new lockwashers (6), and screws (5).

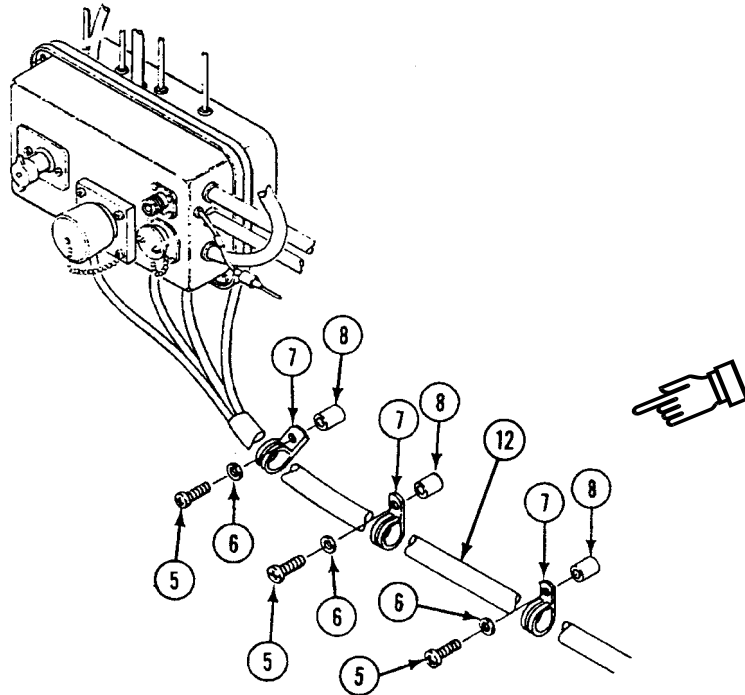

4. Install four screws (1), new lockwashers (2), washers (3), and STE/ICE distribution box (4).

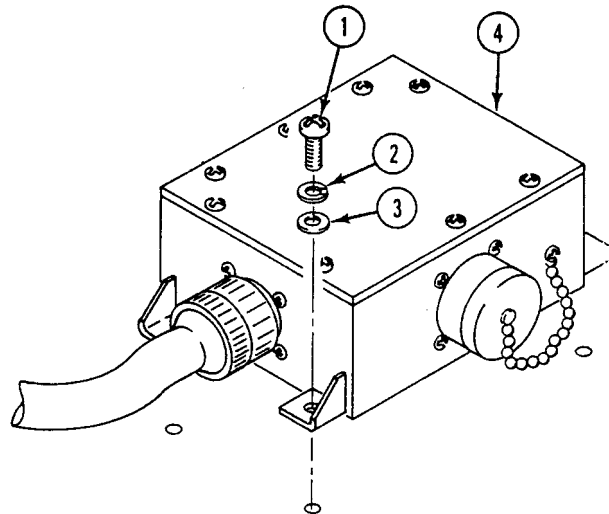

NOTE

Two lead bushings are installed the same way Steps 5 - 6.

5. Install bushing (28) into left bushing hole on front upper nose plate of hull. Secure with washer (26), new lockwasher (25), and nut (24) (from inside of hull), two washers (26)(27), new lockwasher (25), and nut (24) (from outside of hull).

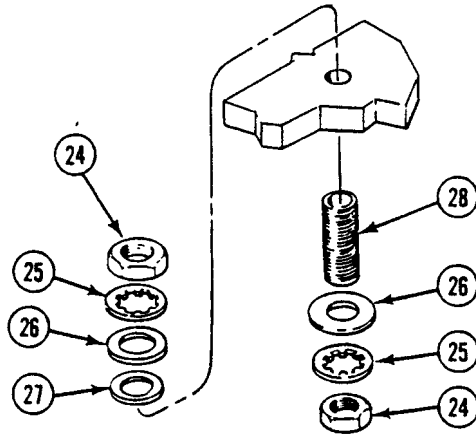

6. Route circuit 17, 18, and 20 leads (6) out through bushing. Install rubber bushing (7), retainer pack (8), spring washer (9) on bushing. Secure with coupling nut (10).

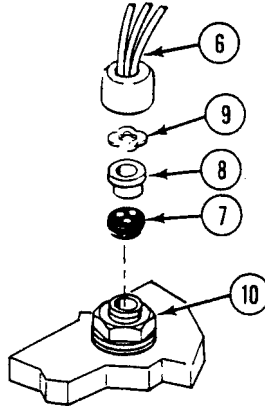

REPLACE FRONT MAIN WIRING HARNESS — Continued

0030 00

7. Install blackout headlight (2) and secure with washer (18), lockwasher (17), and new locknut (16).
8. Install service headlight (8) and secure with washer (15), new lockwasher (14), and nut (13).

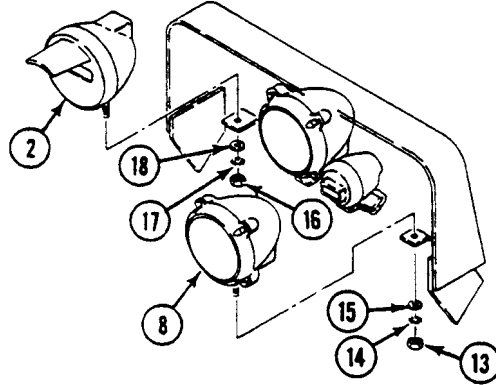

9. Install five electrical shells (19), sleeves (20), and contacts (21) on circuit 17, 18, 20, 514, and 515 leads (22).
10. Connect circuit 17 (23) and 18 (24) leads to left service headlight (15).
11. Connect circuit 20 lead (25) to left blackout marker light (26).

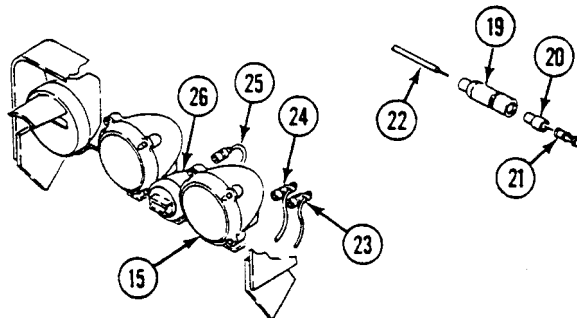

12. Connect circuit 514 (27) and 515 (28) leads to left infrared service headlight (29).
13. Install electrical shell (30), washer (31), and terminal (32) on circuit 19 lead (33).
14. Connect circuit 19 lead (33) to left blackout light (11).

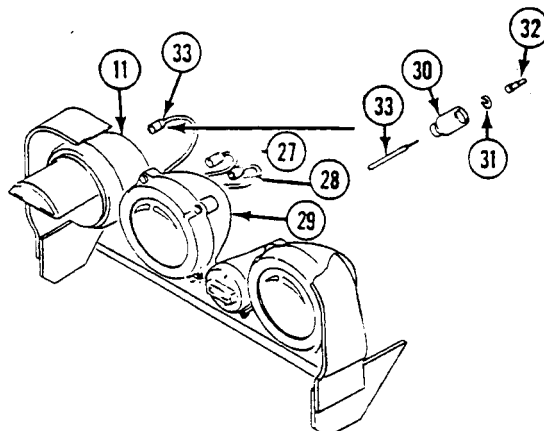

15. Connect circuit 25 / 25A plug (12) to horn switch (13) on warning light panel (7).
16. Connect circuit 27G / 327 plug (10) to transmission high oil temperature indicator (11) on warning light panel (7).
17. Connect circuit 27J / 34 plug (8) to engine low oil pressure indicator (9) on warning light panel (7).
18. Connect circuits 27K / 352 plug (5) to engine low coolant level indicator (6) on warning light panel (7).

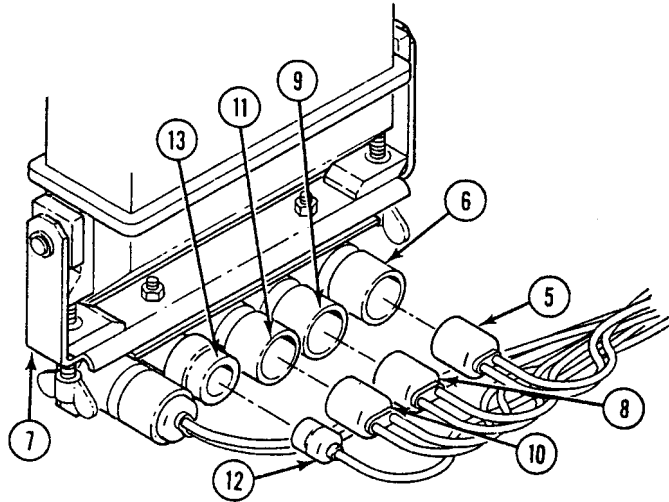

19. Connect circuit 366A (3), 367 (2), and 370 (1) leads to parking brake switch (4).

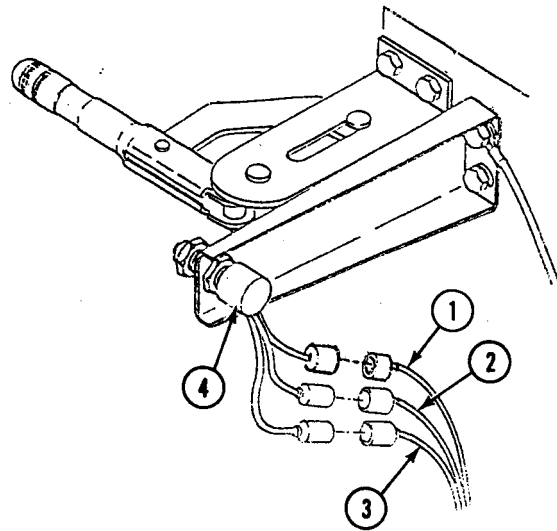

20. Connect circuit 75A (13), 75B (12), 366 (11), 366A (10) leads to stop switch (14).

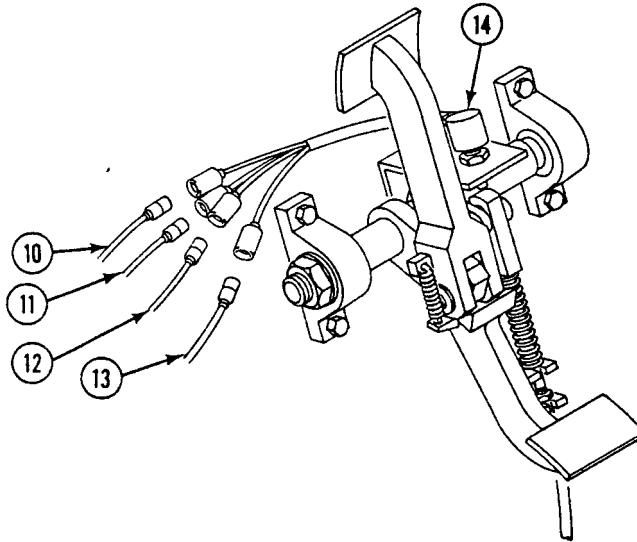

21. Connect connector (19) to dimmer switch (20).
22. Install cover (21) on harness (22). Route harness through cover opening (23) into power plant compartment. Secure cover on driver's compartment bulkhead with four screws (24) and new locknuts (25).

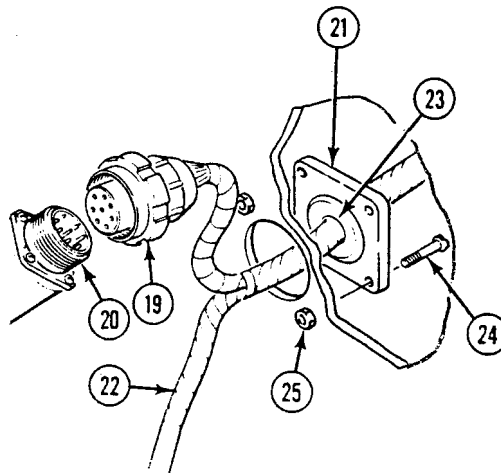

REPLACE FRONT MAIN WIRING HARNESS — Continued

0030 00

23. Slide mount plate (1) between two lower lockwashers (2), two upper lockwashers (3), and screws (4) of voltage regulator (5).
24. Slide two new lockwashers (8), under front mount plate (1) on hull weld nuts. Place two new lockwashers (7) on mount plate (1) over holes. Secure with two screws (6).
25. Tighten two rear screws (4).

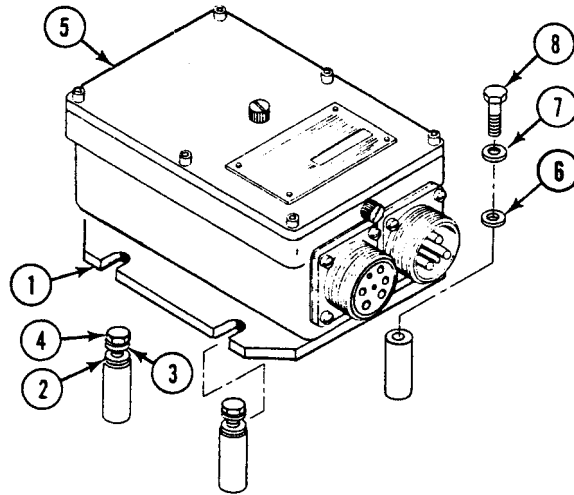

26. From inside of power plant compartment, place harness (4) on driver's bulkhead. Secure with three clamps (3), new lockwashers (2), and screws (1).

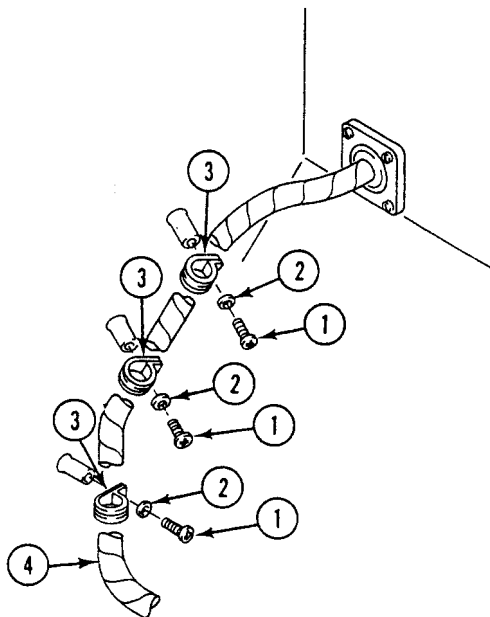

27. Connect circuit 452 lead (9) to front bilge pump (10).

28. Install two screws (5), new lockwashers (6), and four flat washers (7) securing bilge pump strainer (8) to weld nuts.

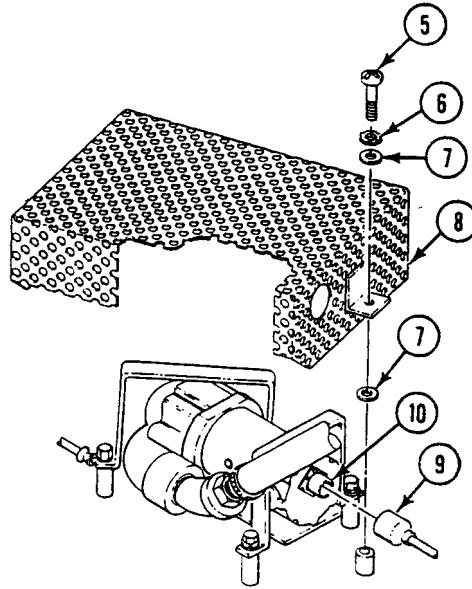

29. Connect circuit 516A lead (19) to infrared power pack (20).

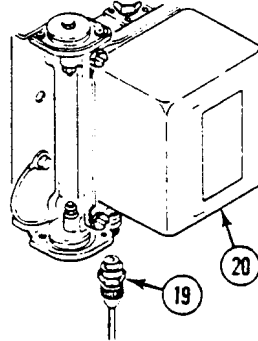

30. Connect two connectors (1) to generator regulator (2).

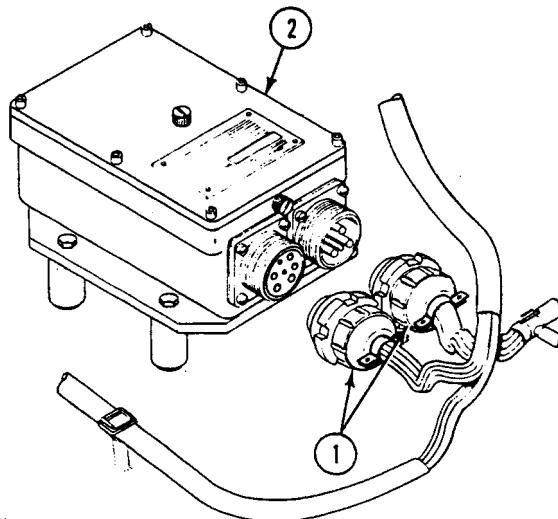

31. Place four connectors (18) on driver's bulkhead. Secure with 16 new locknuts (17) and screws (16).

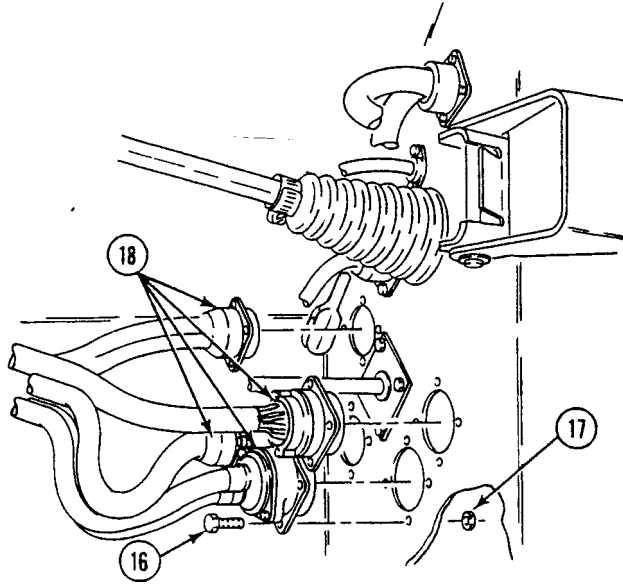

32. From power plant compartment, connect four connectors with right headlight wiring harness (12), generator regulator lead (13), and two power plant harness leads (14)(15) on driver's bulkhead.

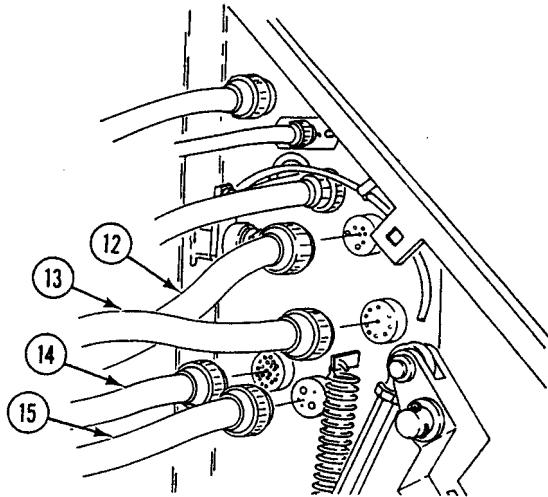

REPLACE FRONT MAIN WIRING HARNESS — Continued

0030 00

33. Place harness (8) on two weldnuts (9). Secure with two clamps (10), new lockwashers (11), and three screws (12) on side plate of hull.

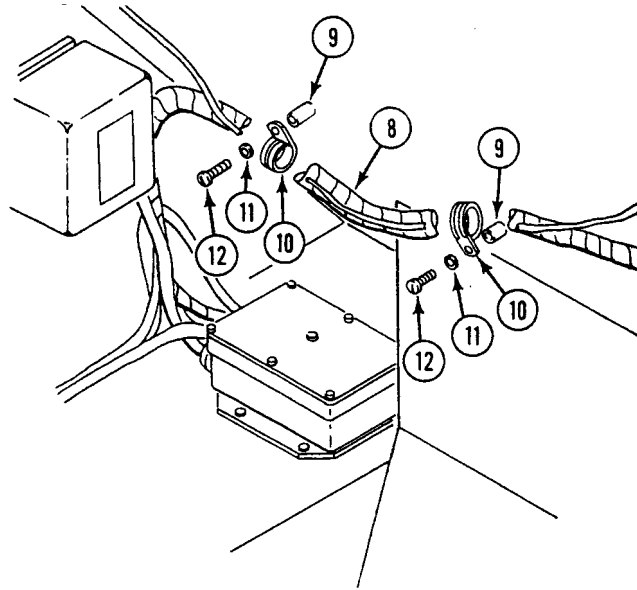

34. Install circuit 6 (3) and 6A (4) leads into distribution box (6). Secure 6 and 6A leads on bus bar (5) with new lockwasher (2) and screw (1).

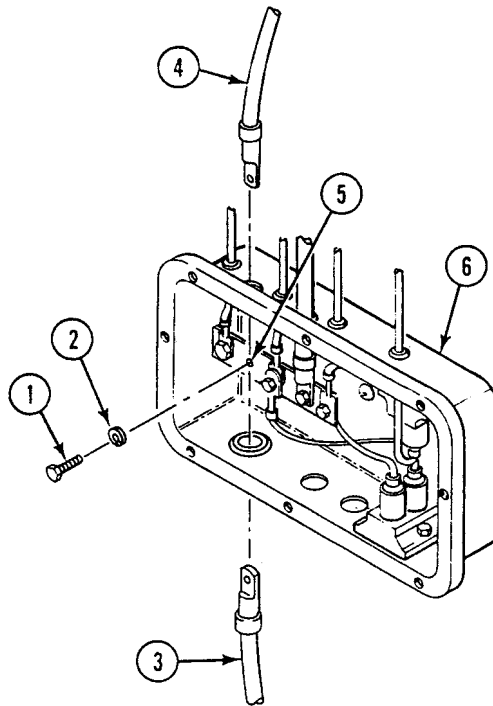

REPLACE FRONT MAIN WIRING HARNESS — Continued

0030 00

35. Install circuits 2 (14), and 2A (20) leads into master switch panel (10) through distribution box (11). Secure circuit 6 (15), 2 (14) and 400 (16) on conductor bus (17) with new locknut (12), and screw (13). Secure circuit 2A (20) lead on conductor bus (17) with lockwasher (19) and nut (18).

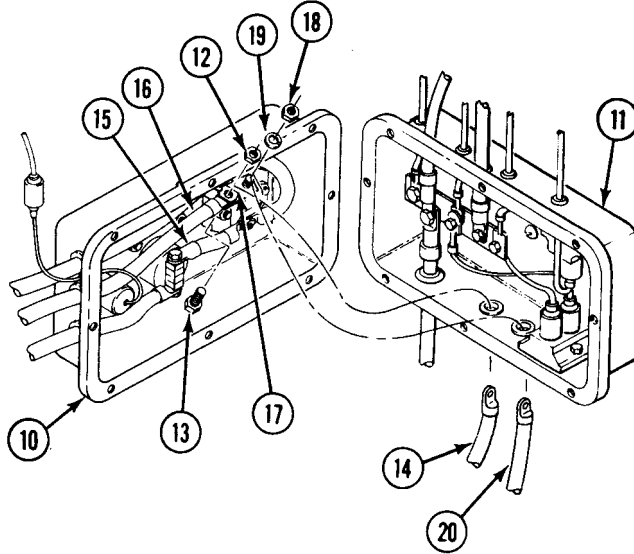

36. Install master switch panel (10) on distribution box (11) with eight screws (9), washers (8), and new locknuts (7).

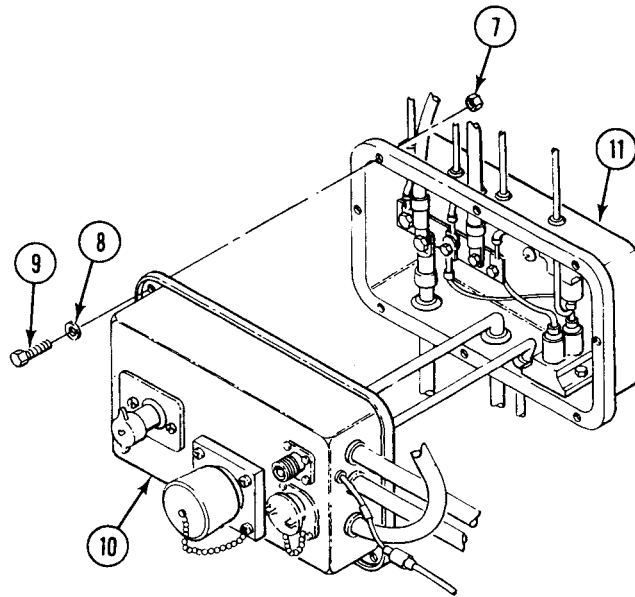

REPLACE FRONT MAIN WIRING HARNESS — Continued

0030 00

37. Place harness (5) into instrument panel (6).

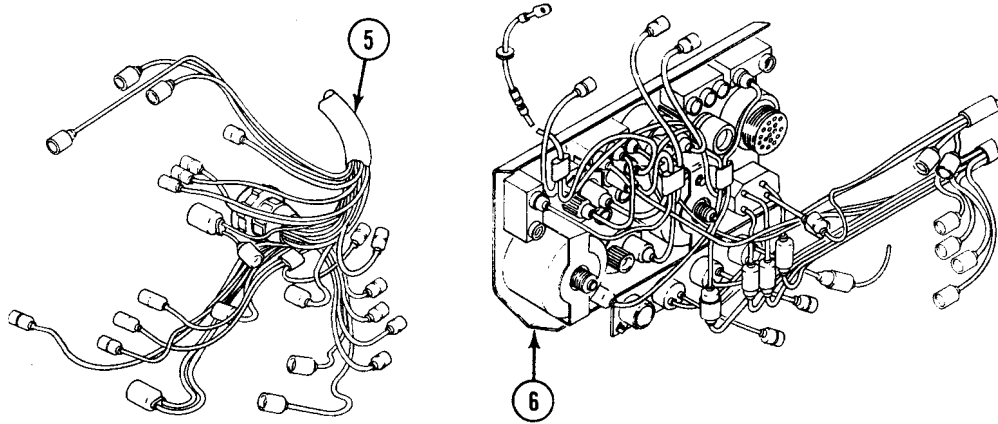

38. Connect circuit 370 lead (17) to connector (18).

39. Connect circuit 367 lead (19) to transmission low oil pressure indicator connector (20).

40. Connect circuits 519 and 519A lead (21) to headlights high beam indicator (22).

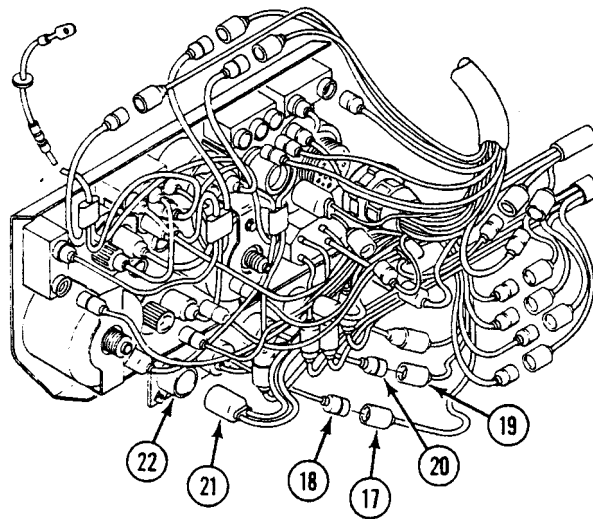

41. Connect circuits 514 and 515 lead (14) to infrared (I.R.) B.O. selector switch (12).
42. Connect circuit 19 lead (11) to infrared (I.R.) B.O. selector switch (12).
43. Connect circuit 520 lead (13) to infrared (I.R.) B.O. selector switch (12).

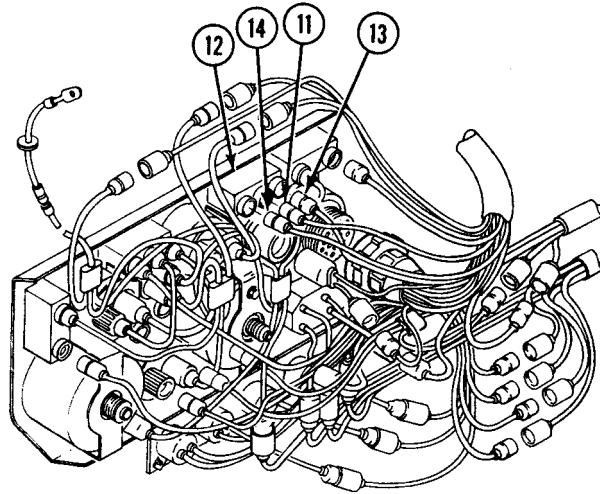

44. Connect circuit 406 lead (9) to air box heater switch (10).
45. Connect circuit 33 lead (7) to engine coolant temperature gage (8).

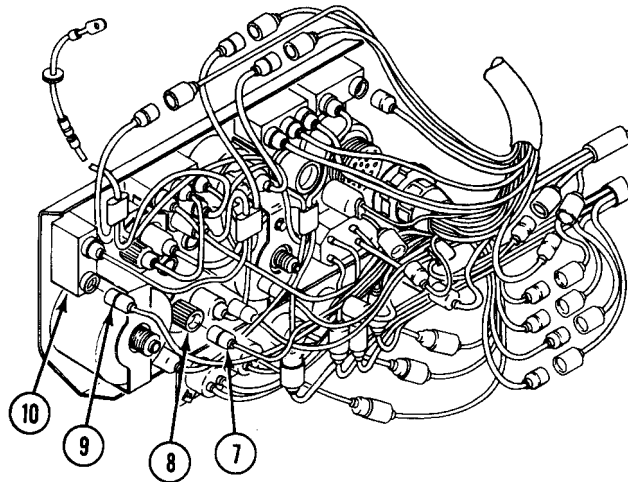

REPLACE FRONT MAIN WIRING HARNESS — Continued

0030 00

46. Connect circuit 74 / 14 leads (9) to starter switch (10).
47. Connect circuit 516A lead (11) to infrared (I.R.) power pack switch (12).
48. Connect circuits 15 (13), 25A (14), 27F (15) and 14 (16) leads to instrument panel wiring harness connectors.

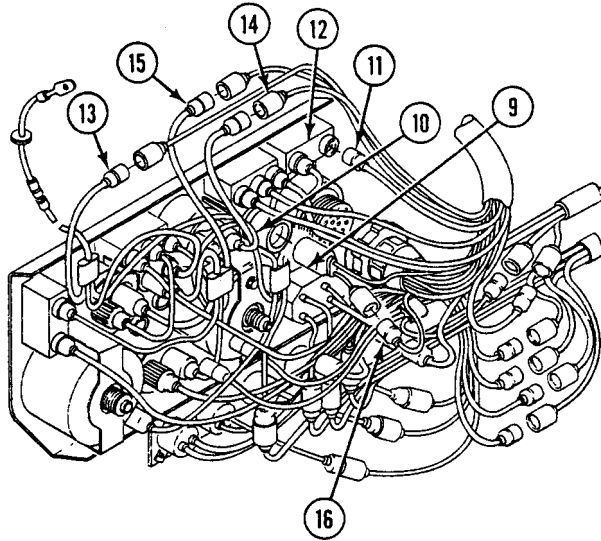

49. Connect three circuit 40 leads (12) to two instrument panel lights (13) and transmission control wiring harness connector (14).
50. Connect circuit 366 (15) to circuit 366 (16).

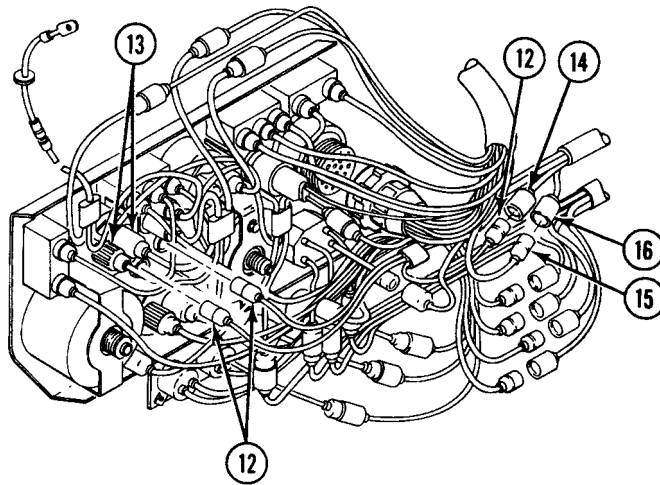

REPLACE FRONT MAIN WIRING HARNESS — Continued

0030 00

51. Connect circuit 452B lead (10) to bilge pump ON indicator light (11).

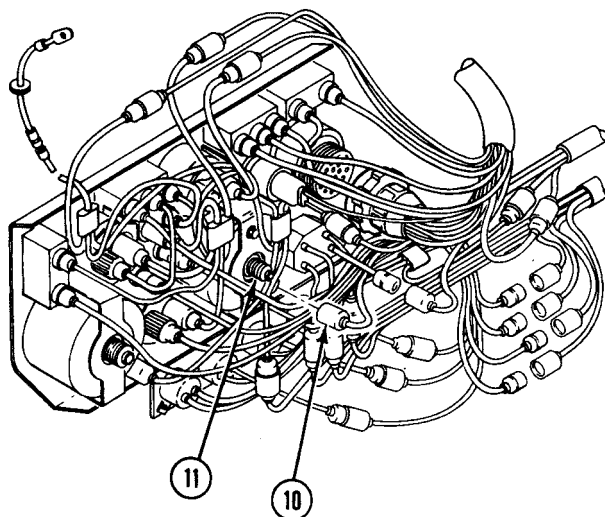

52. Connect circuit 452A lead (8) to bilge pump switch (9).
53. Connect connector (6) to light selector switch (7).
54. Connect circuits 24 (1), 23 (2), 22 (3), and 21 (4) leads to rear main wiring harness (5).

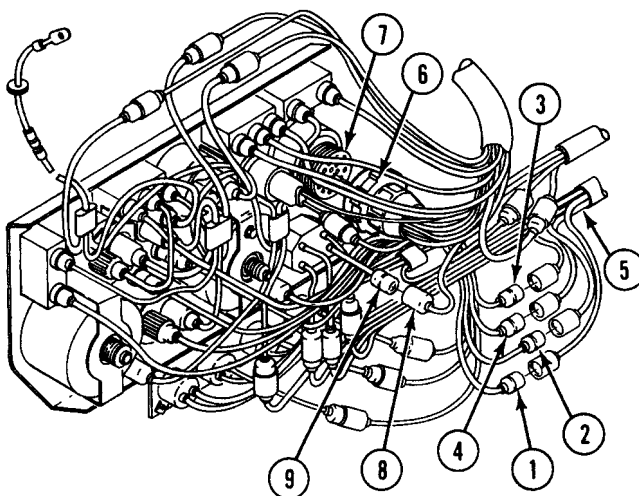

55. Install WAIT indicator (15) with lockwasher (16) in instrument panel (5) and secure with knurled nut (14) (glow plug system only).
56. Place instrument panel (5) on two struts.
57. Install ground lead (11), WAIT indicator ground lead (17) (glow plug system only), and new lockwasher (10) on upper support (12).

REPLACE FRONT MAIN WIRING HARNESS — Continued

0030 00

58. Install panel (5) with two mounts (13) on support (12). Secure with two screws (8) and new lockwashers (9).

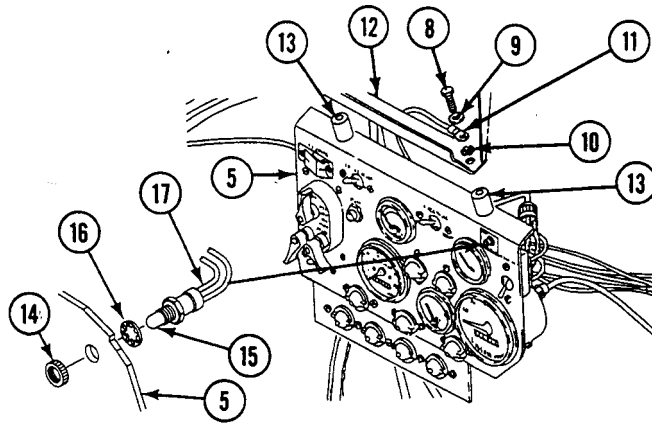

59. Install panel (12) on two struts (13) and (14). Secure with two nuts (15), mounts (16), washers (17), and screws (18).

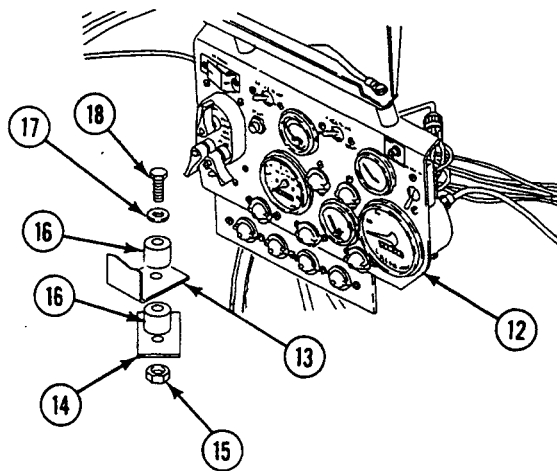
**FOLLOW-THROUGH STEPS**

1. Connect battery ground strap (see your -20)
2. Close power plant front access door (see your -10)
3. Raise power plant access cover (see your -10)
4. Raise trim vane (see your -10)
5. Start engine (see your -10)
6. Check that master switch panel, instrument panel, distribution box, and lights work right (see your -10)
7. Stop engine (see your -10)
8. Turn MASTER SWITCH to OFF (see your -10)

END OF TASK

REPAIR FRONT MAIN WIRING HARNESS

0031 00**THIS WORK PACKAGE COVERS:**

Repair or Replacement (page 0031 00-1).

INITIAL SETUP:Maintenance Level

Direct Support

Personnel Required

Fuel and Elec Sys Rep 63G10

Tools and Special ToolsAutomotive Fuel and Electrical System Repair Tool Kit
(WP 0120 00, Item 59)

Electrical Connector Tool Kit (WP 0120 00, Item 60)

Digital Multimeter (WP 0120 00, Item 38)

References

See your -20

Materials/Parts

Insulation tape (WP 0122 00, Item 19)

Equipment ConditionFront main wiring harness assembly removed
(WP 0030 00)

REPAIR OR REPLACEMENT

1. Perform continuity check on front main wiring harness assembly to determine which parts require repair or replacement. Use multimeter.
2. Repair connector(s) as required (WP 0026 00).
3. Repair terminals as required (see your -20).
4. Repeat continuity check on front main wiring harness assembly to ensure that repairs have been completed.
5. Use insulation tape to bind wiring harness.

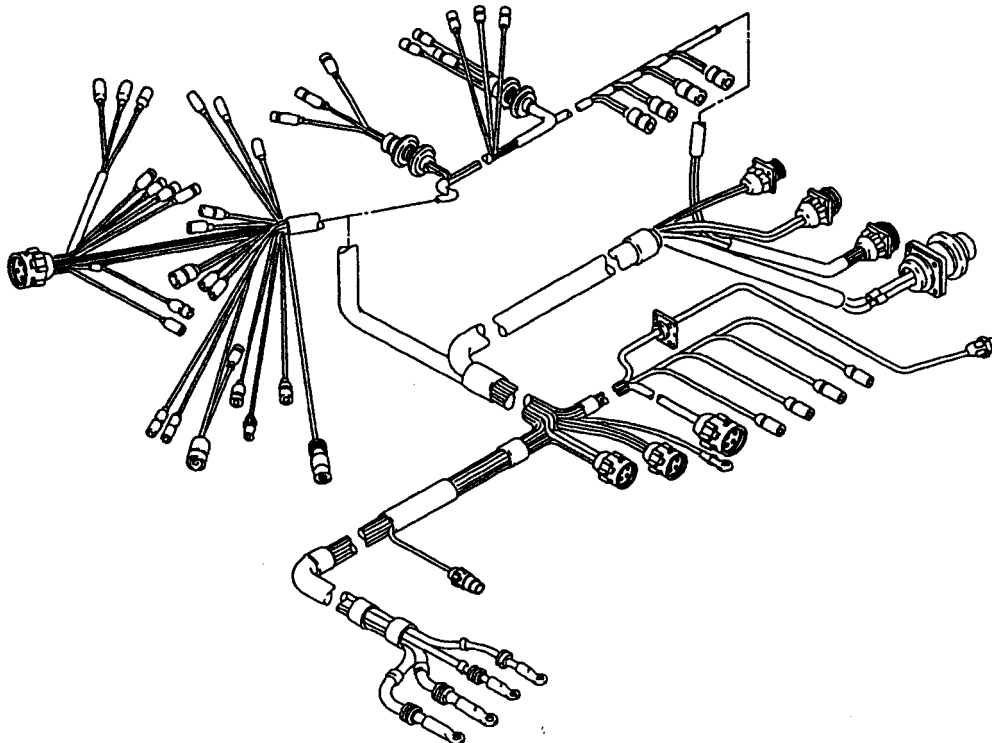

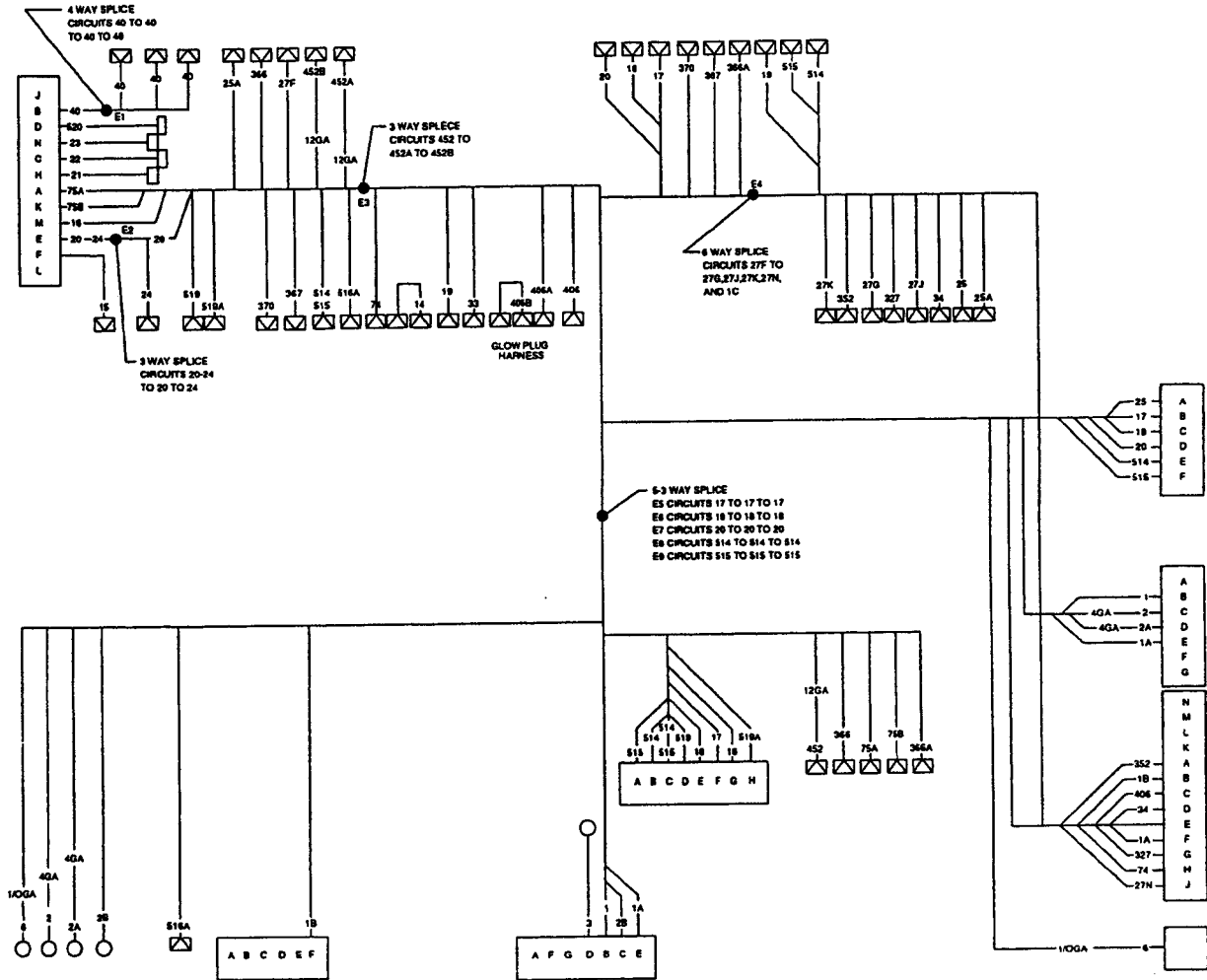

FOLLOW-THROUGH STEPS

1. Install front main wiring harness assembly (WP 0030 00).

END OF TASK

**REPAIR SMOKE GRENADE LAUNCHER WIRING HARNESS
(M113A3 AND M1059A3 ONLY)**

0033 00

THIS WORK PACKAGE COVERS:

Repair or Replacement (page 0033 00-1).

INITIAL SETUP:

Maintenance Level

Direct Support

Personnel Required

Fuel and Elec Sys Rep 63G10

Tools and Special Tools

Automotive Fuel and Electrical System Repair Tool Kit
(WP 0120 00, Item 59)

Electrical Connector Tool Kit (WP 0120 00, Item 60)

Digital Multimeter (WP 0120 00, Item 38)

References

See your -20

Equipment Condition

Smoke grenade wiring harness assembly removed (see your -20)

Materials/Parts

Insulation tape (WP 0122 00, Item 19)

REPAIR OR REPLACEMENT

1. Perform continuity check on smoke grenade launcher wiring harness assembly to determine which parts require repair or replacement.
2. Repair connector as required WP 0026 00.
3. Repair leads and/or small connector as required (see your -20).
4. Repeat continuity check on engine wiring harness assembly to ensure that repairs have been completed.
5. Use insulation tape to bind wiring harness.

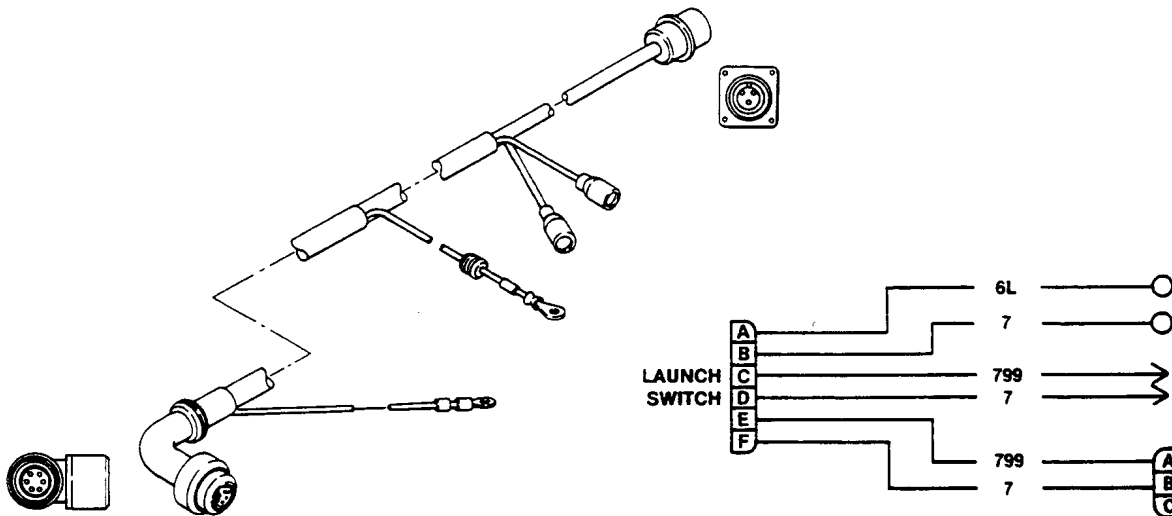

FOLLOW-THROUGH STEPS

1. Install smoke grenade launcher wiring harness assembly (see your -20).

END OF TASK

REPAIR STEERING LOCK SWITCH WIRING HARNESS

0034 00

THIS WORK PACKAGE COVERS:

Repair or Replacement (page 0034 00-1).

INITIAL SETUP:

Maintenance Level

Direct Support

Personnel Required

Fuel and Elec Sys Rep 63G10

Tools and Special Tools

- Automotive Fuel and Electrical System Repair Tool Kit (WP 0120 00, Item 59)
- Electrical Connector Tool Kit (WP 0120 00, Item 60)
- Digital Multimeter (WP 0120 00, Item 38)

References

See your -20

Materials/Parts

- Insulation tape (WP 0122 00, Item 19)

Equipment Condition

Steering lock switch wiring harness removed (see your -20)

REPAIR OR REPLACEMENT

1. Perform continuity check on steering lock switch wiring harness assembly to determine which parts require repair or replacement.
2. Repair connector as required (WP 0026 00).
3. Repair terminals as required (see your -20).
4. Repeat continuity check on steering lock switch wiring harness assembly to ensure that repairs have been completed.
5. Use insulation tape to bind wiring harness.

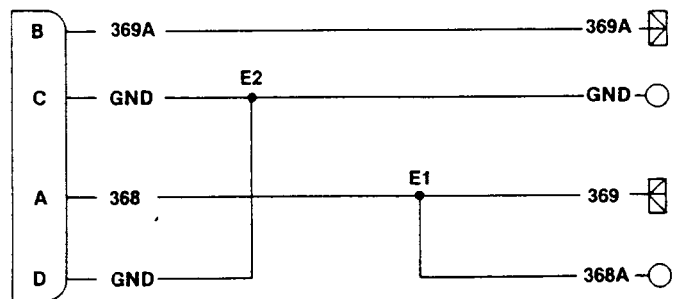
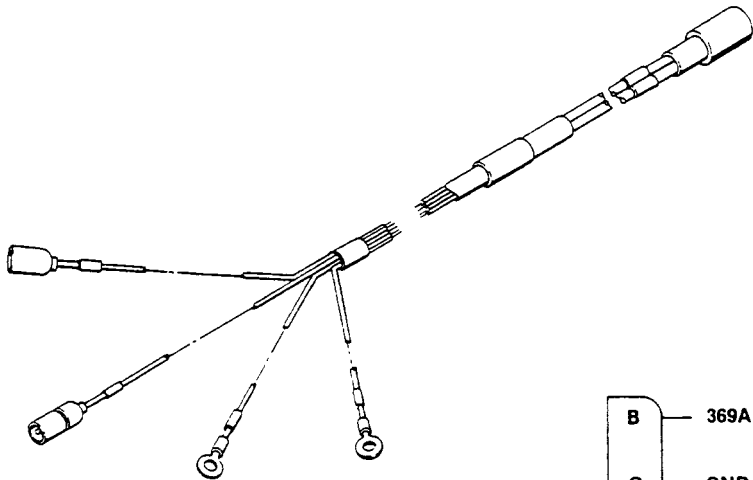

FOLLOW-THROUGH STEPS

1. Install steering lock switch wiring harness assembly (see your -20).

END OF TASK

CHAPTER 7

DIRECT SUPPORT MAINTENANCE INSTRUCTIONS
FOR TRANSMISSION

WORK PACKAGE INDEX

<u>Title</u>	<u>Sequence No.</u>
REPLACE TRANSMISSION.....	0035 00

REPLACE TRANSMISSION

0035 00

THIS WORK PACKAGE COVERS:

Removal (page 0035 00-2).
 Installation (page 0035 00-11).

INITIAL SETUP:

Maintenance Level

Direct Support

Tools and Special Tools

General Mechanic's Tool Kit (WP 0120 00, Item 62)
 Engine and Transmission Sling (WP 0120 00, Item 52)
 Adjustable Wrench (WP 0120 00, Item 70)
 Torque Wrench, 1/2 inch drive (WP 0120 00, Item 73)
 Torque Wrench, 1/2 inch drive (WP 0120 00, Item 74)
 Torque Wrench, 1/2 inch drive (WP 0120 00, Item 75)
 Lifting device with rated lift capability of at least 1,700
 lb (772 kg)

Materials/Parts

Antiseize compound (WP 0122 00, Item 5)
 Sealing compound (WP 0122 00, Item 25)
 Block (2)
 Gasket
 Locknut
 Locknut (2)
 Locknut (2)

Lockscrew

Preformed packing
 Self-locking bolt (11)
 Tie down strap (2)

Personnel Required

Track Vehicle Repairer 63H10

References

See your -10
 See your -20
 TM 9-2520-272-34&P

Equipment Condition

Power plant removed (see your -20)
 Power plant on maintenance stand (WP 0068 00)
 Transmission oil drained (see your -20)
 Dipstick and filler tube removed (see your -20)
 Transmission oil sampling valve removed (see your -20)
 Ramp hydraulic pump removed (see your -20)

REMOVAL

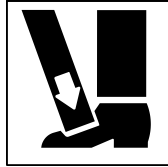
WARNING

The engine support could fall and injure you. Make sure to secure engine support to the main frame before towing, lifting or transporting engine stand.

CAUTION

Engine jack screw could be damaged if the two screws and nuts attaching the jack screw to the main frame are not removed. Remove the screws and nuts before towing, lifting or transporting an empty engine stand.

Contamination of fuel, oil, and coolant lines or fittings can damage equipment. Make sure to cap or cover fuel, oil, and coolant lines or fittings which are to be removed.

1. Disconnect transmission inlet hose (1) from elbow (2).

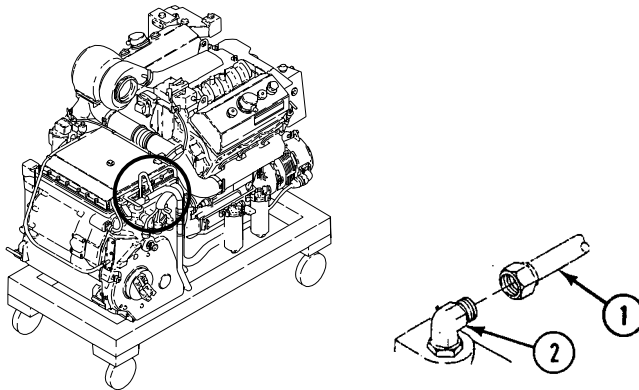

2. Remove screw (1), two washers (2), locknut (3), and inlet hose clamp (4) from transmission mount bracket (5). Discard locknut.
3. Remove screw (6), washer (7), and bracket (5) from transmission.

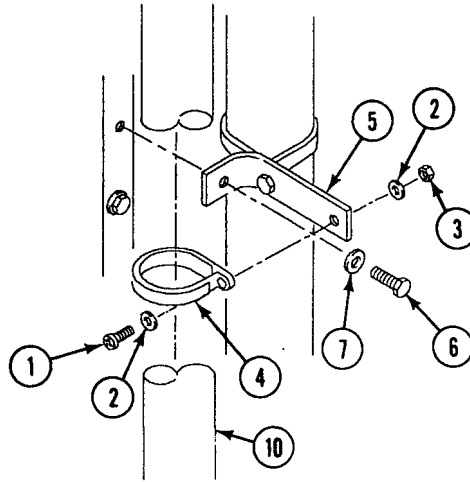

4. Remove two tie down straps (8) from engine wiring harness (9). Discard tie down straps.

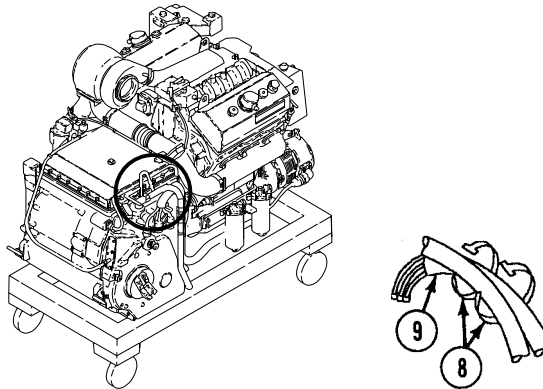

5. Pull inlet hose (10) from under power plant to oil cooler housing side.
6. Remove transmission oil inlet hose (10) from oil cooler outlet elbow (11).

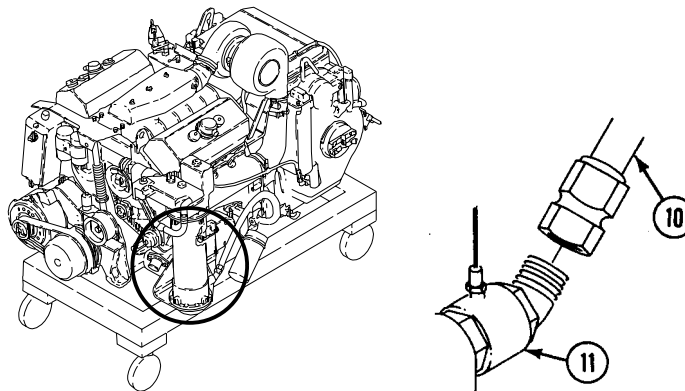

7. Remove self-locking bolt (12), mounting clamp (13), and TV modulator (14) from transmission. Discard self-locking bolt.

8. Remove elbow (15) and pipe plug (16) from transmission.
9. Remove pipe plug (16) from elbow (15), and reinstall plug into throttle valve modulator pressure port.

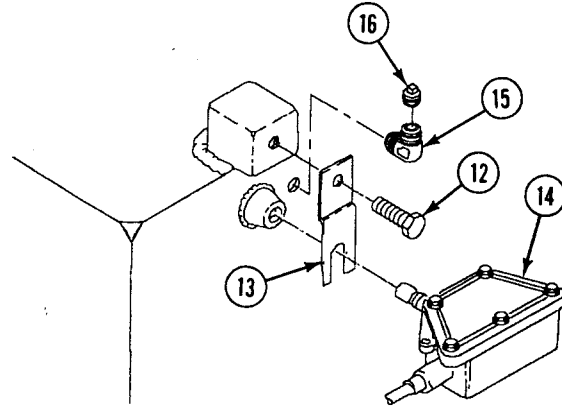

10. Remove screw (1), washer (2), and steering lever (3) from transmission.

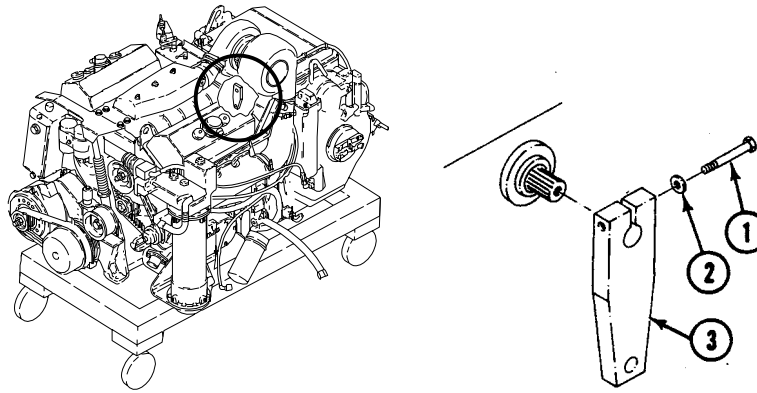

11. Disconnect circuit 34 lead (4) from engine oil low pressure switch (5).

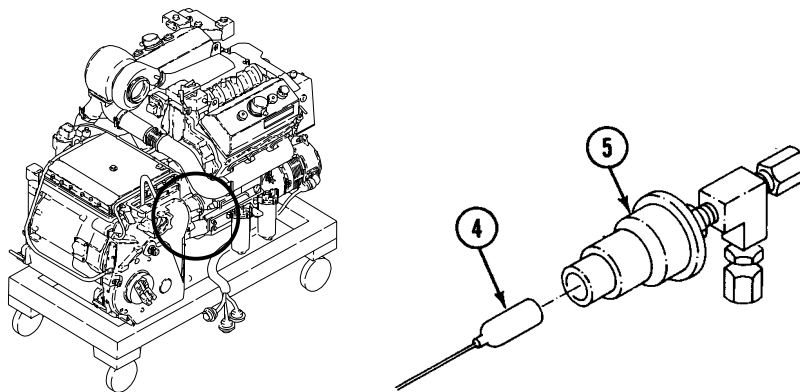

12. Loosen transmission drain tube mount clamp (6) and disconnect drain tube (7) from transmission adapter (8) and slide drain tube forward.

13. Remove nut (9), transmission drain adapter (8), and preformed packing (10) from transmission. Discard preformed packing.

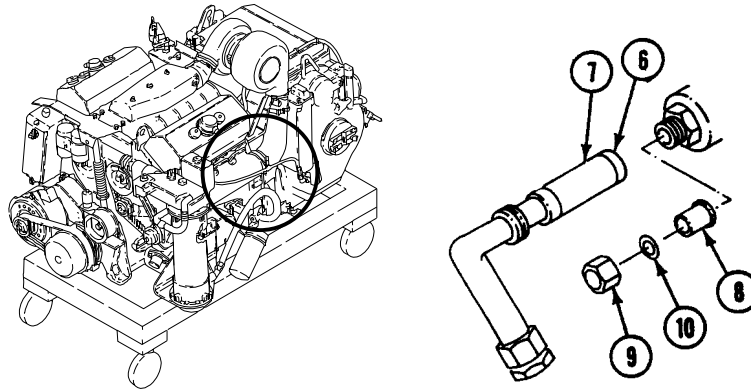

14. Disconnect variable speed drive clutch return hose (11) from elbow (12) on transmission end cover (13).

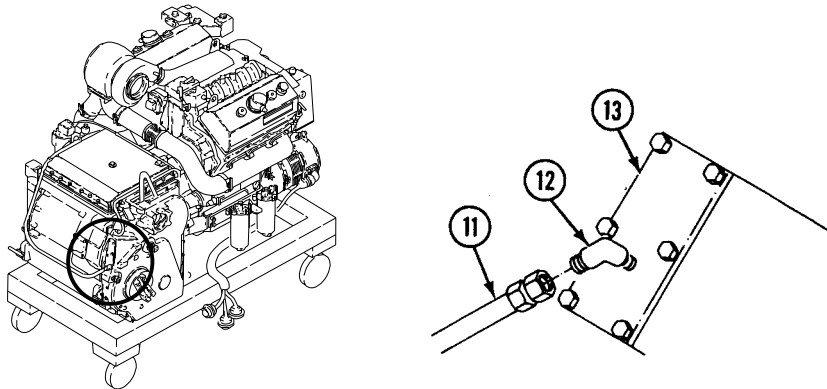

15. Loosen locknut on elbow and transmission oil outlet hose (1) enough to loosen hoses on other side of power unit.

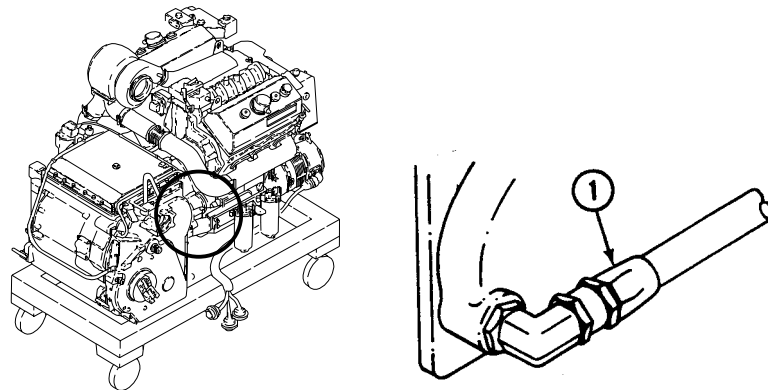

16. Loosen hoses to access self-locking bolts. Remove 10 self-locking bolts (3), 10 washers (4), two locknuts (5), three washers (6), and screw (7) that secure transmission to engine. Discard self-locking bolts and locknuts.

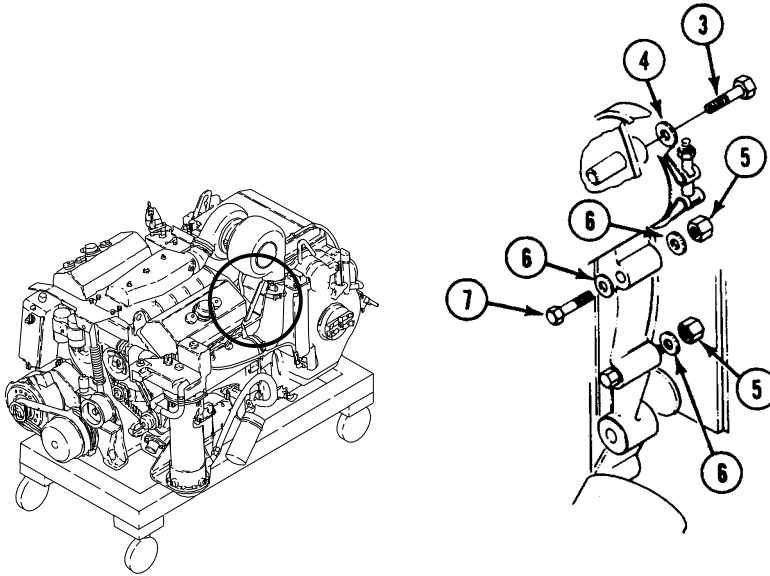

17. Remove two screws (8), washers (9), locknuts (10), and variable speed clutch return hose clamps (11) from brackets (12). Discard locknuts.
18. Remove two screws (13), washers (14), and brackets (12) from transmission.

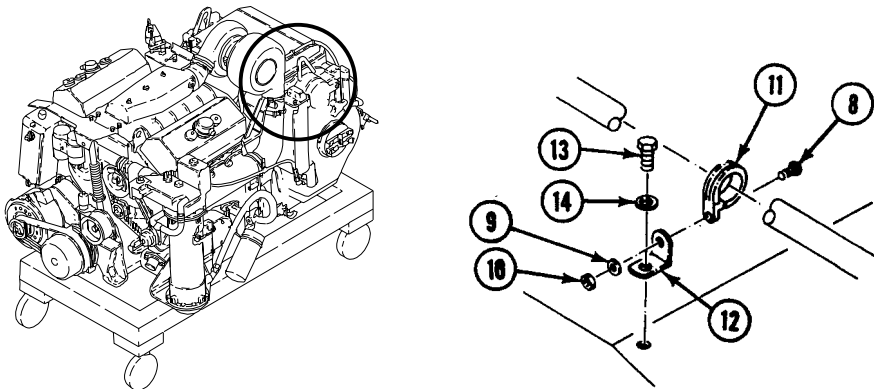

19. Separate transmission (3) from engine (1).

20. Attach sling (2) to transmission.

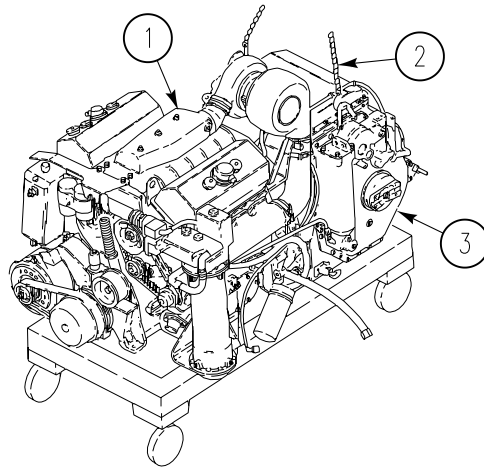

21. Remove transmission (2) from power plant stand and set on two blocks (3). Remove sling (1).

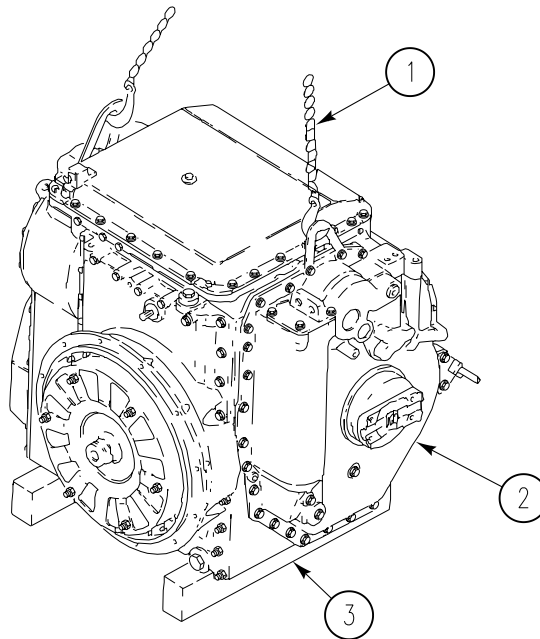

22. Disconnect transmission oil outlet hose (4) from elbow (5). Loosen jam nut (6) and remove elbow (5) from transmission.

23. Remove variable speed drive hose return elbow (7) from transmission end cover (8).

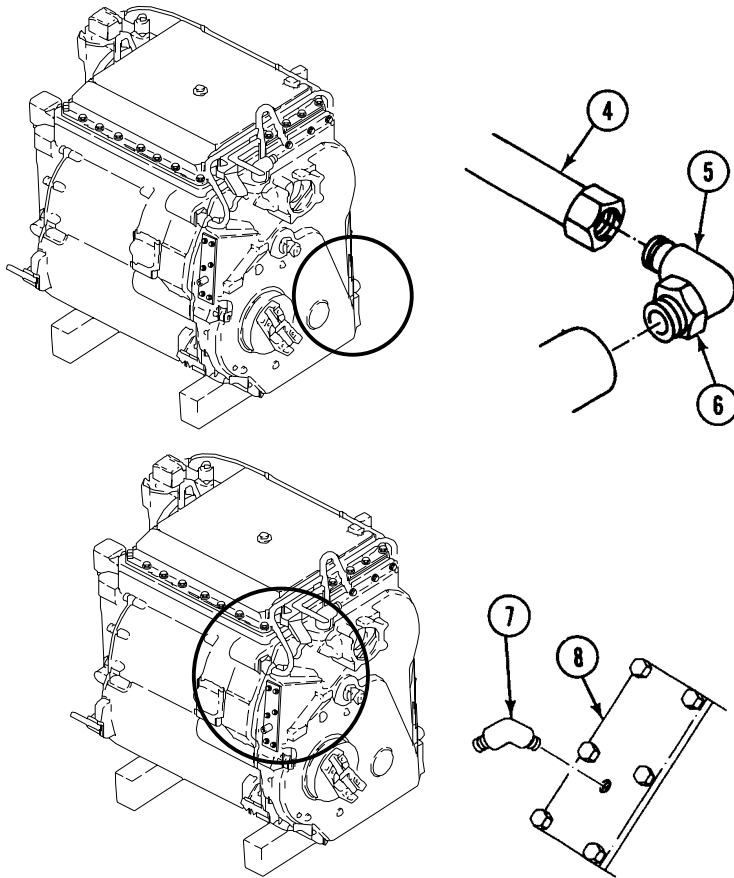

24. Disconnect variable speed drive clutch supply hose (9) from elbow (10) on transmission filter case.
 25. Remove elbow (10) from transmission.

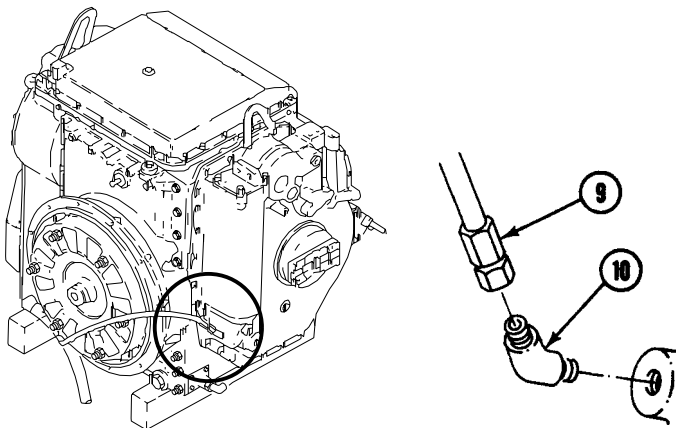

26. Remove four screws (11), dipstick tube adapter (12), and gasket (13) from transmission. Discard gasket.

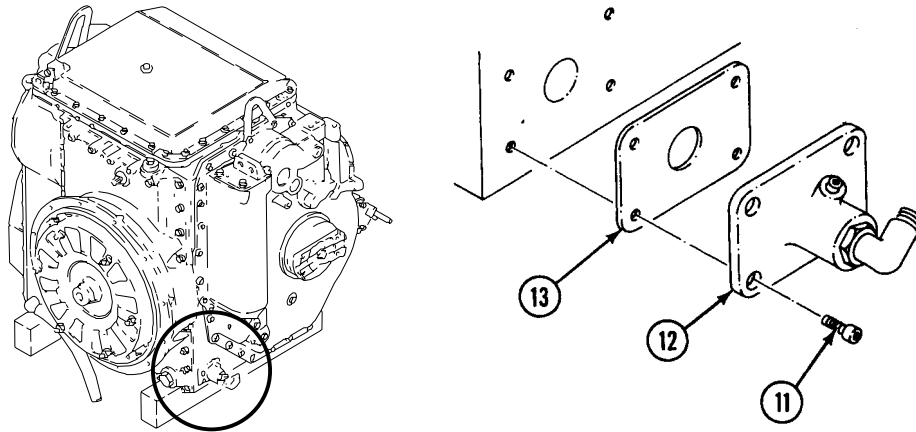

27. Remove two screws (1), washers (2), tow start control lever (3), and mounting bracket (4) from transmission.

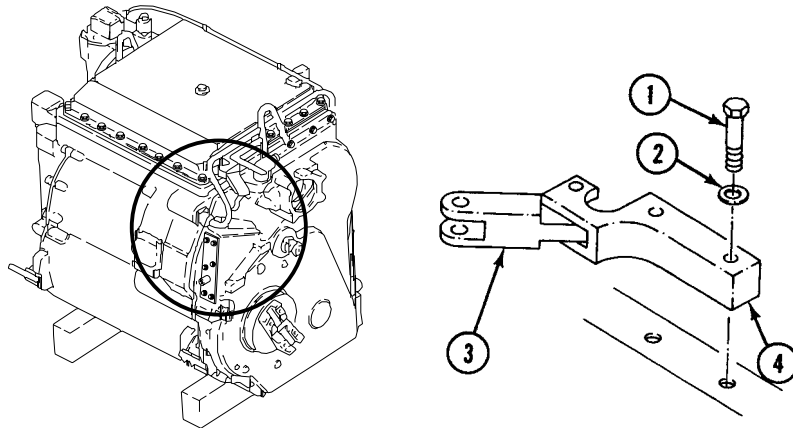

28. Remove four screws (5), washers (6), and wiring harness brackets (7) from transmission.

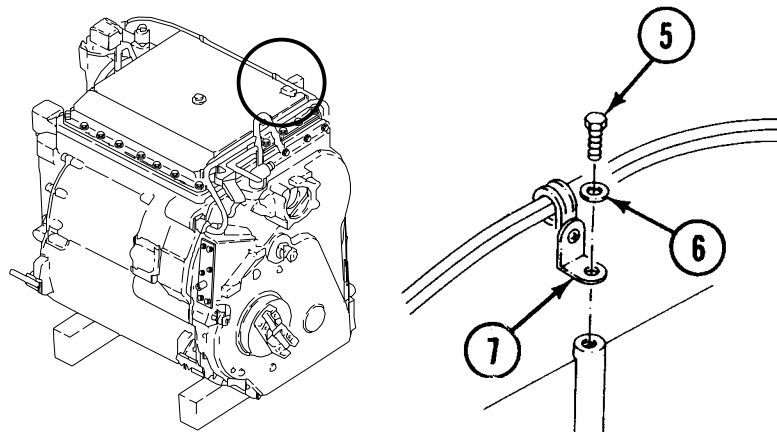

29. Disconnect front connector (8) and rear connector (9) on transmission and remove transmission wiring harness (10).

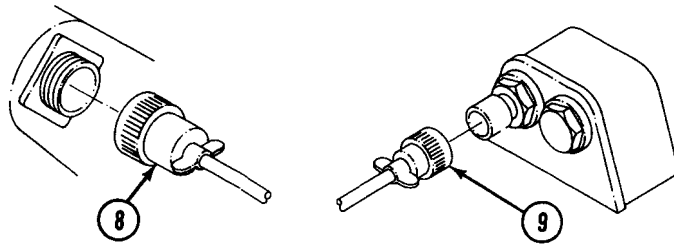
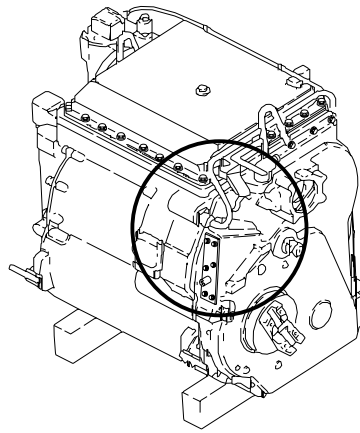

30. Remove six screws (11), washers (12), and end cover (13) from right rear of transmission.

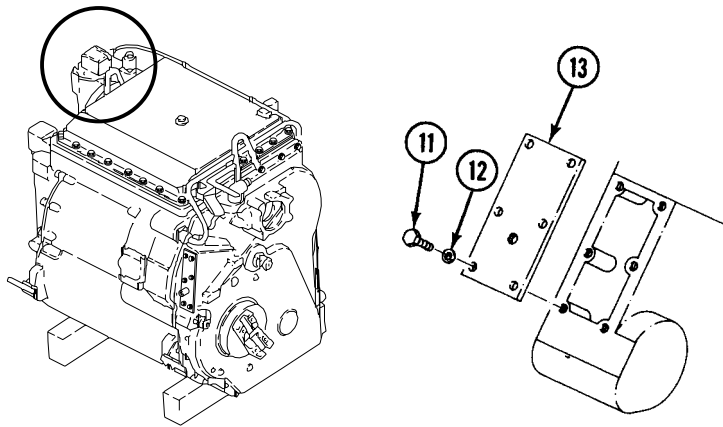

INSTALLATION

1. Remove transmission from shipping container. See (TM 9-2520-272-34&P). Set transmission on two blocks (1).

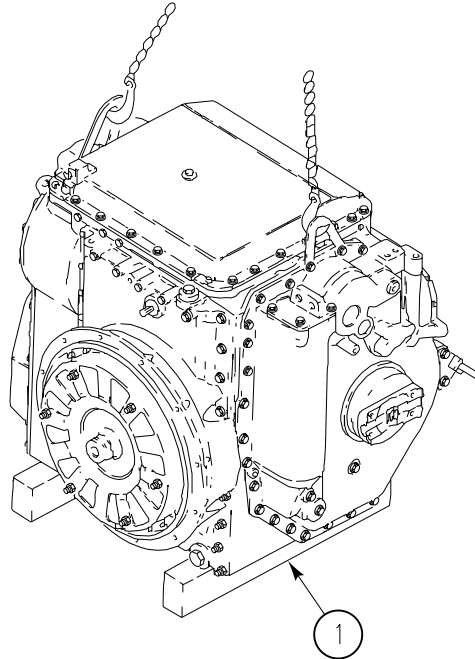

2. Clean engine flywheel grooves (22) and transmission splined coupling grooves (23). Apply antiseize compound to splines.

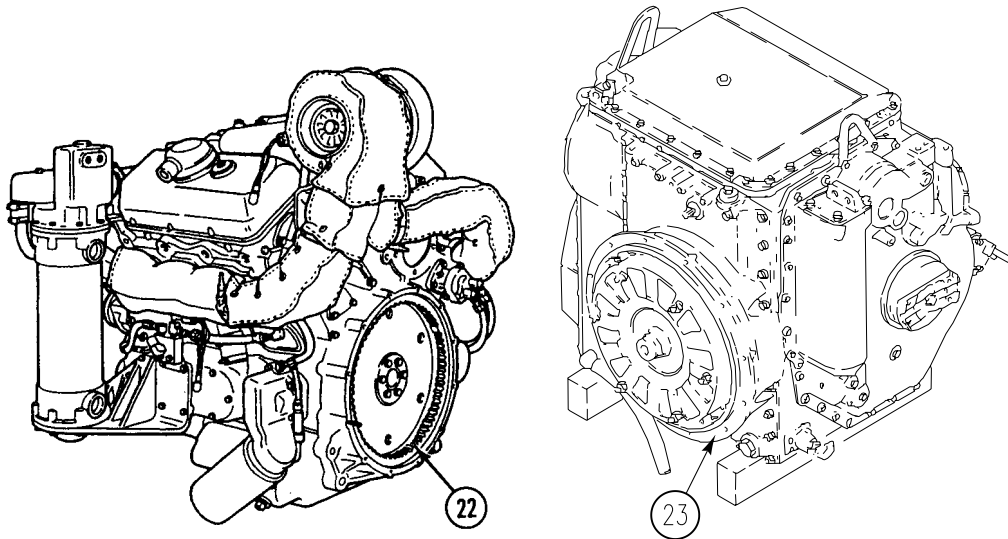

3. Install end cover (13) and secure with six screws (11) and washers (12) on transmission. TIGHTEN SIX SCREWS TO 156-180 IN-LB (18-20 N·m) TORQUE.

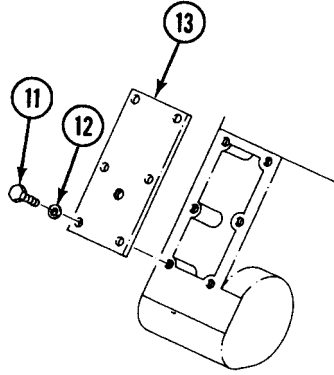

4. Install two variable speed clutch hose clamp brackets (12) on transmission. Secure with two screws (13) and washers (14).
5. Mount two variable speed hose clamps (11) on brackets (12) with two screws (8), washers (9), and new locknuts (10).

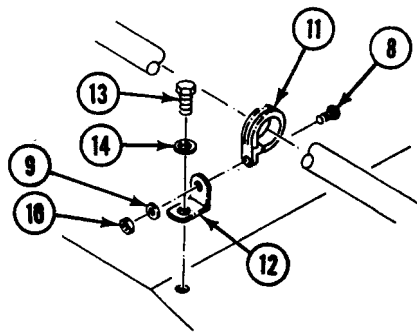

6. Position wiring harness (10) on transmission and connect rear connector (9) and front connector (8).

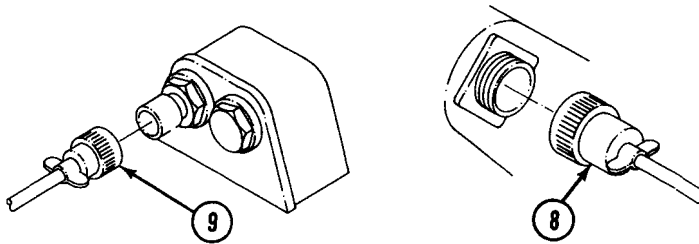

7. Install four wiring harness brackets (7) on transmission. Secure with four screws (5) and washers (6). TIGHTEN SCREWS TO 13-15 FT-LB (18-20 N·m) TORQUE.

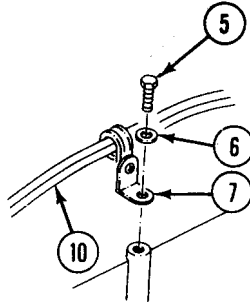

8. Install variable speed drive clutch supply hose elbow (10) on transmission filter case.

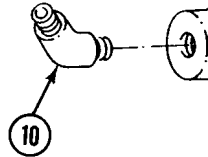

9. Install variable speed return hose elbow (7) on transmission end cover (8).

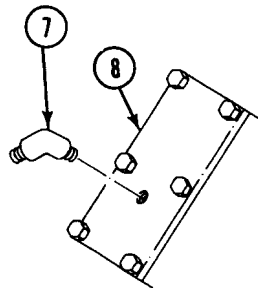

10. Secure adapter (12) and new gasket (13) to transmission with four screws (11). TIGHTEN FOUR SCREWS TO 27-32 LB-FT (36-44 N·m) TORQUE.

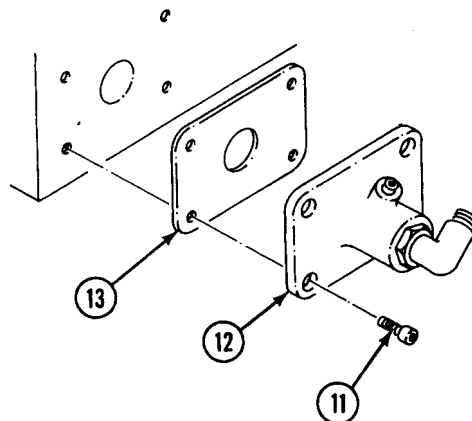

11. Install tow start control lever (3) and bracket (4) on transmission. Secure with two screws (1) and washers (2).

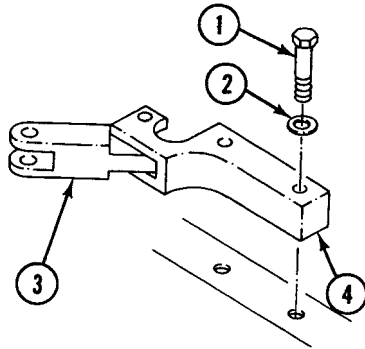

12. Install elbow (5) on transmission. Tighten jamnut (6).

13. Install oil outlet hose (4) on elbow (5). Do not tighten.

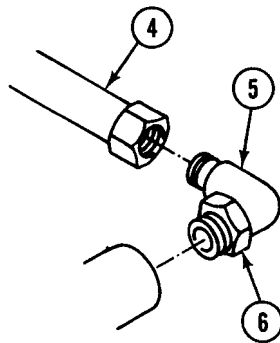

14. Secure engine wiring harness (9) to oil inlet hose with two new tiedown straps (8).

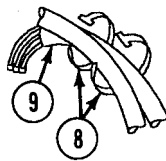

15. Remove transmission from blocks and place on power plant stand (2). Use sling (1) and suitable lifting device.

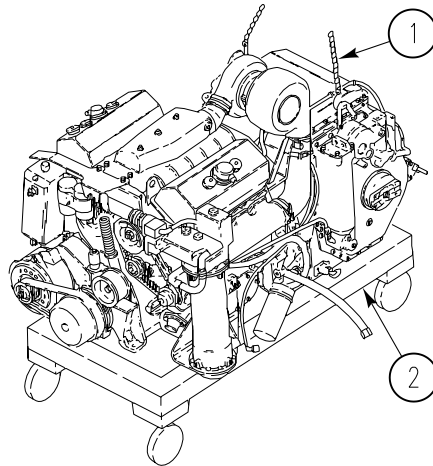

16. Place engine and transmission 1 to 2 inches apart and using screwdriver, rotate flywheel so that flywheel grooves line up with splined coupling grooves. Slide engine and transmission together and secure with 10 new self-locking bolts (3), 10 washers (4), screw (7), three washers (6), and two new locknuts (5). **TIGHTEN SCREW WITH LOCKNUT TO 38-41 FT-LB (52-56 N·m) TORQUE.** Tighten oil outlet hose. Use adjustable wrench.

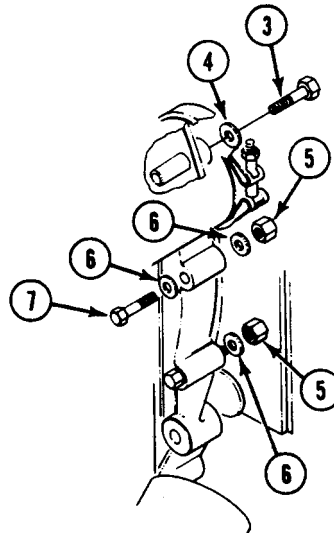

17. Connect variable speed drive clutch supply hose (9) to elbow (10) on transmission filter case.

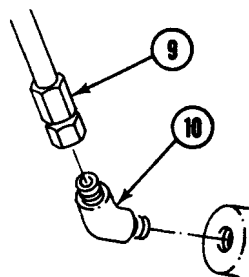

18. Connect variable speed drive clutch return hose (11) to elbow (12) on end cover at rear of transmission (13).

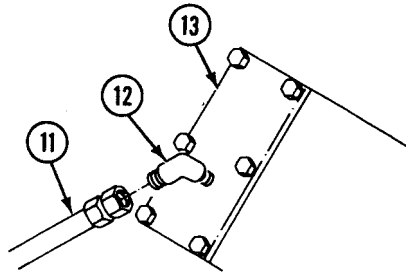

19. Install new preformed packing (10), transmission drain adapter (8), and nut (9) on transmission.
 20. Slide drain tube (7) and secure to transmission adapter (8). Tighten drain tube mount clamp (6).

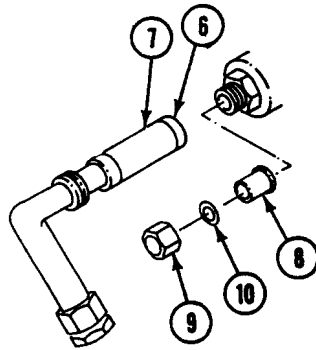

21. Remove pipe plug (16) from TV modulator pressure port. Apply sealing compound to all male threads before installation. Install pipe plug in elbow (15). Install elbow in transmission in the 1:00 to 2:00 o'clock position.
 22. Install TV modulator (14) on transmission. Secure with clamp (13) and new screw (12).

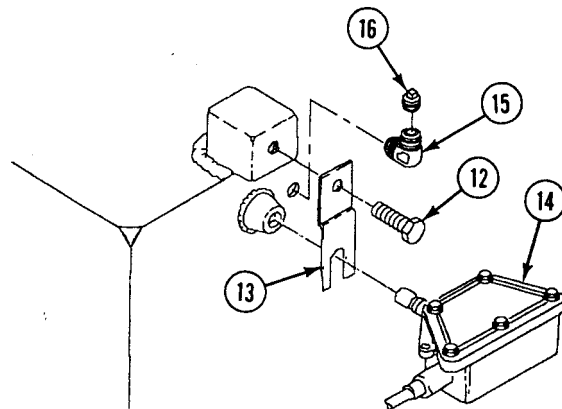

23. Install screw (1), washer (2), and steering lever (3) on transmission.

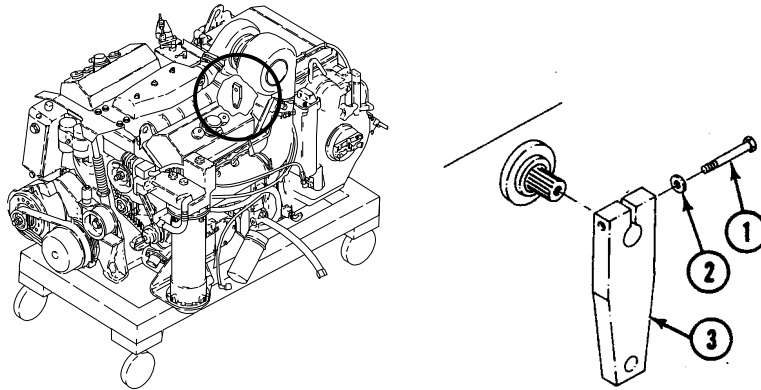

24. Install transmission oil inlet hose (10) on oil cooler outlet elbow (11).

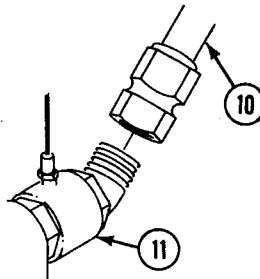

25. Mount inlet hose clamp bracket (5) on transmission with screw (6) and washer (7).

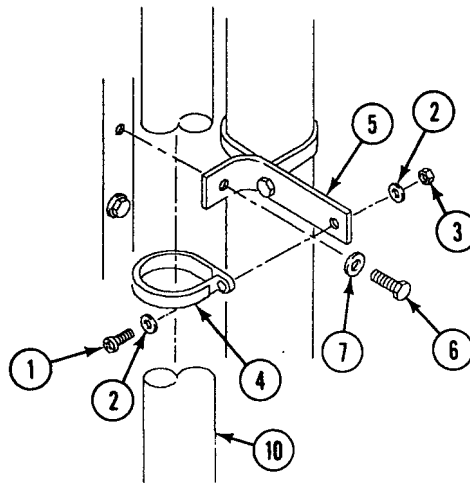

26. Connect circuit 34 lead (4) to engine oil low pressure switch (5).

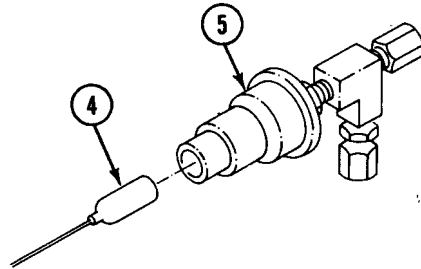

27. Connect transmission inlet hose (1) to elbow (2).

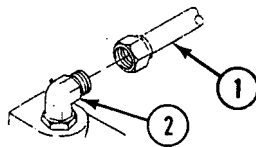

28. Secure inlet hose (10) to bracket (5) with clamp (4), screw (1), two washers (2), and new locknut (3). **TIGHTEN SCREW TO 27-32 LB-FT (36-44 N·m) TORQUE.**

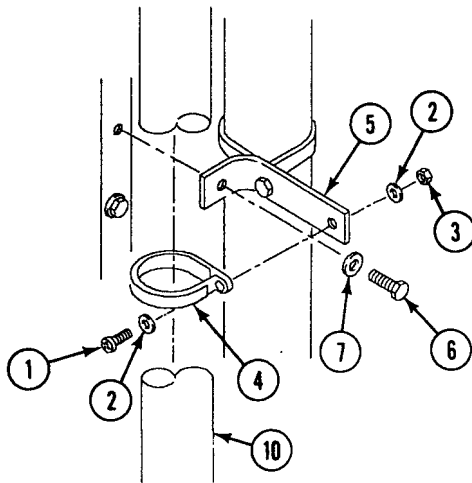

FOLLOW-THROUGH STEPS

1. Install ramp hydraulic pump (see your -20).
2. Install dipstick and filler tube (see your -20).
3. Install transmission oil sampling valve (see your -20).
4. Replace transmission oil (see your -20).

END OF TASK

CHAPTER 8

DIRECT SUPPORT MAINTENANCE INSTRUCTIONS
FOR WHEELS AND TRACKS

WORK PACKAGE INDEX

<u>Title</u>	<u>Sequence No.</u>
REPAIR TRACK IDLER ARM.....	0036 00
REPAIR TRACK TENSION ADJUSTER.....	0037 00

REPAIR TRACK IDLER ARM

0036 00

THIS WORK PACKAGE COVERS:

Removal (page 0036 00-1).
 Installation (page 0036 00-2).

INITIAL SETUP:

Maintenance Level

Direct Support

Personnel Required

Track Vehicle Repairer 63H10

Tools and Special Tools

General Mechanic's Tool Kit (WP 0120 00, Item 62)

References

See your -20

Materials/Parts

Packing (2)

Equipment Condition

Track idler arm assembly removed (see your -20)
 Hub assembly removed (see your -20)

REMOVAL

1. Remove retaining ring (1), cover (2), packing (3), and washer (4) from arm (5). Discard packing.
2. Remove retaining ring (6), arm (5), and packing (7) from spindle (8). Discard packing.
3. Remove two bearings (9) from arm (5).

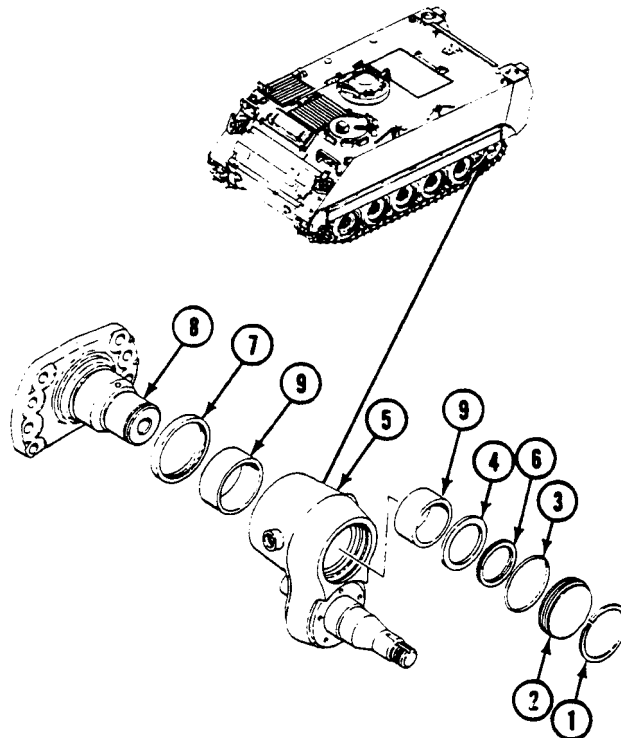

INSTALLATION

1. Install two bearings (9) in arm (5).
2. Install new packing (7) and arm (5) on spindle (8). Secure with retaining ring (6).
3. Install washer (4) and new packing (3) in arm (5).
4. Secure cover (2) in arm (5) with retaining ring (1).

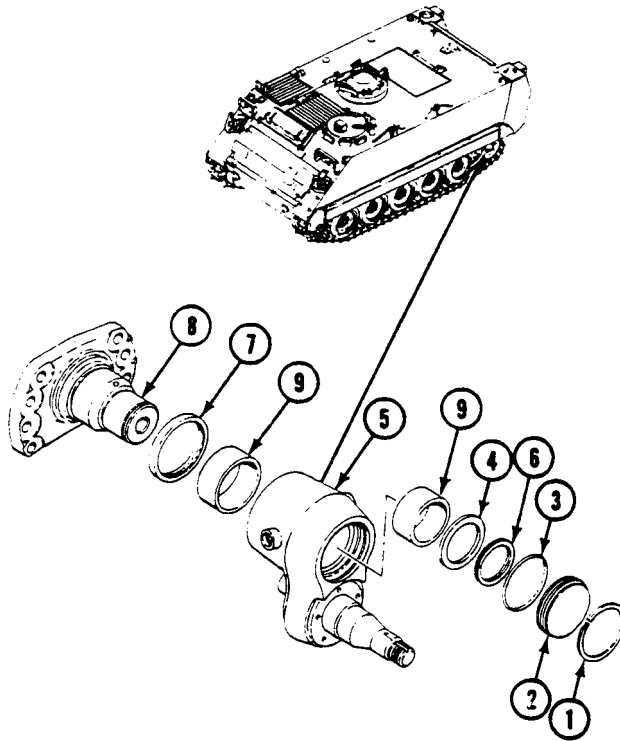
**FOLLOW-THROUGH STEPS**

1. Install track idler arm assembly (see your -20).
2. Install hub assembly (see your -20).

END OF TASK

REPAIR TRACK TENSION ADJUSTER

0037 00

THIS WORK PACKAGE COVERS:

- Removal (page 0037 00-1).
- Inspect and Repair (page 0037 00-4).
- Installation (page 0037 00-5).

INITIAL SETUP:

Maintenance Level

Direct Support

Personnel Required

Track Vehicle Repairer 63H10

Tools and Special Tools

- General Mechanic's Tool Kit (WP 0120 00, Item 62)
- Arbor Press (WP 0120 00, Item 43)

References

See your -20

Materials/Parts

- Engine oil (WP 0122 00, Item 13)
- Repair kit P/N 5703829
- Sleeve bearing (2)

Equipment Condition

Track tension adjuster removed (see your -20)

REMOVAL

1. Loosen bleeder valve (1). Push plunger (2) in as far as it will go.
2. Maintain inward pressure on plunger (2) and rotate counterclockwise until plunger rotates freely.

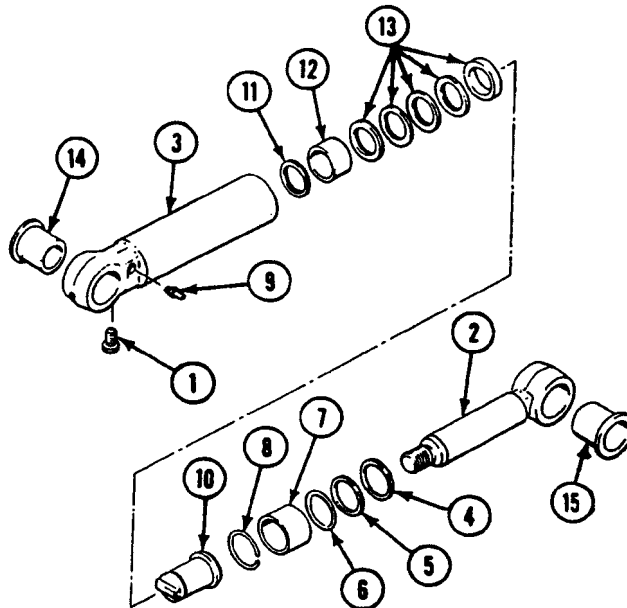

3. Pull plunger (2) from piston (3).
4. Remove retaining ring (4), wiper ring (5), and packing (6) from piston (3). Discard retaining ring, wiper ring, and packing.
5. Press bearing (7) about 1 inch (3 cm) in piston (3) to force retaining ring (8) from groove in piston.
6. Pull bearing (7) from piston (3). Discard bearing.

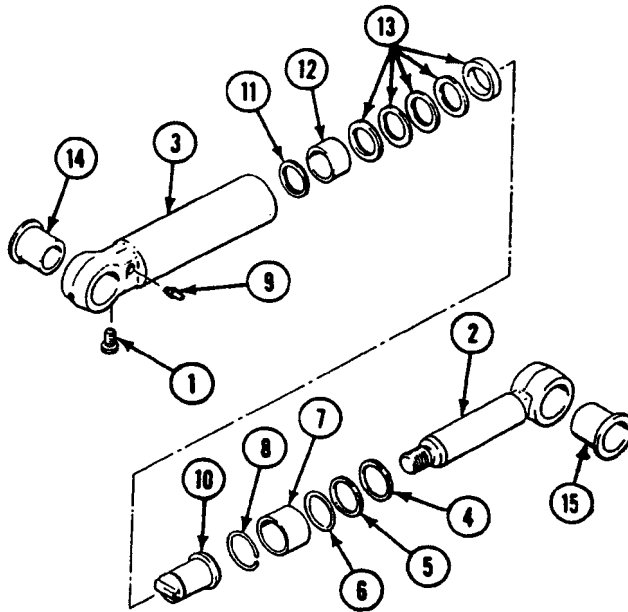

7. Turn retaining ring (8) 90 degrees in piston (3). Remove ring from piston. Discard ring.
8. Close bleeder valve (1). Force grease through lubrication fitting (9) until piston assembly (10) is forced from piston (3).
9. Use a clean cloth to remove excess grease from piston assembly (10) and piston (3).

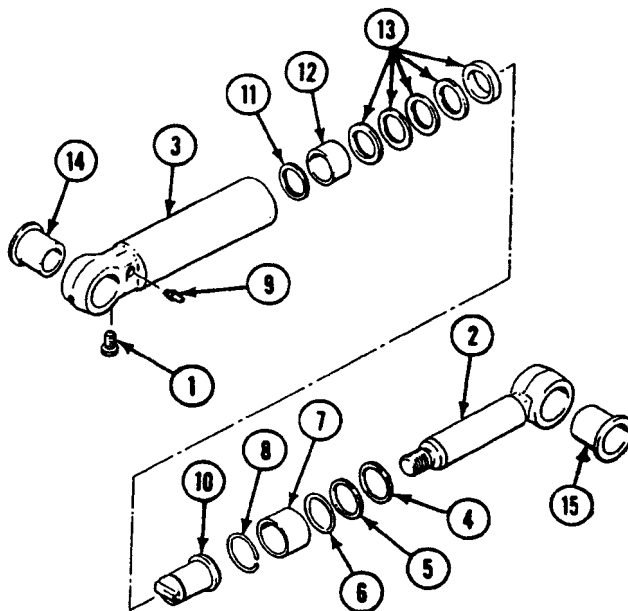

NOTE

Packing set may be a five or seven piece design.

10. Remove retaining ring (11), bearing (12), and five packings (13) from piston assembly (10). Discard packings, bearing, and retaining ring.
11. Remove bleeder valve (1) and lubrication fitting (9) from piston (3).
12. Press sleeve bearing (14) from piston (3). Discard sleeve bearing.
13. Press sleeve bearing (15) from plunger (2). Discard sleeve bearing.

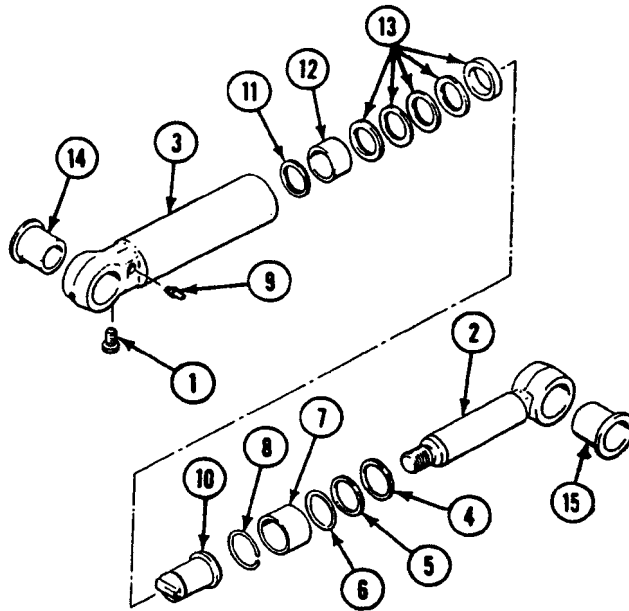

INSPECTION-ACCEPTANCE AND REJECTION CRITERIA

INSPECT AND REPAIR

1. Check threads of plunger (2) and piston (3). Chase damaged threads with a die. Replace parts as a matched set if the threads of either part are stripped or worn.
2. Check machined surfaces of piston (3) and plunger (2). Remove grooves and scratches. Replace parts that have deep grooves and scratches or are worn.

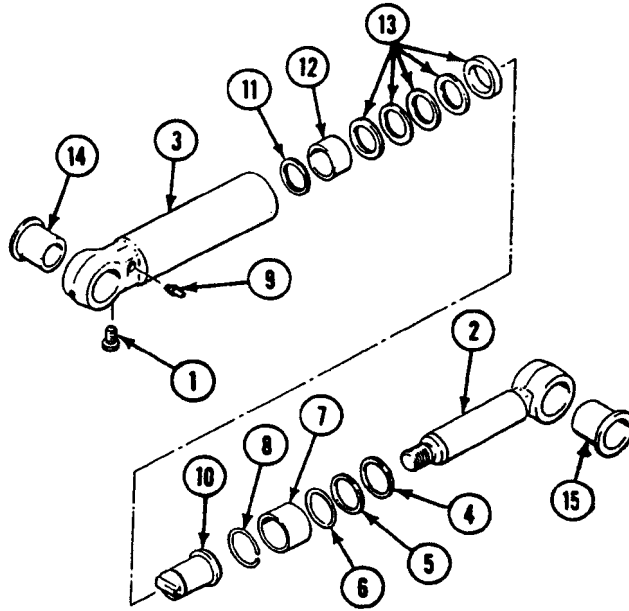

3. Check parts shown in table on page 0037 00-7 that have reference letters.
4. Check the parts dimensions with table on page 0037 00-7 to determine replacement.

INSTALLATION

1. Press new sleeve bearing (14) in piston (3) from side opposite lubrication fitting (9). Use arbor press.
2. Press new sleeve bearing (15) in plunger (2). Use arbor press.

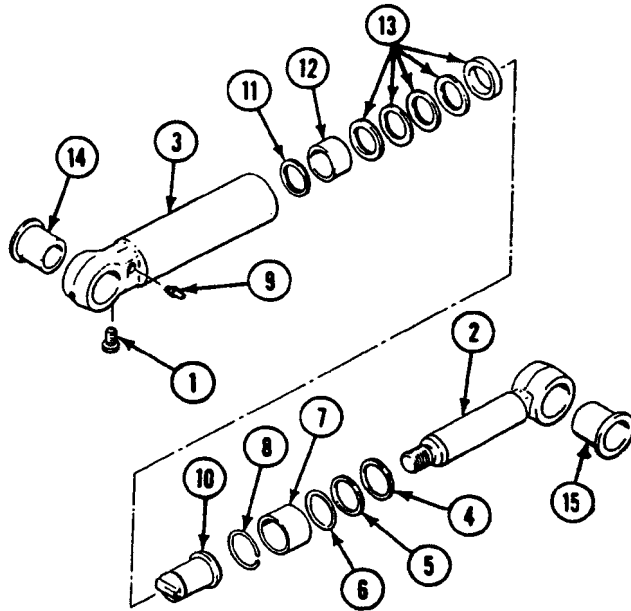

NOTE

Packings, bearings, and retaining rings are part of repair kit P/N 5703829.

3. Install five new packings (13), new bearing (12), and new retaining ring (11) on piston assembly (10).
4. Apply a light coat of engine oil to piston assembly (10) and to inside of piston (3).

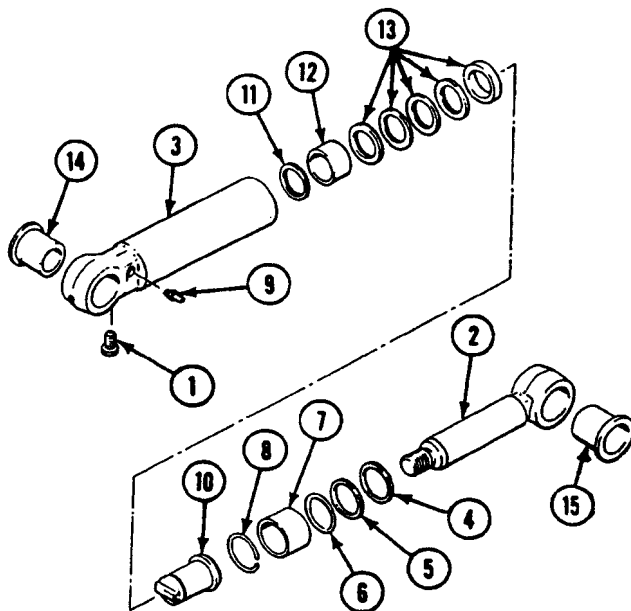

5. Install piston assembly (10) in piston (3).
6. Install new retaining ring (8) in piston (3). Make sure it seats in groove.
7. Install new bearing (7) in piston (3).
8. Install new packing (6), new wiper ring (5), and new retaining ring (4) in piston (3).
9. Install plunger (2) in piston (3). Maintain inward pressure on plunger and rotate clockwise until secure.
10. Install bleeder valve (1) and lubrication fitting (9) in piston (3).

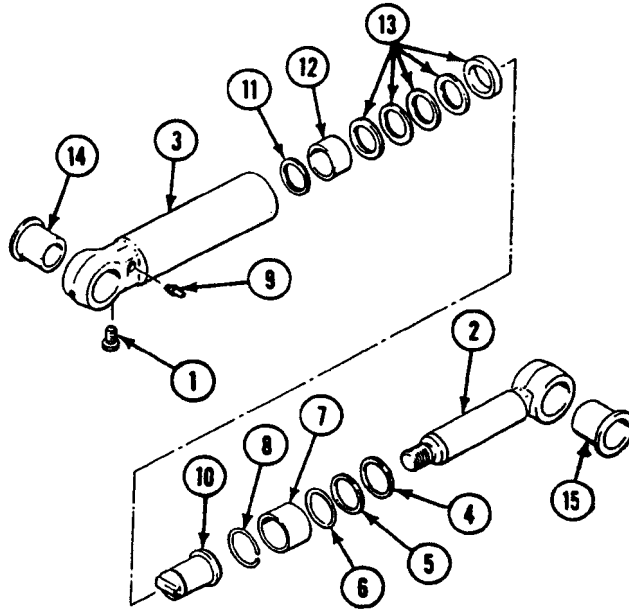

TRACK TENSION ADJUSTER

Reference Letter	Point of Measurement	Sizes and Fits of New Parts	Wear Limits
A	Outside diameter of plunger	1.7580 to 1.76000	1.7560
B	Outside diameter of piston	1.9940 to 1.9970	1.9930
C	Inside diameter of piston bearing	1.7620 to 1.7650	1.7670
D	Outside diameter of piston	1.4990 to 1.5010	1.4980
E	Outside diameter of sleeve	1.8780 to 1.8830	*
F	Inside diameter of sleeve	1.5200 to 1.5300	1.5450
G	Inside diameter of piston or plunger bearing bore	1.8740 to 1.8760	*
H	Inside diameter of piston bearing	1.5030 to 1.5060	1.5160
I	Outside diameter of piston bearing	1.9940 to 1.9970	1.9930
J	Inside diameter of piston bearing	1.9990 to 2.0010	2.0020

* Must be within new parts dimensions.

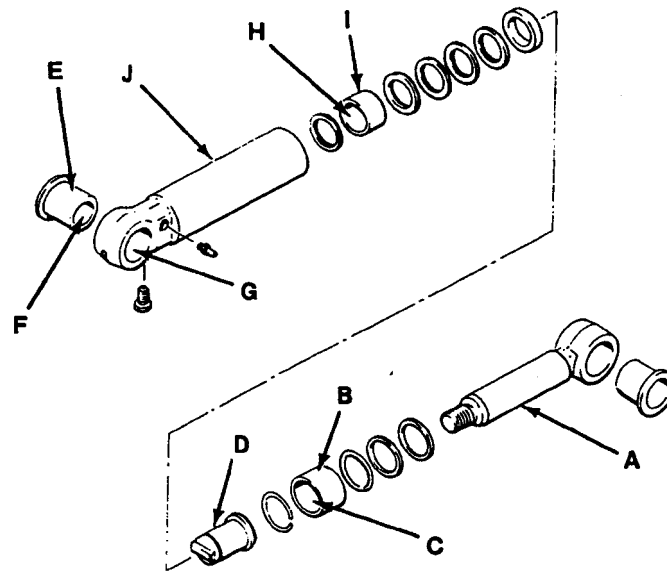

FOLLOW-THROUGH STEPS

1. Install track tension adjuster (see your -20).

END OF TASK

CHAPTER 9

DIRECT SUPPORT MAINTENANCE INSTRUCTIONS
FOR STEERING

WORK PACKAGE INDEX

<u>Title</u>	<u>Sequence No.</u>
Repair Steering Bracket And Shaft Housing Bearings.....	0038 00

REPAIR STEERING BRACKET AND SHAFT HOUSING BEARINGS

0038 00

THIS WORK PACKAGE COVERS:

Removal (page 0038 00-1).
 Installation (page 0038 00-2).

INITIAL SETUP:

Maintenance Level

Direct Support

Personnel Required

Track Vehicle Repairer 63H10

Tools and Special Tools

General Mechanic's Tool Kit (WP 0120 00, Item 62)
 Arbor Press (WP 0120 00, Item 43)

Equipment Condition

Steering brackets removed (see your -20)

Materials/Parts

Bearing
 Bearing
 Bearing (2)
 Bearing

REMOVAL

1. Press two bearings (1)(2) from bracket (3). Discard bearings.

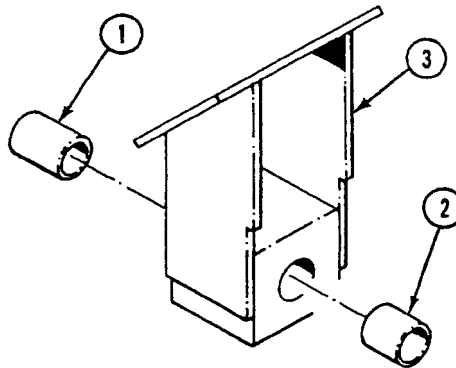

2. Press three bearings (4)(5)(6) from housing (7). Discard bearings.

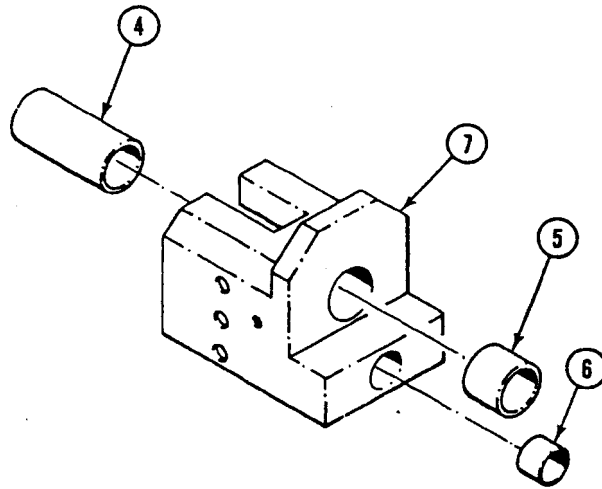

INSTALLATION

1. Place two new bearings (1)(2) on bracket (3) and press into place.

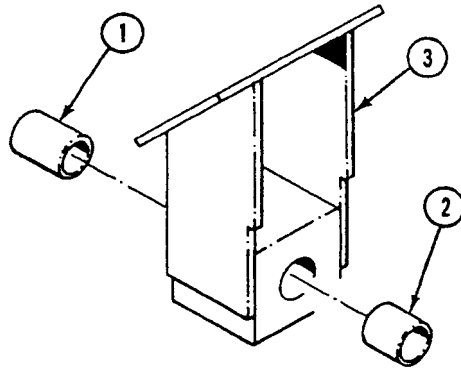

2. Place three new bearings (4)(5)(6) on housing (7) and press into place.

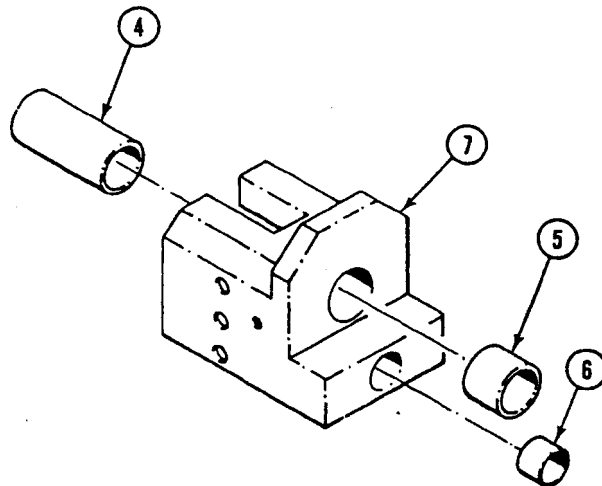

FOLLOW-THROUGH STEPS

1. Install steering brackets (see your -20).

END OF TASK

CHAPTER 10

DIRECT SUPPORT MAINTENANCE INSTRUCTIONS
FOR SHOCK ABSORBERS

WORK PACKAGE INDEX

<u>Title</u>	<u>Sequence No.</u>
REPAIR SHOCK ABSORBER.....	0039 00

REPAIR SHOCK ABSORBER

0039 00

THIS WORK PACKAGE COVERS:

Removal (page 0039 00-1).
 Installation (page 0039 00-1).

INITIAL SETUP:

Maintenance Level

Direct Support

Personnel Required

Track Vehicle Repairer 63H10

Tools and Special Tools

General Mechanic's Tool Kit (WP 0120 00, Item 62)
 Positioner (WP 0120 00, Item 42)
 Arbor Press (WP 0120 00, Item 43)
 Staker (WP 0120 00, Item 55)

References

See your -20

Materials/Parts

Bearing (2)

Equipment Condition

Shock absorber removed (see your -20)

REMOVAL

1. Remove two self-aligning bearings (1) from shock absorber (2). Use press (3), support (4), and positioner (5). Discard bearings.

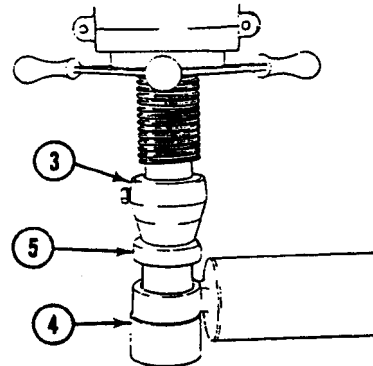
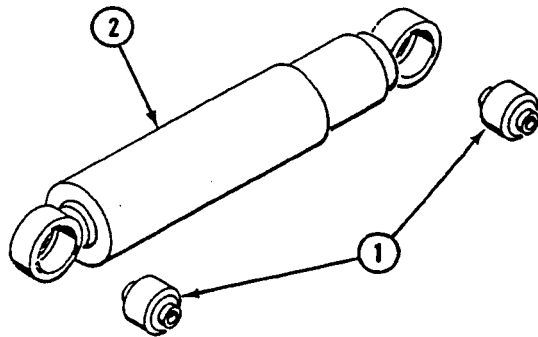

INSTALLATION

1. Install two new self-aligning bearings (1) in shock absorber (2). Use press (3) and two positioners (5).

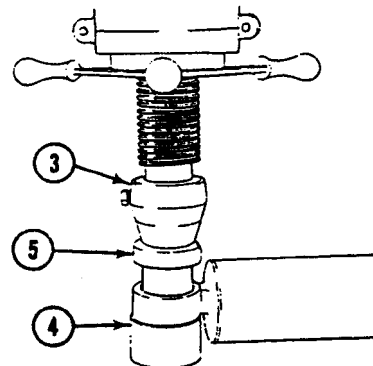
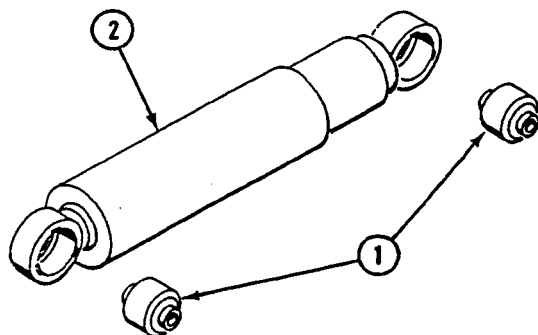

2. Stake two self-aligning bearings (1) into shock absorber (2). Use staker (6) and positioner (5).

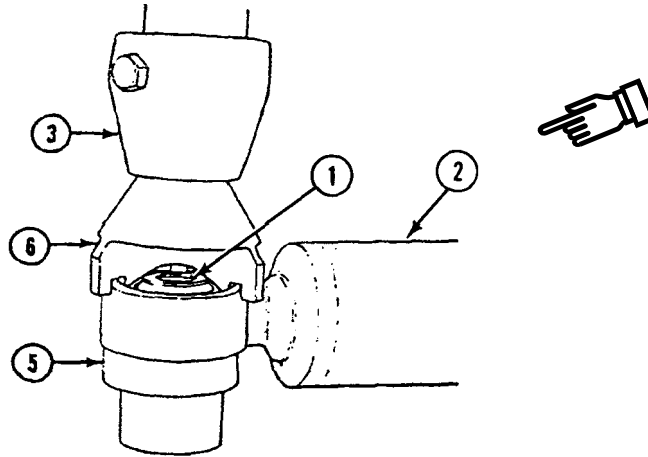

FOLLOW-THROUGH STEPS

1. Install shock absorber on carrier (see your -20).

END OF TASK

CHAPTER 11
DIRECT SUPPORT MAINTENANCE INSTRUCTIONS
FOR HULL

WORK PACKAGE INDEX

<u>Title</u>	<u>Sequence No.</u>
REPLACE SERRATED LOCK RING SCREW INSERTS.....	.0040 00
REPLACE SERRATED LOCK RING SCREW INSERT AND PACKING.....	.0041 00
REPLACE KEY LOCKED SCREW INSERTS.....	.0042 00
REPLACE PRESSNUT.....	.0043 00
REPLACE LEFT OR RIGHT SPLASH GUARD.....	.0044 00
DELETED □..... □.....	.0045 00
DELETED □..... □..... □..... □..... □..... □..... □..... □.....	.0046 00
REPAIR POWER PLANT DOOR HINGE.....	.0047 00
REPAIR CARGO HATCH HINGE (M113A3 AND M1059A3).....	.0048 00
REPAIR HOPPER HATCH HINGE (M58 ONLY).....	.0049 00
REPLACE COMMANDER'S CUPOLA (M113A3, M1059A3, M1064A3, AND M58 ONLY).....	.0050 00
REPAIR COMMANDER'S CUPOLA (M113A3, M1059A3, M1064A3, AND M58 ONLY).....	.0051 00
REPAIR COMMANDER'S CUPOLA BEARING (M113A3, M1059A3, M1064A3, AND M58 ONLY).....	.0052 00
REPAIR COMMANDER'S CUPOLA COVER HINGES (M113A3, M1059A3, M1064A3, AND M58 ONLY).....	.0053 00
REPAIR COMMANDER'S CUPOLA HINGES (M113A3, M1059A3, M1064A3, AND M58 ONLY).....	.0054 00
REPAIR COMMANDER'S HATCH COVER HINGES (M577A3 AND M1068A3 ONLY).....	.0055 00
REPAIR COMMANDER'S HATCH COVER HULL HINGES (M577A3 AND M1068A3 ONLY).....	.0056 00
REPLACE RAMP ACCESS DOOR AND HINGES (M113A3 ONLY).....	.0057 00
REPLACE RAMP ACCESS DOOR HINGE BEARINGS (M113A3 ONLY).....	.0058 00
REPAIR RAMP ACCESS DOOR (ALL EXCEPT M113A3).....	.0059 00
REPAIR DRIVER'S HATCH COVER HINGES.....	.0060 00
REPAIR DRIVER'S HATCH COVER HULL HINGES.....	.0061 00

REPLACE SERRATED LOCK RING SCREW INSERTS

0040 00

THIS WORK PACKAGE COVERS:

Removal (page 0040 00-1).
 Installation (page 0040 00-2).

INITIAL SETUP:

Maintenance Level

Direct Support

Materials/Parts

Screw insert

Personnel Required

Track Vehicle Repairer 63H10

Tools and Special Tools

- General Mechanic's Tool Kit (WP 0120 00, Item 62)
- Portable Electric Drill (WP 0120 00, Item 7 or WP 0120 00, Item 8)
- Screw Extractor Set (WP 0120 00, Item 14)
- Twist Drill (see Table 1 on page 0040 00-3)
- Insertor (see Table 1 on page 0040 00-3)
- Lock Ring Drive Tool (see Table 1 on page 0040 00-3)

References

See your -10

Equipment Condition

- Engine stopped (see your -10)
- Carrier blocked (see your -10)

REMOVAL

1. Drill out inside serrations of lock ring (1). Use drill same diameter as inside serrations. See Table 1 on page 0040 00-3.

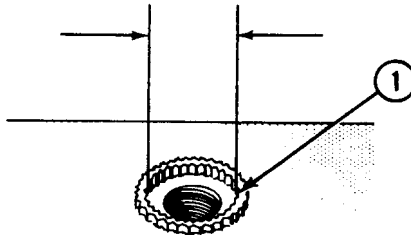

2. Drill to depth of counterbore (2).

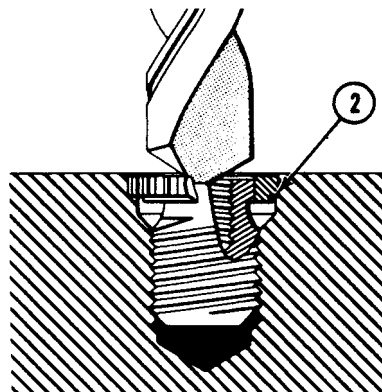

3. Drive in extractor tool (3) to screw out insert (4). As insert comes out, it will push out lock ring (5).
4. If lock ring (5) does not come out with insert (4), hit ring with a punch and hammer to collapse ring. Remove ring.

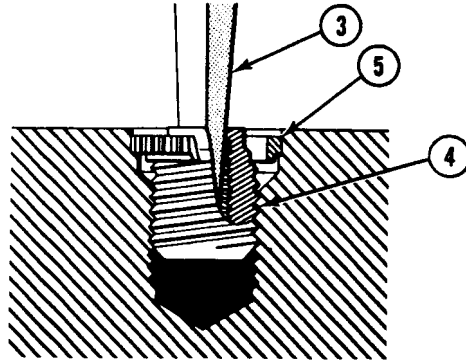

INSTALLATION

1. Install insert (1) in threaded hole. Use inserter (2). See Table 1 on page 0040 00-3.

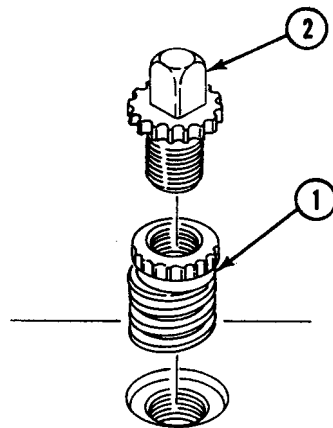

NOTE

Do not attempt to drive lock ring beyond the top surface of insert serrations.

2. Using lock ring drive tool. See Table 1 on page 0040 00-3, drive lock ring (3) into surface until drive tool (4) touches surface. Lock ring will be set at proper depth.

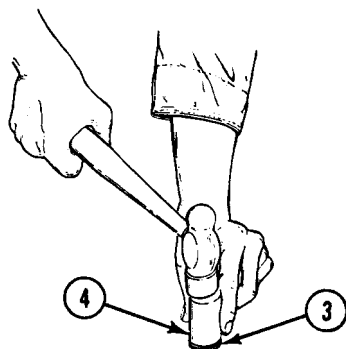

REPLACE SERRATED LOCK RING SCREW INSERTS — Continued

0040 00

Table 1. SERRATED LOCK RING SCREW INSERT DATA

INTERNAL THREAD SIZE	PART NUMBER/ NSN	REMOVAL DRILL DIAMETER/ WP 0120 00	INSERTER PART NO/ WP 0120 00	LOCK RING DRIVE TOOL PART NO/ WP 0120 00	APPLICATION
1/4-28 UNF	CR206SB8L 5340-01-066-2840	5/16 WP 0120 00	CR06W WP 0120 00	R206D WP 0120 00	Steering Installation.
3/8-16 UNC	CR108SB10 5340-00-930-1615	29/64 WP 0120 00	CR08W WP 0120 00	R108D WP 0120 00	Warning Lights Panel.
3/8-16 UNC	CR108SB10L 5340-00-930-1619	29/64 WP 0120 00	CR08W WP 0120 00	R108D WP 0120 00	Ramp Assembly. Trim Vane Mtg Provisions. Steering Instl Mtg Provisions. Hull Subassembly. Covered Extension Mtg Provisions (M577A3 & M1068A3).
1/2-20 UNF	CR210SB12L 5340-00-930-1618	11/16 WP 0120 00	CR10W WP 0120 00	R210D WP 0120 00	Power Train Mtg Provisions. Auxiliary Generator Mtg Provisions (M577A3 & M1068A3). Seats & Platform Instl (M577A3, M1064A3, & M1068A3 Only).
1/2-20 UNF	CR2410SB17 5340-01-074-5975	11/16 WP 0120 00	CR10W WP 0120 00	R210D WP 0120 00	Fuel Tank Cover.
1/2-20 UNF	CR1210SB17 5340-00-930-1617	11/16 WP 0120 00	CR10W WP 0120 00	R210D WP 0120 00	Armor Mtg Provisions (M113A3 Only). Litter Kit Mtg Provisions (M113A3 Only).
5/8-11 UNC	CR912SB16FL 5340-01-106-7977	57/64 WP 0120 00	CR12W WP 0120 00	R112D WP 0120 00	Power Plant Door. Ramp Assembly. Armor Mtg Provisions (M113A3 Only).
5/8-18 UNF	CR312SB16L 5340-00-921-6094	57/64 WP 0120 00	CR12W WP 0120 00	R212D WP 0120 00	Power Plant Door Mtg Provisions. Suspension Installation. Cupola (M113A3, M1059A3, & M1064A3 Only).
5/8-11 UNC	CRC2112SB16FL 5340-01-230-1627	57/64 WP 0120 00	CRB2112WIS WP 0120 00	CRB2112D WP 0120 00	Armor Mtg Provisions (M113A3 Only).
3/4-16 UNF	CR313SB18L 5340-00-999-5627	1-1/32 WP 0120 00	CR13W WP 0120 00	R213D WP 0120 00	Power Plant Door Mtg Provisions. Suspension Installation.

END OF TASK

REPLACE SERRATED LOCK RING SCREW INSERT AND PACKING

0041 00

THIS WORK PACKAGE COVERS:

Removal (page 0041 00-1).
 Installation (page 0041 00-2).

INITIAL SETUP:

Maintenance Level

Direct Support

Personnel Required

Track Vehicle Repairer 63H10

Tools and Special Tools

General Mechanic's Tool Kit (WP 0120 00, Item 62)
 Portable Electric Drill (WP 0120 00, Item 8)
 Drill Set (WP 0120 00, Item 10)
 Screw Extractor Set (WP 0120 00, Item 14)
 Bearing Inserter (WP 0120 00, Item 28)

References

See your -10

Materials/Parts

Sealing compound (WP 0122 00, Item 25)
 Preformed packing
 Screw insert

Equipment Condition

Engine stopped (see your -10)
 Access cover removed (see your -10)
 Carrier blocked (see your -10)

REMOVAL

1. Drill out inside serrations of lock ring (1). Use 11/16 inch drill.

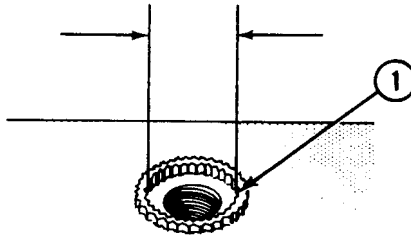

2. Drill to depth of counterbore (2). Maximum drill depth is 5/32.

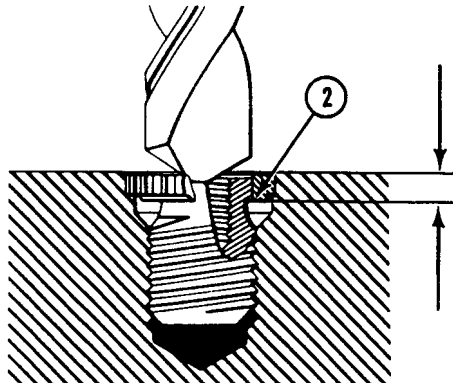

REPLACE SERRATED LOCK RING SCREW INSERT AND PACKING — Continued**0041 00**

3. Drive in extractor tool (3) to screw out insert (4). As insert comes out, it will push out lock ring (1).
4. If lock ring (1) does not come out with insert (4), hit ring with a punch and hammer to collapse ring. Remove ring. Discard insert.

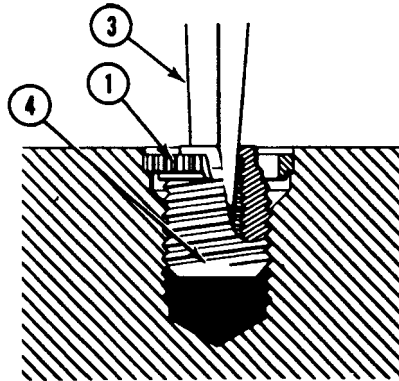
**INSTALLATION**

1. Lubricate new preformed packing (1) using fuel oil and install on new insert (2).

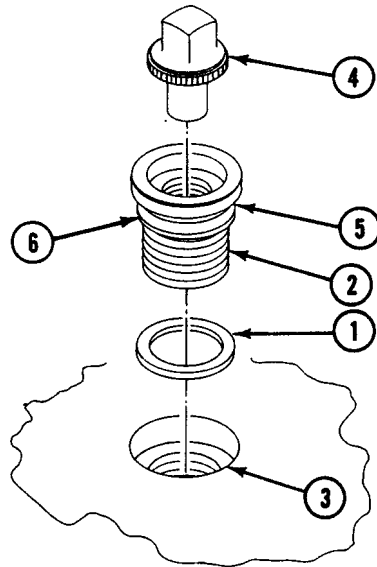

2. Coat male threads of insert (2) with sealing compound.
3. Wrench new insert (2) into threaded hole (3) by hand using wrench (4) until preformed packing (1) touches bottom of counterbore (5) and bottom of insert flange (6). Then wrench insert 1/4 to 3/8 of a turn further to compress preformed packing (1).

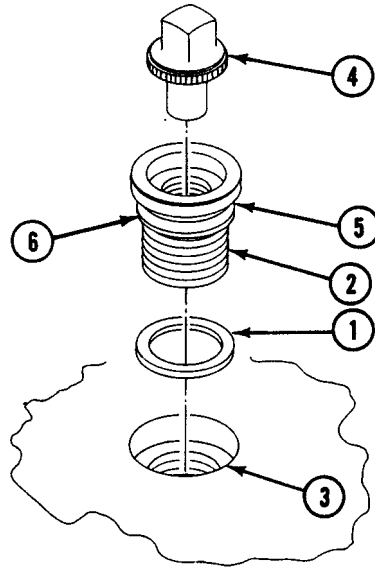

NOTE

Do not attempt to drive lock ring beyond the top surface of insert serrations.

4. Drive lock ring (7) into parent material (8) until drive tool touches the surface. This will set lock ring (7) to depth.

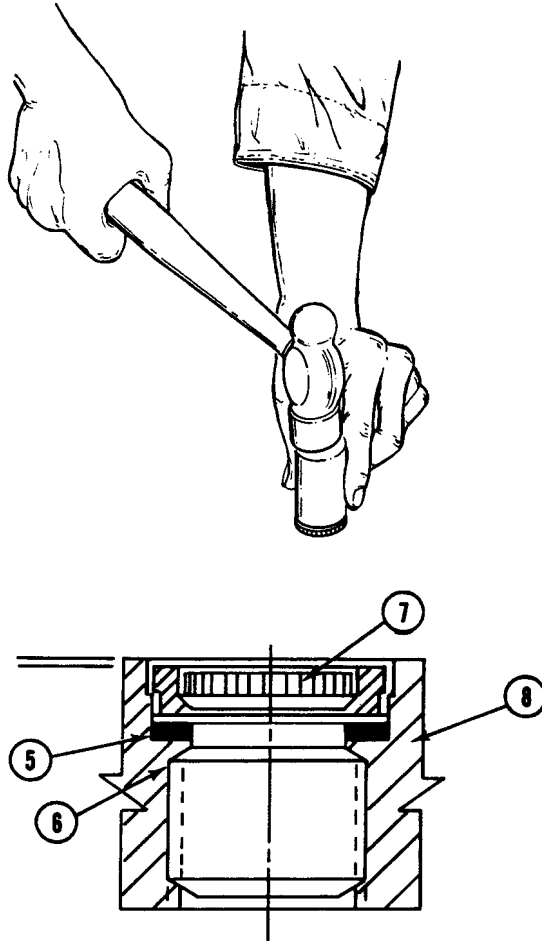

END OF TASK

REPLACE KEY LOCKED SCREW INSERTS

0042 00

THIS WORK PACKAGE COVERS:

Removal (page 0042 00-1).
 Installation (page 0042 00-2).

INITIAL SETUP:

Maintenance Level

Direct Support

Personnel Required

Track Vehicle Repairer 63H10

Tools and Special Tools

General Mechanic's Tool Kit (WP 0120 00, Item 62)
 Portable Electric Drill (WP 0120 00, Item 7)
 Drill Set (WP 0120 00, Item 9)
 Screw Extractor Set (WP 0120 00, Item 14)

References

See your -10

Equipment Condition

Carrier blocked (see your -10)
 Engine stopped (see your -10)

Materials/Parts

Screw insert

REMOVAL

1. Drill out insert (1) to depth of keys (2). See table on next page for correct drill size and depth.

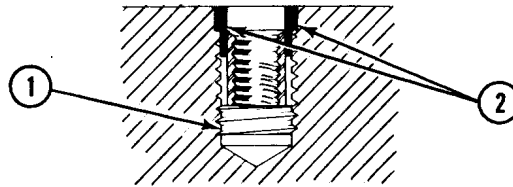

2. Bend keys (2) in to unlock insert (1). Break off bent portions of keys.

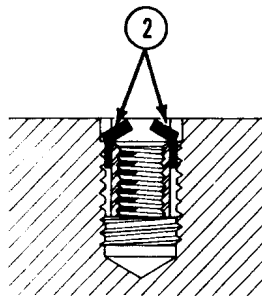

3. With all keys broken off, remove insert (1). Discard insert.

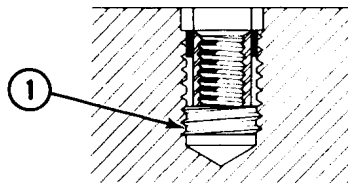

INSTALLATION

1. Install new insert (1) to dimension shown.

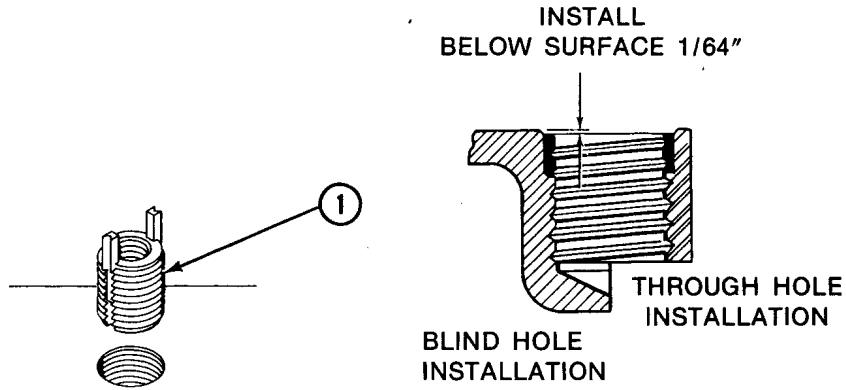

CAUTION

Take care not to break keys.

2. Drive keys (1) flush with surrounding surface.

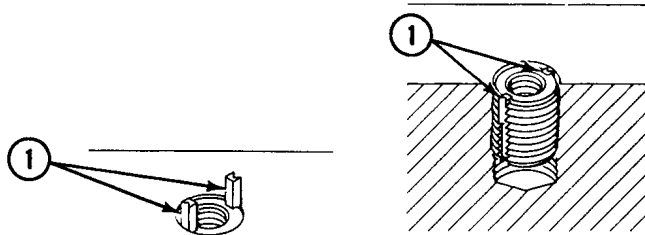

Table 1. KEY-LOCKED SCREW INSERT DATA

INTERNAL THREAD SIZE	PART NUMBER/ NSN	REMOVAL DRILL DIAMETER	REMOVAL DRILL DEPTH	APPLICATION
3/8-16UNJC-3B	MS51813-104 5340-01-066-2840	.469 (15/32)	.187 (3/16)	Air Cleaner Mtg Provisions.
3/8-16UNC-3B	7771298-6 (19207) 5340-00-931-7253	.281 (9/32)	.125 (1/8)	Cover Extension Mtg Provisions (M577A3 & M1068A3 Only).
1/2-20UNF-3B	7771298-1 (19207) 5340-00-115-9420	.656 (21/32)	.188 (3/16)	Seats & Platform Installation (M577A3, M1064A3, M1068A3). Covered Extension Mtg Provisions (M577A3 & M1068A3 Only). Hull Bolted Subassy.
5/8-18UNF-3B	7771298-2 (19207) 5340-00-016-0025	.781 (25/32)	.188 (3/16)	Suspension Installation. Hull Bolted Subassy
3/4-16UNF-3B	7771298-3 (19207) 5340-00-111-7360	.969 (31/32)	.313 (5/16)	Suspension Installation. Hull Bolted Subassy.

END OF TASK

REPLACE PRESSNUT

0043 00

THIS WORK PACKAGE COVERS:

Removal (page 0043 00-1).
 Installation (page 0043 00-2).

INITIAL SETUP:

Maintenance Level

Direct Support

Personnel Required

Track Vehicle Repairer 63H10
 Metal Worker 44B10

Tools and Special Tools

General Mechanic's Tool Kit (WP 0120 00, Item 62)
 Trailer Mounted Welding Shop (WP 0120 00, Item 69)
 Portable Electric Drill (WP 0120 00, Item 7)
 Twist Drill Set (WP 0120 00, Item 9)

References

See your -10
 TM 9-237

Materials/Parts

Pressnut

Equipment Condition

Engine stopped (see your -10)
 Carrier blocked (see your -10)

REMOVAL

NOTE

Pressnuts which are loose or have unrepairable damaged threads shall be replaced using the procedure below.

1. Remove pressnut (1) by pressing out.

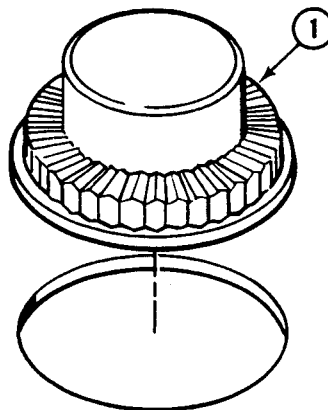

2. Enlarge the hole in the parent material (2) to accommodate method A, B, or C repair options.

NOTE

If replacing pressnuts in the driver's floor plate, install pressnut into formed material, then weld formed material to floor plate in accordance with method C. Use floor plate cover for template.

3. If required: form a piece of material (3) to fill or cover the hole in parent material (same thickness and material as parent material).
4. If required: weld formed piece of material (3) in place in accordance with TM 9-237.

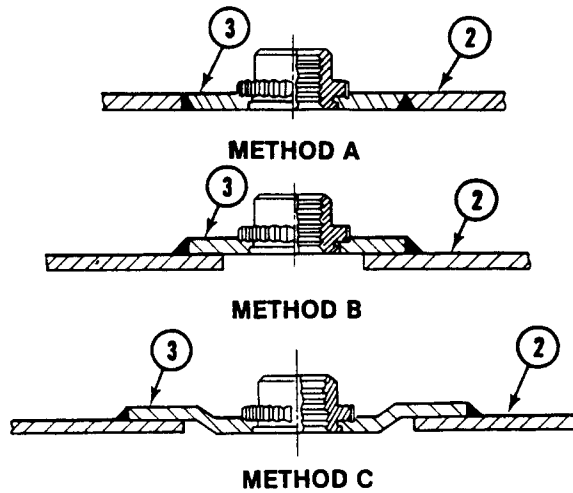

INSTALLATION

1. If required: drill or punch hole (1) of proper size in new repaired material. See Table 1, page 0043 00-3.
2. Do not chamfer, break or deburr edges of hole on entering side (2). Installation should always be made on the exit side on the punched holes.
3. Drive new pressnut with appropriate drive tool to properly seat pressnut in repaired material.

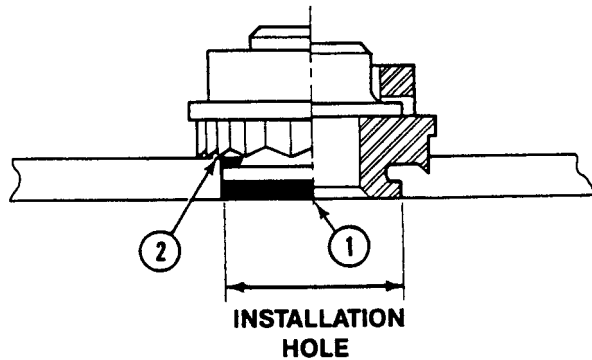

Table 1. PRESSNUT TECHNICAL DATA

PART NUMBER/NSN	HOLE DIAMETER	MINIMUM MATERIAL THICKNESS	APPLICATION
7341627 5310-00-982-3356	3/8	1/16	FUEL CONTROL INSTALLATION
7341628 5310-00-758-1900	3/8	1/16	ENGINE COOLANT HEATER INSTALLATION HEATER COMPARTMENT
7341632 5310-00-073-0131	1/2	1/8	METAL GRILL FAN MOUNTING. ENGINE COOLANT MOUNTING PROVISIONS. DRIVER'S FLOOR PLATE

END OF TASK

REPLACE LEFT OR RIGHT SPLASH GUARD

0044 00

THIS WORK PACKAGE COVERS:

Removal (page 0044 00-1).
 Installation (page 0044 00-2).

INITIAL SETUP:

Maintenance Level

Direct Support

Personnel Required

Metal Worker 44B10

Tools and Special Tools

General Mechanic's Tool Kit (WP 0120 00, Item 62)
 Metal Worker's Tool Kit (WP 0120 00, Item 63)
 Trailer Mounted Welding Shop (WP 0120 00, Item 69)
 Sander Spindle Adapter (WP 0120 00, Item 1)
 Welder's Gloves (WP 0120 00, Item 18)
 Industrial Goggles (WP 0120 00, Item 19)
 Welder's Helmet (WP 0120 00, Item 21)
 Electric Disc Sander (WP 0120 00, Item 47)
 Arc Welding Machine (WP 0120 00, Item 68)

References

See your -10
 See your -20
 TM 9-237
 TM 43-0139

Equipment Condition

Engine stopped (see your -10)
 Carrier blocked (see your -10)
 Track on damaged side removed (see your -20)
 Drive sprocket carrier on damaged side removed
 (see your -20)

Materials/Parts

Enamel (WP 0122 00, Item 12)
 Splash guard

REMOVAL

NOTE

Left front splash guard is shown. Right side is opposite and is welded accordingly.

1. Remove damaged splash guard (1) and grind weld area smooth.

- Clean weld area per TM 9-237.

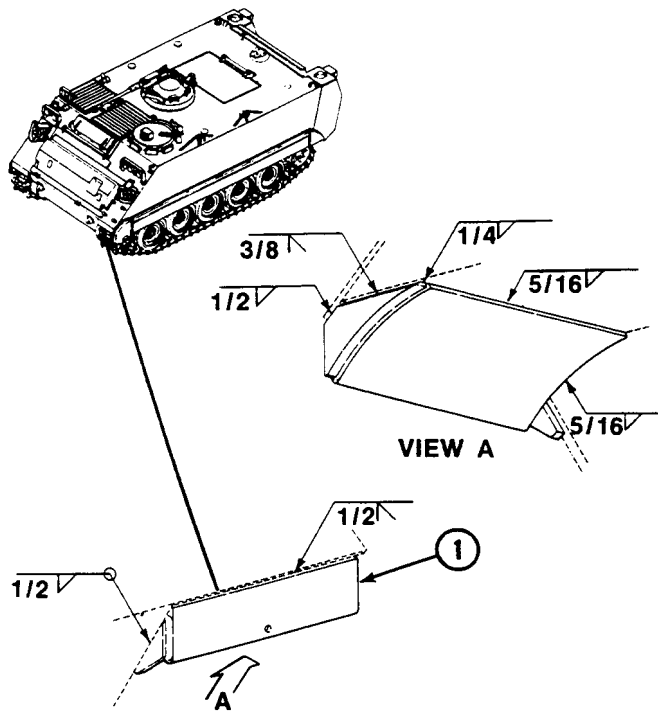

INSTALLATION

- Locate new splash guard (1) and weld as shown and per TM 9-237.
- Clean all bare metal and paint per TM 43-0139.

FOLLOW-THROUGH STEPS

- Install drive sprocket carrier (see your -20).
- Install track (see your -20).
- Deleted.

END OF TASK

REPAIR POWER PLANT DOOR HINGE

0047 00

THIS WORK PACKAGE COVERS:

- Removal (page 0047 00-1).
 - Installation (page 0047 00-3).
-

INITIAL SETUP:

Maintenance Level

Direct Support

Materials/Parts

- Enamel (WP 0122 00, Item 12)
- Welding electrode (WP 0122 00, Item 35)

Tools and Special Tools

- Metal Worker's Tool Kit (WP 0120 00, Item 63)
- Trailer Mounted Welding Shop (WP 0120 00, Item 69)
- Sander Spindle Adapter (WP 0120 00, Item 1)
- Welder's Gloves (WP 0120 00, Item 18)
- Industrial Goggles (WP 0120 00, Item 19)
- Welder's Helmet (WP 0120 00, Item 21)
- Electric Disc Sander (WP 0120 00, Item 46)
- Arc Welding Machine (WP 0120 00, Item 68)

Personnel Required

Metal Worker 44B10

References

- See your -20
- TM 43-0139
- TM 9-237

Equipment Condition

- Power plant door removed (see your -20)
 - Power plant door seal removed from hinge (see your -20)
-

REMOVAL

1. Remove remaining portion of damaged hinge (1) or (2) from door (3).

WARNING

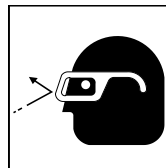

Metal chips and grinding dust can cause injury. Wear goggles and gloves.

2. Use a machinist hammer and a cold chisel to chip off remaining part of bad hinge (1) or (2) from door (3).

3. Use a disc sander to sand chipped area smooth and remove any hard coating from weld area.

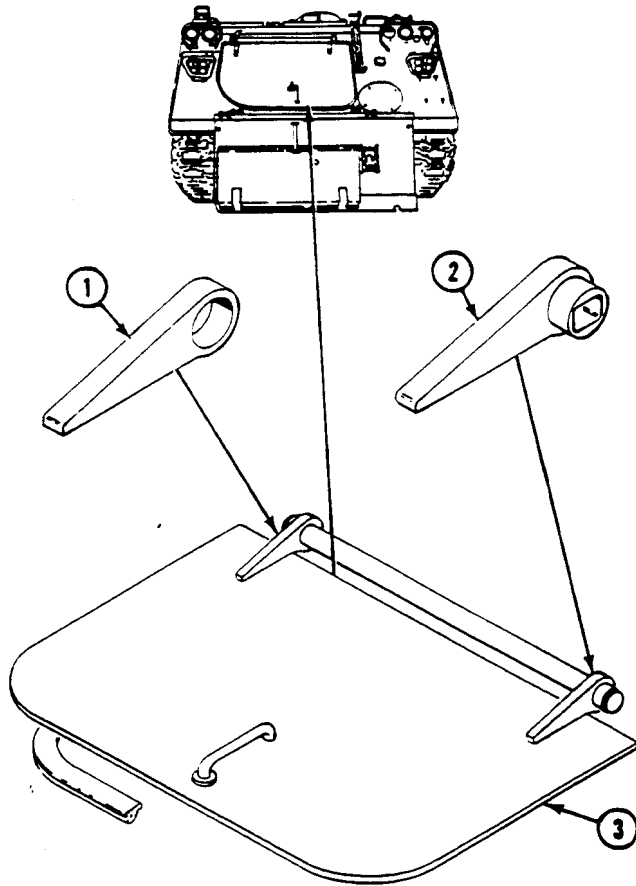

4. Use spring shield (1) from disassembled carrier to align new hinge (2) or (3) onto door (4).

INSTALLATION

1. Tack weld hinge (2) or (3) to door (4). Recheck measurement shown before completing required weld.

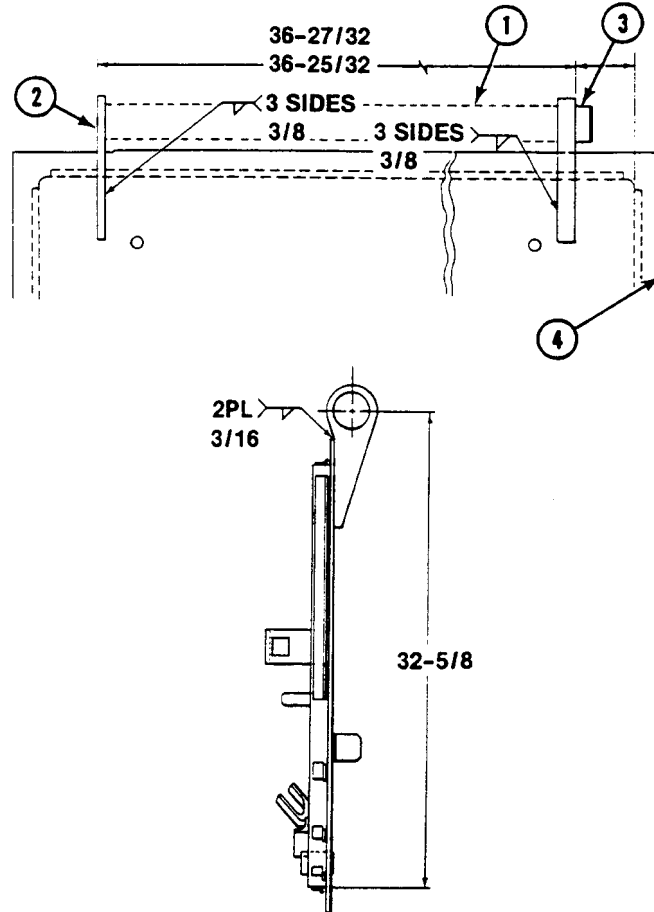

2. Complete weld on new hinge. See TM 9-237. Use electrode 5356.
3. Clean the weld area and apply touch-up paint to repaired area. See TM 43-0139.

FOLLOW-THROUGH STEPS

1. Install door on carrier (see your -20).
2. Install seal on hinge edge of door (see your -20).

END OF TASK

REPAIR CARGO HATCH HINGE (M113A3 AND M1059A3)

0048 00

THIS WORK PACKAGE COVERS:

Removal (page 0048 00-1).
 Installation (page 0048 00-3).

INITIAL SETUP:

Maintenance Level

Direct Support

Tools and Special Tools

Metal Worker's Tool Kit (WP 0120 00, Item 63)
 Trailer Mounted Welding Shop (WP 0120 00, Item 69)
 Sander Spindle Adapter (WP 0120 00, Item 1)
 Welder's Gloves (WP 0120 00, Item 18)
 Industrial Goggles (WP 0120 00, Item 19)
 Welder's Helmet (WP 0120 00, Item 21)
 Electric Disc Sander (WP 0120 00, Item 46)
 Arc Welding Machine (WP 0120 00, Item 68)

Materials/Parts

Enamel (WP 0122 00, Item 12)
 Welding electrode (WP 0122 00, Item 35)

Personnel Required

Metal Worker 44B10

References

See your -20
 TM 43-0139
 TM 9-237
 Welding Code 12472301

Equipment Condition

Cargo hatch removed from carrier (see your -20)

REMOVAL

WARNING

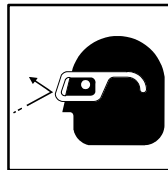

Metal chips and grinding dust can cause injury. Wear goggles and gloves.

1. Remove and discard broken hinge (1) or (2) from hatch (3).
2. Use a machinist hammer and a cold chisel to chip off remaining part of bad hinge (1) or (2) from cargo hatch (3).
3. Use a disc sander to sand chipped area smooth and remove any hard coating from weld area.

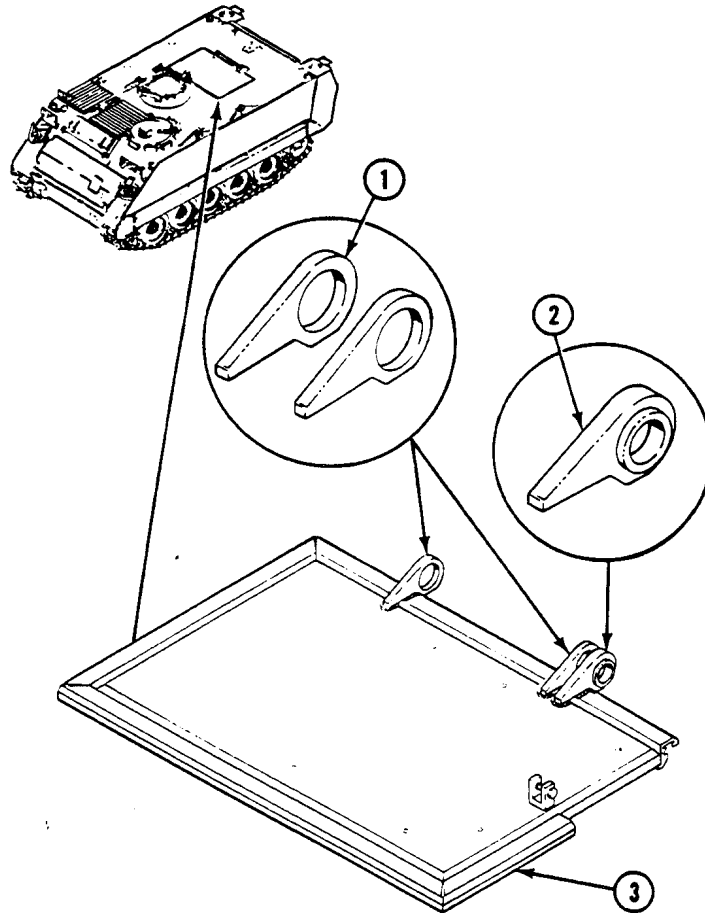

4. Remove rubber seal (1) from hinge edge of hatch (2).

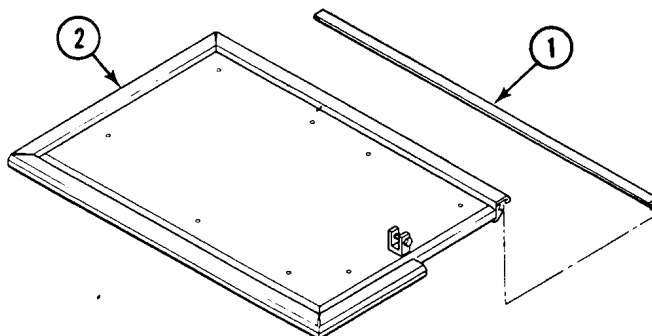

INSTALLATION

NOTE

All weld joints should be metal to metal fit. In no case should weld gap exceed 3/32 inch or one half the thickness of thinner member, whichever is less.

1. Clamp or tack weld new hinge (3) or (4) on hatch (2).
2. Make sure hinges are aligned and spaced as shown.
3. Weld hinge (3) or (4) to hatch. [See TM 9-237 and Weld Code 12472301. Use electrode type E5356.]

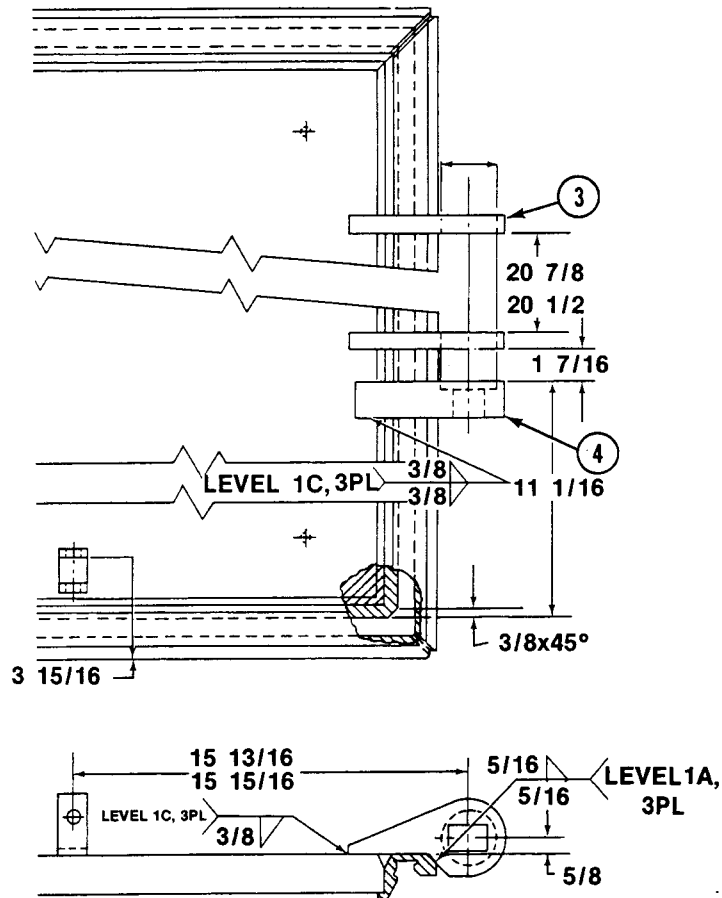

4. Clean weld area and apply touch-up paint to repaired area. See TM 43-0139. Install rubber seal (1) along edge of hatch (2).

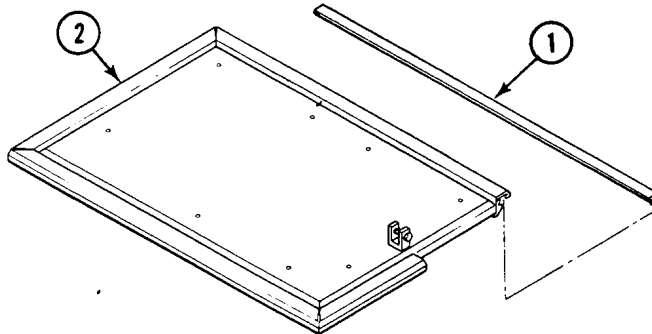
**FOLLOW-THROUGH STEPS**

1. Install cargo hatch on carrier (see your -20).

END OF TASK

REPAIR HOPPER HATCH HINGE (M58 ONLY)

0049 00

THIS WORK PACKAGE COVERS:

- Removal (page 0049 00-1).
 - Installation (page 0049 00-3).
-

INITIAL SETUP:

Maintenance Level

Direct Support

Materials/Parts

Welding electrode (WP 0122 00, Item 35)

Tools and Special Tools

- Metal Worker's Tool Kit (WP 0120 00, Item 63)
- Trailer Mounted Welding Shop (WP 0120 00, Item 69)
- Sander Spindle Adapter (WP 0120 00, Item 1)
- Welder's Gloves (WP 0120 00, Item 18)
- Industrial Goggles (WP 0120 00, Item 19)
- Welder's Helmet (WP 0120 00, Item 21)
- Electric Disc Sander (WP 0120 00, Item 46)
- Arc Welding Machine (WP 0120 00, Item 68)

Personnel Required

Metal Worker 44B10

References

- See your -20
- TM 43-0139
- TM 9-237

Equipment Condition

Hopper hatch removed from carrier (see your -20)

REMOVAL

WARNING

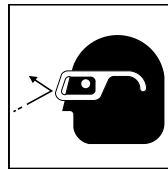

Metal chips and grinding dust can cause injury. Wear goggles and gloves.

1. Remove and discard broken hinge (1) or (2) from hatch (3).
2. Use a machinist hammer and a cold chisel to chip off remaining part of bad hinge (1) or (2) from hatch (3).

3. Use a disc sander to sand chipped area smooth and remove any hard coating from weld area.

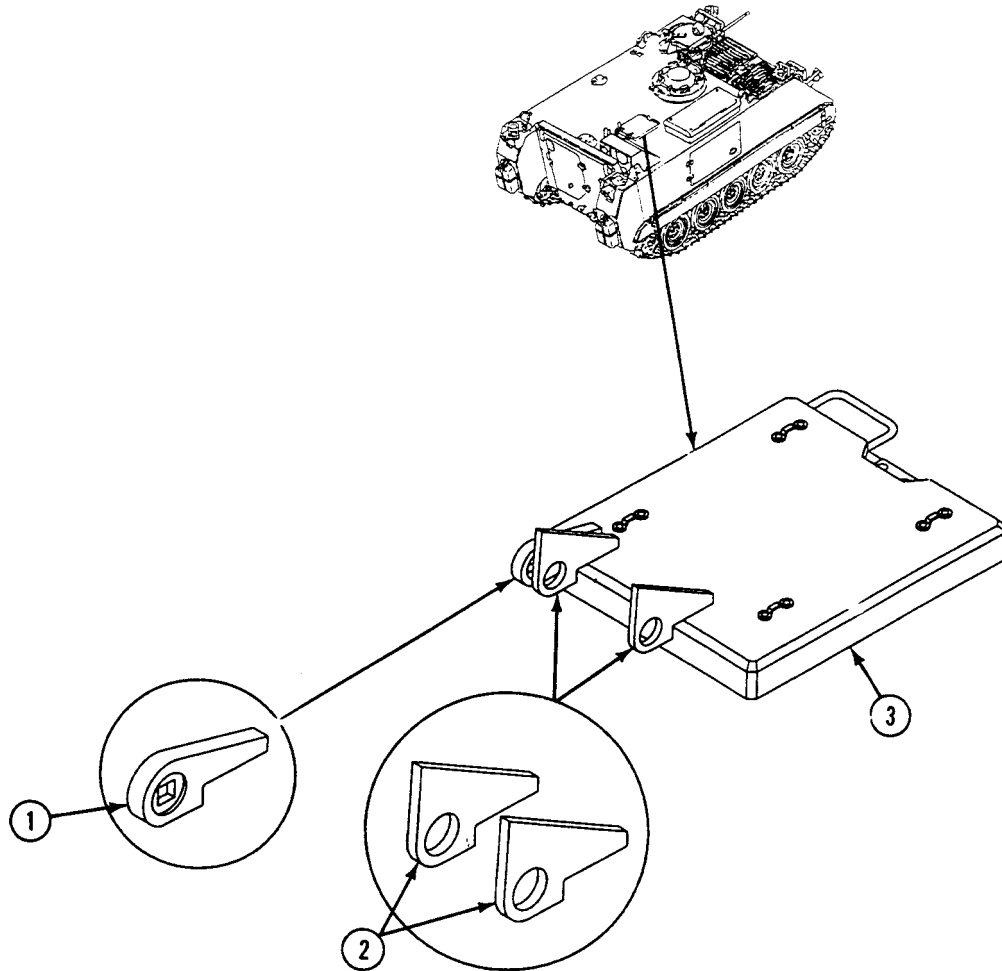

4. Bend four retaining strips (1) up, and remove rubber seal (2) from hatch (3).

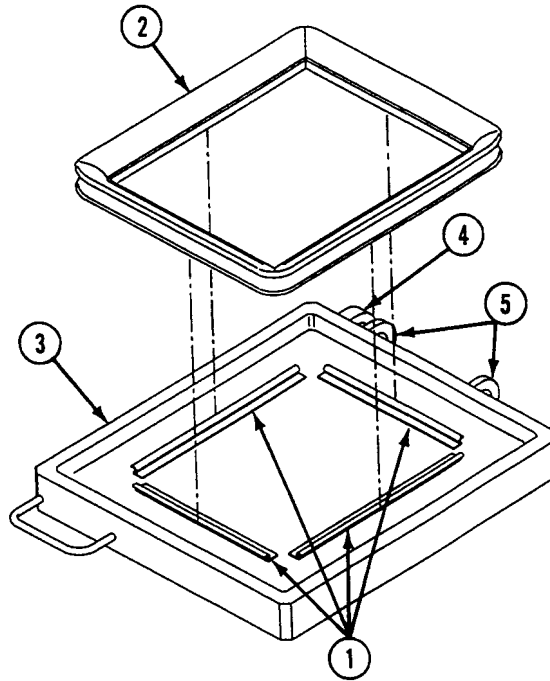

INSTALLATION

NOTE

All weld joints should be metal to metal fit. In no case should weld gap exceed 3/32 inch or one half the thickness of thinner member, whichever is less.

1. Clamp or tack weld new hinge (4) or (5) on hatch (3). Make sure hinges are aligned and spaced as shown.

2. Weld hinge (4) or (5) to hatch. See TM 9-237. Use electrode type 5356.

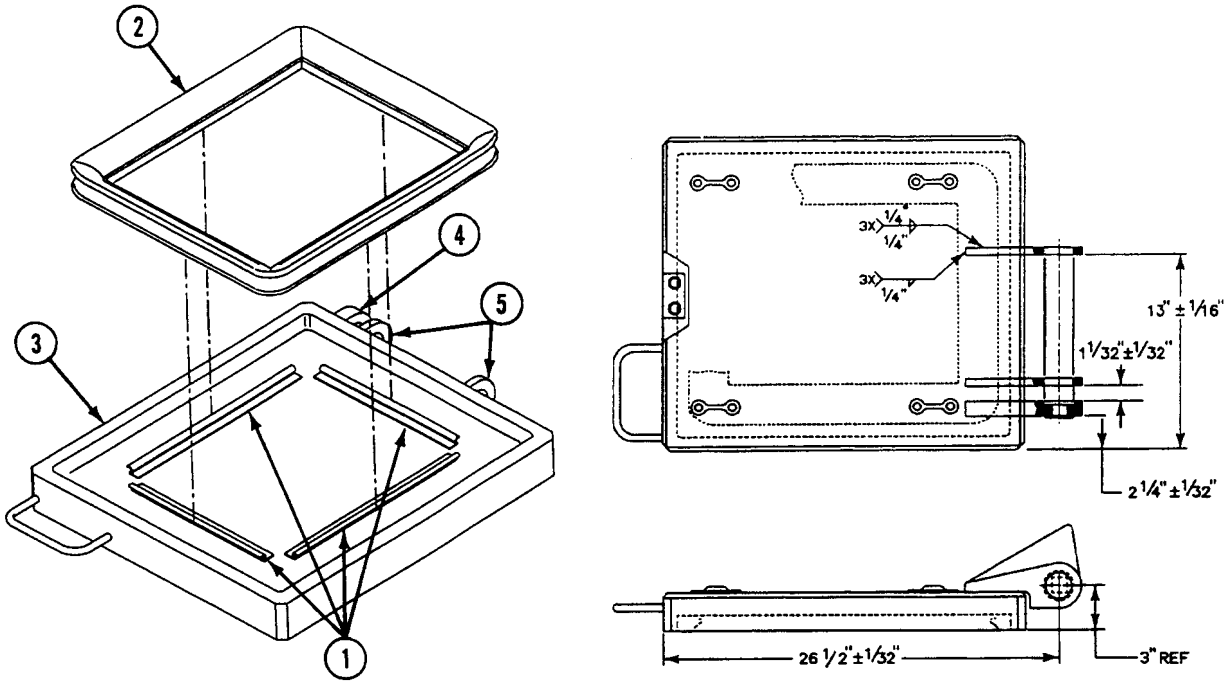

NOTE

Do not prime or top coat inside bore of hinges.

3. Clean weld area and apply touch-up paint to repaired area. See TM 43-0139.

4. Install rubber seal (2) on underside of hatch (3) with seal bead under four retaining strips (1). Bend retaining strips over seal bead.

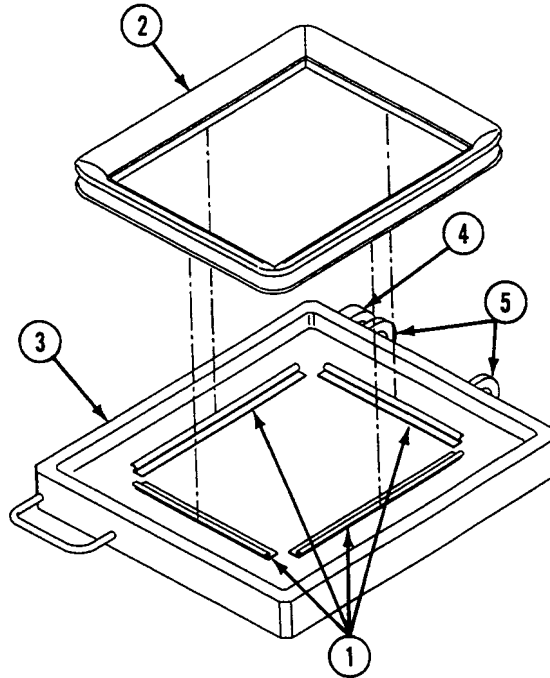
**FOLLOW-THROUGH STEPS**

1. Install hopper hatch on carrier (see your -20).

END OF TASK

**REPLACE COMMANDER'S CUPOLA (M113A3, M1059A3,
M1064A3, AND M58 ONLY)**

0050 00

THIS WORK PACKAGE COVERS:

Removal (page 0050 00-2).
Installation (page 0050 00-3).

INITIAL SETUP:

Maintenance Level

Direct Support

Tools and Special Tools

General Mechanic's Tool Kit (WP 0120 00, Item 62)
Sling (WP 0120 00, Item 52)
Torque Wrench (WP 0120 00, Item 75)
Lifting device with rated lift capability of at least 300
lb (136 kg)

Materials/Parts

Lifting cable

Personnel Required

Track Vehicle Repairer 63H10
Helper (H)

References

See your -10

Equipment Condition

Engine stopped (see your -10)
Carrier blocked (see your -10)

REPLACE COMMANDER'S CUPOLA (M113A3, M1059A3, M1064A3,
AND M58 ONLY) — Continued

0050 00

REMOVAL

1. Remove 12 screws (1) and washers (2) that hold commander's cupola (3) to carrier top deck.

WARNING



Damaged lifting slings can fail with load. Soldiers can be killed or injured. Inspect all slings TM 9-2350-277-20-2 before use. Do not use damaged slings.

2. Attach lifting device of at least 300 lb (136 kg) capacity to cupola (3). Lift cupola from carrier.

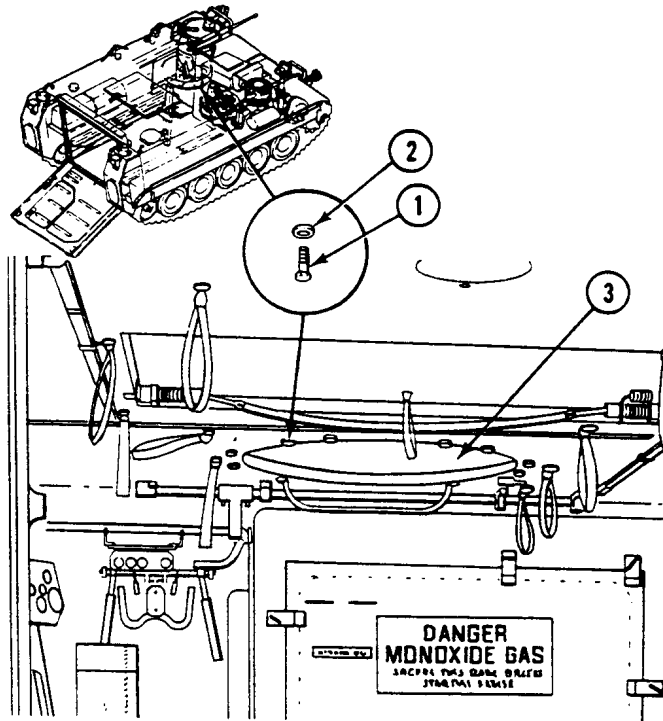

**REPLACE COMMANDER'S CUPOLA (M113A3, M1059A3, M1064A3,
AND M58 ONLY) — Continued**

0050 00

INSTALLATION

1. Align traverse lock pin with groove in cupola (1). Install commander's cupola (1) on carrier top deck ring.

NOTE

Rotation of cupola after installation should require no more than 150 lb-in (17 N·m) torque.

2. Secure cupola (1) to deck with 12 washers (2) and screws (3). TIGHTEN SCREWS TO 120 TO 130 LB-FT (162 TO 176 N·m) TORQUE.

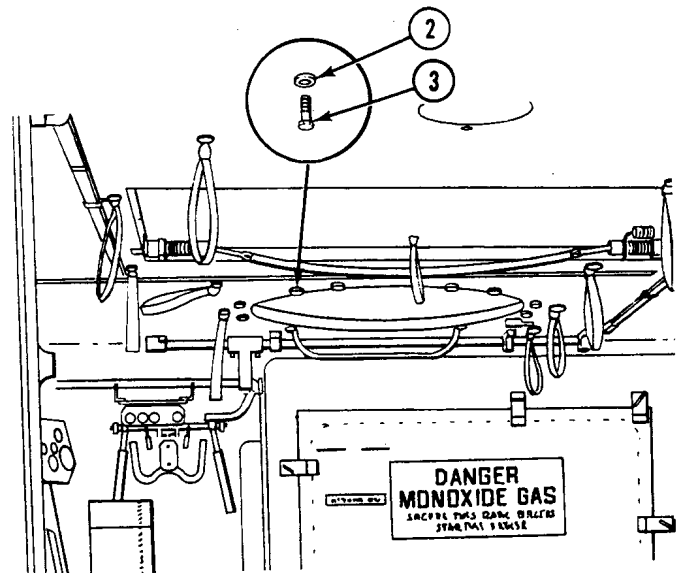
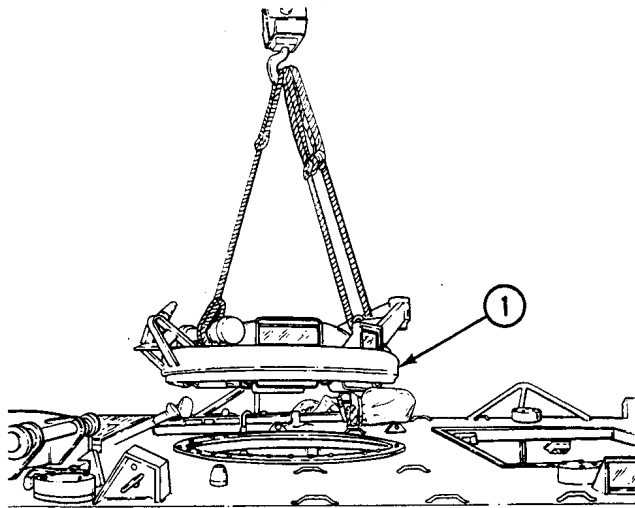
**END OF TASK**

**REPAIR COMMANDER'S CUPOLA (M113A3, M1059A3,
M1064A3, AND M58 ONLY)**

0051 00

THIS WORK PACKAGE COVERS:

- Removal (page 0051 00-2).
 - Installation (page 0051 00-10).
-

INITIAL SETUP:

Maintenance Level

Direct Support

Tools and Special Tools

- General Mechanic's Tool Kit (WP 0120 00, Item 62)
- Sling (WP 0120 00, Item 52)
- Torque Wrench (WP 0120 00, Item 75)
- Lifting device with rated lift capability of at least 300 lb (136 kg)

Materials/Parts

- Adhesive (WP 0122 00, Item 1)
- Clip
- Cotter pin
- Drive screw (3)
- Grease

Materials/Parts

- Locknut (2)
- Locknut
- Lockwasher (18)
- Seal
- Spring pin
- Spring pin

Personnel Required

- Track Vehicle Repairer 63H10
- Helper

References

- See your -10

Equipment Condition

- Engine stopped (see your -10)
 - Carrier blocked (see your -10)
 - Ramp lowered (see your -10)
-

REMOVAL

WARNING

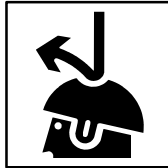

Commander's hatch cover may spring up and injure you. Open hatch cover and support in vertical position.

1. Remove two locknuts (1), washers (2), screws (3), and retainer (4) from cupola bracket (5). Discard locknuts.
2. Support cover (6). Remove 12 springs (7), shield (8), two fiber washers (9), and cover from cupola.
3. Remove locknut (10) and screw (11) from cover (6). Discard locknut.
4. Pry up end of seal (12) and remove from cover (6). Discard seal.

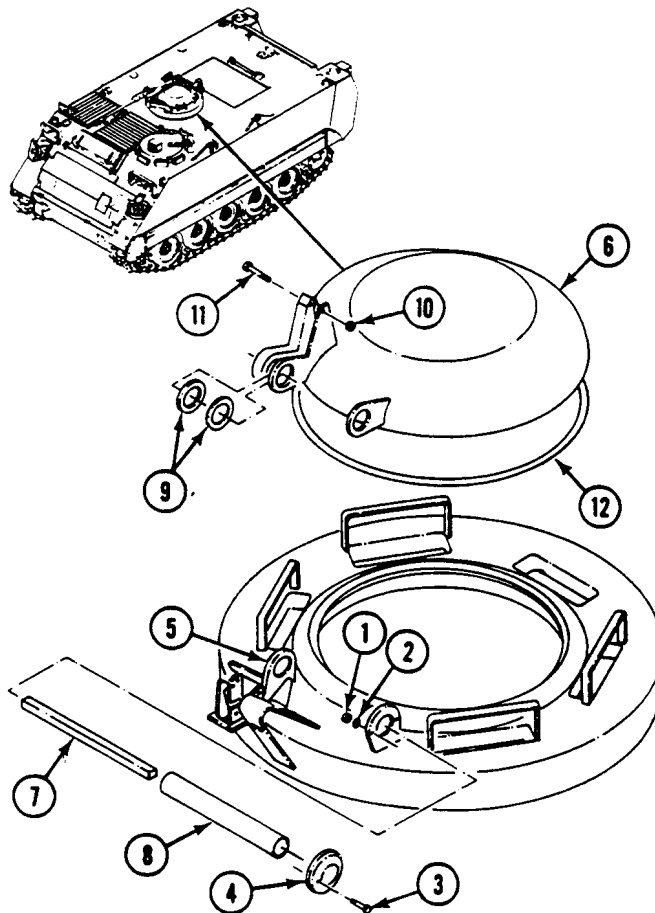

REPAIR COMMANDER'S CUPOLA (M113A3, M1059A3, M1064A3, AND M58 ONLY) — Continued

0051 00

5. Open both ends of hook (1). Remove hook from chain (2) and cupola bracket.
6. Remove tube (3) from chain (2).
7. Open both ends of hook (4). Remove hook from chain (2) and safety pin (5).

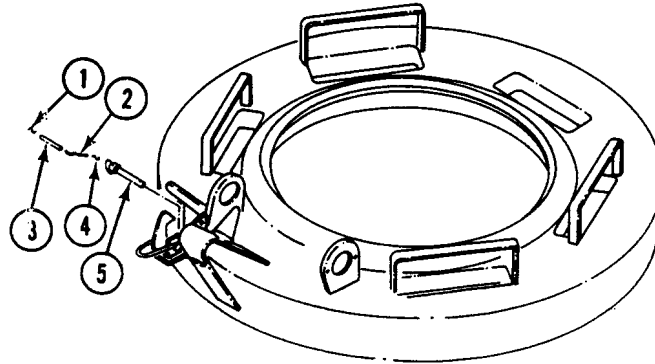

8. Remove locknut (6), two washers (7), spring (8), two spacers (9), hook (10), and screw (11) from cupola.
9. Remove nut (12), washers (13), bumper (14), and washer(s) (15) from cupola bracket.

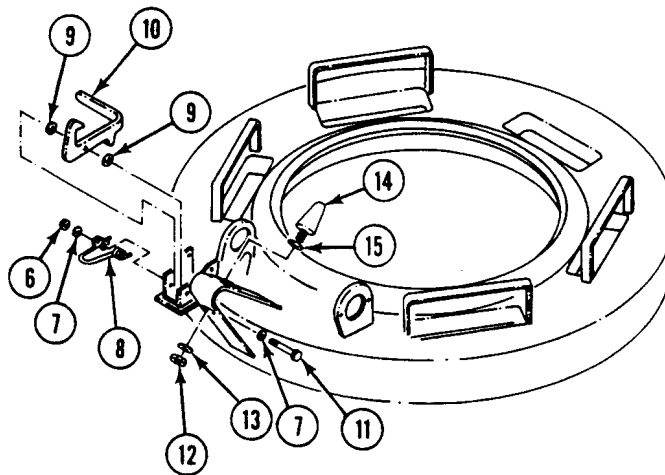

10. Remove four screws (16), washers (17), and machine gun mount (18) from commander's cupola.

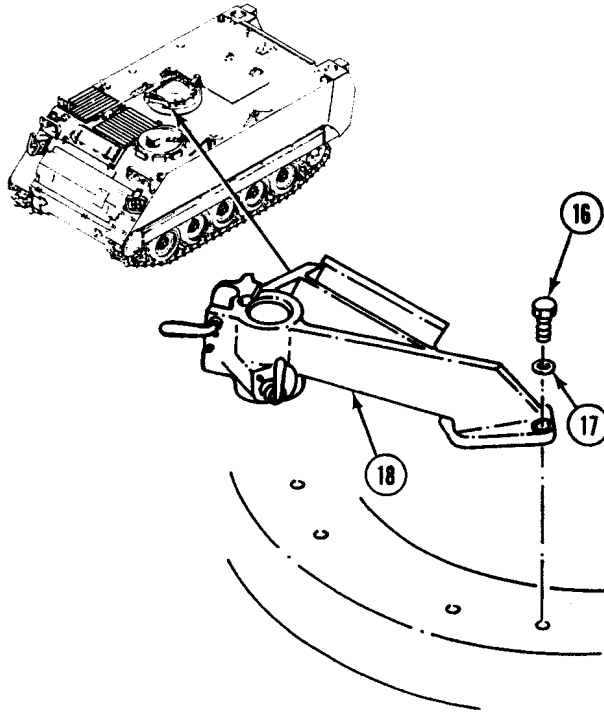

11. Remove two screws (19), washers (20), and brake assembly (21) from commander's hatch.

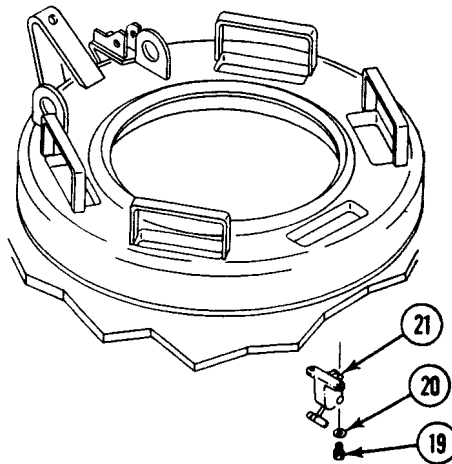

REPAIR COMMANDER'S CUPOLA (M113A3, M1059A3, M1064A3, AND M58 ONLY) — Continued

0051 00

12. Remove spring pin (1) and handle (2) from pin (3). Discard spring pin.
13. Remove bushing (4), washer(s) (5), pin (3), and spring (6) from commander's hatch.

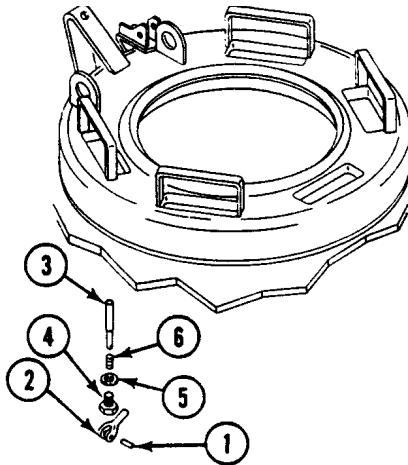

14. Remove cotter pin (7) from headed pin (8). Discard cotter pin.
15. Remove pin (8), spring (9), and catch (10) from support (11).
16. Remove two screws (12), washers (13), support (11), and shim(s) (14) from hull.
17. Remove two screws (15), washers (16), and striker (17) from cupola cover.

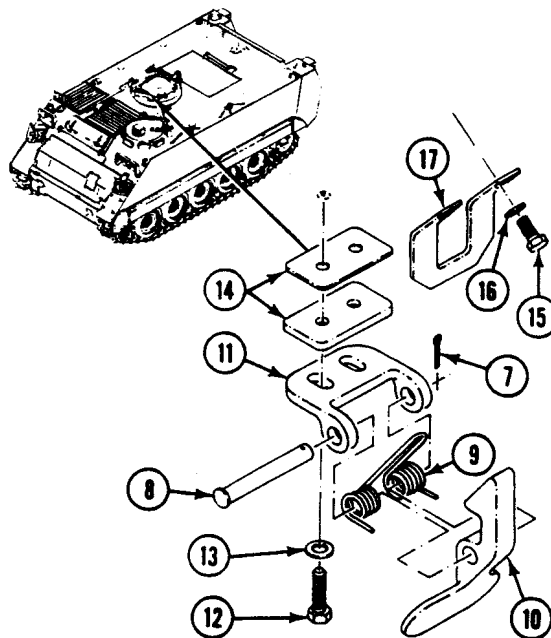

18. Remove heads of three drive screws (18) and clip (19) from cupola (20).

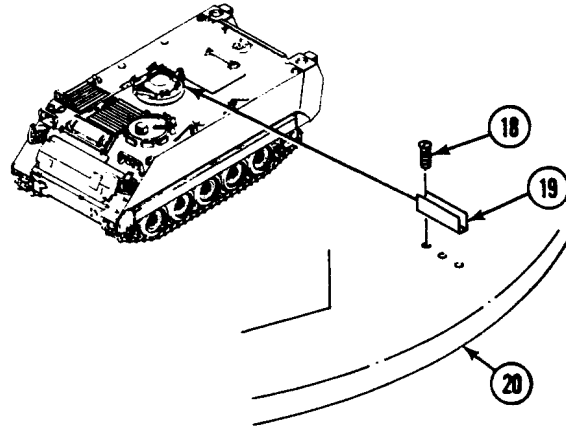

NOTE

There are five vision block locks and five seals on the commander's hatch. All are removed the same way.

NOTE

Commander's center vision block is held in place by two thumbscrews.

19. Remove thumbscrew (21) from arm (22).
 20. Remove spring pin (23) from arm (22). Discard spring pin.
 21. Remove arm (22) and washer (24) from hull bracket.
 22. Scrape seal (25) from vision block opening.

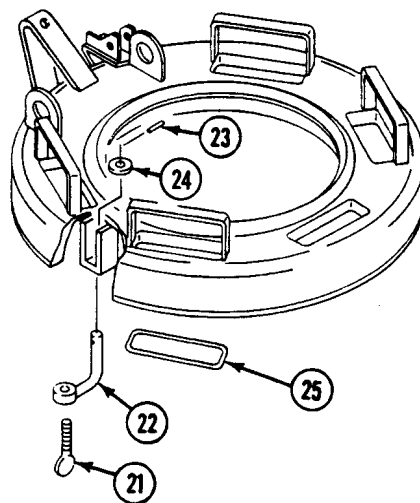

REPAIR COMMANDER'S CUPOLA (M113A3, M1059A3, M1064A3, AND M58 ONLY) — Continued

0051 00

23. Remove two screws (1), washers (2), and handle (3) from commander's hatch.
24. Remove six screws (4), washers (5), and pad (6) from commander's hatch.

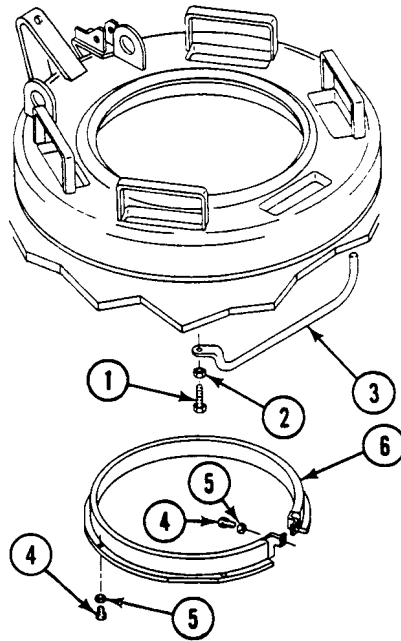

25. Remove 12 screws (7) and washers (8) that hold commander's cupola (9) to carrier top deck.

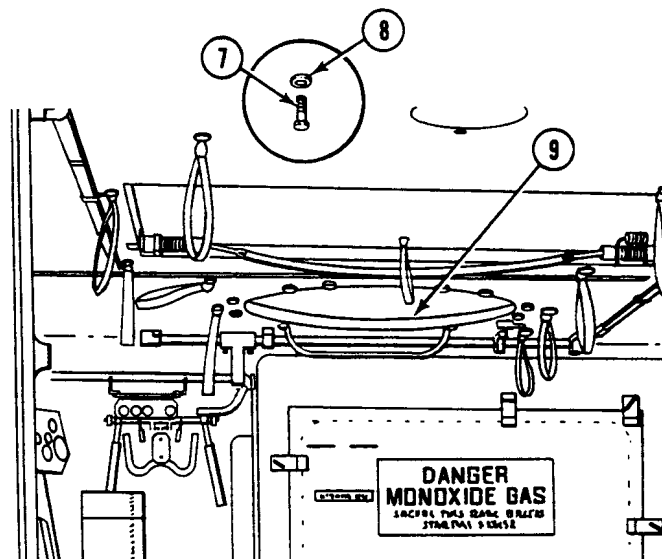

WARNING



Damaged lifting slings can fail with load. Soldiers can be killed or injured. Inspect all slings TM 9-2350-277-20-2 before use. Do not use damaged slings.

26. Attach lifting device to cupola (9). Lift cupola from carrier.

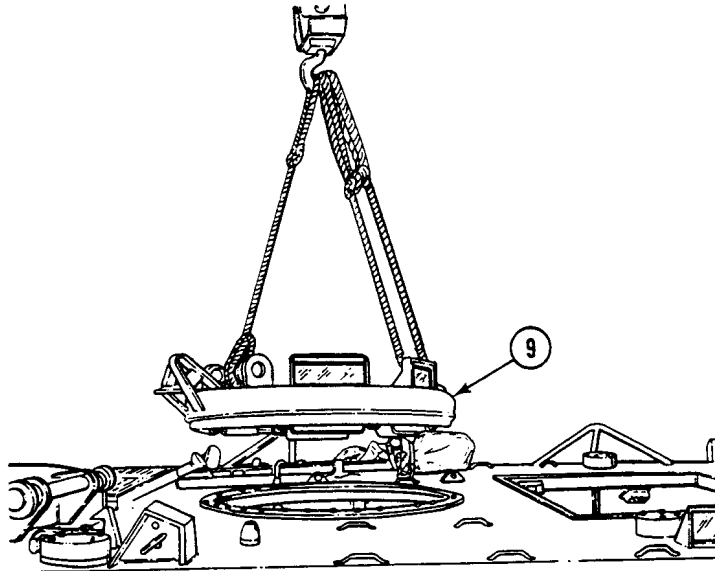

27. Invert cupola. Remove 18 socket head screws (1), lockwashers (2), and outer race (3) from hatch (4). Discard lockwashers.

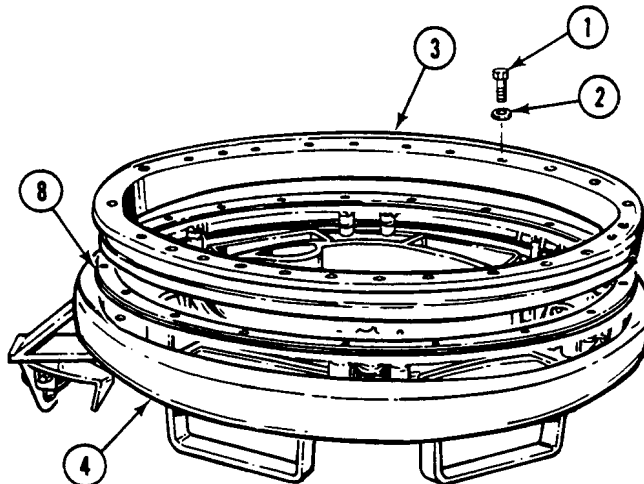

NOTE

Separators are like bearings except for size and color. Ball bearings are slightly larger than separators and are white or cream color. Separators may be any dark color.

28. Remove 140 ball bearings (5), 146 separators (6), and six bearing blocks (7) from inner race (8). Remove inner race from hatch (4).

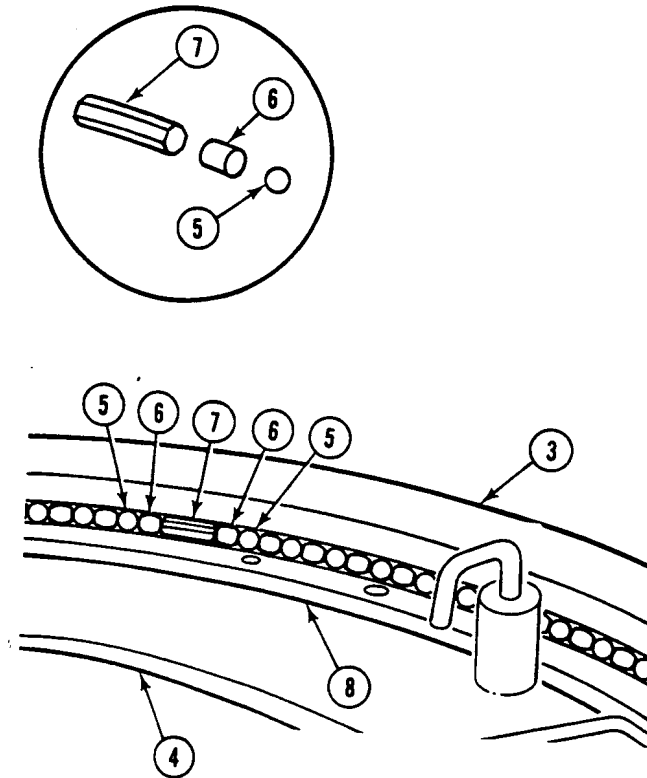

INSTALLATION

1. Invert new hatch (4).

NOTE

If one ball bearing or separator needs to be replaced, all ball bearings and separators must be replaced.

2. Install inner race (8) on hatch (4).

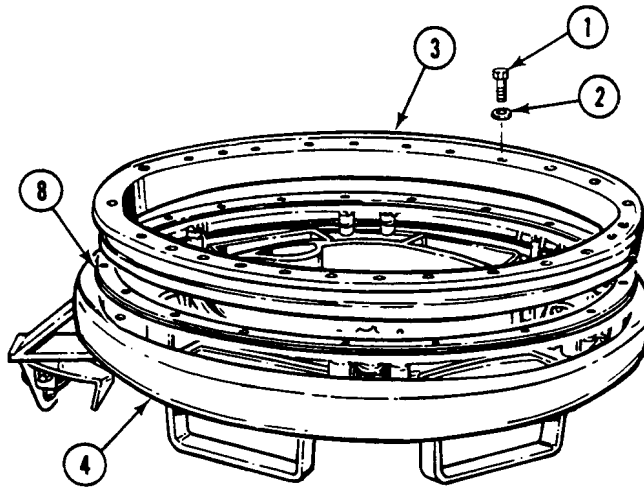
**CAUTION**

Improper installation will cause binding, resulting in bearing failure. Bearing block (7) concave surface must face toward cupola center.

Do not use talcum or other powder to reduce friction. When talcum is exposed to moisture, a chalky substance will form, causing binding.

NOTE

Alternately, install 24 separators (6) and 23 ball bearings (5) between bearing blocks (7). One separator is to be installed on each side of each bearing block. A maximum number of sets (one ball and one spacer per set) is needed between any two blocks. The number of sets in each space between blocks must not differ by more than one set.

3. Install 140 ball bearings (5), 146 separators (6), and six bearing blocks (7) in groove of inner race (8).

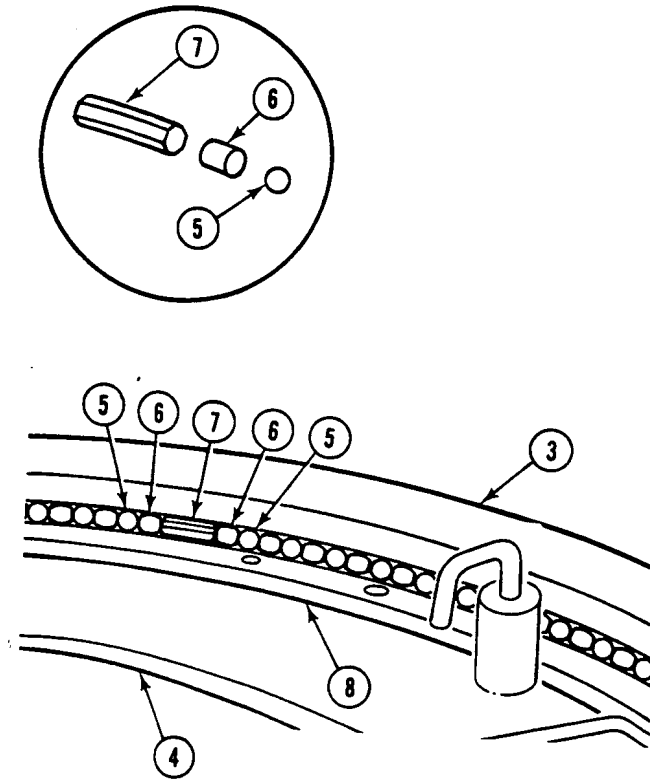

NOTE

The outer race and inner race must be aligned correctly so that the traverse lock pin will fit.

4. Install outer race (3) on hatch (4). Place large unthreaded hole in outer race directly above largest unthreaded hole in inner race (8).
5. Secure outer race (3) to inner race (8) with 18 new lockwashers (2) and socket head screws (1). TIGHTEN SCREWS TO 25 TO 34 LB-FT (34 TO 46 N·m) TORQUE.

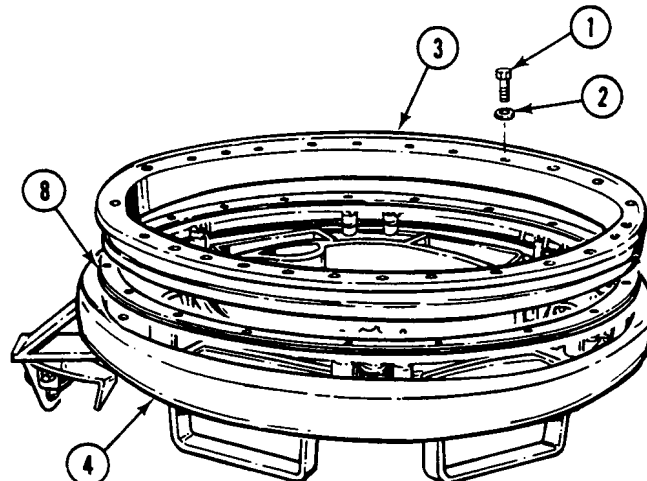

WARNING

Damaged lifting slings can fail with load. Soldiers can be killed or injured. Inspect all slings TM 9-2350-277-20-2 before use. Do not use damaged slings.

6. Align traverse lock pin with groove in cupola (9). Install commander's cupola on carrier top deck ring.

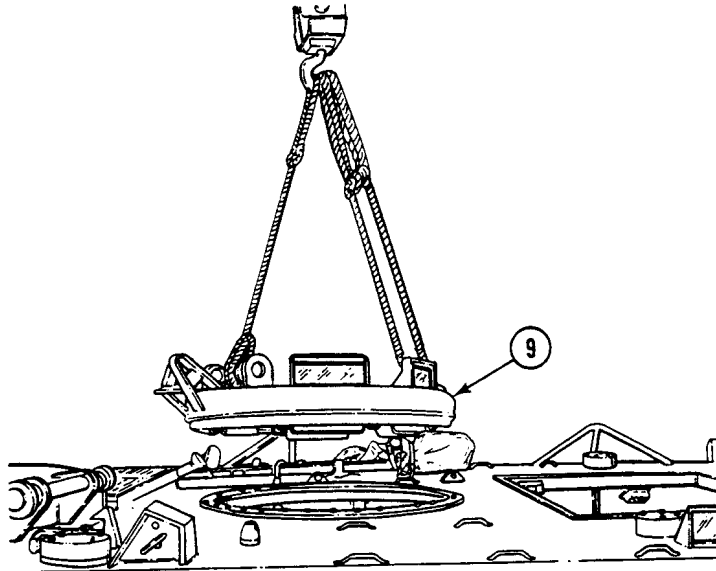
**NOTE**

Rotation of cupola after installation should require no more than 150 lb-in (17 N·m) torque.

7. Secure cupola (9) to deck with 12 washers (8) and screws (7). TIGHTEN SCREWS TO 120 TO 130 LB-FT (162 TO 176 N·m) TORQUE.

REPAIR COMMANDER'S CUPOLA (M113A3, M1059A3, M1064A3, AND M58 ONLY) — Continued

0051 00

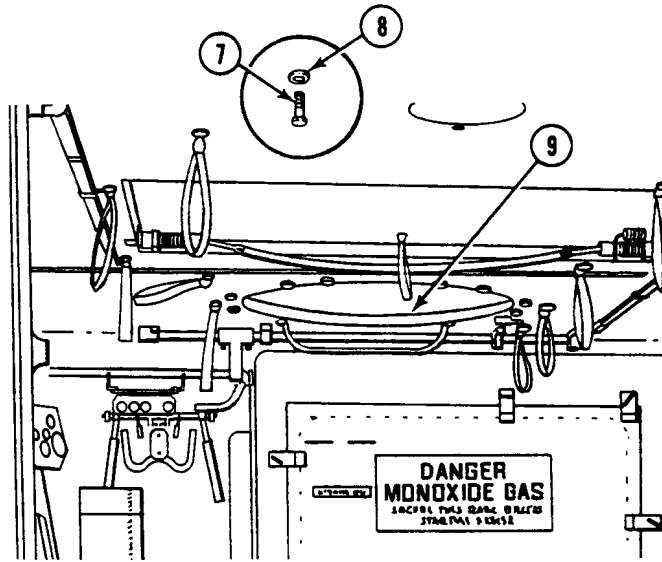

8. Align pad (6) with holes in commander's hatch. Secure with six washers (5) and screws (4).
9. Align handle (3) with commander's hatch. Secure with two washers (2) and screws (1). TIGHTEN SCREWS TO 120-130 LB-FT (162-176 N·m) TORQUE.

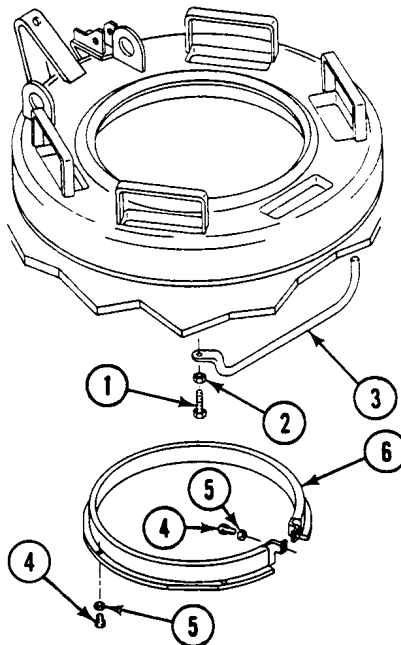

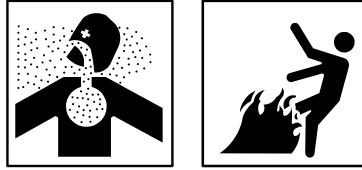
WARNING

Adhesive, primer, sealant compounds, and isopropyl alcohol are toxic and flammable. These compounds are toxic to eyes, skin, and respiratory tract. Continued exposure can make you dizzy and irritate your eyes and throat.

Always use in well ventilated areas, away from heat, sparks, and flames. Do not breathe fumes. Do not allow into contact with skin and eyes. Use goggles or face shield and protective gloves.

NOTE

Surface on seal marked **BOND THIS SIDE** should be glued to hull.

10. Apply adhesive to cleaned mating surface around vision block opening. Allow adhesive to become tacky. Install seal (25) on hull.
11. Install arm (22) and washer (24) in hull bracket. Secure with new spring pin (23).
12. Install thumbscrew (21) in arm (22). Deform first thread of thumbscrew to prevent easy removal.

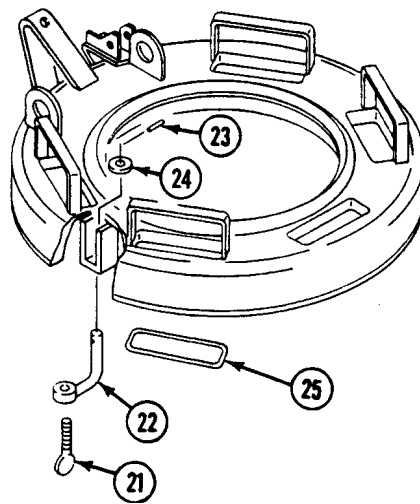
**NOTE**

Do not drill deeper than length of drive screw.

13. Drill three new 3/32 inch holes close to old drive screw holes. Use new clip (19) for template.

14. Align clip (19) on three new holes. Secure with three new drive screws (18).

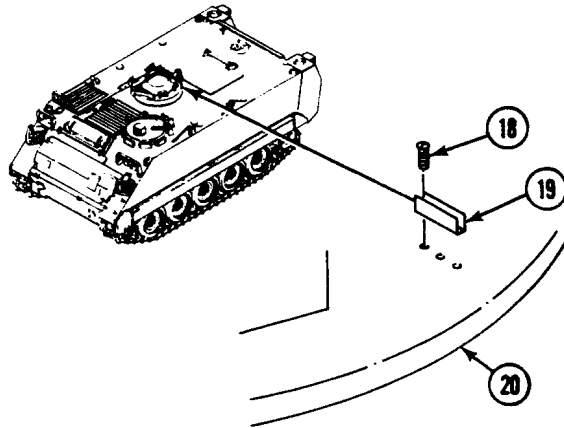

NOTE

Use the least number of washers needed to release pin in unlocked position.

15. Install spring (6), pin (3), washers (5), and bushing (4) in commander's hatch.
 16. Align handle (2) with pin (3). Secure with new spring pin (1).

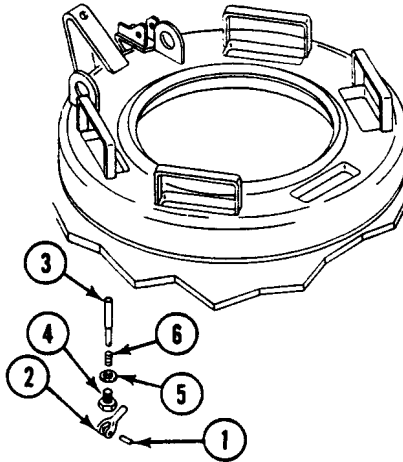

17. Align brake assembly (21) with holes to commander's hatch. Secure with two washers (20) and screws (19).

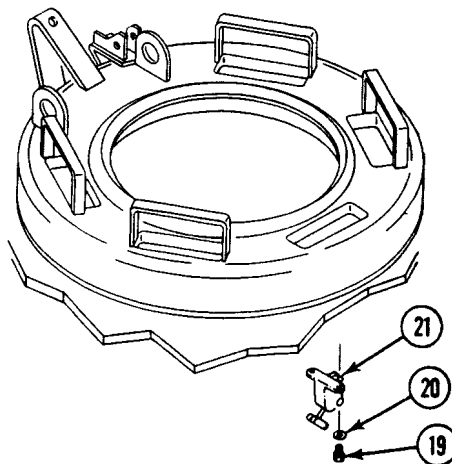

18. Place machine gun mount (18) on commander's cupola. Secure with four washers (17) and screws (16).

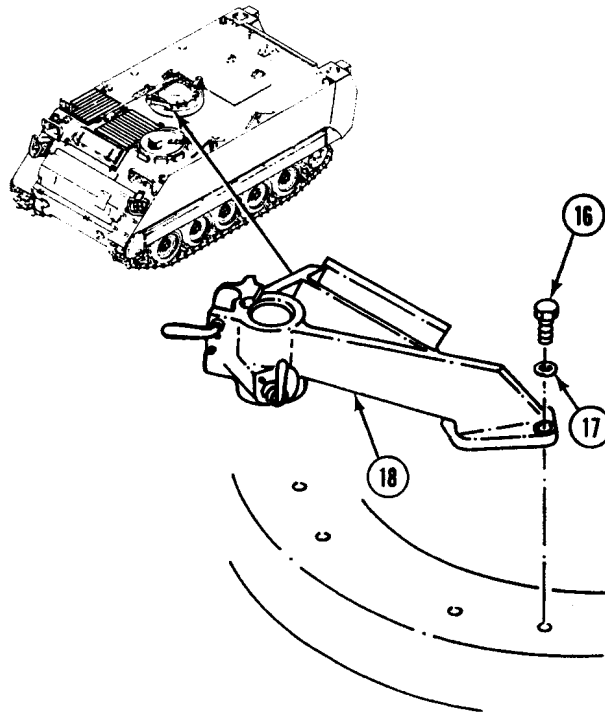
**NOTE**

Install washer(s), as needed, to compress bumper 1/4 inch (6 mm) when hold-open hook is engaged.

19. Install washer(s) (15) and bumper (14) in cupola bracket. secure with washer (13) and nut (12).
20. Align hook (10), two spacers (9), spring (8) and two washers (7) with cupola bracket. Secure with screw (11) and locknut (6).

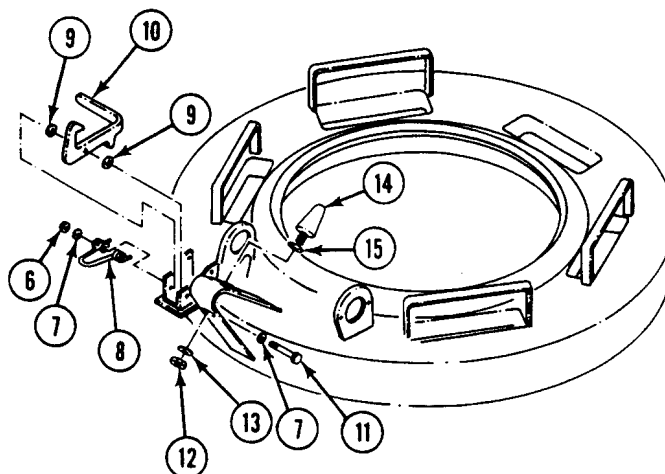

21. Install hook (4) in safety pin (5) and chain (2). Squeeze both ends of hook to secure.

REPAIR COMMANDER'S CUPOLA (M113A3, M1059A3, M1064A3, AND M58 ONLY) — Continued

0051 00

22. Install tube (3) on chain (2).
23. Install hook (1) in chain (2) and cupola bracket. Squeeze both ends of hook to secure.

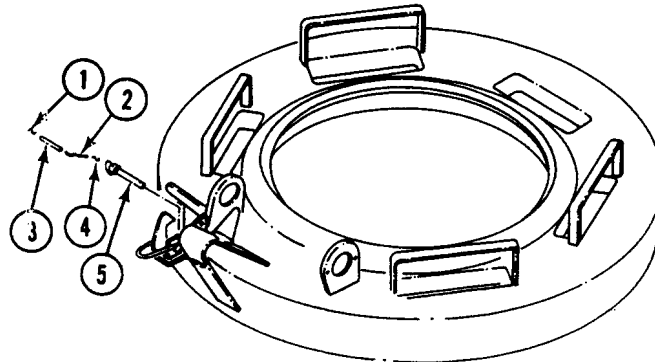

24. Place new seal (12) over retaining groove in cover (6). Press seal into place. Trim end of seal if needed.
25. Install screw (11) in cover (6). Secure with new locknut (10).
26. Align cover (6) with cupola brackets. Install two fiber washers (9) and shield (8).
27. Apply light coat of grease to each spring (7). Install 12 springs on shield (8).
28. Place cover (6) in vertical position. Install retainer (4) on cupola bracket. Secure with two screws (3), washers (2), and new locknuts (1).

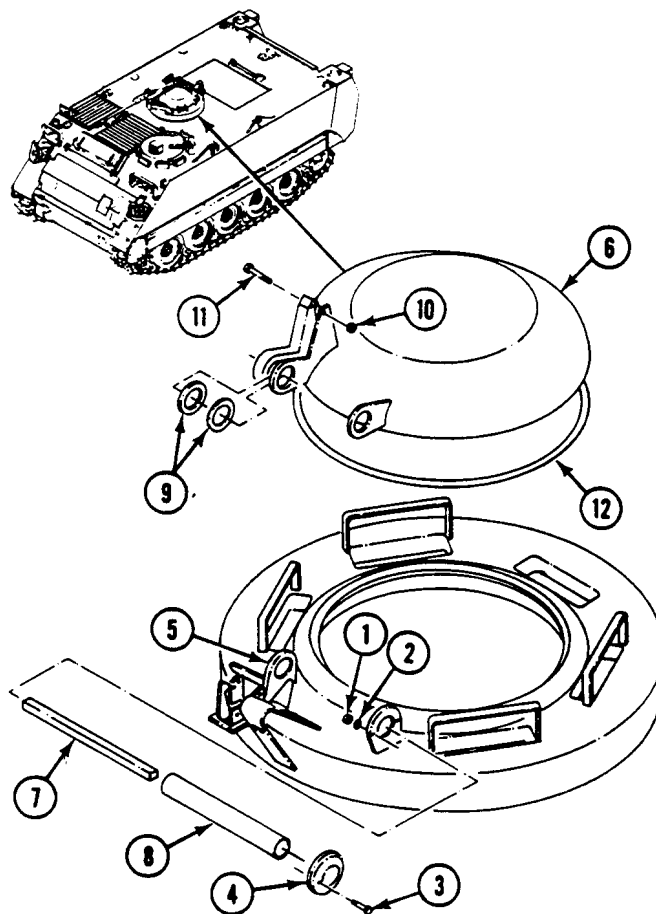

0051 00-17

REPAIR COMMANDER'S CUPOLA (M113A3, M1059A3, M1064A3, AND M58 ONLY) — Continued

0051 00

29. Align striker (17) with holes in cupola cover. Secure with two washers (16) and screws (15).
30. Place shim(s) (14) and support (11) on hull. Secure with two washers (13) and screws (12). Do not torque screws at this time.
31. Align catch (10) and spring (9) with support (11). Secure with headed pin (8) and new cotter pin (7).

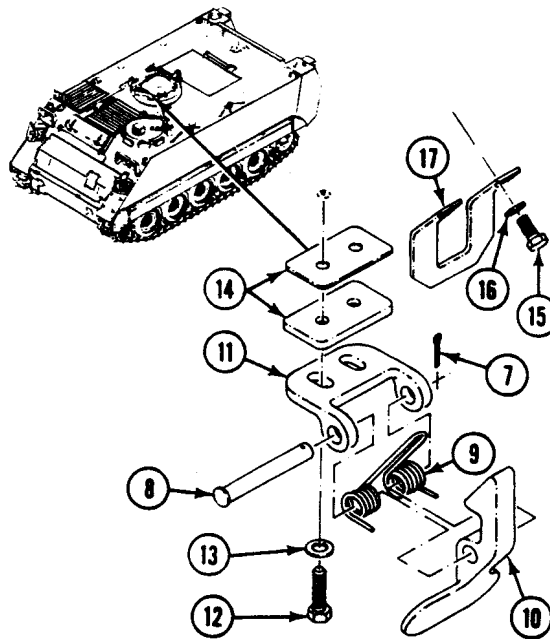

NOTE

Commander's cupola cover should latch tightly with firm latching action.

32. To increase pressure of catch (10) on striker (17), add shim(s) (14), as needed, between support (11) and hull.
33. To decrease pressure of catch (10) on striker (17), remove shim(s) (14), as needed, from between support (11) and hull.
34. TIGHTEN TWO SCREWS (12) TO 25-30 LB-FT (34-41 N·m) TORQUE.

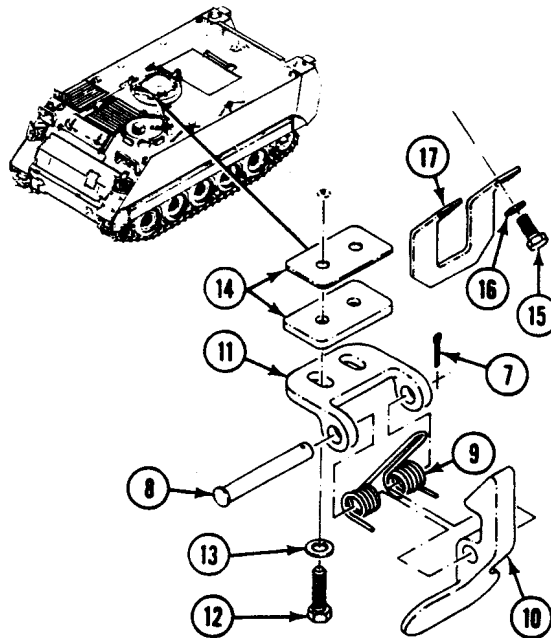

END OF TASK

REPAIR COMMANDER'S CUPOLA BEARING (M113A3, M1059A3, M1064A3, AND M58 ONLY)

0052 00

THIS WORK PACKAGE COVERS:

Removal (page 0052 00-1).
 Installation (page 0052 00-2).

INITIAL SETUP:

Maintenance Level

Direct Support

Materials/Parts

Lockwasher (18)

Personnel Required

Track Vehicle Repairer 63H10

Tools and Special Tools

General Mechanics Tool Kit (WP 0120 00, Item 62)
 Torque Wrench (WP 0120 00, Item 75)

Equipment Condition

Commander's cupola removed (WP 0050 00)

REMOVAL

1. Turn cupola over. Remove 18 socket head screws (1), lockwashers (2), and outer race (3) from hatch (4). Discard lockwashers.

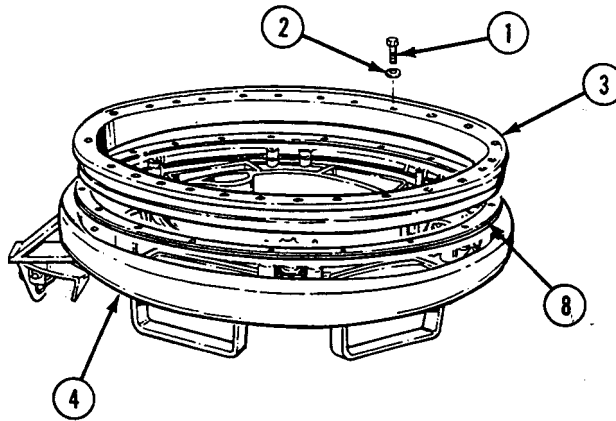

NOTE

Separators are like bearings except for size and color. Ball bearings are slightly larger than separators and are white or cream color. Separators may be any dark color.

- Remove 140 ball bearings (5), 146 separators (6), and 6 bearing blocks (7) from inner race (8). Remove inner race from hatch (4).

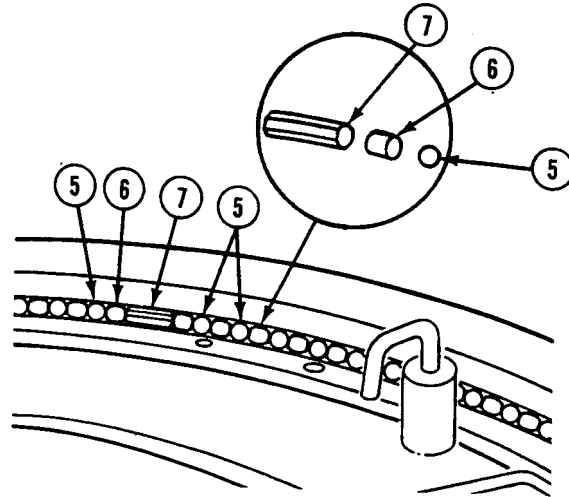

INSTALLATION

NOTE

If one ball bearing or separator needs to be replaced, all ball bearings and separators must be replaced.

- Install inner race (8) on hatch (4).

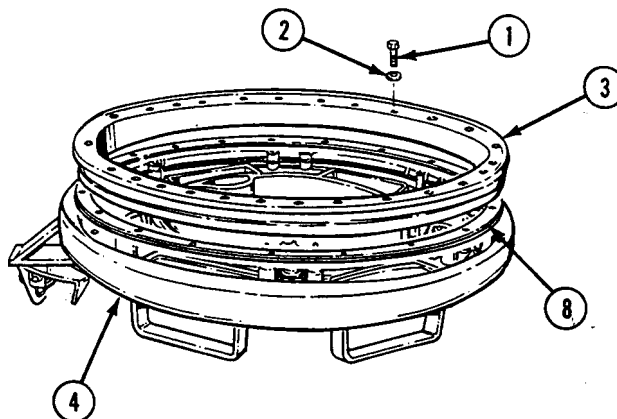

CAUTION

Improper installation will cause binding, resulting in bearing failure. Bearing block (7) concave surface must face toward cupola center.

Do not use talcum or other powder to reduce friction. When talcum is exposed to moisture, a chalky substance will form, causing binding.

NOTE

Alternately, install 24 separators (6) and 23 ball bearings (5) between bearing blocks (7). One separator (6) is to be installed on each side of each bearing block (7). A maximum number of sets (one ball and one spacer per set) is needed between any two blocks. The number of sets in each space between blocks must not differ by more than one set.

2. Install 140 ball bearings (5), 146 separators (6), and 6 bearing blocks (7) in groove of inner race (8).

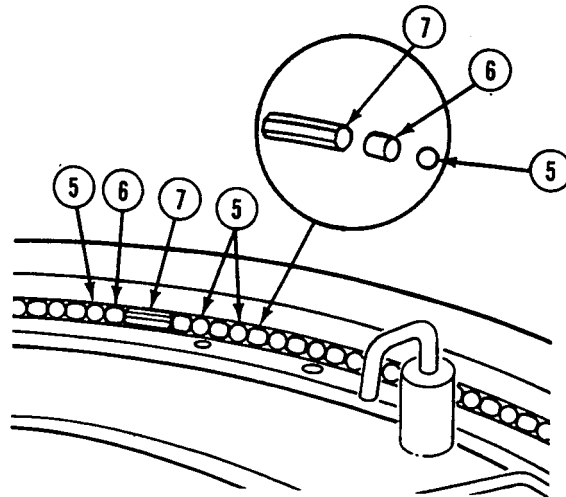
**NOTE**

The outer race and inner race must be aligned correctly so that the traverse lock pin will fit.

3. Install outer race (3) on hatch (4). Place large unthreaded hole in outer race (3) directly above largest unthreaded hole in inner race (8).

REPAIR COMMANDER'S CUPOLA BEARING (M113A3, M1059A3, M1064A3, AND M58 ONLY) — Continued

0052 00

4. Secure outer race (3) to inner race (8) with 18 new lockwashers (2) and socket head screws (1). TIGHTEN SCREWS TO 25-34 LB-FT (34-46 N·m) TORQUE.

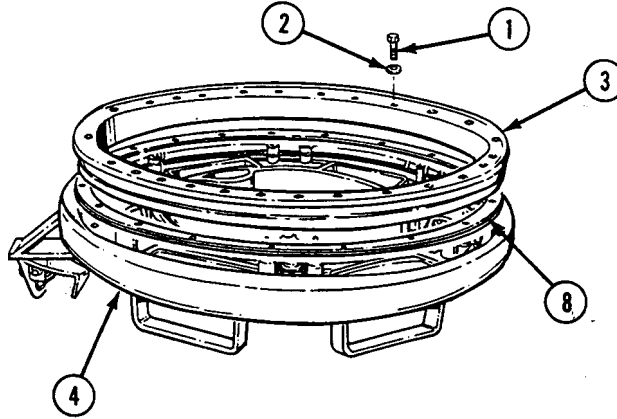
**FOLLOW-THROUGH STEPS**

1. Install commander's cupola (WP 0050 00).

END OF TASK

REPAIR COMMANDER'S CUPOLA COVER HINGES (M113A3, M1059A3, M1064A3, AND M58 ONLY)

0053 00

THIS WORK PACKAGE COVERS:

Removal (page 0053 00-1).
 Installation (page 0053 00-2).

INITIAL SETUP:

Maintenance Level

Direct Support

Tools and Special Tools

Metal Worker's Tool Kit (WP 0120 00, Item 63)
 Trailer Mounted Welding Shop (WP 0120 00, Item 69)
 Sander Spindle Adapter (WP 0120 00, Item 1)
 Welder's Gloves (WP 0120 00, Item 18)
 Industrial Goggles (WP 0120 00, Item 19)
 Welder's Helmet (WP 0120 00, Item 21)
 Electric Disc Sander (WP 0120 00, Item 46)
 Arc Welding Machine (WP 0120 00, Item 68)

Materials/Parts

Welding electrode (WP 0122 00, Item 35)

Personnel Required

Metal Worker 44B10

References

See your -20
 TM 43-0139
 TM 9-237

Equipment Condition

Commander's cupola cover removed (see your -20)

REMOVAL

WARNING

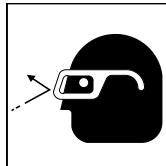

Metal chips and grinding dust can cause eye injury. Wear goggles and gloves.

1. Remove and discard broken hinge part (1), (2), or (3) from cover (4).
2. Use a machinist hammer and a cold chisel to chip off remaining part of bad hinge from cover.

REPAIR COMMANDER'S CUPOLA COVER HINGES (M113A3, M1059A3, M1064A3, AND M58 ONLY) — Continued

0053 00

3. Use a disc sander to sand chipped area smooth and remove any hard coating from weld area.

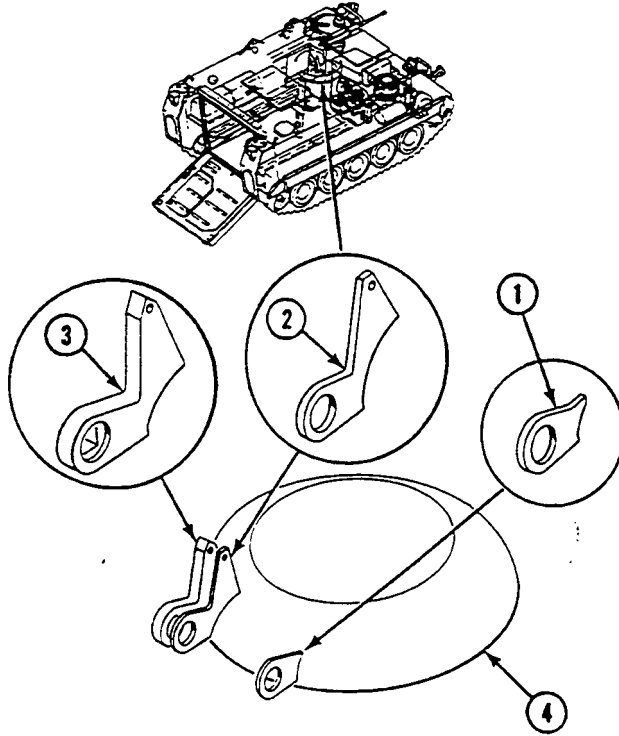
**INSTALLATION**

1. Clamp or tack weld new hinge(s) (1), (2), or (3) on cover (4). Set cover on commander's cupola. Check alignment of cover hinges with hinges on cupola.
2. Make sure hinges are aligned and spaced as shown.
3. Weld hinges to cover. See TM 9-237. Use electrode type 5356.
4. If hinge (3) has been replaced, weld in a new torsion bar cover (5).

REPAIR COMMANDER'S CUPOLA COVER HINGES (M113A3, M1059A3, M1064A3, AND M58 ONLY) — Continued

0053 00

- Clean the weld area and apply touch-up paint to repaired area. See TM 43-0139.

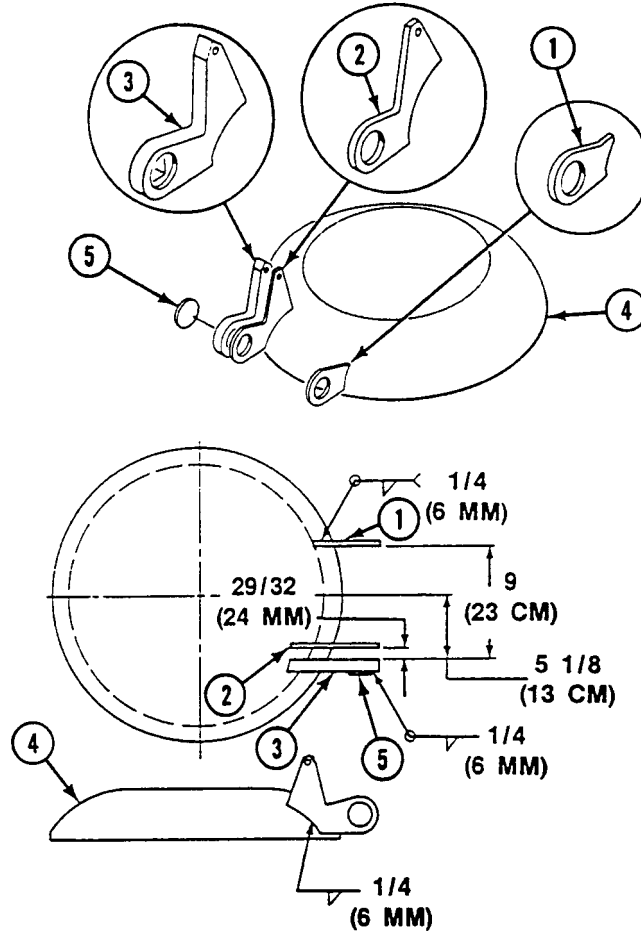

FOLLOW-THROUGH STEPS

- Install commander's cupola cover (see your -20).

END OF TASK

**REPAIR COMMANDER'S CUPOLA HINGES (M113A3, M1059A3, M1064A3,
AND M58 ONLY)**

0054 00

THIS WORK PACKAGE COVERS:

Removal (page 0054 00-1).
Installation (page 0054 00-3).

INITIAL SETUP:

Maintenance Level

Direct Support

Tools and Special Tools

Metal Worker's Tool Kit (WP 0120 00, Item 63)
Trailer Mounted Welding Shop (WP 0120 00, Item 69)
Sander Spindle Adapter (WP 0120 00, Item 1)
Welder's Gloves (WP 0120 00, Item 18)
Industrial Goggles (WP 0120 00, Item 19)
Welder's Helmet (WP 0120 00, Item 21)
Electric Disc Sander (WP 0120 00, Item 46)
Arc Welding Machine (WP 0120 00, Item 68)

Materials/Parts

Welding electrode (WP 0122 00, Item 35)

Personnel Required

Metal Worker 44B10

References

TM 43-0139
TM 9-237

Equipment Condition

Commander's cupola cover removed (see your -20)

REMOVAL

WARNING

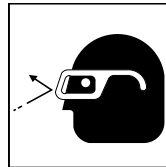

Metal chips and grinding dust can cause eye injury. Wear goggles and gloves.

1. Remove and discard broken hinge part (1), (2), or (3) from commander's cupola (4).
2. Use a machinist hammer and a cold chisel to chip off remaining part of bad hinge from cupola.

3. Use a disc sander to sand chipped area smooth and remove any hard coating from weld area.

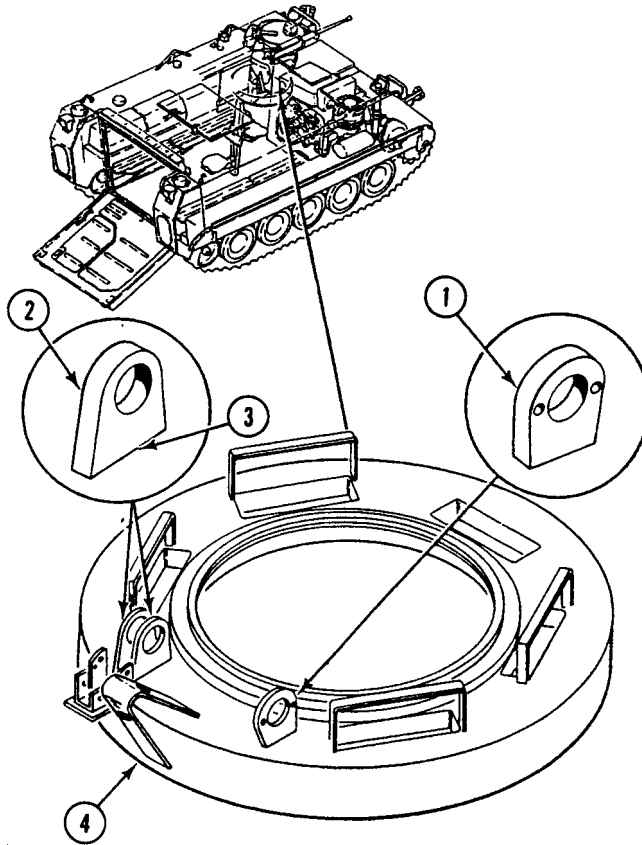

REPAIR COMMANDER'S CUPOLA HINGES (M113A3, M1059A3, M1064A3, AND M58 ONLY) — Continued

0054 00

INSTALLATION

1. Clamp or tack weld new hinge(s) parts (1), (2), or (3) on hatch (4). Set cover on commander's cupola. Check alignment of cover hinges with hinges on hull.
2. Make sure hinges (1), (2), or (3) are aligned and spaced as shown.
3. Weld hinges (1), (2), or (3) to hatch (4). See TM 9-237. Use electrode type 5356.
4. Clean the weld area and apply touch-up paint to all bare metal. See TM 43-0139.

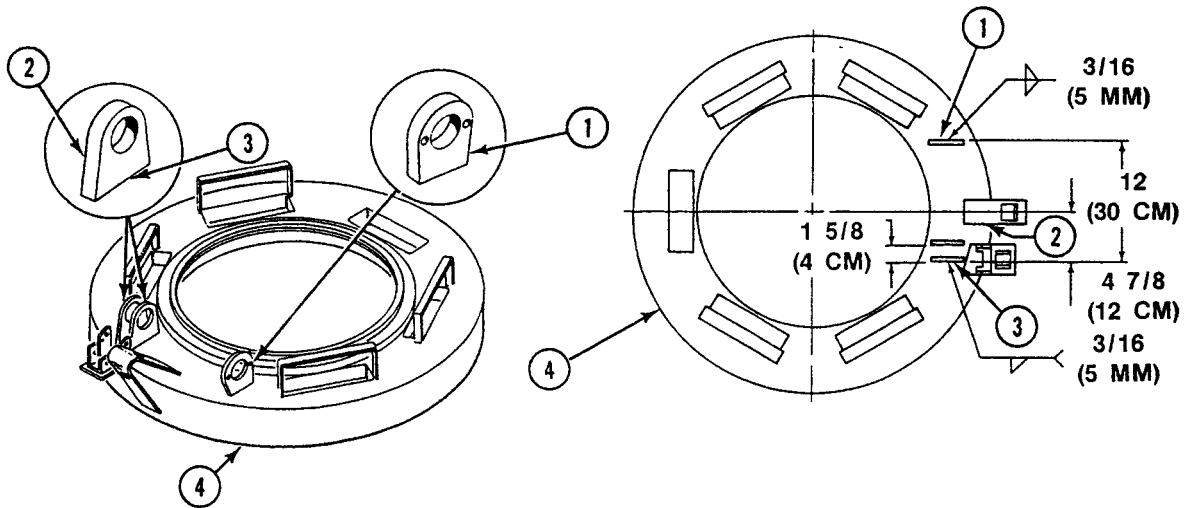

FOLLOW-THROUGH STEPS

1. Install commander's cupola cover on carrier (see your -20).

END OF TASK

REPAIR COMMANDER'S HATCH COVER HINGES (M577A3 AND M1068A3 ONLY)

0055 00

THIS WORK PACKAGE COVERS:

Removal (page 0055 00-1).
 Installation (page 0055 00-2).

INITIAL SETUP:

Maintenance Level

Direct Support

Personnel Required

Metal Worker 44B10

Tools and Special Tools

Metal Worker's Tool Kit (WP 0120 00, Item 63)
 Trailer Mounted Welding Shop (WP 0120 00, Item 69)
 Adapter (WP 0120 00, Item 1)
 Welder's Gloves (WP 0120 00, Item 18)
 Industrial Goggles (WP 0120 00, Item 19)
 Welder's Helmet (WP 0120 00, Item 21)
 Electrical Disc Sander (WP 0120 00, Item 46)

References

See your -20
 TM 43-0139
 TM 9-237

Materials/Parts

Welding Electrode (WP 0122 00, Item 35)
 Hinge

Equipment Condition

Commander's hatch cover removed from carrier
 (see your -20)
 Battery ground strap disconnected (see your -20)

REMOVAL

WARNING

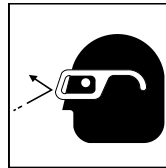

Metal chips and grinding dust can cause injury. Wear goggles and gloves.

1. Remove and discard broken hinge part (1), (2), or (3) from hatch cover (4).
2. Use a machinist's hammer and a cold chisel to chip off remaining part of bad hinge from hatch (4).

REPAIR COMMANDER'S HATCH COVER HINGES (M577A3 AND M1068A3 ONLY) —
Continued

0055 00

- Use a disc sander to sand chipped area smooth and remove any hard coating from weld area.

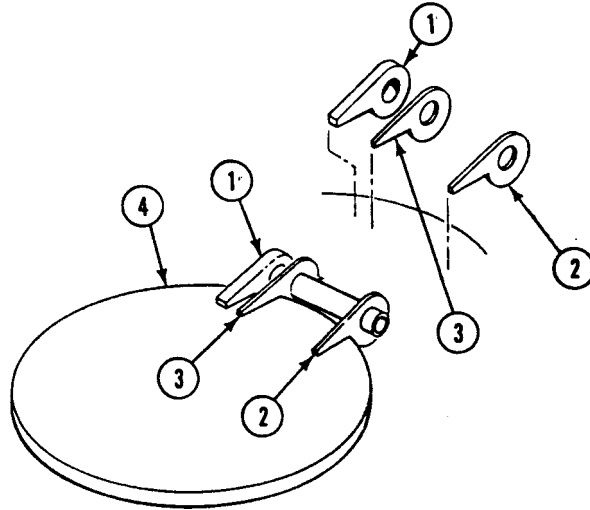

INSTALLATION

- Clamp or tack weld new hinge part (1), (2), or (3) on cover (4).
- Install cover (4) on hatch (see your -20).
- Check alignment of hinges (1), (2), or (3) on cover (4) with torsion bar shields and hinges on hull.
- Remove cover. Weld hinges (1), (2), or (3) to cover (4). See TM 9-237. Use electrode type 5356.
- Clean weld area and apply touch-up paint to repaired area. See TM 43-0139.

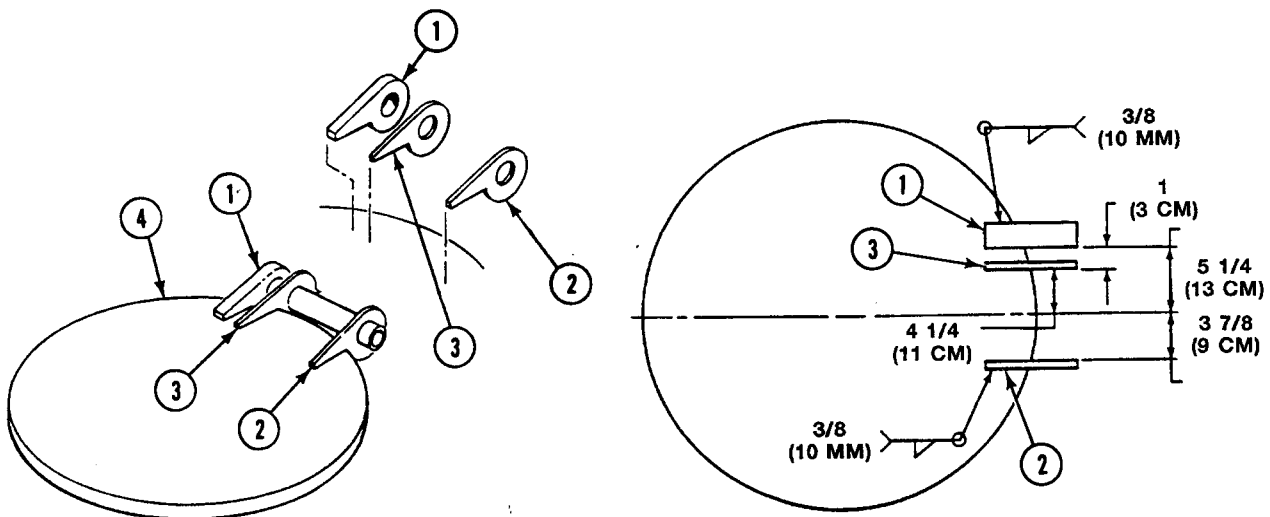

FOLLOW-THROUGH STEPS

- Install commander's hatch cover on carrier (see your -20).
- Connect battery ground strap (see your -20).

END OF TASK

REPAIR COMMANDER'S HATCH COVER HULL HINGES (M577A3 AND M1068A3 ONLY)

0056 00

THIS WORK PACKAGE COVERS:

Removal (page 0056 00-1).
 Installation (page 0056 00-2).

INITIAL SETUP:

Maintenance Level

Direct Support

Personnel Required

Metal Worker 44B10

Tools and Special Tools

Adapter (WP 0120 00, Item 1)
 Welder's Gloves (WP 0120 00, Item 18)
 Industrial Goggles (WP 0120 00, Item 19)
 Welder's Helmet (WP 0120 00, Item 21)
 Electrical Disc Sander (WP 0120 00, Item 46)
 Metal Worker's Tool Kit (WP 0120 00, Item 63)
 Trailer Mounted Welding Shop (WP 0120 00, Item 69)

References

See your -20
 TM 43-0139
 TM 9-237

Materials/Parts

Welding Electrode (WP 0122 00, Item 35)
 Hinge

Equipment Condition

Commander's hatch cover removed from carrier
 (see your -20)
 Battery ground strap disconnected (see your -20)

REMOVAL

WARNING

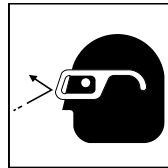

Metal chips and grinding dust can cause injury. Wear goggles and gloves.

1. Remove and discard broken hinge part (1), (2), or (3) from hull.
2. Use a machinist's hammer and a cold chisel to chip off remaining part of bad hinge (1), (2), or (3) from hull.

- Use a disc sander to sand chipped area smooth and remove any hard coating from weld area.

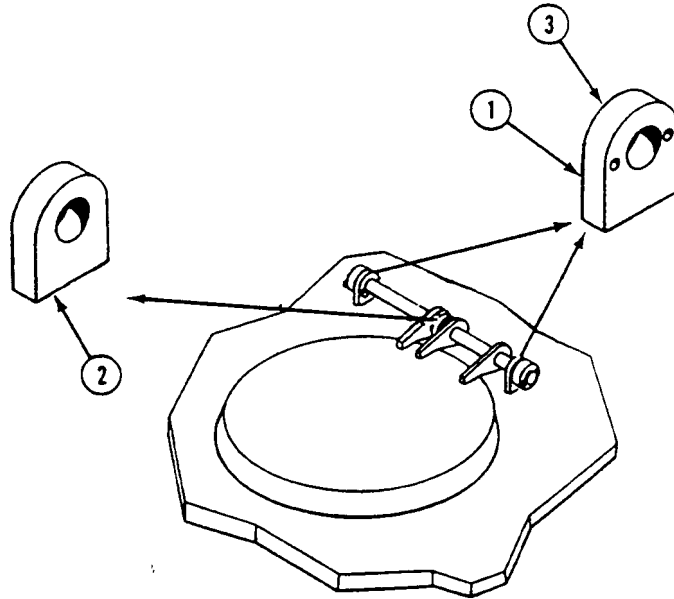

INSTALLATION

- Clamp or tack weld new hinge part (1), (2), or (3) on hull.
- Install cover on hatch (see your -20).
- Check alignment of hinges (1), (2), or (3) on cover with torsion bar shields and hinges on hull.
- Remove cover. Weld hinges (1), (2), or (3) to hull. See TM 9-237. Use electrode type 5356.
- Clean weld area and apply touch-up paint to repaired area. See TM 43-0139.

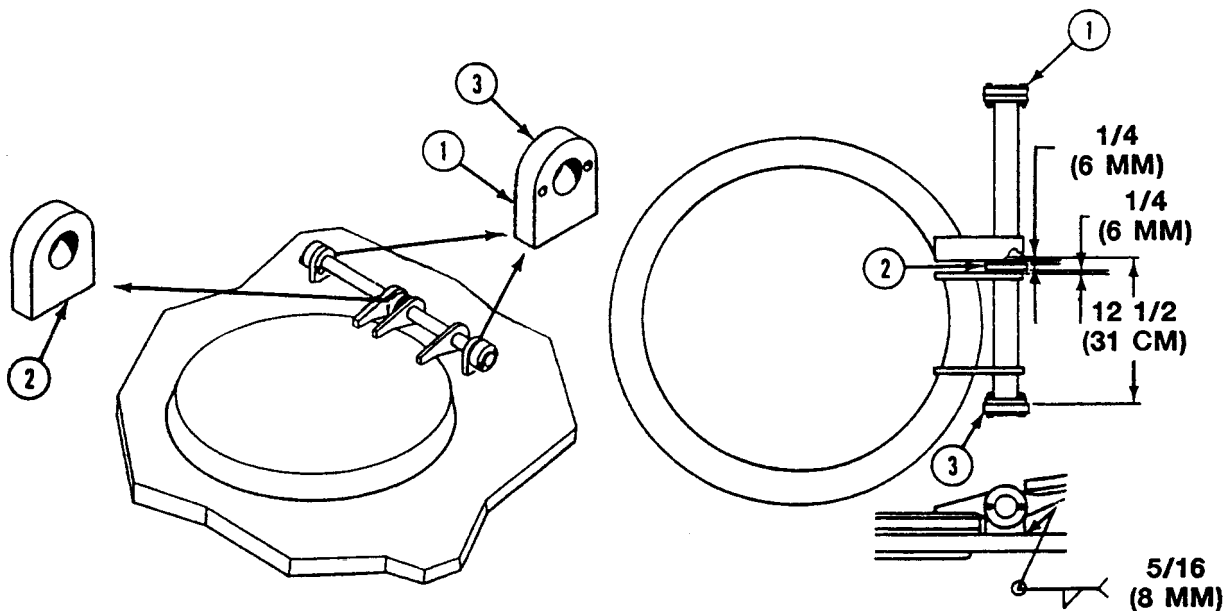

REPAIR COMMANDER'S HATCH COVER HULL HINGES (M577A3 AND M1068A3 ONLY)

0056 00

— Continued

FOLLOW-THROUGH STEPS

1. Install commander's hatch cover on carrier (see your -20).
2. Connect battery ground strap (see your -20).

END OF TASK

REPLACE RAMP ACCESS DOOR AND HINGES (M113A3 ONLY)

0057 00

THIS WORK PACKAGE COVERS:

Removal (page 0057 00-1).
 Installation (page 0057 00-3).

INITIAL SETUP:

Maintenance Level

Direct Support

Tools and Special Tools

General Mechanic's Tool Kit (WP 0120 00, Item 62)
 Torque wrench (WP 0120 00, Item 73)
 Lifting device with rated lift capability of at least 200 lbs
 (91 kg)

Personnel Required

Track Vehicle Repairer 63H10

Materials/Parts

Locknut (2)
 Shim (2)
 Shim (2)

References

See your -10
 See your -20

Equipment Condition

Ramp raised and locked (see your -10)
 Engine stopped (see your -10)

REMOVAL

WARNING



Door could fall and injure you. Make sure door is held by a lifting device before removing hinge screws.

1. Attach door (1) to a suitable lifting device.
2. Remove two screws (2) and locknuts (3) that secure ramp door (1) to four hinges (4)(5) on ramp. Remove door (1) from ramp. Discard locknuts.

3. Remove eight washers (6) from hinges (4)(5).

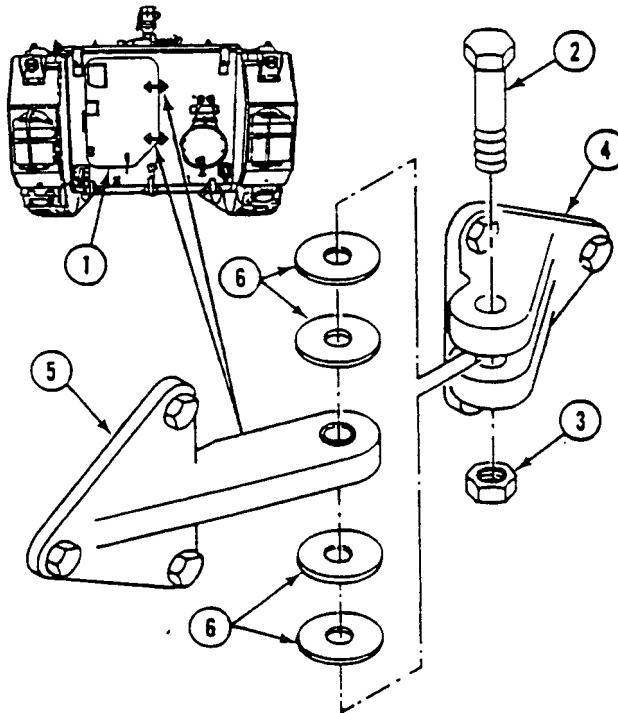

NOTE

Shims may not be installed on some vehicles.

4. Remove six screws (1), two hinges (2), and shims (3) from ramp (4). Discard shims.
5. Remove six screws (5), two hinges (6), and shims (7) from ramp door (8). Discard shims.

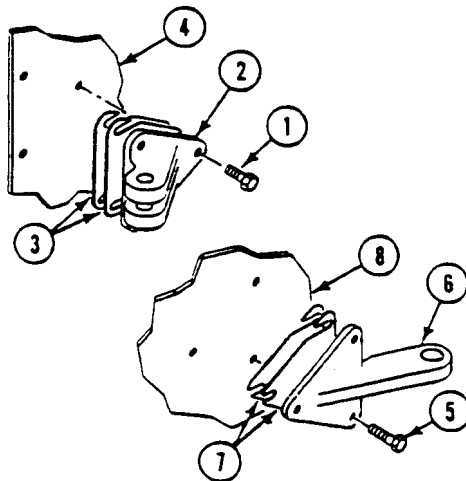

INSTALLATION

NOTE

Shims are used as required for alignment and sealing of ramp door.

1. Install two new shims (7), two hinges (6), and six screws (5) on ramp door (8). TIGHTEN SIX SCREWS TO 151-166 FT-LB (205-225 N·m) TORQUE.
2. Install two new shims (3), two hinges (2), and six screws (1) on ramp (4). TIGHTEN SIX SCREWS TO 151-166 FT-LB (205-225 N·m) TORQUE.

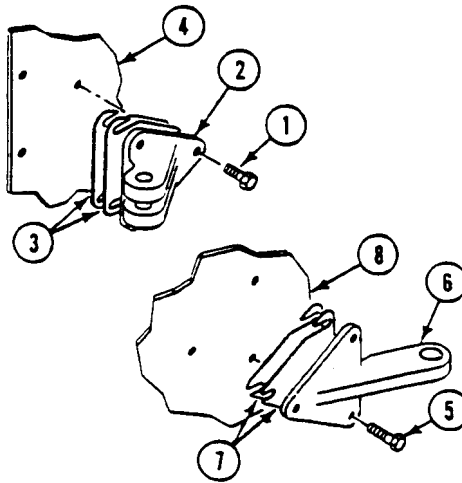

3. Attach ramp door (8) to a suitable lifting device.

NOTE

Edge of door must be flush with ramp weldment within $\pm 1/8$ inch (3 mm) around perimeter except where noted.

4. Position ramp door (8) on ramp (4).

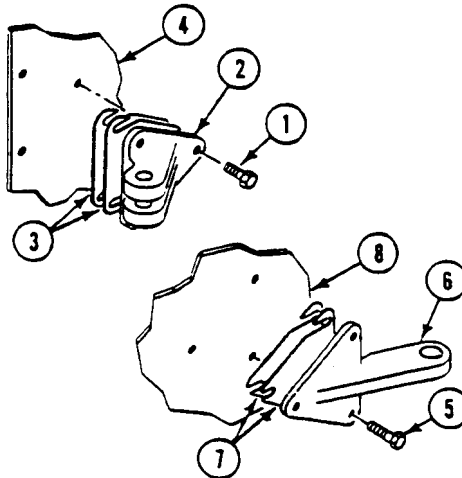

NOTE

Proper alignment and sealing of ramp door is accomplished by installing washer(s) between door hinges and ramp hinges to keep outer edges of door flush with ramp weldment within $\pm 1/16$ inch (1.5 mm).

5. Install washers (9) between door hinges (6) and ramp hinges (2).
6. Install two screws (10) and new locknuts (11) on hinges (2)(6).

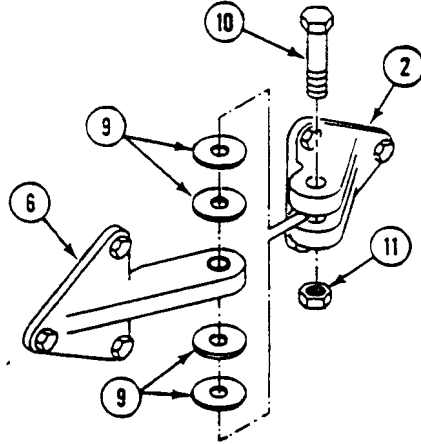

7. Check ramp door seal in the same manner as ramp seal. Chalk pattern should be evenly distributed over interior sealing lip of ramp door. If pattern is uneven, adjust door handle (see your -20).

END OF TASK

REPLACE RAMP ACCESS DOOR HINGE BEARINGS (M113A3 ONLY)

0058 00

THIS WORK PACKAGE COVERS:

Removal (page 0058 00-1).
 Installation (page 0058 00-1).

INITIAL SETUP:

Maintenance Level

Direct Support

References

See your -10

Tools and Special Tools

General Mechanic's Tool Kit (WP 0120 00, Item 62)
 Arbor Press (WP 0120 00, Item 43)

Equipment Condition

Engine stopped (see your -10)
 Ramp raised and locked (see your -10)
 Carrier blocked (see your -10)
 Ramp access door and hinges removed (WP 0057 00)

Materials/Parts

Bearing (2)

Personnel Required

Track Vehicle Repairer 63H10

REMOVAL

1. Remove bearings (1). Use arbor press.

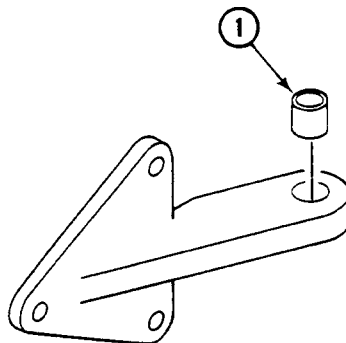

INSTALLATION

1. Install bearings (1). Use arbor press.

FOLLOW-THROUGH STEPS

1. Install ramp access door and hinges (WP 0057 00).

END OF TASK

REPAIR RAMP ACCESS DOOR (ALL EXCEPT M113A3)

0059 00

THIS WORK PACKAGE COVERS:

Removal (page 0059 00-1).
 Installation (page 0059 00-2).

INITIAL SETUP:

Maintenance Level

Direct Support

Tools and Special Tools

General Mechanic's Tool Kit (WP 0120 00, Item 62)
 Lifting device with rated lift capability of at least 200 lbs
 (91 kg)

Personnel Required

Track Vehicle Repairer 63H10
 Helper (H)

References

See your -10
 See your -20

Equipment Condition

Ramp raised and locked (see your -10)
 Engine stopped/shutdown (see your -10)
 Carrier blocked (see your -10)

REMOVAL

WARNING

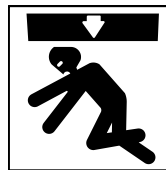

Door could fall and injure you. Make sure door is held by a lifting device before removing hinge screws.

1. Attach door to lifting device.
2. Remove two nuts (1), screws (2), and spacers (3) that secure ramp door (4) to four hinge parts (5) on ramp (6). Remove door from ramp. Have helper assist.
3. Remove two shoulder bushings (7) from two hinges (8) on ramp door (4).

4. Remove two bushings (9) from two upper hinge parts (5) on ramp (6). Remove two shoulder bushings (10) from two lower hinge parts (5).

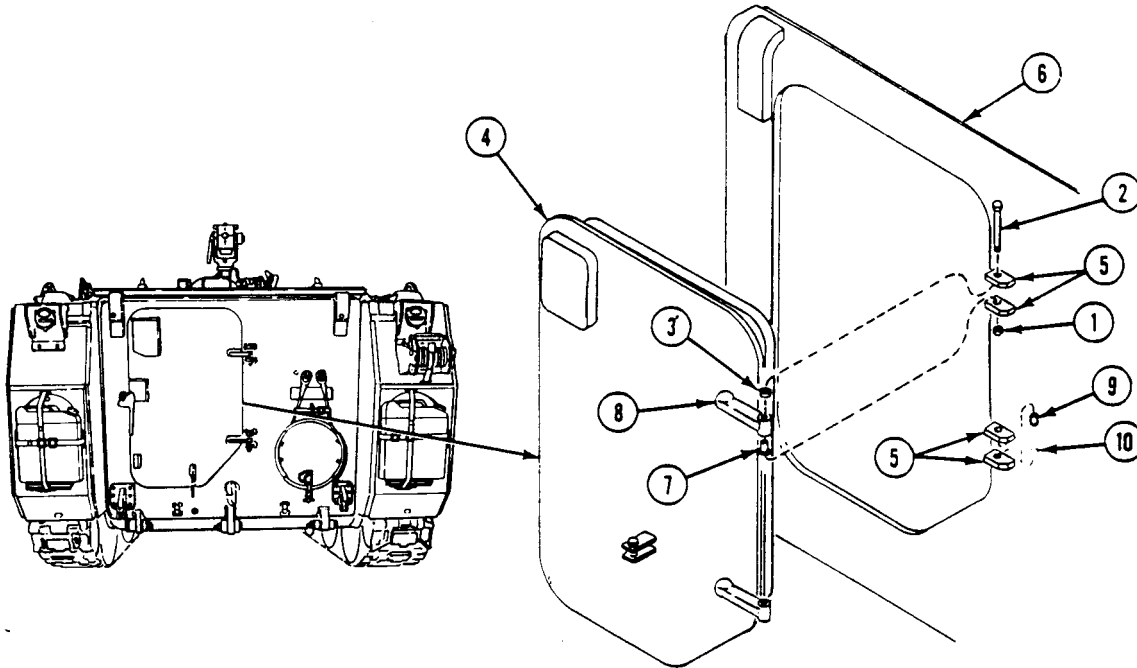

INSTALLATION

NOTE

Shoulder bushings provide clearance between spacer and upper ramp hinge part. Replace bushings that do not provide 1/16 inch (2 mm) clearance.

1. Install two shoulder bushings (1) in two lower hinge parts (2) on ramp (3).
2. Install two bushings (4) in two upper hinge parts (2) on ramp (3).
3. Install two shoulder bushings (5) in two hinges (6) on ramp door (7).

- Place door (7) in ramp (3). Secure with two spacers (8), screws (9), and nuts (10).

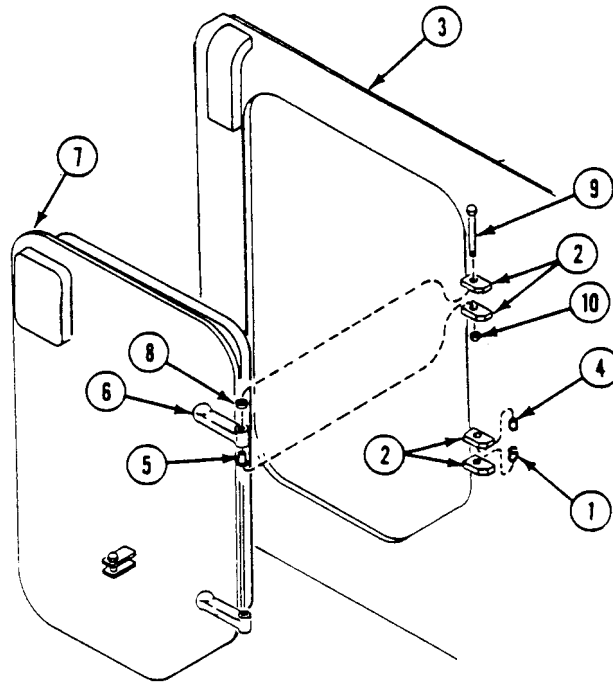
**FOLLOW-THROUGH STEPS**

- Adjust handle (see your -20).

END OF TASK

REPAIR DRIVER'S HATCH COVER HINGES

0060 00

THIS WORK PACKAGE COVERS:

Removal (page 0060 00-2).
Installation (page 0060 00-3).

INITIAL SETUP:

Maintenance Level

Direct Support

Tools and Special Tools

Metal Worker's Tool Kit (WP 0120 00, Item 63)
Trailer Mounted Welding Shop (WP 0120 00, Item 69)
Sander Spindle Adapter (WP 0120 00, Item 1)
Welder's Gloves (WP 0120 00, Item 18)
Industrial Goggles (WP 0120 00, Item 19)
Welder's Helmet (WP 0120 00, Item 21)
Electric Disc Sander (WP 0120 00, Item 46)
Arc Welding Machine (WP 0120 00, Item 68)

Materials/Parts

Enamel (WP 0122 00, Item 12)
Welding electrode (WP 0122 00, Item 35)

Personnel Required

Metal Worker 44B10

References

See your -20
TM 43-0139
TM 9-237
Welding Code 12472301

Equipment Condition

Driver's hatch cover removed (see your -20)

REMOVAL

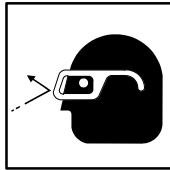
WARNING

Metal chips and grinding dust can cause eye injury. Wear goggles and gloves.

1. Remove and discard broken hinge part (1), (2), or (3) from hatch cover (4).
2. Use a machinist hammer and a cold chisel to chip off remaining part of bad hinge (1), (2), or (3) from hatch cover (4).
3. Use a disc sander to sand chipped area smooth and remove any hard coating from weld area.

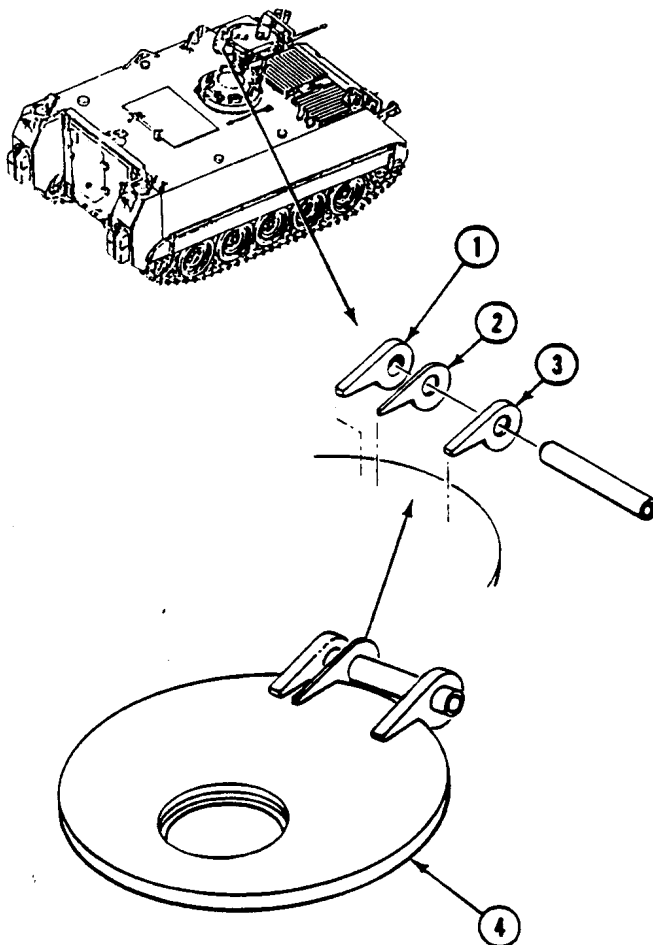

INSTALLATION

1. Clamp or tack weld new hinge (1), (2), or (3) on hatch cover (4). Check alignment of cover hinges with hinges on hull.
2. Insert spring shield (5) through hinges (3) or (2). Seat shield in hinge (1).
3. Make sure hinges are aligned and spaced as shown.
4. Weld hinge (1), (2), or (3) to hatch cover (4). See TM 9-237. Use electrode type 5356.
5. Clean the weld area and apply touch-up paint to repaired area. See TM 43-0139.

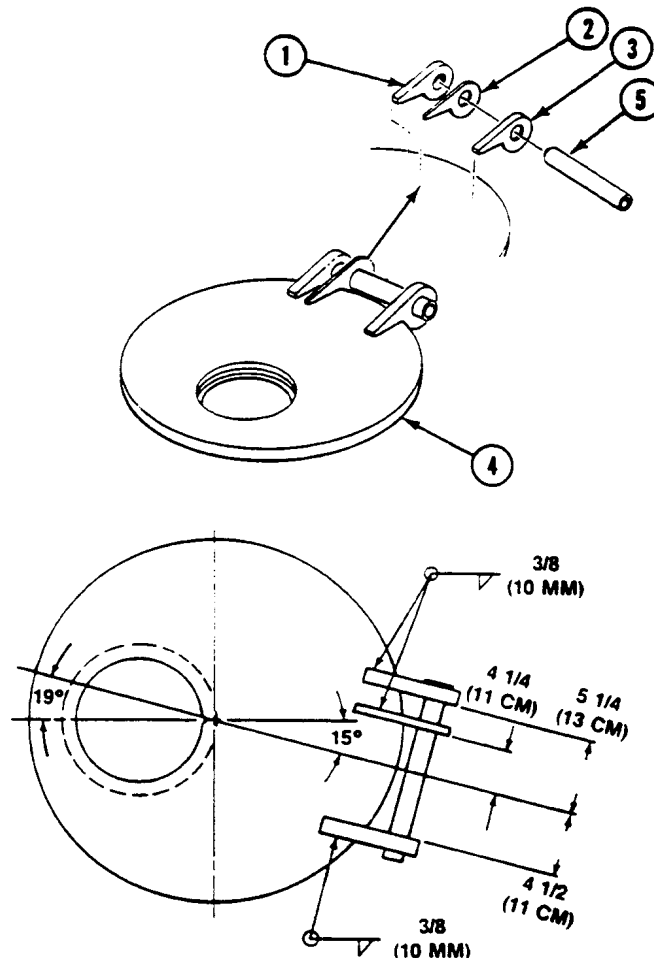

FOLLOW-THROUGH STEPS

1. Install driver's hatch cover (see your -20).

END OF TASK

REPAIR DRIVER'S HATCH COVER HULL HINGES

0061 00

THIS WORK PACKAGE COVERS:

Removal (page 0061 00-1).
 Installation (page 0061 00-3).

INITIAL SETUP:

Maintenance Level

Direct Support

Materials/Parts

Enamel (WP 0122 00, Item 12)
 Welding electrode (WP 0122 00, Item 35)

Tools and Special Tools

Metal Worker's Tool Kit (WP 0120 00, Item 63)
 Trailer Mounted Welding Shop (WP 0120 00, Item 69)
 Sander Spindle Adapter (WP 0120 00, Item 1)
 Welder's Gloves (WP 0120 00, Item 18)
 Industrial Goggles (WP 0120 00, Item 19)
 Welder's Helmet (WP 0120 00, Item 21)
 Electric Disc Sander (WP 0120 00, Item 46)
 Arc Welding Machine (WP 0120 00, Item 68)

Personnel Required

Metal Worker 44B10

References

See your -20
 TM 43-0139
 TM 9-237

Equipment Condition

Driver's hatch cover removed (see your -20)

REMOVAL

WARNING

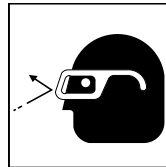

Metal chips and grinding dust can cause eye injury. Wear goggles and gloves.

1. Remove and discard broken hinge part (1) or (2) from hatch mounting ring (3) on hull.
2. Use a machinist hammer and a cold chisel to chip off remaining part of bad hinge (1) or (2) from hatch mounting ring (3) on hull.

3. Use a disc sander to sand chipped area smooth and remove any hard coating from weld area.

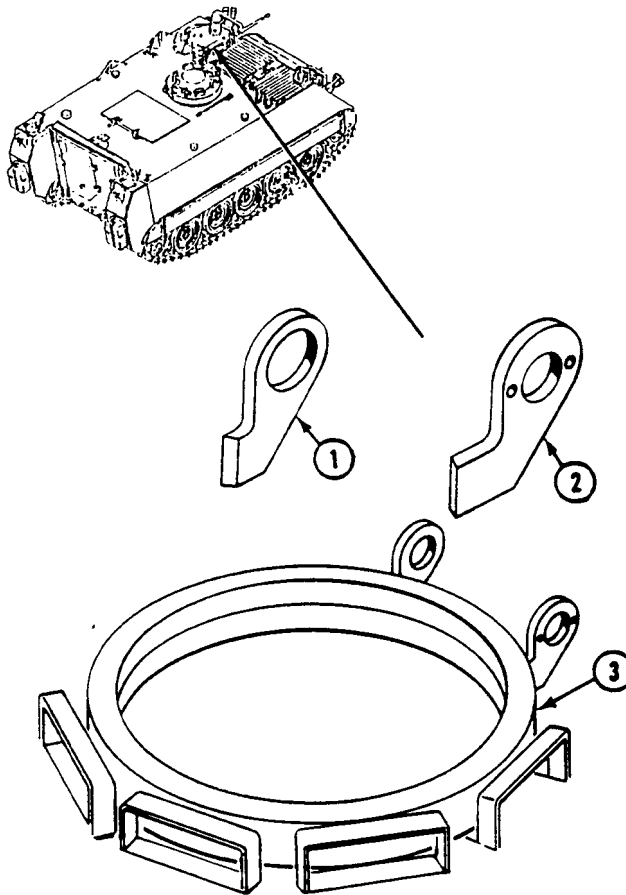

INSTALLATION

1. Clamp or tack weld new hinge (1) or (2) on mounting ring (3). Set cover on mounting ring. Check alignment of cover hinges with hinges of ring (3).
2. Insert spring shield (4) through hinges (1)(2) and cover hinges (5)(6)(7). Seat shield in cover hinge (7).
3. Make sure hinges (1) or (2) are aligned and spaced as shown.
4. Weld hinge (1) or (2) to mounting ring (3) and hull. See TM 9-237. Use electrode type 5356.
5. Clean the weld area and apply touch-up paint to repaired area. See TM 43-0139.

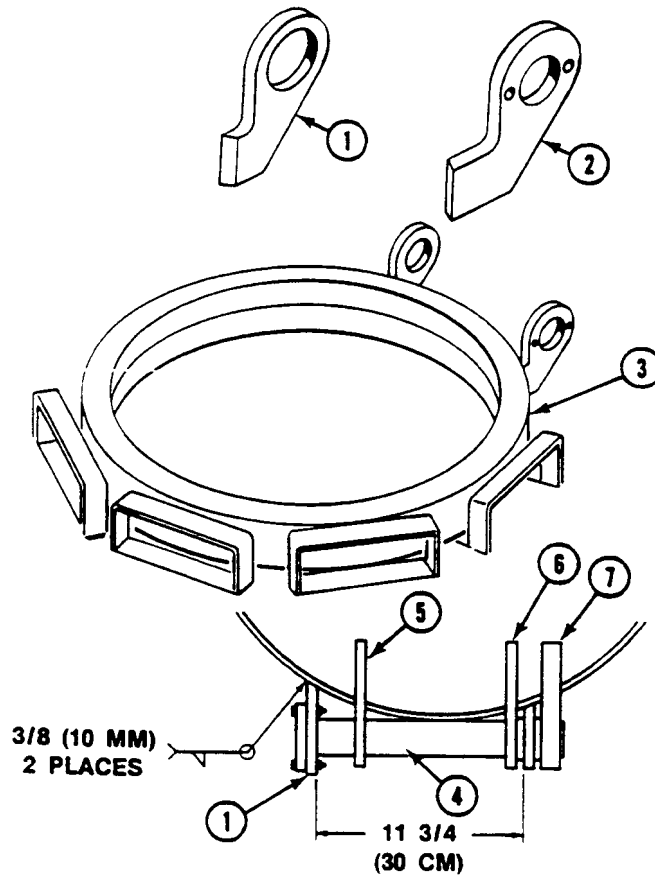
**FOLLOW-THROUGH STEPS**

1. Install driver's hatch cover (see your -20).

END OF TASK

CHAPTER 12

DIRECT SUPPORT MAINTENANCE INSTRUCTIONS
FOR HULL ACCESSORY ITEMS

WORK PACKAGE INDEX

<u>Title</u>	<u>Sequence No.</u>
REPAIR TENT (M577A3 ONLY).....	0062 00
REPAIR TENT (M1068A3 ONLY).....	0063 00
DELETED.....	0064 00

REPAIR TENT (M577A3 ONLY)

0062 00

THIS WORK PACKAGE COVERS:

- Inspection of Installed Items (page 0062 00-1).
 - Repair or Replacement (page 0062 00-2).
-

INITIAL SETUP:

Maintenance Level

Direct Support

Personnel Required

Fabric Repairman 43M20

Tools and Special Tools

- General Mechanic's Tool Kit (WP 0120 00, Item 62)
- Industrial Sewing Machine (WP 0120 00, Item 51)

References

- See your -10
- FM 10-16

Materials/Parts

- Adhesive sealant (WP 0122 00, Item 3)
 - Canvas preservative coating (WP 0122 00, Item 7)
 - Cotton duck cloth (WP 0122 00, Item 10)
 - Cleaning compound (WP 0122 00, Item 8)
 - Polyester thread (WP 0122 00, Item 22)
-

INSPECTION OF INSTALLED ITEMS

1. Check tent. Mark defects to be repaired.

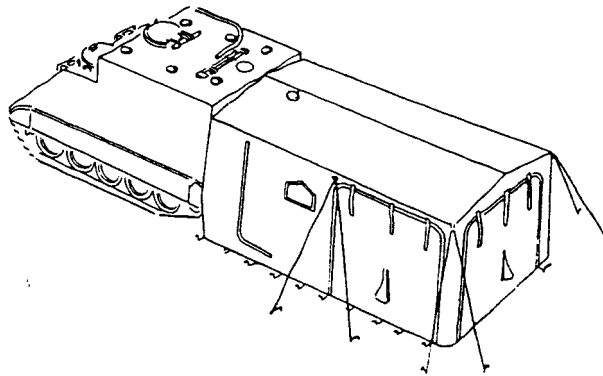

2. Check framework, support leg, ridge, eave and bow poles, joints, adjusting pins and chains. Remove burs. Straighten bends and dents. Weld broken joints. Replace badly damaged parts.
3. Check tensile strength of fabric. Grasp a small fold of fabric between thumb and forefinger of each hand, gripping it closely so tips of forefingers touch. Test material against threads that run the length of material. The weaker cross threads should not be used for testing tensile strength. Tug material several times. If it does not rip, it is repairable. If it tears on first tug, test several areas for extent of damage. Weak sections must be replaced.
4. Check fabric. Repair sections that have been weakened by stains or that cannot be brushed clean. Repair or replace sections that are worn or torn or have a large number of patches.
5. Check stitching. Repair runoffs and broken threads. Restitch weak stitching and open seams.
6. Check webbing. Repair or replace tie tapes, guy lines, corner straps and web reinforcements that are frayed, worn or torn.
7. Check leather. Replace leather reinforcements that are cracked, worn or weak.
8. Check hardware. Replace parts that are broken, bent, corroded or missing.

9. Check toggles. Replace split, broken or missing toggles.
10. Check loops, guy lines, foot stops and mounting lines. Replace parts that have frayed or broken strands or raveled ends.
11. Check netting. Replace torn netting.

REPAIR OR REPLACEMENT**NOTE**

To repair fabric, use 12-19/64 ounce (363 ml) per square cotton sateen or cotton duck and size FF polyester thread. The cloth and thread must be fire, water, weather and mildew resistant.

1. Use lockstitching to install all patches, straps, flaps and side fasteners and to repair open seams. Use smallest needle size you can to make weatherproof seams. Allow 5 to 7 stitches per 1 inch (3 cm). Backstitch all thread breaks at least 1 inch (3 cm). Backstitch all ends at least 1 inch (3 cm), except where ends are turned under in a hem or seam or held down by other stitching. Maintain thread tension so stitching is tight and lock is firmly fixed in center of material. Trim all ends.

Take care, when restitching, to make a new stitch line. All hardware, leather, webbing, lines and netting used for repair must be the same as the original material.

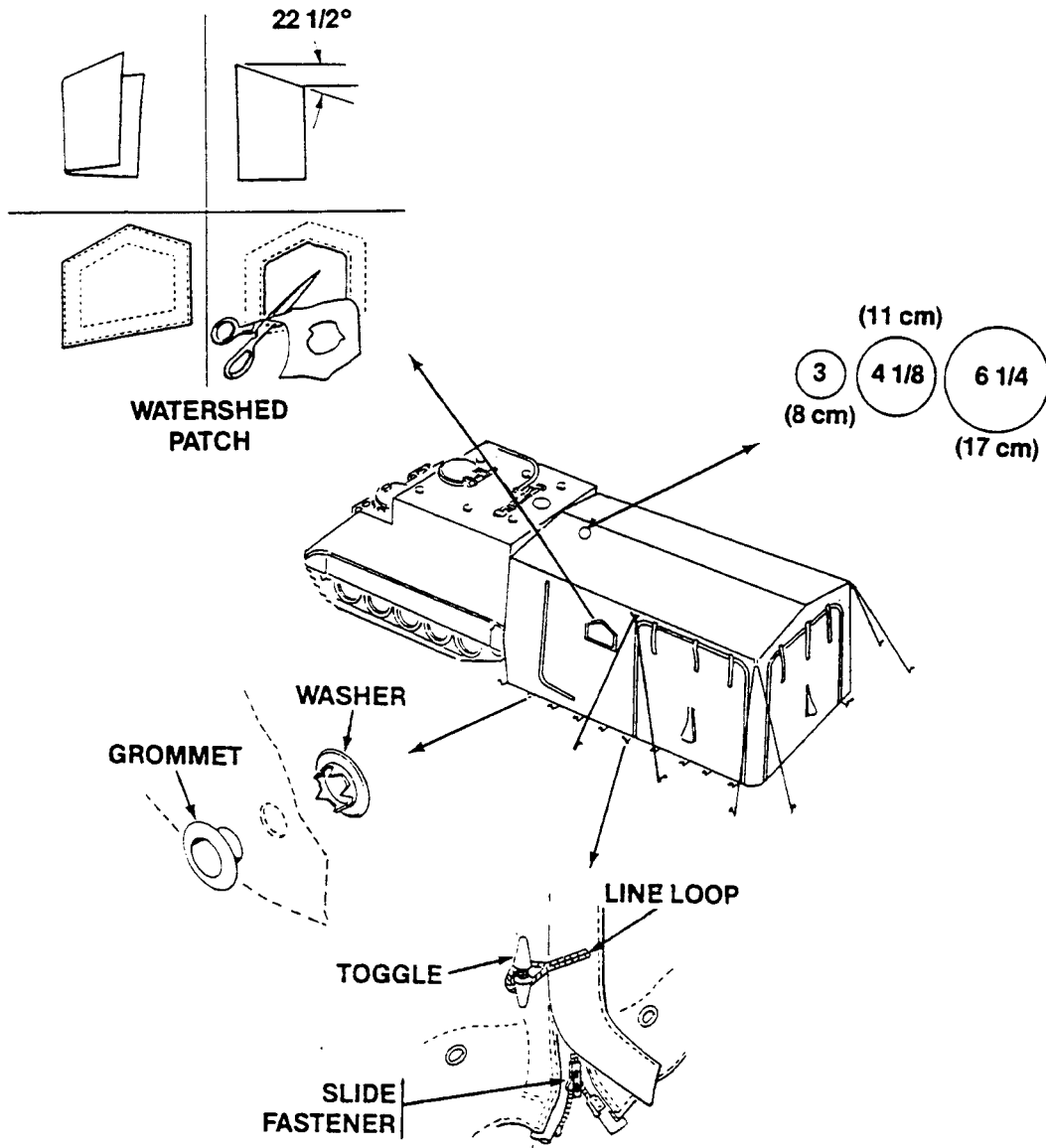

NOTE

A hole or tear in the tent more than 4-3/4 inches (12 cm) in diameter or length may be repaired by a cement patch. The tear must not occur on seams, edges, or areas that support hardware. The materials used to make a cement patch are adhesive, round patches, roller, board, wire brush, and soft bristled brush. For cement patch repair, do Steps 2 - 9.

2. Select one of three sizes of patches that will overlap damaged area with a margin of at least 3/4 inch (19 cm) on all sides.

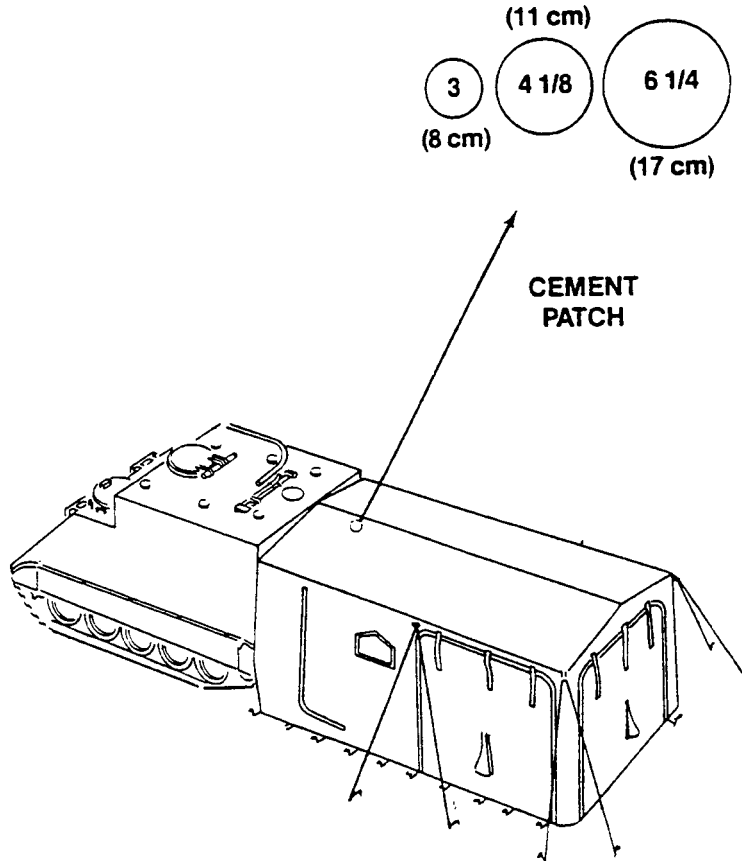

3. Place board under damaged area for a flat working surface.
4. Buff patch and damaged area of tent with a wire brush.

WARNING

Adhesive is flammable and can injure you. Keep it away from heat, sparks, and open flames. Avoid repeated or prolonged breathing of vapors. Avoid contact with your skin.

5. Center patch over damaged area. Apply adhesive to patch and patch edge with a soft bristle brush, making a circle on tent.

6. Lift patch. Apply adhesive to area of tent inside adhesive circle.
7. Allow adhesive to dry until tacky.
8. Press cement surfaces together firmly with roller while tacky.
9. Seal by wiping edge of patch with soft bristle brush.

NOTE

The watershed patch has the top edge angled to give a roof effect. Because the roof-type top edge sheds water, the patch lasts longer than a rectangular patch. For watershed patch repair, do Steps 10 - 14.

10. Cut patch large enough to overlap 2 inches (5 cm) on all sides of area to be repaired. Allow for 3/4 inch (19 mm) turn-under of edge.

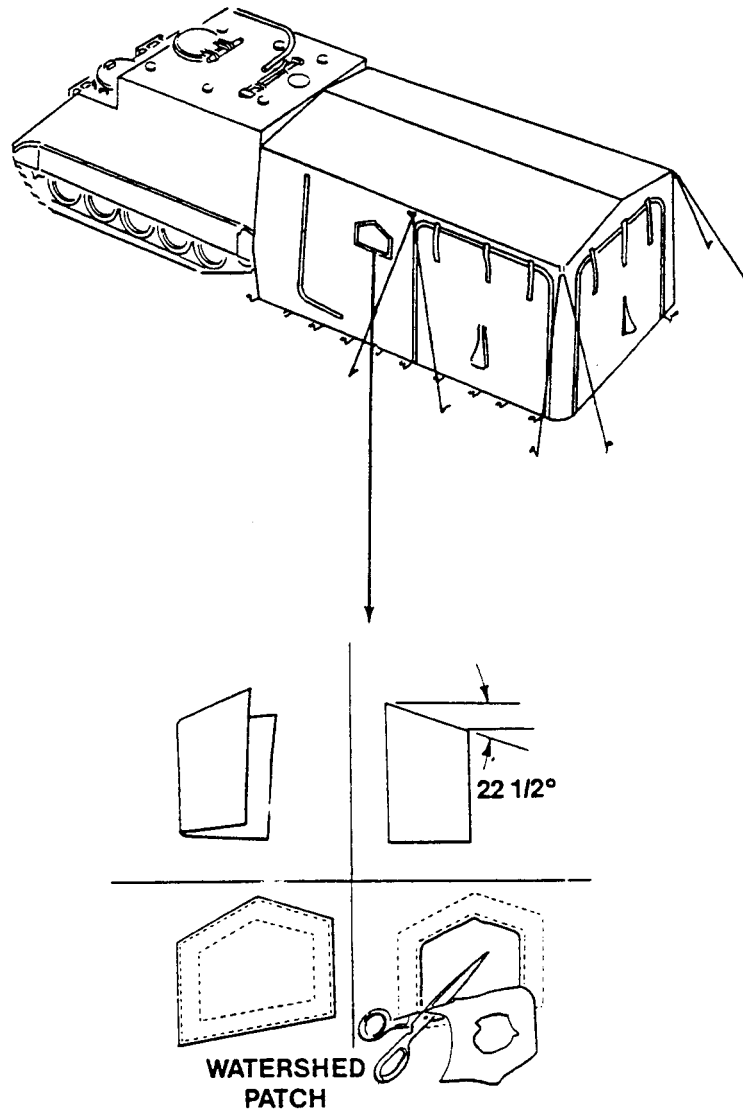

11. Fold patch in half lengthwise. Cut from open edges to folded edge at 22-1/2 degree angle.

12. Center patch over damaged area on outside of tent. Turn under patch edges. Stitch in place with a row of stitching no more than 1/8 inch (3 mm) from the edge.
13. Secure patch to tent with a second row of stitching. Place second row 3/8-1/2 inch (10-13 mm) from first row.
14. Turn material over. Cut away damaged area, notch corners, and turn edges in. Stitch turned edges to patch with a row of stitching no more than 1/8 inch (3 mm) from the edge.

NOTE

Extensive damage between seams is repaired with a seam-to-seam patch. For seam-to-seam patch repair, do Steps 15 - 19.

15. Open seam 2 inches (5 cm) beyond damaged area on both sides.
16. Square off damaged area from seam to seam.
17. Cut patch 2 inches (5 cm) wider than squared-off section. Allow for 3/4 inch (19 mm) turn-under on sides.
18. Center patch over cutaway section. Turn sides under and reform double-felled seams at top and bottom.
19. Finish by stitching patch into place.

NOTE

For webbing and reinforcement repair, do Step 20 and Step 21.

20. Install webbing and reinforcements. Machine stitch a rectangular pattern 1/8 inch (3 mm) in from the edges, a set of stitches 1/8 inch (3 mm) in from end stitchings, and diagonal stitches from corner to corner.

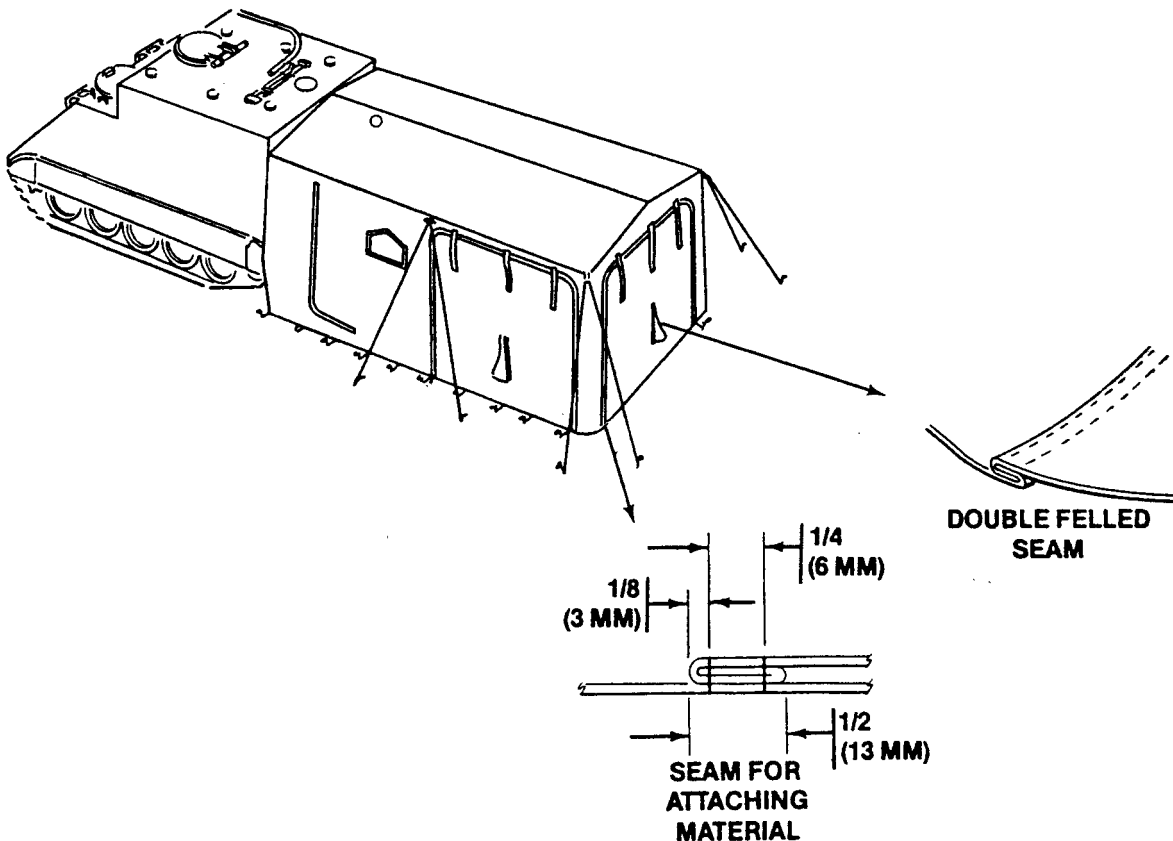

21. Attach all leather reinforcements. Use the same stitching method used for webbing.
22. Install end clips. Insert strap into ball-type end clip. Flatten clip with hammer.
23. Install grommets per FM 10-16. Holes punched in the material to receive grommets shall be smaller than outside diameter of grommet barrel. Clinch grommets firmly without cutting material.

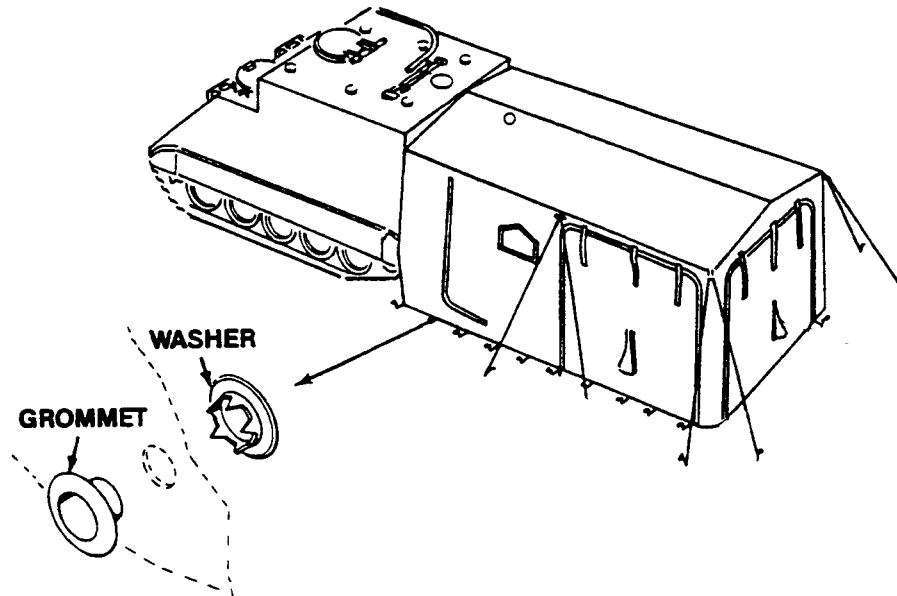

24. Install line loops in fastener flaps. Use hand-sewn, overcast stitch. See FM 10-16 for overcast stitch and information on hand sewing.

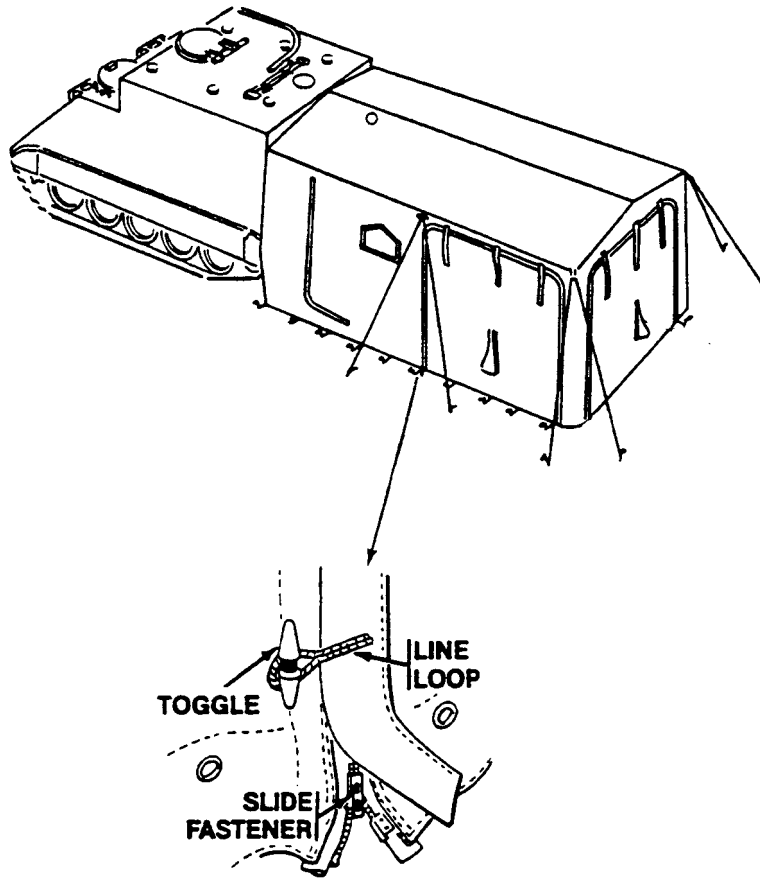

25. Install netting. Use machine stitching.

NOTE

The tent should be treated, as needed. Use sealing compound that is textile, paste form and fire, water, weather and mildew resistant. To use sealing compound, do Steps 26 - 31.

WARNING



Sealing compound is flammable. Keep it away from open flame. Keep compound off your skin. Wash well after handling. Use solvent spray precautions.

26. Make sure tent is dry. Remove dirt, oil and grease stains.
 27. Erect tent (see your -10).

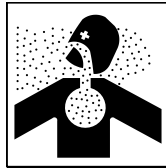
WARNING

Solvent fumes and fluid are poisonous and can cause skin irritation.

Solvent may be harmful if swallowed. Avoid skin contact and breathing of fumes. Read solvent warning at the front of this manual.

WARNING

Solvent evaporates rapidly and makes fumes that are flammable.

Do not smoke or allow open flames near solvent fumes.

Read solvent warning at the front of this manual.

28. Reduce paste to spray consistency by mixing with cleaning compound.
29. Apply compound by spray gun. Operator should wear respirator.
30. Apply compound to patches and newly repaired areas.
31. Allow at least 24 hours for tent to dry.

FOLLOW-THROUGH STEPS

1. Stow or install tent on carrier (see your -10).

END OF TASK

REPAIR TENT (M1068A3 ONLY)

0063 00

THIS WORK PACKAGE COVERS:

Repair or Replacement (page 0063 00-1).

INITIAL SETUP:

Maintenance Level

Direct Support

References

TM 10-5410-229-13&P

Personnel Required

Fabric Repairman 43M20

REPAIR OR REPLACEMENT

1. To repair tent, see TM 10-5410-229-13&P.

END OF TASK

CHAPTER 13

DIRECT SUPPORT MAINTENANCE INSTRUCTIONS
FOR HYDRAULIC SYSTEM

WORK PACKAGE INDEX

<u>Title</u>	<u>Sequence No.</u>
REPLACE RAMP HYDRAULIC CYLINDER ANCHOR (M1064A3 ONLY).....	0065 00

REPLACE RAMP HYDRAULIC CYLINDER ANCHOR (M1064A3 ONLY)

0065 00

THIS WORK PACKAGE COVERS:

- Remove (page 0065 00-1).
- Modify (page 0065 00-2).
- Install (page 0065 00-5).

INITIAL SETUP:

Maintenance Level

Direct Support

Personnel Required

Track Vehicle Repairer 63H10

Tools and Special Tools

- General Mechanic's Tool Kit (WP 0120 00, Item 62)
- Portable Electric Drill (WP 0120 00, Item 7)
- Twist Drill Set (WP 0120 00, Item 9)
- Pneumatic Hammer (WP 0120 00, Item 20)
- Electrical Disc Sander (WP 0120 00, Item 46)
- Torque Wrench (WP 0120 00, Item 73)

References

- See your -10
- See your -20
- TM 9-1015-232-23&P
- TM 43-0139

Materials/Parts

- Adhesive primer (WP 0122 00, Item 23)
- Anchor
- Cotter pin
- Screw
- Washer
- Screw

Equipment Condition

- Engine stopped (see your -10)
- Carrier blocked (see your -10)
- Ramp lowered (see your -10)
- Mortar removed (see your -10)
- Mortar turntable and ring gear removed (TM 9-1015-232-23&P)

REPAIR OR REPLACEMENT

REMOVE

1. Remove cotter pin (1). Discard pin.

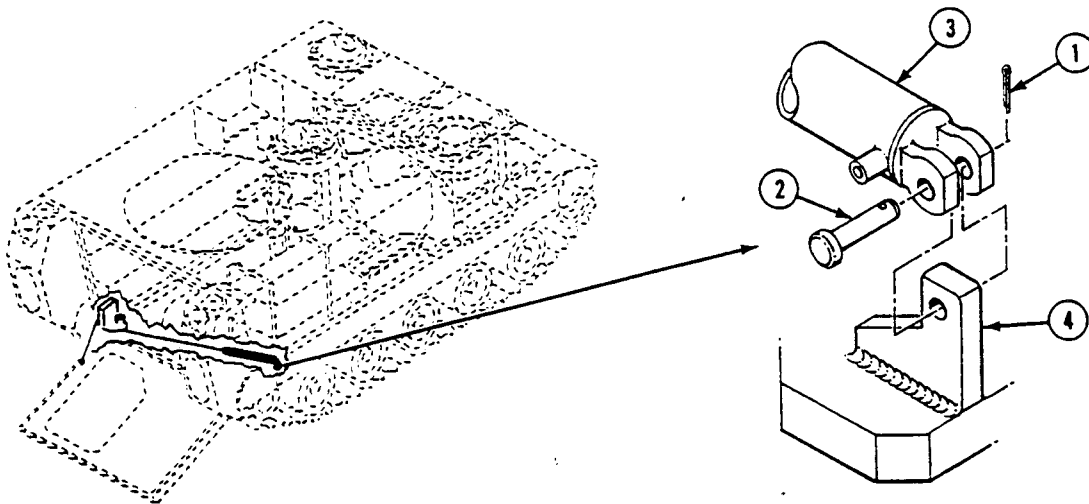

2. Remove headed pin (2). Retain pin.
3. Remove cylinder (3) from anchor (4).
4. Remove anchor (4) and all weld material from hull bottom plate. Discard anchor.

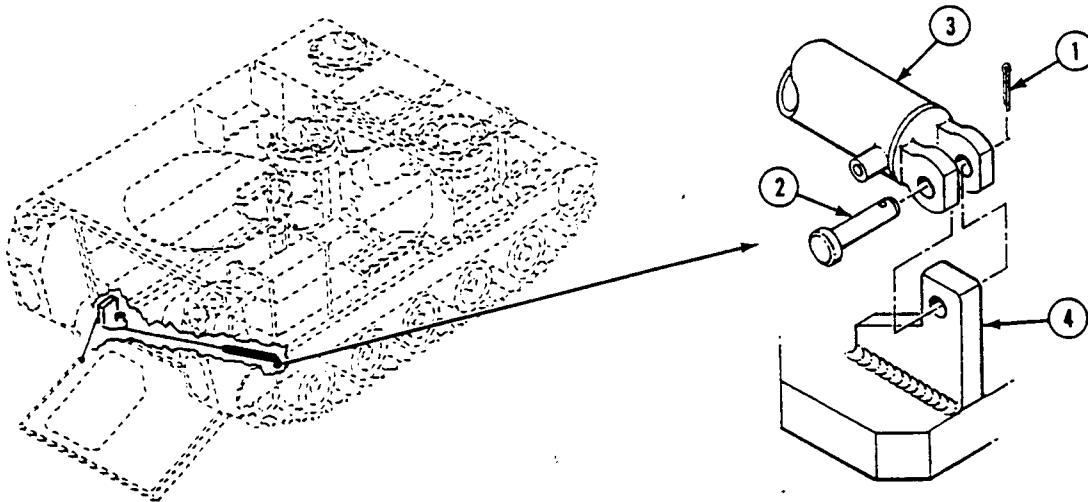
**MODIFY**

1. Grind weld area level and smooth.
2. Locate center of first hole as shown.

NOTE

Drill all holes straight and at right angles to hull bottom plate.

3. Drill first hole with 7/16 inch (11 mm) diameter drill. Bottom plate is 1-1/8 inches (3 cm) thick. Do not break through.
4. Tap first hole with a 1/2-13UNC tap to a minimum thread depth of 7/8 inch (22 mm).

REPLACE RAMP HYDRAULIC CYLINDER ANCHOR (M1064A3 ONLY) — Continued

0065 00

- Position new anchor (1) 32 degrees from reference line as shown, with centerline of anchor and bottom centerline of ramp pulley in alignment.

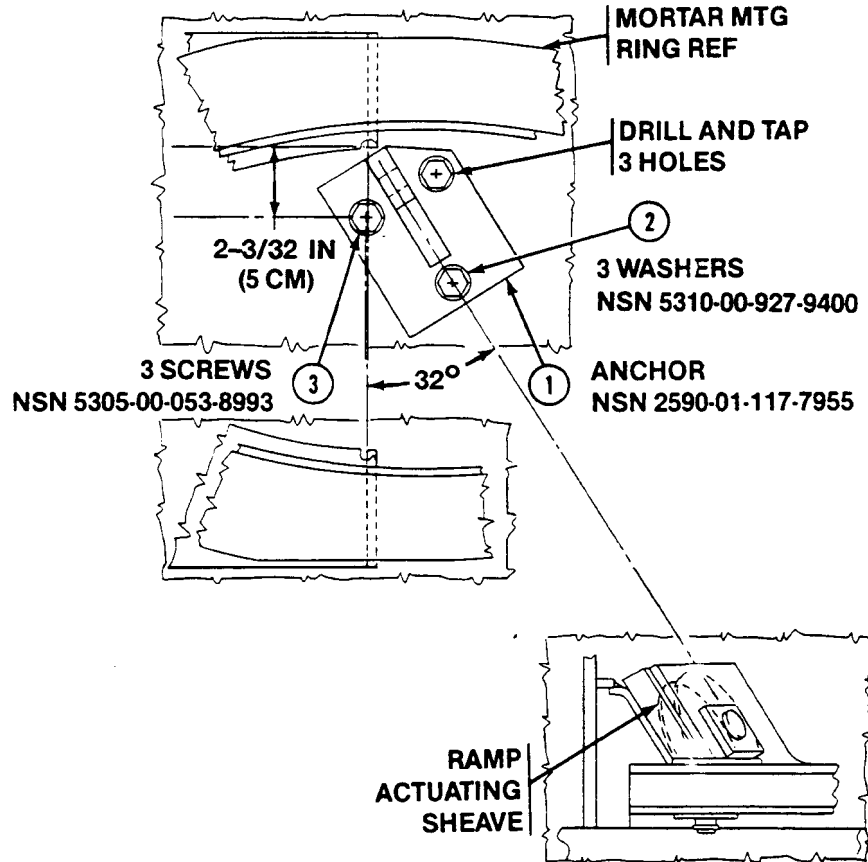

6. Secure anchor (1) with one new washer (2) and one new screw (3).
7. Use new anchor (1) as template. Locate center of remaining two holes. Remove anchor. Drill and tap holes same way as first hole Step 3 and Step 4.

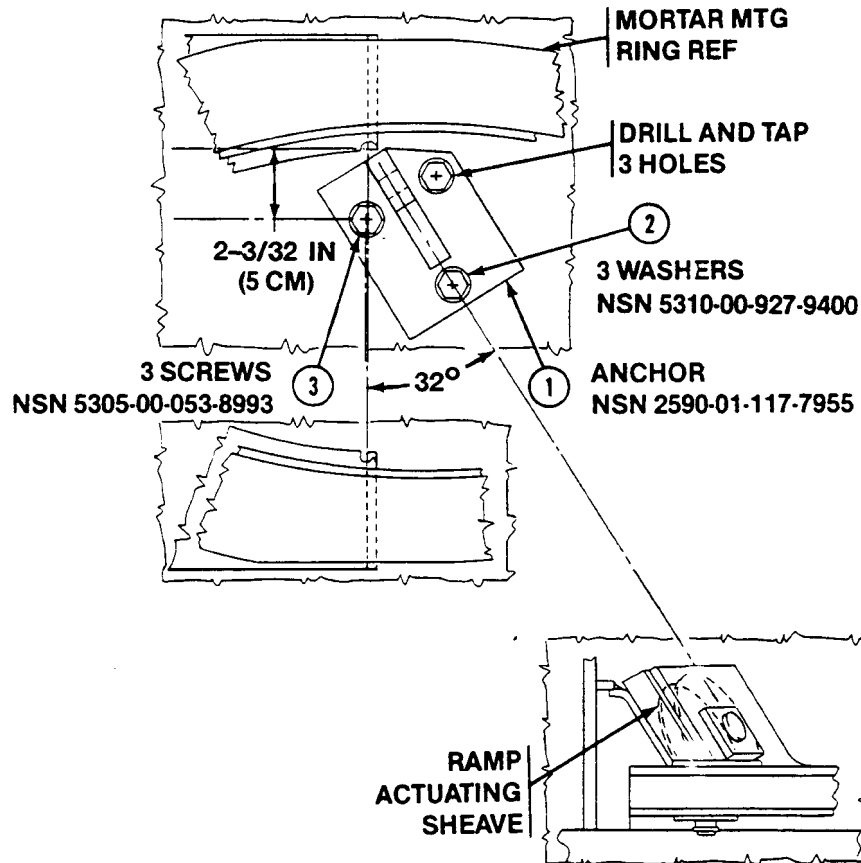

8. Clean surface with wire brush.
9. Paint any exposed metal surfaces. See TM 43-0139.

INSTALL

1. Install new anchor (1) with three new washers (2) and new screws (3).
2. **TIGHTEN SCREWS TO 54-59 LB-FT (73-80 N•m) TORQUE.** Use adhesive primer as lubricant on threads and under screw heads.
3. Install cylinder (4) on anchor (1) with headed pin (5). Secure with new cotter pin (6).

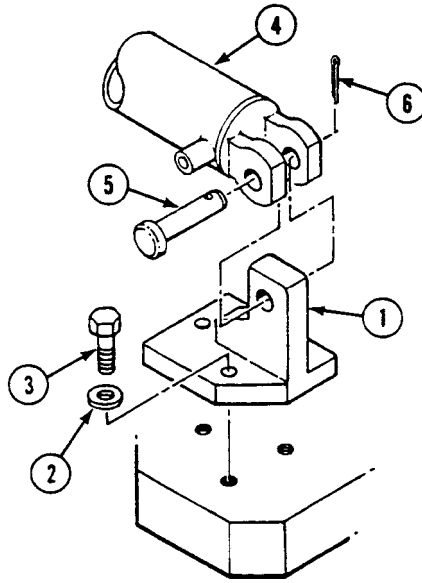
**FOLLOW-THROUGH STEPS**

1. Install mortar turntable and ring gear. See TM 9-1015-232-23&P.
2. Install mortar in carrier (see your -10).
3. Start engine (see your -10).
4. Raise and lock ramp (see your -10).
5. Stop engine (see your -10).

END OF TASK

CHAPTER 14

DIRECT SUPPORT MAINTENANCE INSTRUCTIONS
FOR TOOLS AND TEST EQUIPMENT

WORK PACKAGE INDEX

<u>Title</u>	<u>Sequence No.</u>
TEST LOAD POWER PLANT SLING.....	.0066 00
REPAIR POWER PLANT SLING.....	.0067 00
ADJUST ENGINE AND TRANSMISSION STAND.....	.0068 00
SERVICE ENGINE AND TRANSMISSION STAND.....	.0069 00
REPAIR ENGINE AND TRANSMISSION STAND.....	.0070 00

TEST LOAD POWER PLANT SLING

0066 00

THIS WORK PACKAGE COVERS:

Test and Inspection (page 0066 00-1).

INITIAL SETUP:

Maintenance Level

Direct Support

Personnel Required

Track Vehicle Repairer 63H10

Tools and Special Tools

General Mechanic's Tool Kit (WP 0120 00, Item 62)
Lifting device with rated lift capability of at least 6600
lb (2997 kg)

References

See TB 43-0142

Materials/Parts

Cotter pin
Suitable weight of 3000 lb (1362 kg)
Suitable weight (2 of 1500 lb (681 kg))

Equipment Condition

Power plant sling repaired and inspected (TB 43-0142)

TEST AND INSPECTION

NOTE

All fabricated weights and available items used for load testing must be verified for proper weight by use of a calibrated scale.

Cross beam legs should hold vertical loads and two legs at tip of beam should hold horizontal load at 60 degree angle.

1. Install main lifting shackle (1), screw (2), nut (3), and new cotter pin (4) in hole (5).

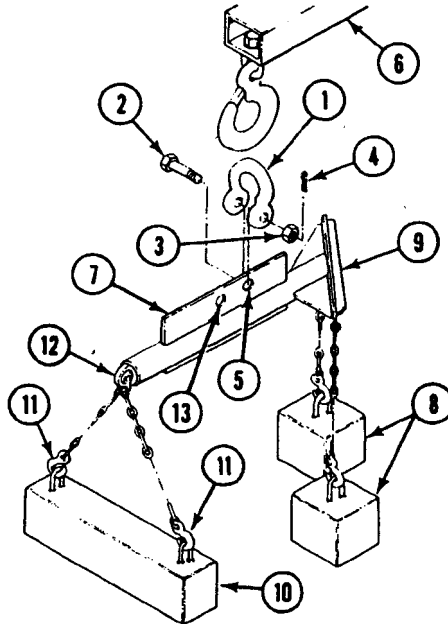

2. Attach lifting device (6) to shackle (1) and raise sling (7).

3. Attach 1,500 pound weights (8) to each cross beam leg (9) and attach 3,000 pound weight (10) to two legs (11) at tip of beam (12).

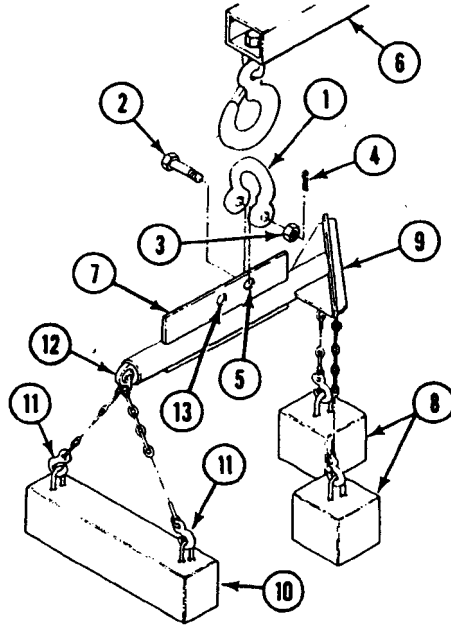

WARNING



Hanging loads could kill or injure you. Keep away from hanging loads and overhead equipment.

4. Raise sling (7) and weights (8) (10) until weights clear 6 to 12 inches from surface.
5. Allow sling (7) to support weights (8) (10) for a minimum of 10 minutes.

6. Inspect sling for distortion. See TB 43-0142.

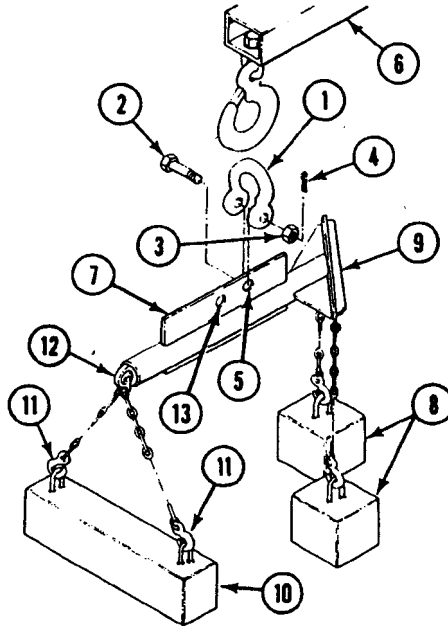

7. Lower sling (7) to relieve weights (8) (10). Repeat inspection of any areas of distortion found in Step 6. See TB 43-0142. No permanent distortion is allowed.
8. Remove cotter pin (4), nut (3), screw (2), and shackle (1) from hole (5). Discard cotter pin.
9. Repeat WP 0066 00, Step 1 for second hole (13).

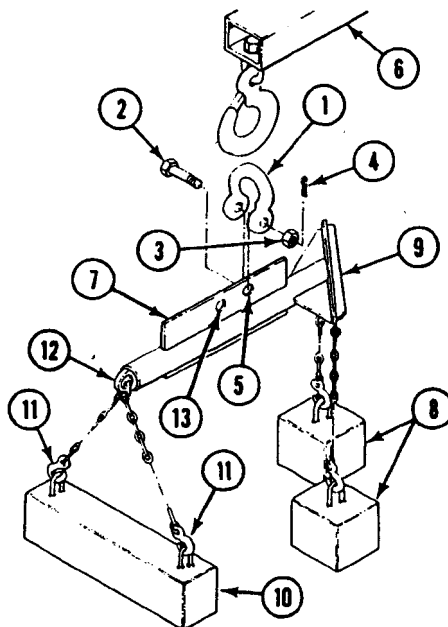

10. Repeat Steps 4 - 7.
11. Remove weights (8) (10) from sling (7).

12. Remove shackle (1) from lifting device (6).

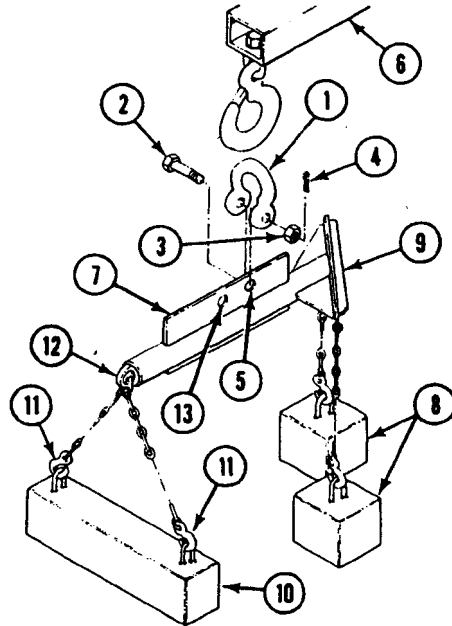

END OF TASK

REPAIR POWER PLANT SLING

0067 00

THIS WORK PACKAGE COVERS:

- Remove Leg Assembly (page 0067 00-1).
- Install Leg Assembly (page 0067 00-2).
- Repair Chain Links (page 0067 00-2).
- Repair Hooks (page 0067 00-3).
- Replace Data Plate (page 0067 00-4).
- Repair Beam Assembly (page 0067 00-4).

INITIAL SETUP:

Maintenance Level

Direct Support

Personnel Required

Track Vehicle Repairer 63H10
Metal Worker 44B10

Tools and Special Tools

Metal Worker's Tool Kit (WP 0120 00, Item 63)
Trailer Mounted Welding Shop (WP 0120 00, Item 69)

References

TM 9-237
TB 43-0142

Materials/Parts

Inspection penetrant (WP 0122 00, Item 17)
Sealing compound (WP 0122 00, Item 27)
Data plate
Drive screw (4)

Equipment Condition

Power plant sling inspected - periodic (TB 43-0142)

REPAIR OR REPLACEMENT

REMOVE LEG ASSEMBLY

1. Remove pin (1) from shackle (2).
2. Remove chain (3) from shackle (2).

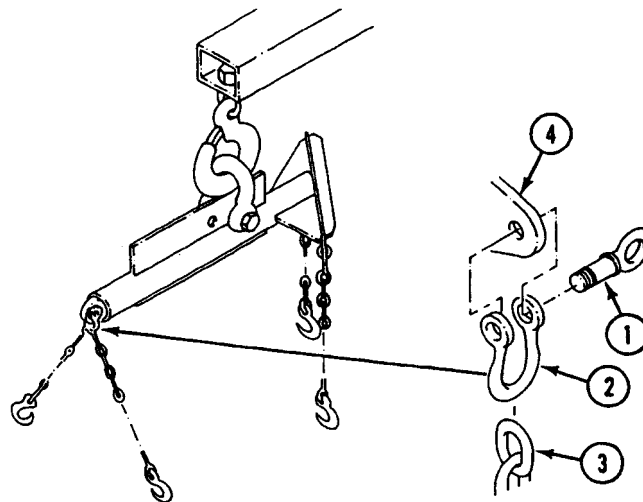

INSTALL LEG ASSEMBLY

1. Position chain (3) over shackle (2).
2. Add sealing compound to threads on pin (1).
3. Install pin (1) in shackle (2). Hook should point away from support beam (4).

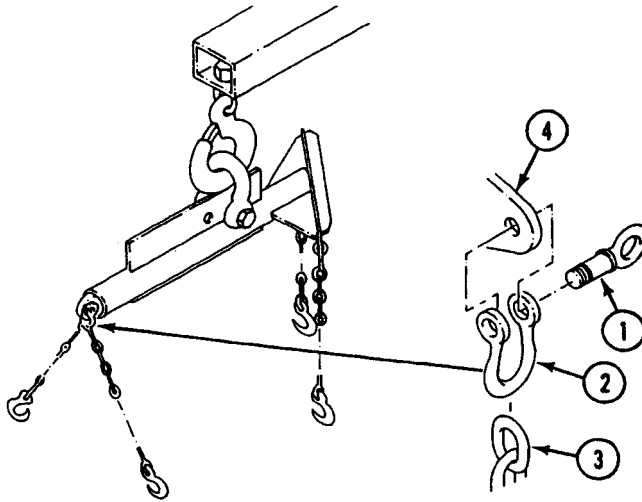

REPAIR CHAIN LINKS

1. Repair chain links (1) by draw filing to blend out nicks. Do not exceed wear limits for the size link used: 3/64 inch (.234 cm) diameter for 9/32 inch chain and 5/64 inch (.296 cm) diameter for 3/8 inch chain.

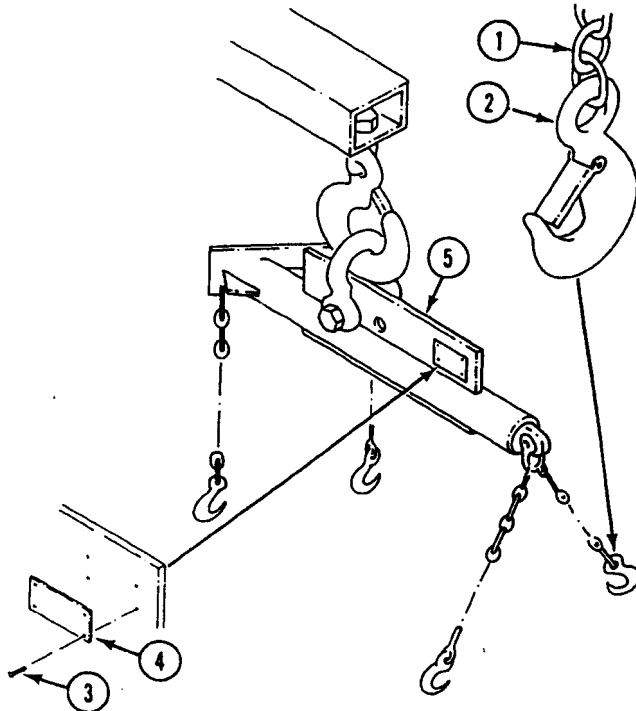

REPAIR HOOKS

1. Repair cracks, nicks, and gouges on hooks (2) by filing or grinding longitudinally, following contour of hook, provided no dimension is reduced more than 10% of its original value.

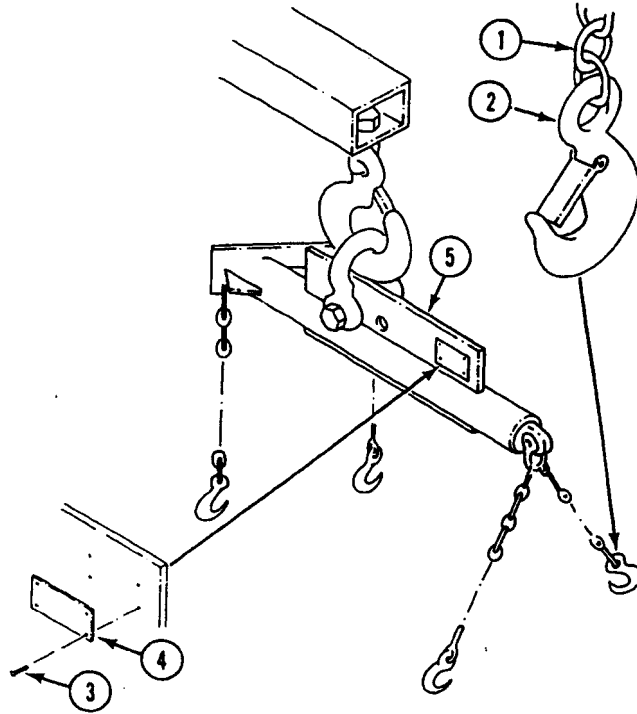

2. Perform die-penetrant inspection to ensure repair of cracks has been completed.

REPLACE DATA PLATE

1. Remove four drive screws (3) from data plate (4). Remove data plate. Discard plate and screws.

NOTE

To order a new data plate, provide Depot with the same information contained on the original data plate: Contract Number, Serial Number, Date of Manufacture, Maximum Work Load, Proof Load, National Stock Number, Part Number, and Commercial and Government Entity Code.

2. Locate new data plate (4) in same location. Use the data plate as a template to drill four mounting holes $3/64$ to $1/16$ inch diameter and $5/32$ inch deep minimum.
3. Install four new drive screws (3) on data plate (4).

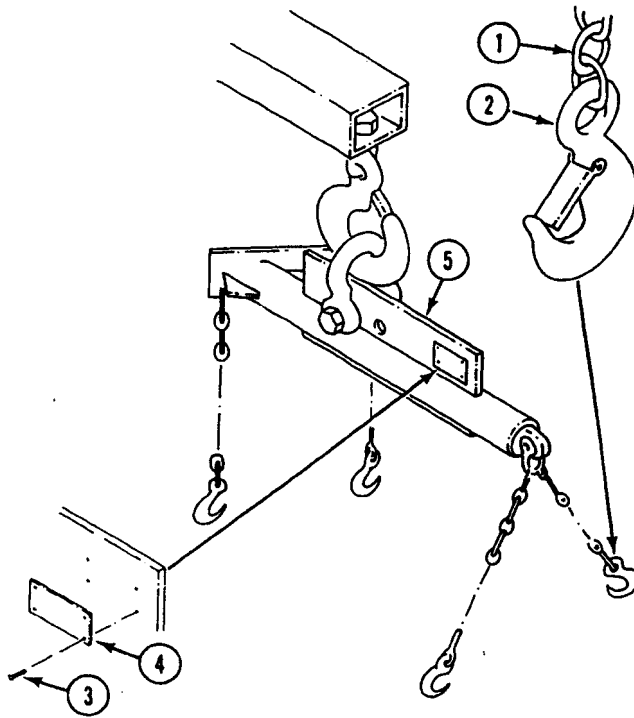
**REPAIR BEAM ASSEMBLY**

1. Repair cracked or torn welds by machining or grinding the defective beam assembly (5) to approximately 1.0 inch beyond the defect. Minimum root dimension should be $1/16$ inch radius. The base metal is aluminum, class 5083-H32. Use gas metal-arc welding process (GMAW) and ANSI/AWS A5.10, class 5356 electrode, weld size $1/4$ inch minimum IAW MIL-W-45305, class A.

2. Inspect beam assembly (5) for undercut, overlap, surface cavities, surface cracks in weld metal, or in heat-affected zone of base metal, and lack of weld penetration defects.

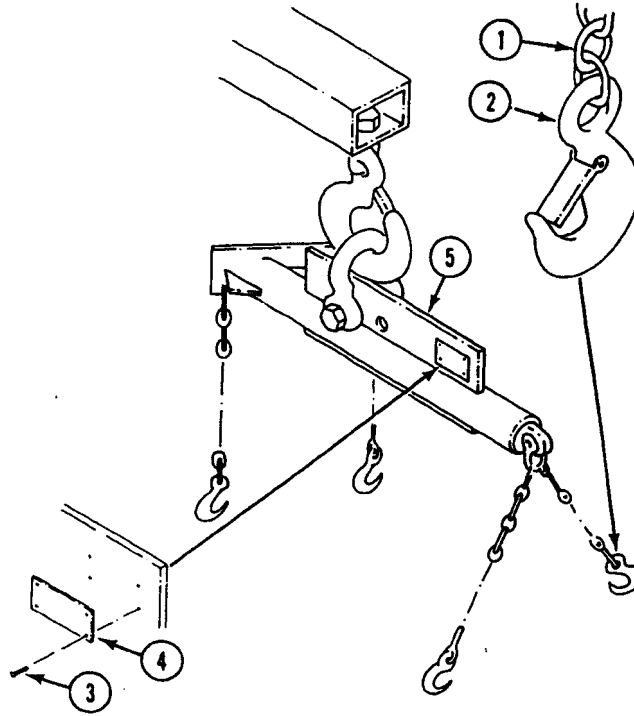
**FOLLOW-THROUGH STEPS**

1. Test load power plant sling (WP 0066 00).
2. Complete required forms.

END OF TASK

ADJUST ENGINE AND TRANSMISSION STAND

0068 00

THIS WORK PACKAGE COVERS:

Adjustment (page 0068 00-1).

INITIAL SETUP:

Maintenance Level

Direct Support

Personnel Required

Track Vehicle Repairer 63H10

Tools and Special Tools

- General Mechanic's Tool Kit (WP 0120 00, Item 62)
- Engine and Transmission Sling (WP 0120 00, Item 52)
- Lifting device with rated lift capability of at least 2,750 lb (1,249 kg)

References

See your -20

Equipment Condition

- Engine and transmission stand blocked
- Power plant removed from carrier (see your -20)

ADJUSTMENT

1. Turn the hand wheel (1) clockwise toward transmission support (2) until engine support wheels (3) are against the stops (4).

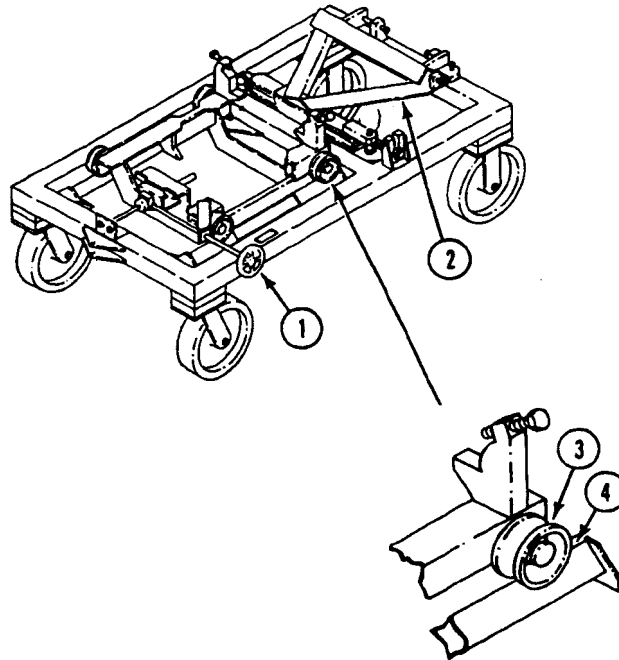

WARNING

Hanging loads could kill or injure you. Keep away from hanging loads and overhead equipment. Keep hands away from stand while engine is being lowered.

2. Slowly lower power plant (5) down on the engine and transmission stand (6). Make sure that hoses and harnesses do not get pinched or crushed as power plant is placed on the power plant stand.

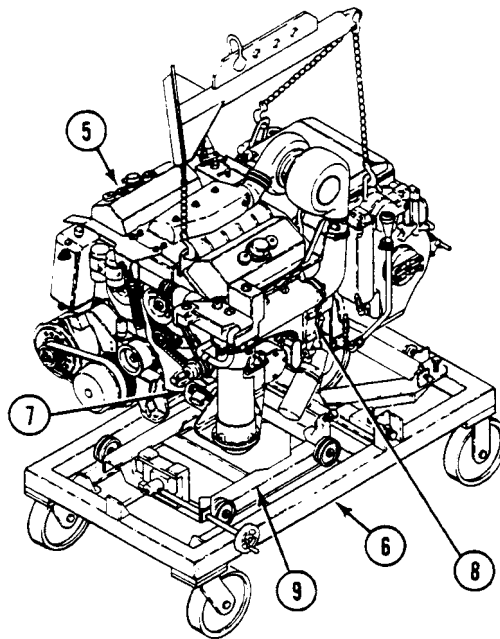

3. Position the engine so that the edge of the engine oil pan (7) and each side of the engine flywheel housing (8) are seated completely on the engine support (9).

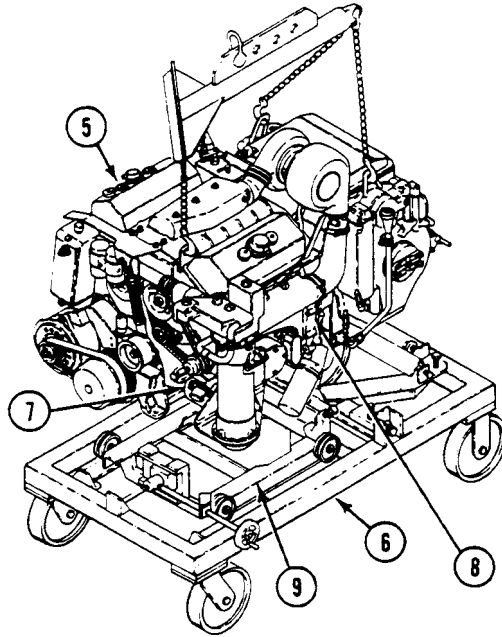

4. The lower rear side of the transmission should be against the edge of the transmission support stop (1).

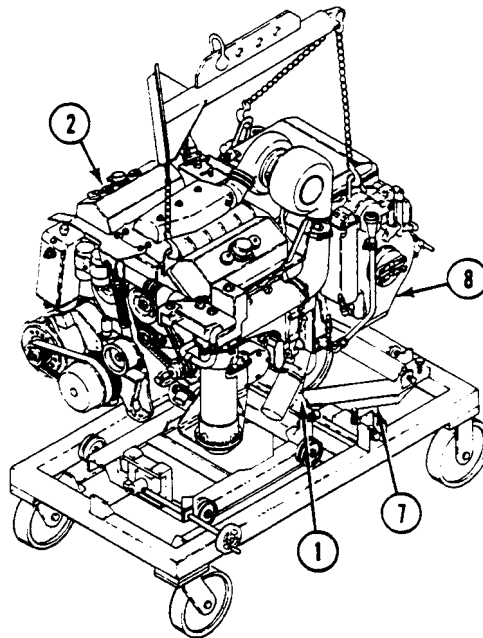

5. Release all tension on the power plant sling. Remove the power plant sling from the power plant (2).

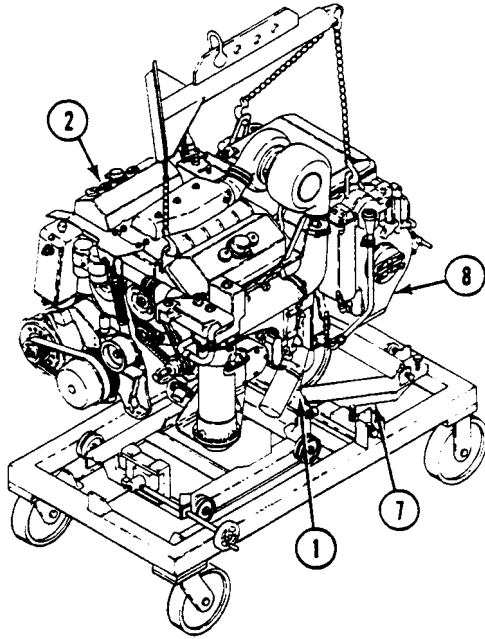

6. Loosen two jam nuts (3) securing beam assembly (4) to main frame (5). Loosen two screws (6) that hold transmission support (7).

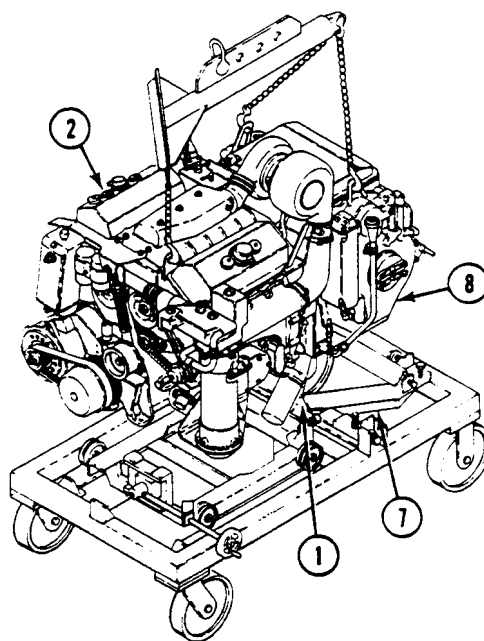
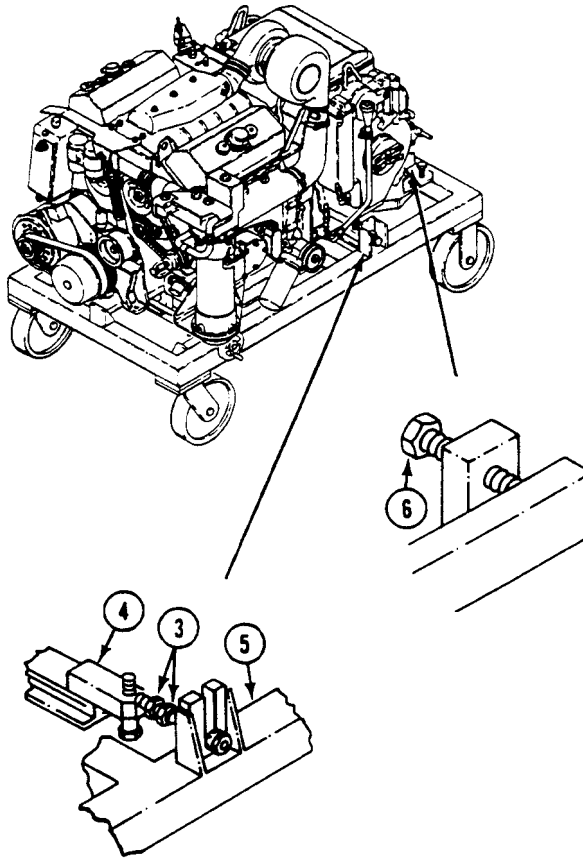

7. Turn each leveling screw (6) until the transmission support (7) is supporting the bottom of the transmission (8). All three contact points of the engine support should still be supporting the engine.

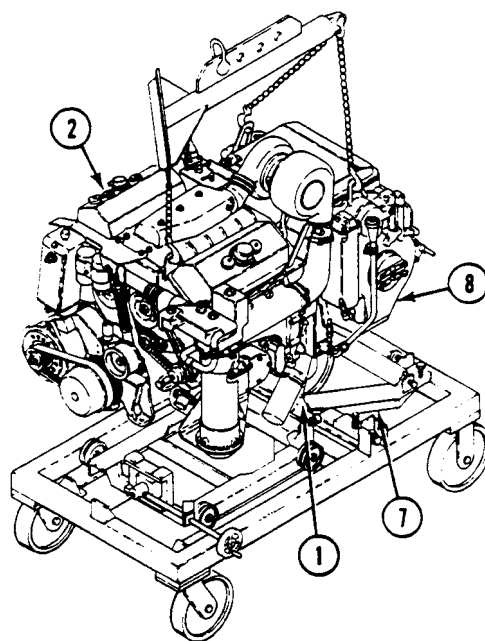
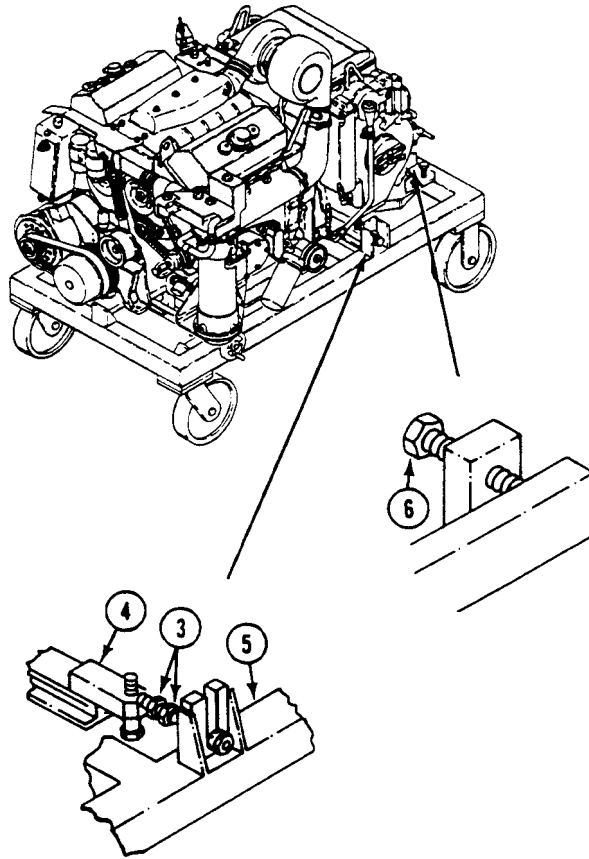

8. Tighten two jam nuts (3) to secure beam assembly (4). Tighten two screws (6) securing the transmission support (7) evenly.
9. If the transmission (8) shifts up or down when separated from the engine, it will be necessary to adjust the transmission support (7) to allow the transmission spline coupling to mate with the engine splined coupling. Repeat Steps 6 - 8.

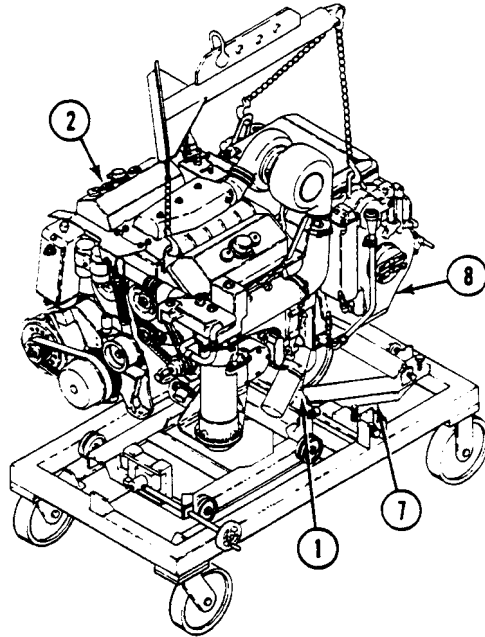

10. Adjust transmission to keep the transmission level with the engine during disassembly and assembly.

END OF TASK

SERVICE ENGINE AND TRANSMISSION STAND

0069 00

THIS WORK PACKAGE COVERS:

Servicing (page 0069 00-1).

INITIAL SETUP:

Maintenance Level

Direct Support

Personnel Required

Track Vehicle Repairer 63H10

Tools and Special Tools

Lubricating Kit (WP 0120 00, Item 37)

Materials/Parts

Automotive grease (WP 0122 00, Item 6)

Engine oil (WP 0122 00, Item 13)

SERVICING

WARNING

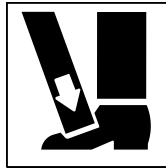

Engine support could fall and injure you. Make sure to secure engine support to the main frame before towing, lifting or transporting engine stand.

CAUTION

Engine stand jack screw could be damaged if the two screws and nuts attaching jack screw to main frame are not removed. Remove screws and nuts before towing, lifting or transporting an empty engine stand.

1. Extend jack screw (1) and clean exposed threads and all lubrication fittings.
2. Apply grease to lubrication fittings on caster wheels (2), casters (3), vee wheels (4), and jack screw (1). Remove excess grease.
3. Apply lubricating oil to handwheel tube (5) at bushing point.

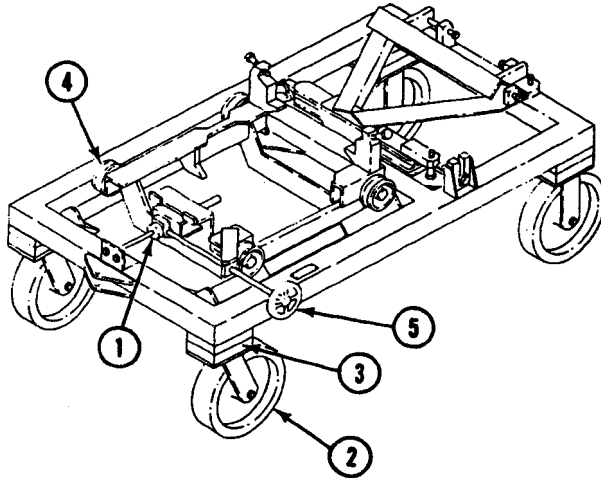

END OF TASK

REPAIR ENGINE AND TRANSMISSION STAND

0070 00

THIS WORK PACKAGE COVERS:

- Replace Caster Assembly (page 0070 00-2).
- Replace Engine Support Vee Wheels (page 0070 00-3).
- Replace Jack Screw (page 0070 00-6).
- Replace Beam Assembly Bearing (page 0070 00-10).
- Replace Data Plate (page 0070 00-13).
- Repair Engine and Transmission Stand By Welding (page 0070 00-14).

INITIAL SETUP:

Maintenance Level

Direct Support

Tools and Special Tools

- General Mechanic's Tool Kit (WP 0120 00, Item 62)
- Trailer Mounted Welding Shop (WP 0120 00, Item 69)
- Lubricating Kit (WP 0120 00, Item 37)
- Retaining Ring Pliers (WP 0120 00, Item 40)
- Arbor Press (WP 0120 00, Item 43)
- Trestle (WP 0120 00, Item 66)
- Open End Wrench, 1-5/16 x 1-1/2
(WP 0120 00, Item 72)
- Socket Wrench Set, 3/4 Inch Drive
(WP 0120 00, Item 78)

Materials/Parts

- Automotive grease (WP 0122 00, Item 6)
- Bearing
- Cotter pin
- Cotter pin (8)
- Drive screw (4)
- Headless pin (2)
- Lockwasher (4)
- Locknut
- Locknut
- Locknut
- Locknut (2)
- Locknut (4)
- Wooden block (2 x 4)

Personnel Required

- Track Vehicle Repairer 63H10
- Welder 44B10

References

- TM 9-237
-

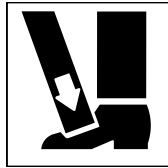
WARNING

Engine support could fall and injure you. Make sure to secure engine support to the main frame before towing, lifting or transporting engine stand.

CAUTION

Engine stand jack screw could be damaged if the two screws and nuts attaching jack screw to the main frame are not removed. Remove the screws and nuts before towing, lifting or transporting an empty engine stand.

REPAIR OR REPLACEMENT**REPLACE CASTER ASSEMBLY**

1. Raise corner of stand and install a trestle (1).

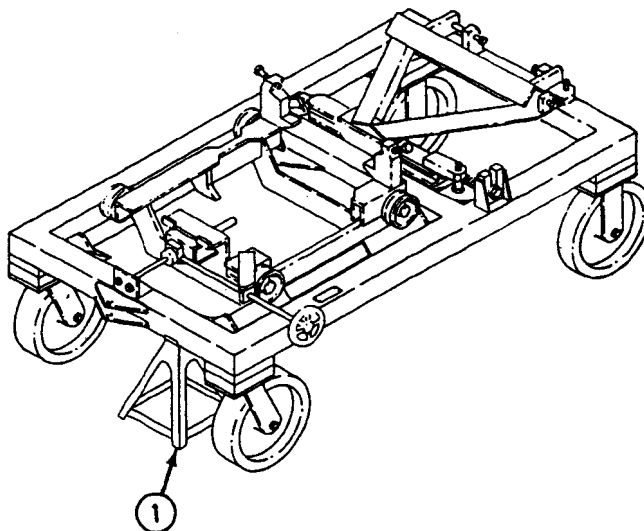

2. Remove four screws (1), lockwashers (2), and caster assembly (3) from main frame (4). Discard lockwashers.
3. Place caster (3) on main frame (4) and install four screws (1) and new lockwashers (2).
4. Lubricate caster (3). Use automotive grease.

5. Remove trestle (5) and lower stand (6).

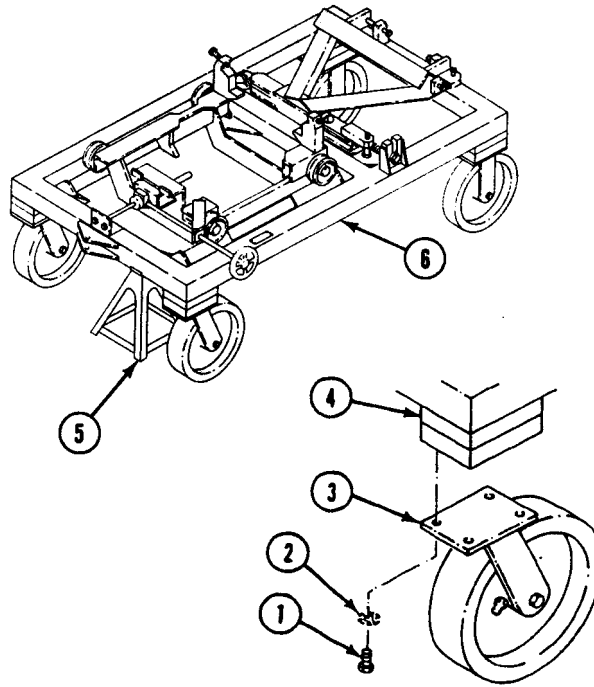

REPLACE ENGINE SUPPORT VEE WHEELS

1. Retract jack screw (7).
2. Remove two screws (8) and locknuts (9) securing jack screw (7) to main frame (4). Discard locknuts.

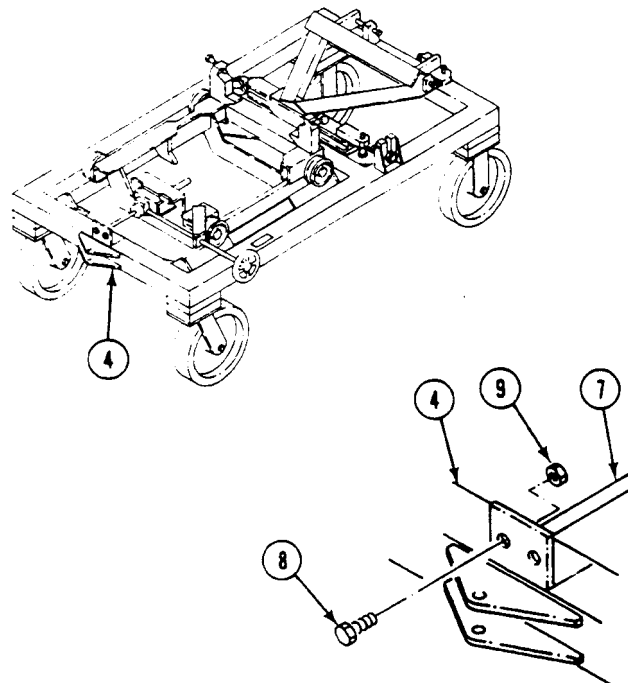

3. Raise support (10) and install wooden 2 x 4 (11) between frame rails (12). Rest support on 2 x 4.
4. Remove cotter pin (13), washer (14), vee wheel (15), and washer (14). Discard cotter pin.

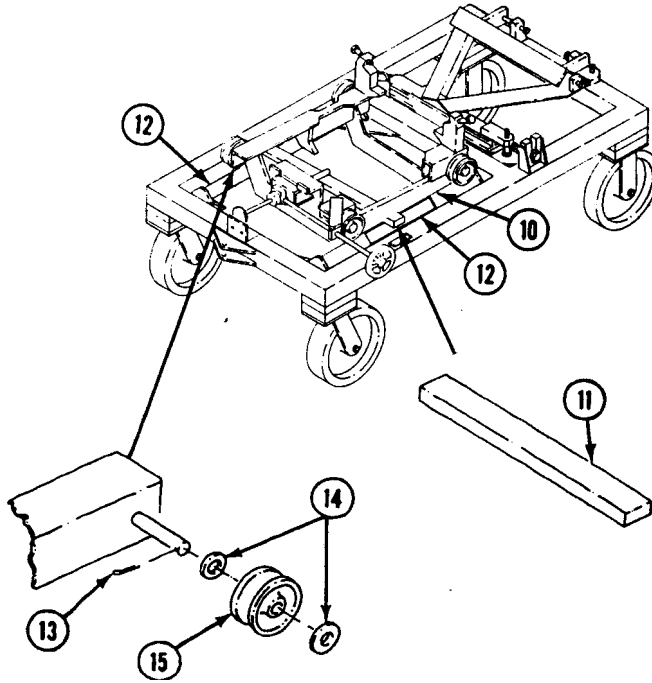

5. Remove screw (1) and locknut (2) securing axle (3) to support (4). Remove axle. Discard locknut.

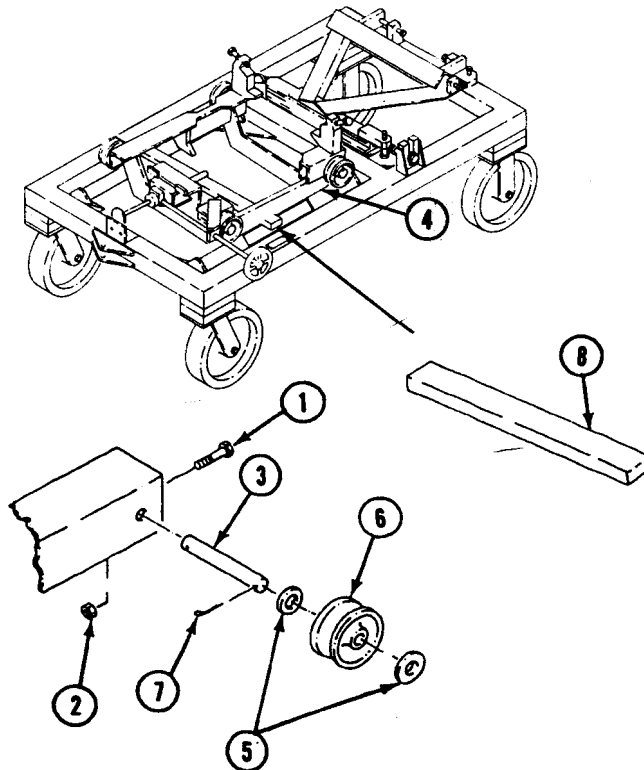

6. Install axle (3), screw (1), and new locknut (2).
7. Install washer (5), vee wheel (6), washer (5), and new cotter pin (7).
8. Lubricate vee wheel (6). Use automotive grease.
9. Raise support (4), remove 2 x 4 (8), and lower wheels onto track.

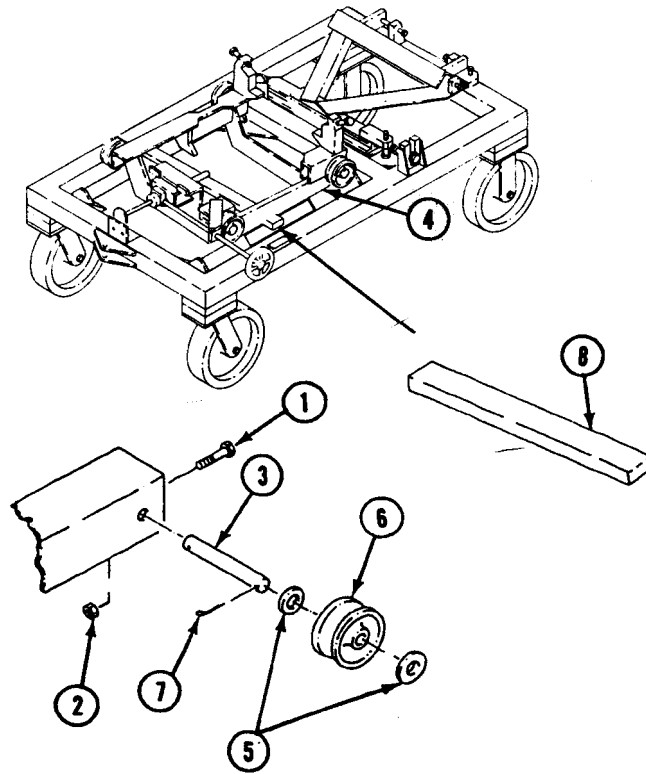

10. Install two screws (8) and new locknuts (9) securing jack screw (7) to main frame (4).

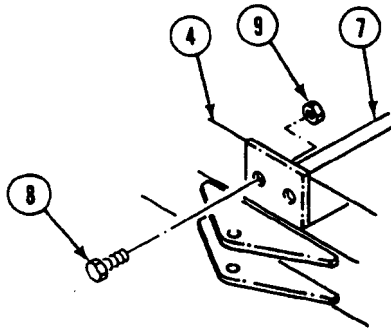

REPLACE JACK SCREW

1. Retract jack screw (11). Dowel pin behind bracket bushing should be horizontal and keyway in end of hand wheel tube pointing up.

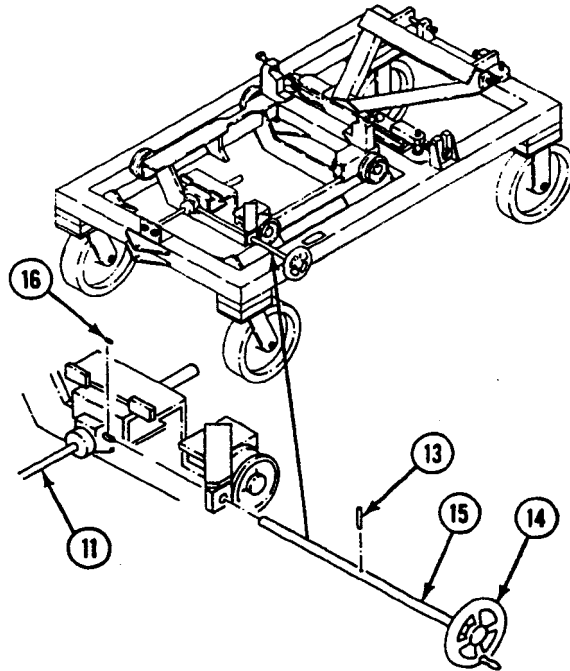

2. Drive out pin (13). Discard pin.
3. Remove hand wheel (14) and tube (15). Be careful not to lose key (16).

NOTE

If hand wheel or tube requires replacement, go to Step 4, if not, go to Step 7.

4. Remove handle (1) from hand wheel (2).

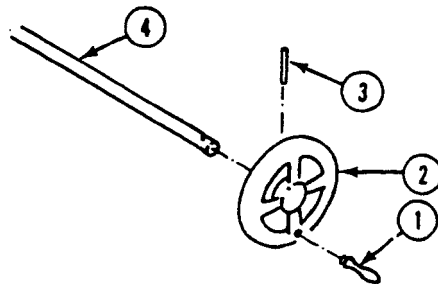

5. Drive out pin (3) from hand wheel (2). Discard pin.
6. Install hand wheel (2) on tube (4). Align dowel holes and install new pin (3).

NOTE

If hand wheel bushing requires replacement, go to Step 7. If not, go to Step 11.

7. Remove screw (5) and locknut (6) securing bracket (7) to engine support (8). Remove bracket. Discard locknut.

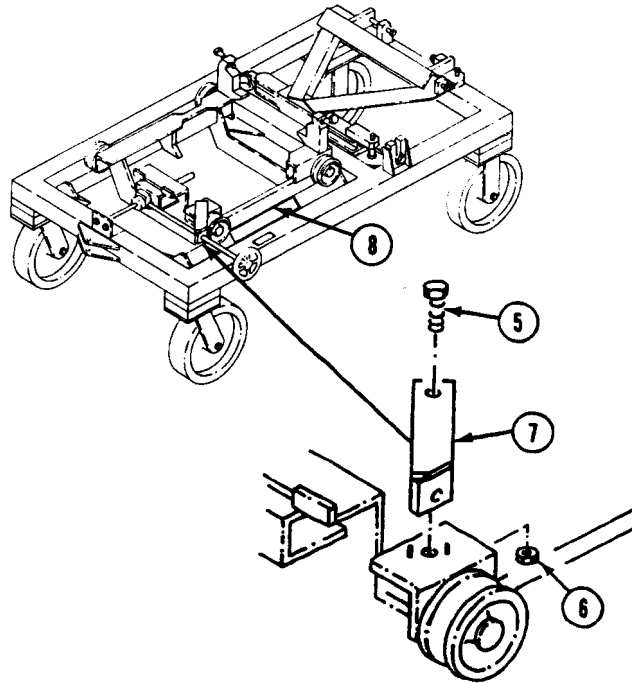

8. Place bracket (7) in press and push out bushing (9). Note which side of bracket bushing flange was on.
9. Press new bushing (9) into bracket (7).

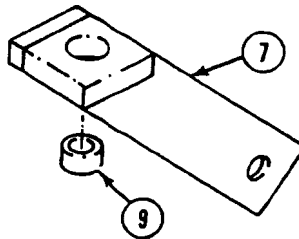

10. Place bracket (7) over dowels (10) and install screw (5) and new locknut (6).

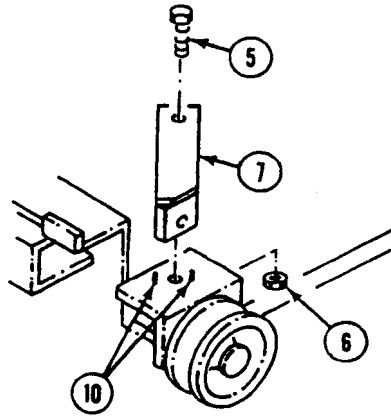

11. Remove four screws (1), locknuts (2), and jack screw (3) from main frame (4) and engine support (5). Discard locknuts.

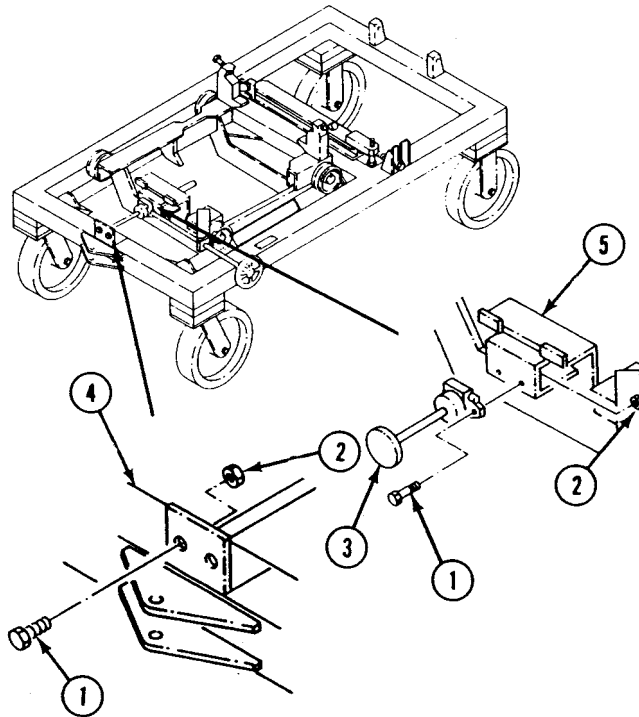

12. Place new jack screw (3) on engine support (5) and main frame (4). Install four screws (1) and new locknuts (2).
13. Install key (6) into jack screw keyway (7).

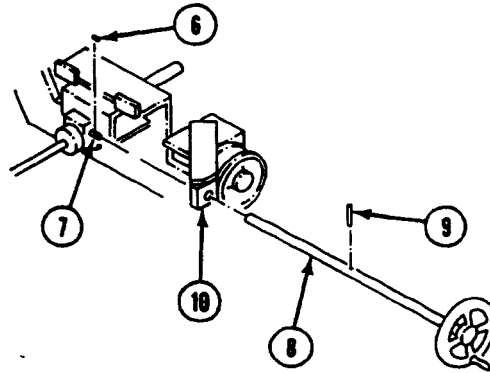

14. Install hand wheel tube (8).
15. Install new pin (9) behind bracket bushing (10).
16. Lubricate jack screw (3). Use automotive grease.

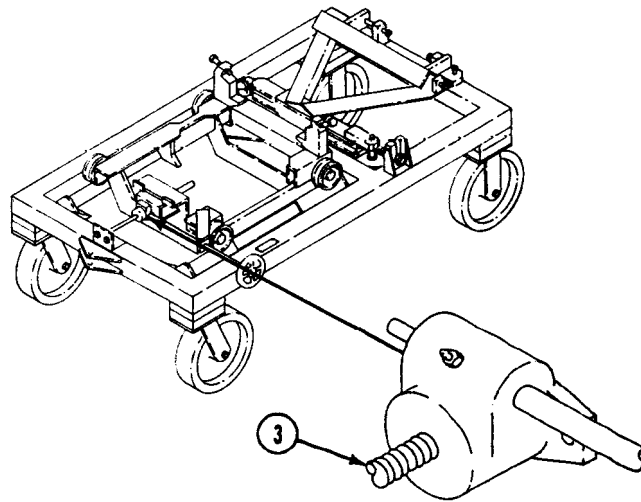

REPLACE BEAM ASSEMBLY BEARING

1. Remove screw (11), locknut (12), long spacer (13), and short spacer (14) securing transmission support (15) to beam assembly (16). Discard locknut. Remove support.

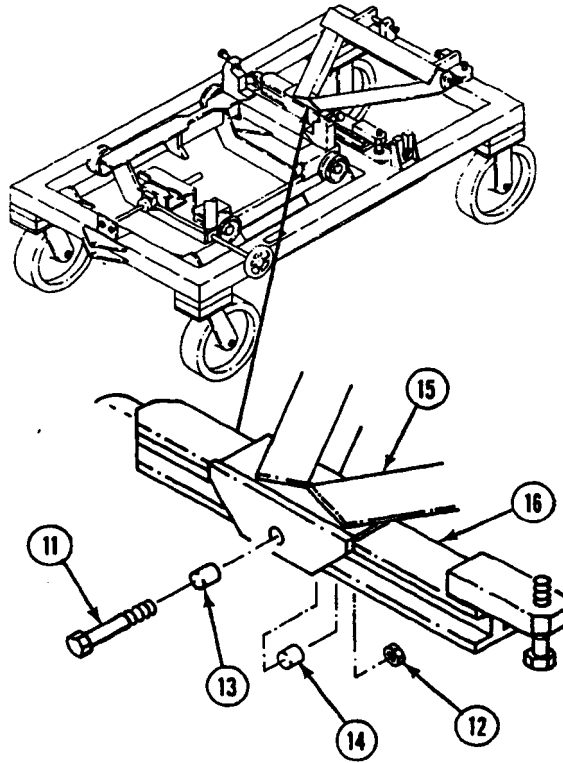

2. Loosen two jam nuts (1) securing beam assembly (2) to main frame (3).
3. Remove cotter pin (4) from headless pin (5) securing beam assembly (2) to main frame (3) and remove headless pin (5). Discard cotter pin. Remove beam from main frame.

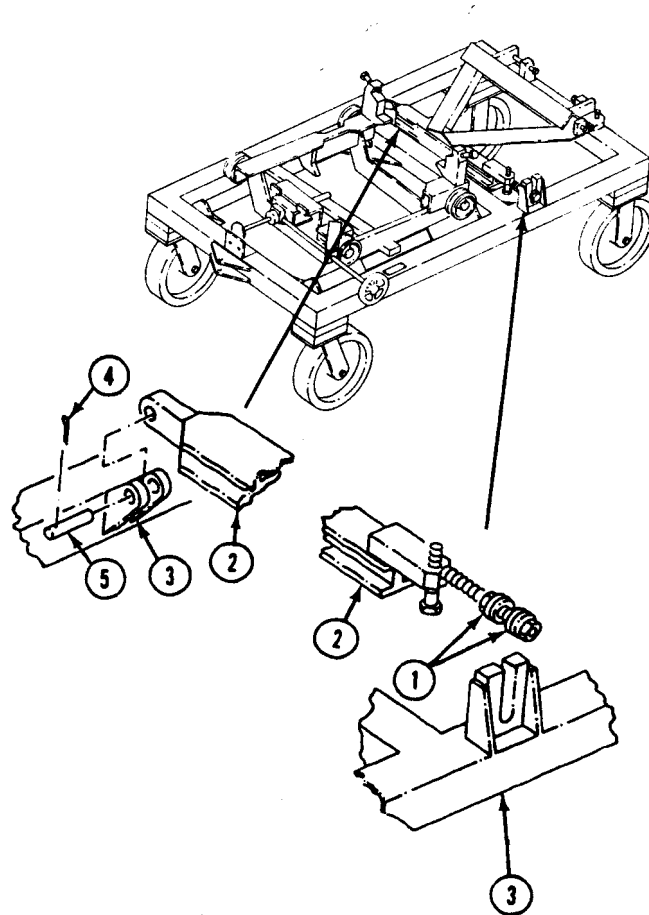

4. Place beam assembly (2) on workbench.

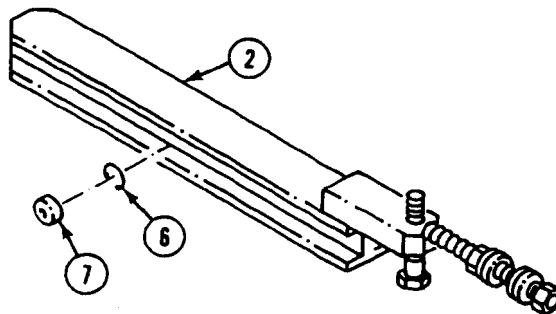

5. Remove retaining ring (6) securing bearing (7).
6. Push bearing (7) out of beam assembly (2).
7. Install new bearing (7).
8. Install retaining ring (6) on beam assembly (2).

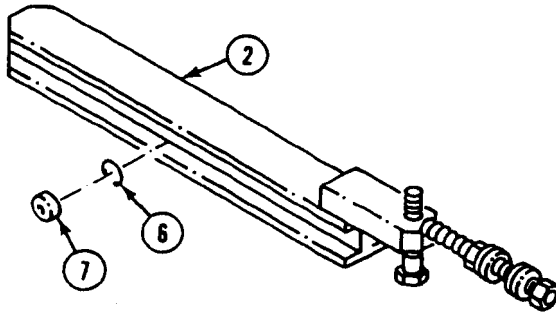

9. Install beam assembly (2) on main frame (3) and install headless pin (5). Install new cotter pin (4).
10. Tighten jam nuts (1).

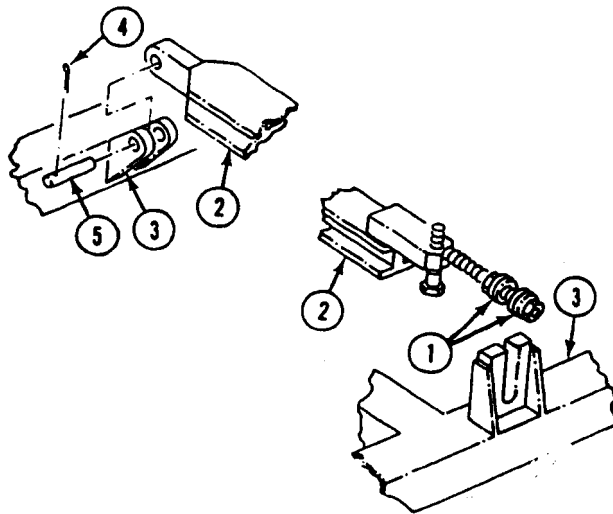

11. Position transmission support (1) on beam assembly (2). Install short spacer (3), beam assembly, long spacer (4), screw (5), and new locknut (6) on transmission support.

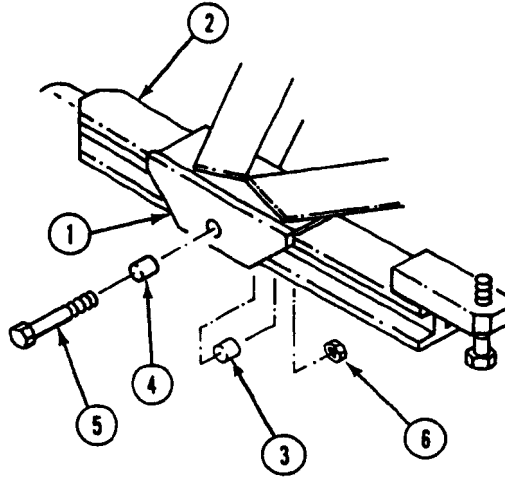

REPLACE DATA PLATE

1. Remove four drive screws (7).
2. Locate new data plate (8) in same area. Using plate as a template, drill four mounting holes $3/64 - 1/16$ inch diameter.
3. Install four new drive screws (7).

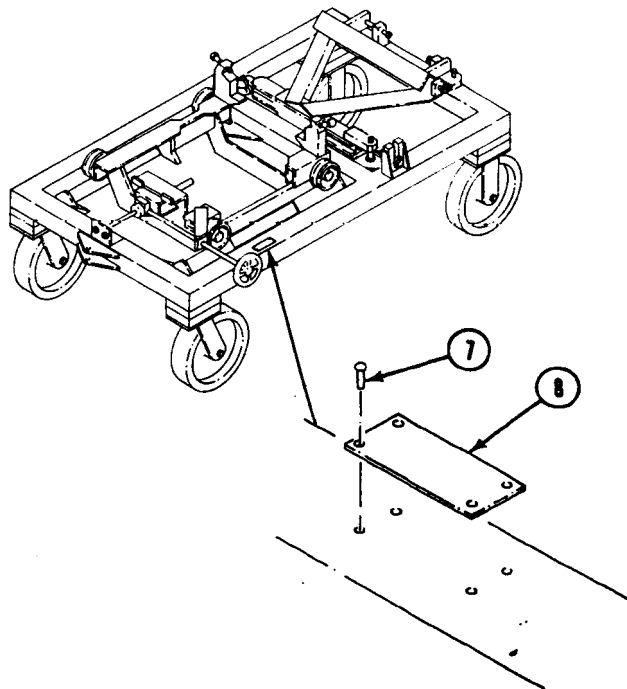

REPAIR ENGINE AND TRANSMISSION STAND BY WELDING

1. Weld in accordance with TM 9-237 using the gas tungsten-arc welding (GTAW) process, the shielded metal-arc welding (SMAW) process or the gas metal-arc welding (GMAW) process.
2. Material: bar and plate hot rolled carbon steel AISI 1020; tubing ASTM-A501, angle ASTM-A36.

END OF TASK

CHAPTER 15

DIRECT SUPPORT MAINTENANCE INSTRUCTIONS
FOR AUXILIARY GENERATOR

WORK PACKAGE INDEX

Title

Sequence No.

REPAIR AUXILIARY POWER UNIT COVER (M577A3 and M1068A3 ONLY).....0071 00

REPAIR AUXILIARY POWER UNIT COVER (M577A3 AND M1068A3 ONLY)

0071 00

THIS WORK PACKAGE COVERS:

Inspection of Installed Items (page 0071 00-1).
 Repair or Replacement (page 0071 00-2).

INITIAL SETUP:

Maintenance Level

Direct Support

Personnel Required

Fabric Repairman 43M20

Tools and Special Tools

Industrial Sewing Machine (WP 0120 00, Item 51)

References

See your -10
 FM 10-16

Materials/Parts

Adhesive sealant (WP 0122 00, Item 3)
 Vinyl coated nylon cloth (WP 0122 00, Item 34)

Equipment Condition

Cover removed from carrier (see your -10)

INSPECTION OF INSTALLED ITEMS

1. Check fabric. Weak or torn areas may be repaired by a cement patch or machined patch. All material used to repair the cover must be the same as the original material.
2. Check tensile strength of fabric. Grasp a small fold of fabric between thumb and forefinger of each hand, gripping it closely so tips of forefingers touch. Tug material several times. If it does not rip, it is repairable. If it tears on first tug, test several areas for extend of damage. Weak sections must be replaced.
3. Check for spots and stains. Non-wear spots and stains are all right if fabric has been brushed clean. Repair fabric where fabric strength has been weakened by mildew, sap, or dirt stains.
4. Check fabric. Repair opened seams, runoff stitching, and broken threads. Restitch worn stitching.
5. Check webbing straps. Repair or replace worn, frayed, or torn straps.
6. Check buckles. Replace buckles that are bent, broken, or missing.
7. Check for slide fasteners (zippers). Replace zippers that are rusted or do not work correctly.

8. Check eyelets, washers, and studs. Replace parts that are bent, broken, or missing.

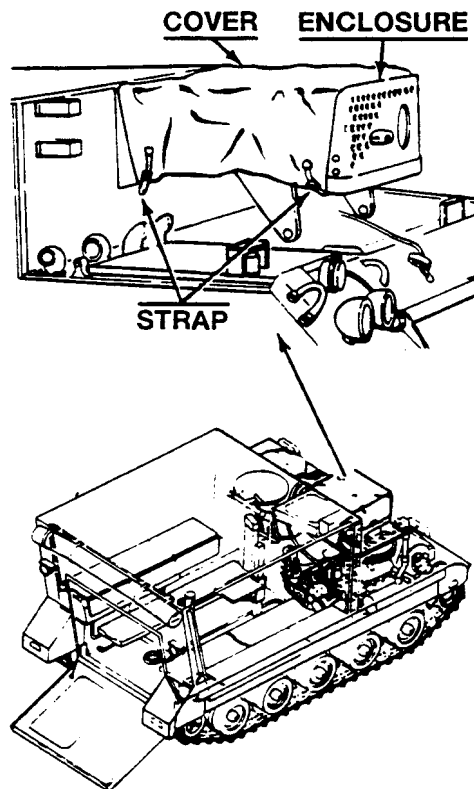

REPAIR OR REPLACEMENT

NOTE

The materials used to make a cement patch are adhesive, round patch of vinyl coated nylon cloth, roller, board, wire brush, and soft bristle brush.

1. Select patch that overlaps damaged area with a margin of at least 3/4 inch (19 mm) on all sides.
2. Place board under damaged area for a flat working surface.
3. Buff patch and damaged area of fabric with wire brush.

WARNING



Adhesive is flammable and can injure you. Keep it away from heat, sparks, and open flame. Avoid repeated or prolonged breathing of vapors. Avoid contact with your skin.

4. Center patch over damaged area. Apply adhesive to patch and patch edge, making a circle on fabric with soft bristle brush.
5. Lift patch. Apply adhesive to area of fabric inside adhesive circle.
6. Allow adhesive to dry until tacky (about 10 minutes).
7. Press cement surfaces together firmly with roller while tacky.
8. Seal by wiping edge of patch with soft bristle brush.
9. Install or repair webbing using machine stitching in a square pattern with diagonal stitches from corner to corner.

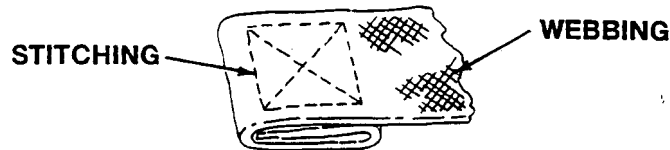

10. Repair hardware as shown in the following figure. See FM 10-16 for installation of eyelets and studs with washers.

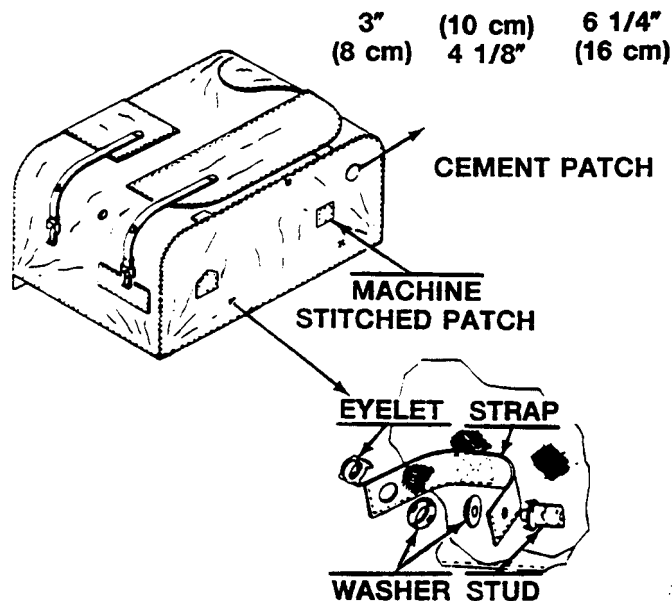

NOTE

Use lock stitching when you install patches, flaps, and straps or repair open seams. Use polyester thread and smallest needle you can to make weatherproof seams. Allow 5 to 7 stitches per inch (3 cm). Backstitch all thread breaks at least 1 inch (3 cm). Backstitch all ends at least 1 inch (3 cm), except where ends are turned under in a hem or seam or held down by other stitching. Maintain thread tension so stitching is tight and lock is fixed firmly in center of material. Trim all ends. Take care when restitching to make a new stitch line.

11. Repair extensive damage between seams Steps 12 - 22.
12. Open seam 2 inches (5 cm) beyond damaged area on both sides.
13. Square off damaged area from seam to seam.
14. Cut patch 2 inches (5 cm) wider than squared-off section. Allow for 3/4 inch (19 mm) turnunder on sides.
15. Center patch over cutaway section. Turn sides under, and reform double-felled seams at top and bottom.
16. Finish by stitching patch into place. Secure patch to cover with a second row of stitching. Place second row 3/8-1/2 inch (10-13 mm) from first.

NOTE

The watershed patch is a patch with the top edge angled off to give a roof effect. Because the roof type patch sheds water, the patch lasts longer than a square patch.

17. Use watershed patches, as needed.

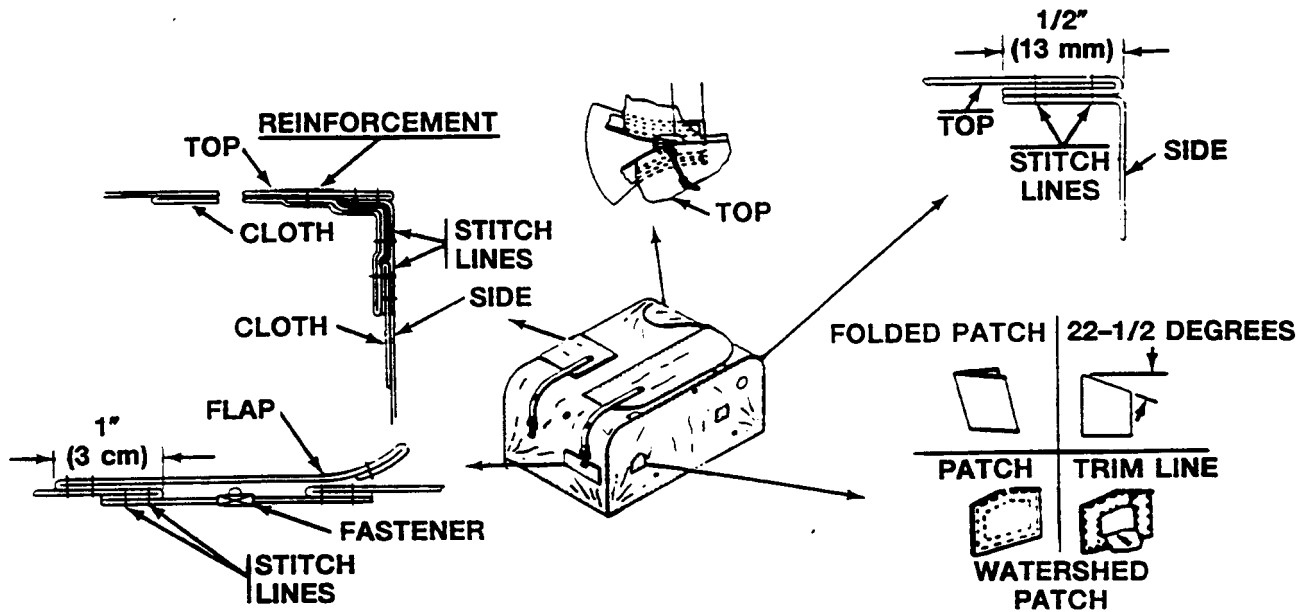

18. Cut patch large enough to overlap 2 inches (5 cm) on all sides of area to be repaired. Allow for 3/4 inch (19 mm) turn under of edge.
19. Fold patch in half lengthwise. Cut from open edges to folded edge at 22 1/2 degree angle as shown in illustration.
20. Center patch over damaged area. Turn under patch edges and stitch in place with a row of stitching no more than 1/8 inch (3 mm) from edge.
21. Secure patch to cover with a second row of stitching. Place second row 3/8-1/2 inch (10-13 mm) from first.
22. Turn material over. Cut away damaged area, notch corners, and turn edges in. Stitch turned-in edges to patch with a row of stitching no more than 1/8 inch (3 mm) from edge.

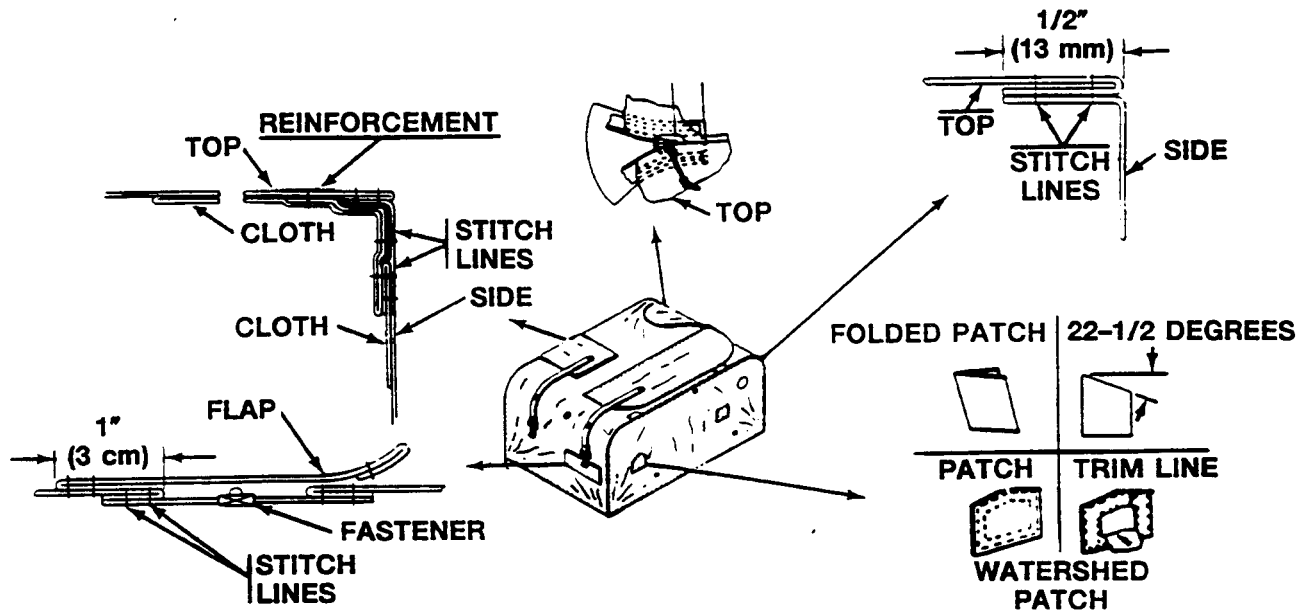

FOLLOW-THROUGH STEPS

1. Stow or install cover on carrier (see your -10).

END OF TASK

CHAPTER 16

DIRECT SUPPORT MAINTENANCE INSTRUCTIONS
FOR MAINTENANCE OF SPECIAL PURPOSE KITS

WORK PACKAGE INDEX

<u>Title</u>	<u>Sequence No.</u>
INSTALL PERSONNEL HEATER KIT (M113A3, M1059A3, AND M58 ONLY).....	0072 00
INSTALL PERSONNEL HEATER KIT (M1064A3 ONLY).....	0073 00
REPAIR PERSONNEL HEATER ASSEMBLY.....	0074 00
INSTALL ENGINE COOLANT HEATER KIT (M113A3 AND M1059A3).....	0075 00
ENGINE COOLANT HEATER DATA.....	0076 00
FINAL TEST -- COOLANT HEATER.....	0077 00
REPLACE FUEL CONTROL VALVE.....	0078 00
REPLACE RESTRICTION THERMOSTAT.....	0079 00
REPLACE OVERHEAT THERMOSTAT.....	0080 00
REPLACE FIXED RESISTOR.....	0081 00
REPLACE BURNER PACKING AND GASKET.....	0082 00
REPLACE DIODE AND MOTOR RESISTOR.....	0083 00
REPLACE BLOWER MOTOR.....	0084 00
INSTALL NON-SKID RAMP KIT (M1064A3 ONLY).....	0085 00
INSTALL CAPSTAN KIT (M1059A3 ONLY).....	0086 00
INSTALL ANCHOR KIT (M1059A3 ONLY).....	0087 00
INSTALL COMMANDER'S CUPOLA ARMOR SHIELDS (M113A3 AND M1064A3 ONLY).....	0088 00

INSTALL PERSONNEL HEATER KIT (M113A3, M1059A3, AND M58 ONLY)

0072 00

THIS WORK PACKAGE COVERS:

Installation (page 0072 00-2).

INITIAL SETUP:

Maintenance Level

Direct Support

Tools and Special Tools

Automotive Fuel and Electrical System Repair Tool Kit
(WP 0120 00, Item 59)

Hacksaw frame (WP 0120 00, Item 17)

Materials/Parts

Adhesive (WP 0122 00, Item 1)

Hacksaw blade (WP 0122 00, Item 15)

Personnel Heater Kit P/N 12349702

Personnel Required

Fuel and Elec Sys Rep 63G10

References

See your -10

See your -20

Equipment Condition

Engine stopped (see your -10)

Carrier blocked (see your -10)

Ramp lowered (see your -10)

Battery ground strap disconnected (see your -20)

Power plant rear access panels removed (see your -20)

Floor plates removed (see your -20)

Both main fuel tank shutoff valves off (see your -10)

INSTALLATION

NOTE

Flareless (compression) fittings are used on the fuel lines. When these fittings are first installed, a sleeve is crimped on the tube or hose end. Consequently, when tubes or hoses are replaced, new fitting sleeves are also required.

1. Remove six screws (1), two cover plates (2), and two gaskets (3) from top of carrier. Discard cover plates and gaskets.
2. Remove locknut (4) and screw (5) from transverse beam. Discard locknut and screw.
3. Remove locknut (6) and screw (7) from engine compartment bulkhead. Discard locknut and screw.
4. Remove four locknuts (8) and screws (9) from engine compartment bulkhead. Retain four locknuts and screws.

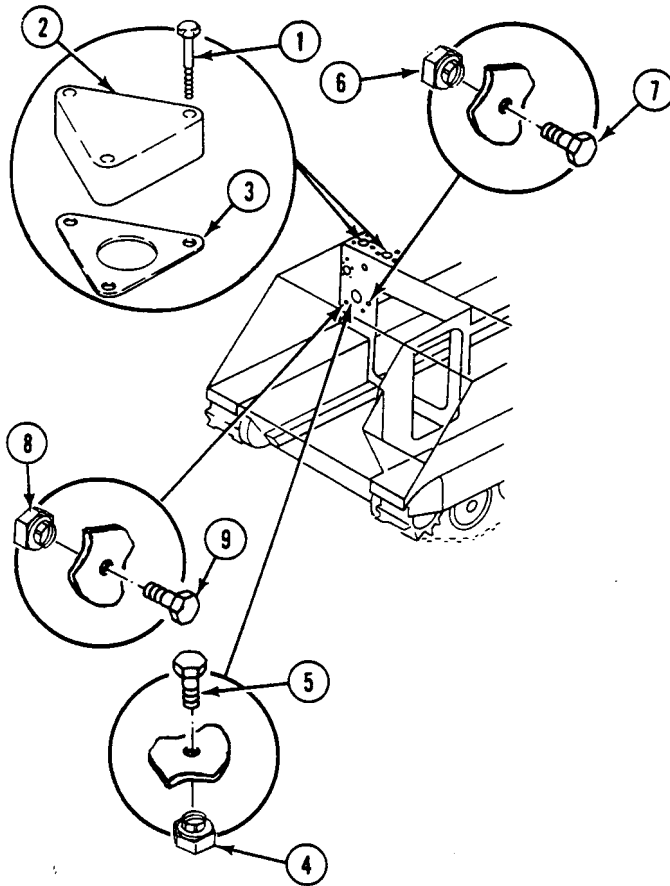

5. Remove four locknuts (1), screws (2), cover (3), and gasket (4) from engine compartment bulkhead. Retain four locknuts; discard screws, cover, and gasket.
6. Remove two locknuts (5), screws (6), retainer (7), cover (8), and gasket (9) from engine compartment bulkhead. Discard locknuts, screws, retainer, cover and gasket.

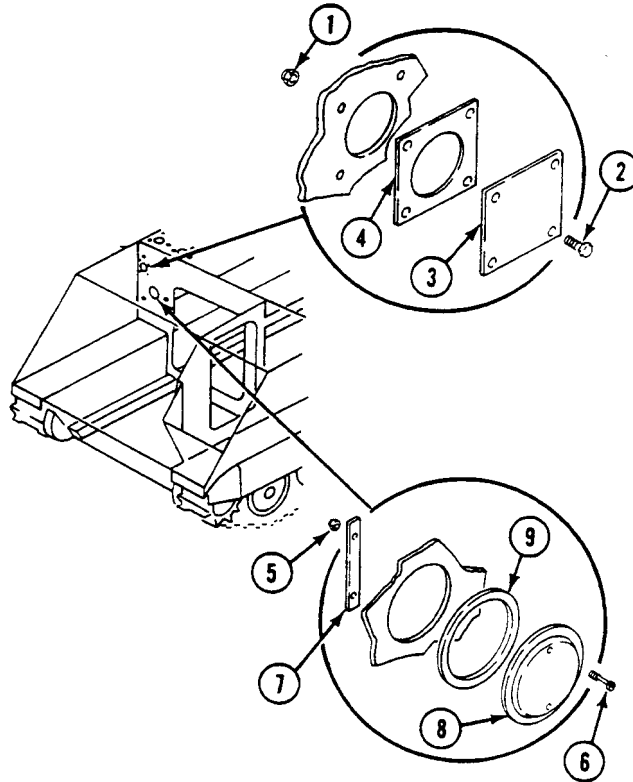

7. Install grommet (10) in power plant bulkhead.
8. Install exhaust pipe (11) in grommet (10).
9. Install exhaust pipe (12) on exhaust pipe (11).
10. Secure two exhaust pipes (12) and (13) and two gaskets (14) to power plant bulkhead with four screws (15) and retained locknuts (16).

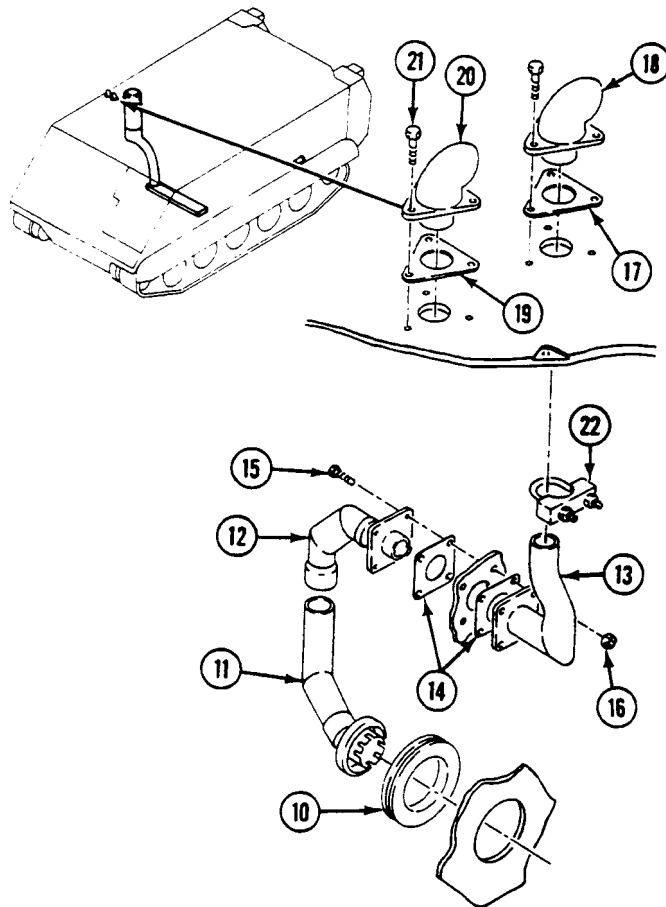

11. Install gasket (17) on exhaust elbow (18) and insert elbow through top deck into exhaust pipe (13).
12. Install gasket (19) on intake elbow (20) and position elbow through top deck opening.
13. Secure exhaust and intake elbows (18) and (20) to top deck with six screws (21).
14. Secure exhaust pipe (13) to elbow (18) with loop clamp (22).

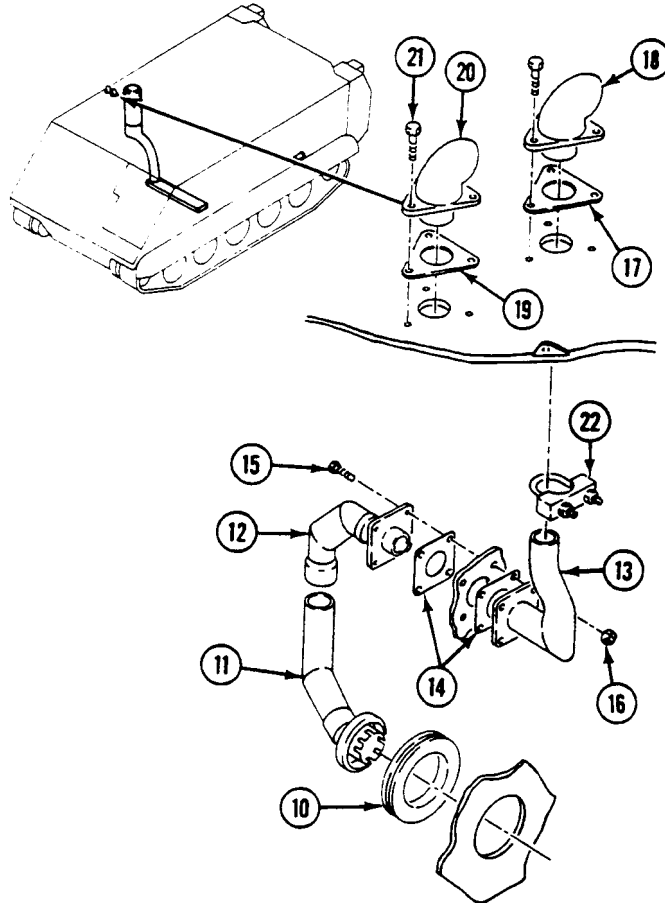

15. Secure plenum (1) to heater (2) with four lockwashers (3) and screws (4).

NOTE

Four locknuts and screws were previously removed and retained. However, screw that secures ground strap is supplied in the personnel heater kit.

For model A20, P/N 5000-30178 heaters, the ground strap is attached to the top of the heater.

16. Secure two saddles (5) to power plant bulkhead with four retained screws (6), three lockwashers (7), ground strap (8), and four retained locknuts (9).
17. Install two clamps (10) in two saddles (5).
18. Position clamp (11) on heater intake port (12) and clamp (13) on heater exhaust pipe (14). Do not tighten.
19. Install elbow (15) in heater intake pipe (12) and intake elbow (16).
20. Align inlet elbow (15) with intake elbow (16) and exhaust port (14) with exhaust pipe in carrier. Place heater (2) and shield (17) against saddles (5).
21. While still supporting heater, double check for proper mating of heater exhaust port (14) and exhaust pipe in carrier. Tighten saddle clamps (10).
22. Position ground strap (8) on heater (2). Secure with one lockwasher (18) and screw (19). Discard existing screw and use screw provided in kit.
23. Tighten clamp (13) on heater exhaust port (14) and exhaust pipe in carrier.
24. Tighten clamp (11) on heater intake pipe (12).

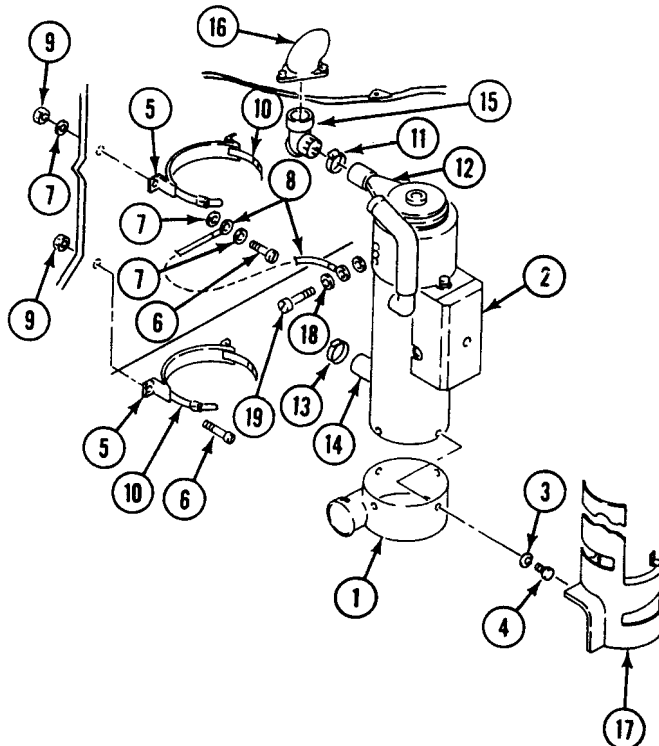

25. Secure fuel pump (1) to threaded bracket (2) with four lockwashers (3), two flat washers (4), and screws (5).

NOTE

Shielded lead must be secured to weldnut to ensure proper grounding and operation of fuel pump.

26. Secure shielded lead (6) to weldnut (7) with washer (8), two lockwashers (9), and screw (10).

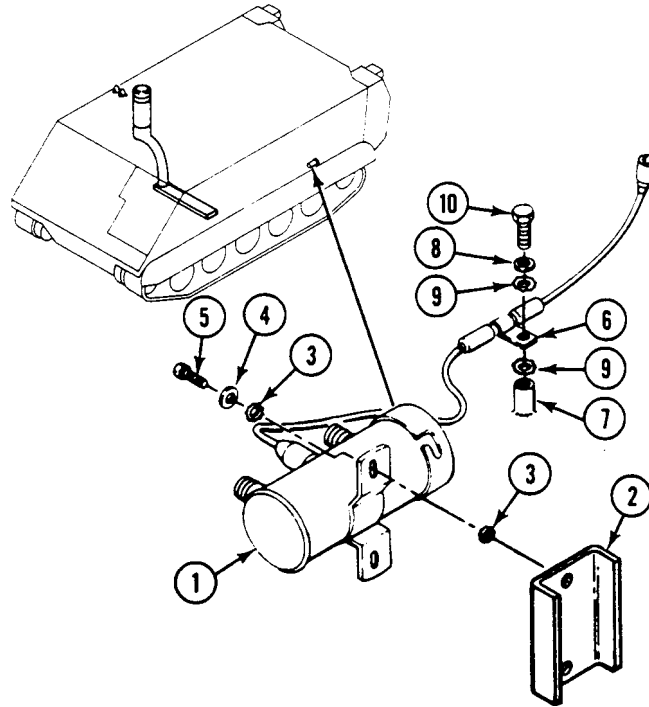

27. Install adapter (11) on hose end (12).
28. Install personnel heater fuel hose (12) on outlet side of fuel pump (13).
29. Apply a thin coat of adhesive to external tapered threads of fittings.
30. Install coupling (14) on inlet side of fuel pump (13).

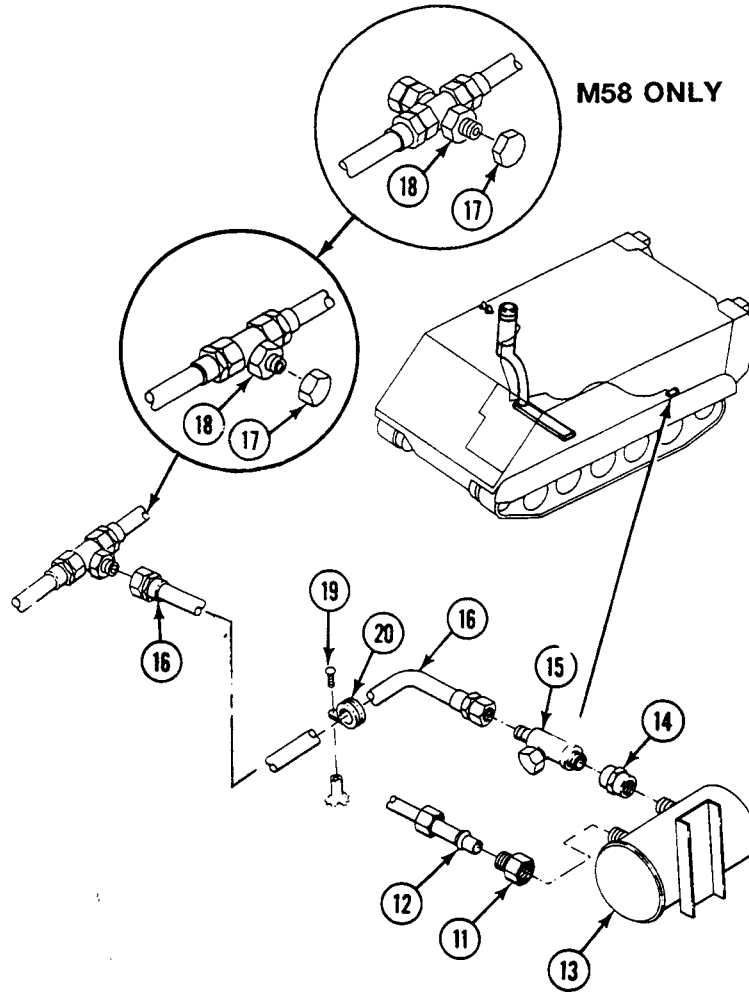

31. Install tee (15) on coupling (14).
32. Secure personnel heater fuel hose (16) to tee (15).
33. Apply a thin coat of adhesive to clean external tapered threads of fittings.
34. Remove cap (17) from reducer (18).

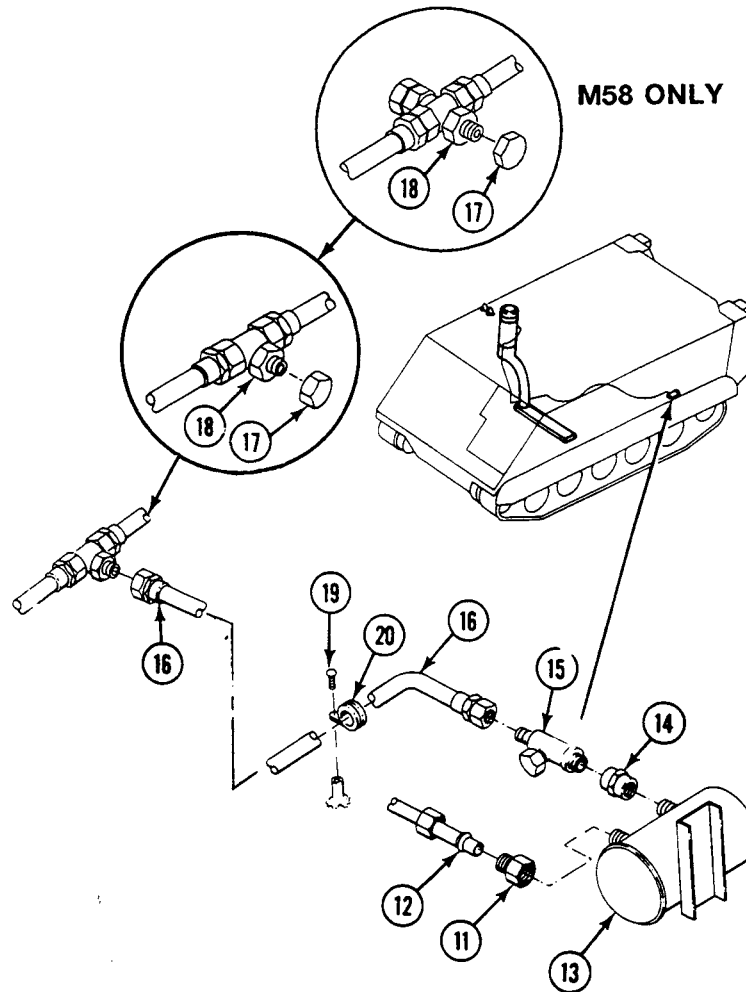

35. Secure personnel heater fuel hose (16) to reducer (18).
36. Remove screw (19) from weldnut.
37. Install clamp (20) on hose (16). Secure clamp (20) to weldnut on hull using screw (19).

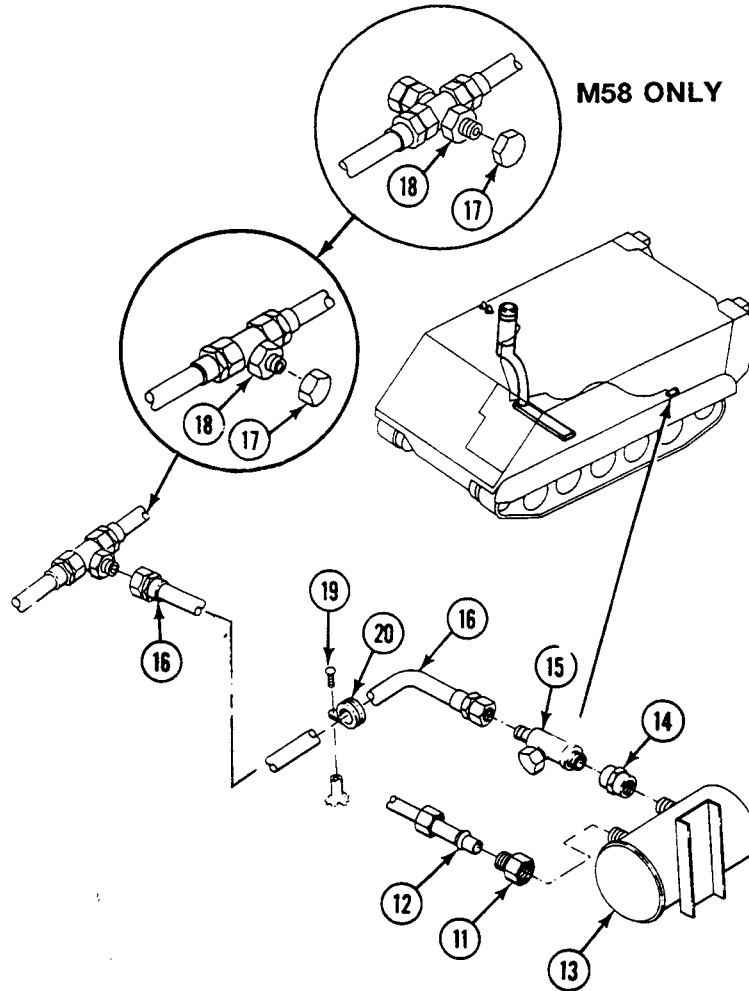

38. Remove locknut (1) and screw (2) from crossmember. Discard locknut and screw.

NOTE

Remove both nuts, sleeves and locknut prior to installing nipple through crossmember.

39. Install nipple body (3) through crossmember and secure with locknut (4).
 40. Install nut (5) and sleeve (6) on hose end (7).
 41. Secure personnel heater fuel hose (7) to nipple body (3).

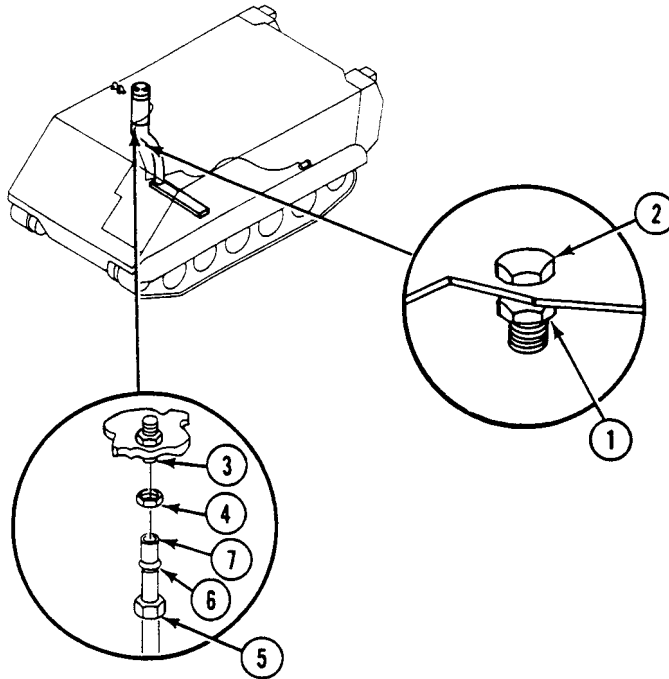

42. Remove eight screws (8) from eight weldnuts (9).
 43. Secure personnel heater fuel hose (7) to eight weldnuts (9) with eight screws (8) and clamps (10).

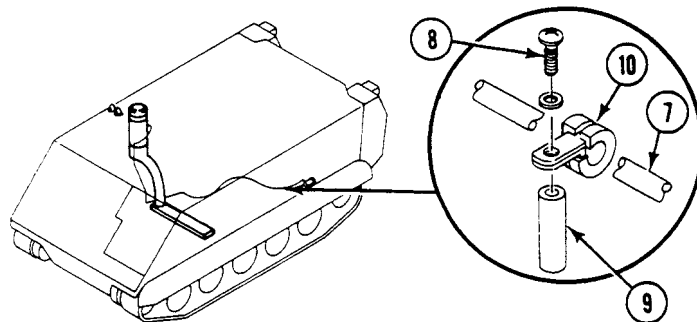

NOTE

Disassemble elbow assembly before installing through bulkhead.

44. Apply a thin coat of adhesive to clean external tapered threads of fittings.
45. Secure elbow (11) to power plant bulkhead with locknut (12).
46. Install nut (13) and sleeve (14) onto tube (15).
47. Secure tube (15) to nipple body (3).
48. Secure tube (15) to elbow (11).
49. Secure tube (15) to weldnut (16) with clamp (17), washer (18), and screw (19).

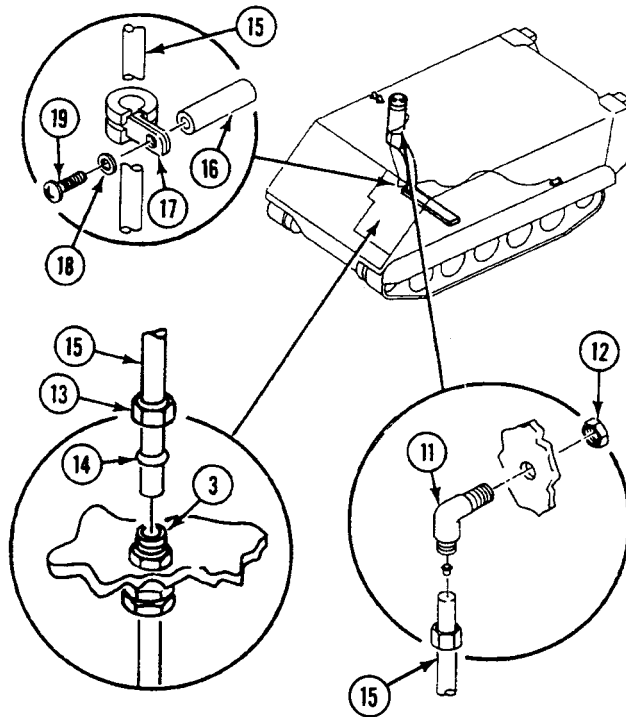

50. Install fuel filter bracket (1) in hull. Secure with two screws (2), washers (3), and lockwashers (4).
51. Install fuel filter (5) in bracket (1). Secure with two screws (6), washers (7), and new locknuts (8).

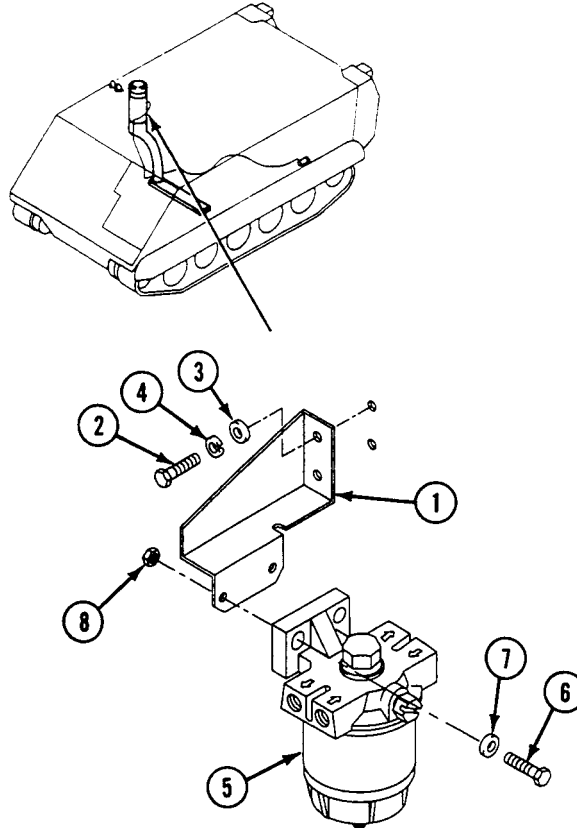

52. Install valve (12) on adapter (11) with valve knob on top.
53. Apply sealant to clean external tapered threads of elbow (13). Install elbow (13) in valve (12), adapter (11), and new packing (22) in fuel filter (5).
54. Install elbow (14) on elbow (15) on engine compartment bulkhead.
55. Connect inlet fuel hose (16) to elbow (13) and elbow (14).

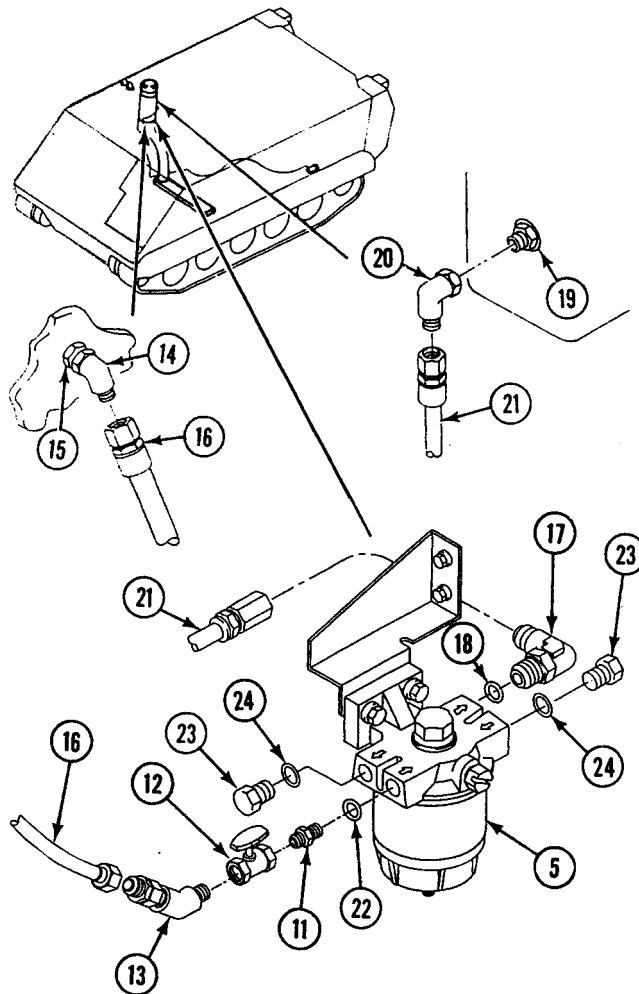

56. Install two plugs (23) and new packings (24) in fuel filter (5).
57. Install elbow (17) and new packing (18) in fuel filter (5).
58. Apply sealant to clean external threads of fittings. Install nipple (19) in personnel heater and install elbow (20) on nipple with elbow facing down.
59. Connect heater inlet fuel line (21) to elbow (20) and elbow (17).

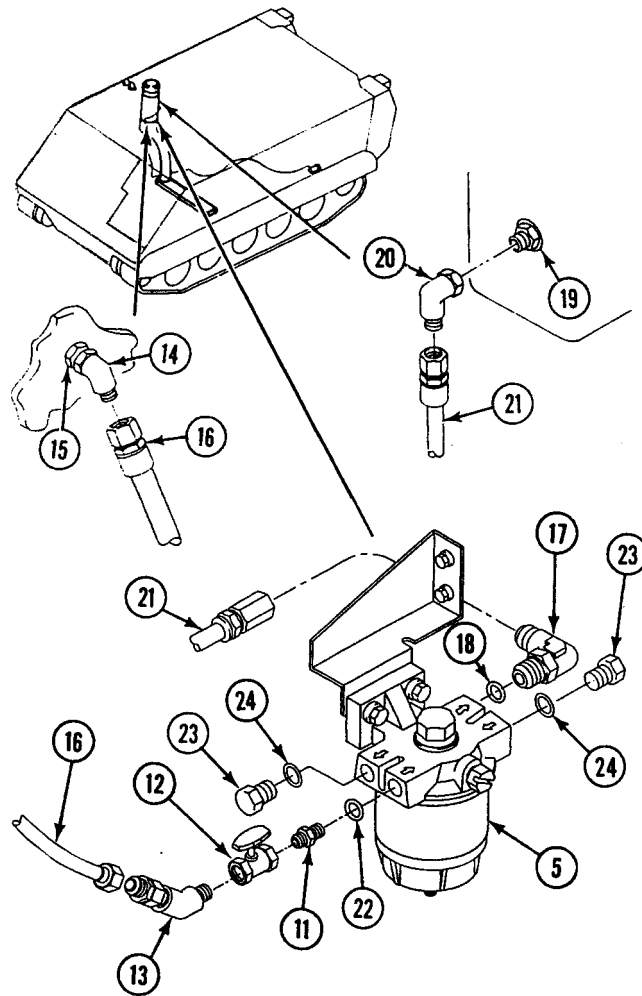

60. If required, use a hacksaw to trim ends of personnel seat (1) and seat back (2), so heater hose may be installed.
61. Secure left and right floor plates (3) to hull crossmembers with seven screws (4) and washers (5).

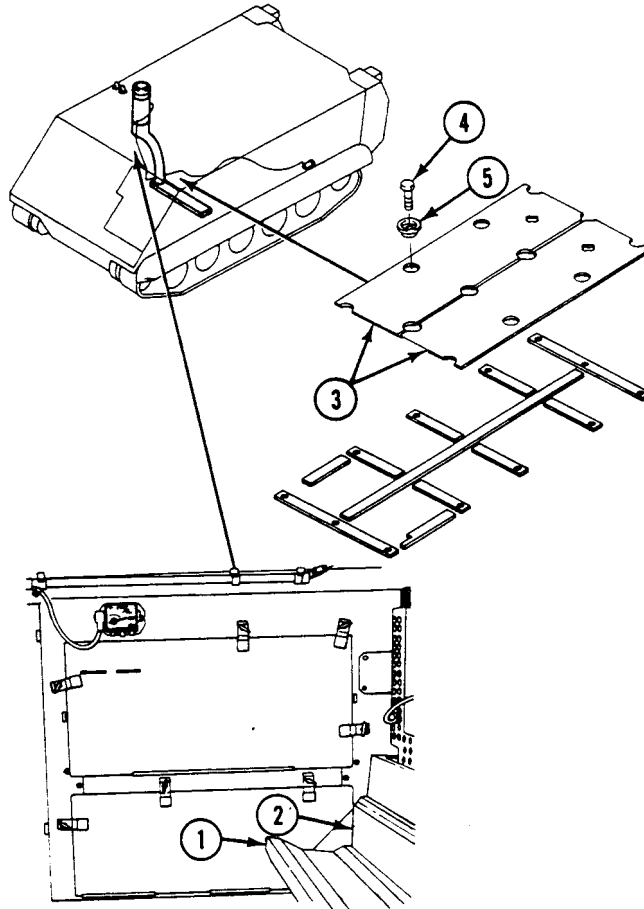

62. Align heater duct (6), three insulation washers (7), and shield (8) with front three holes in floor plates. Secure with three new screws (9) and washers (10) from kit.
63. Secure one nipple (11) to plenum (12) with latch (13).
64. Secure one nipple (11) to duct (6) with latch (13).
65. Secure hose (14) to two nipples (11) with two clamps (15).

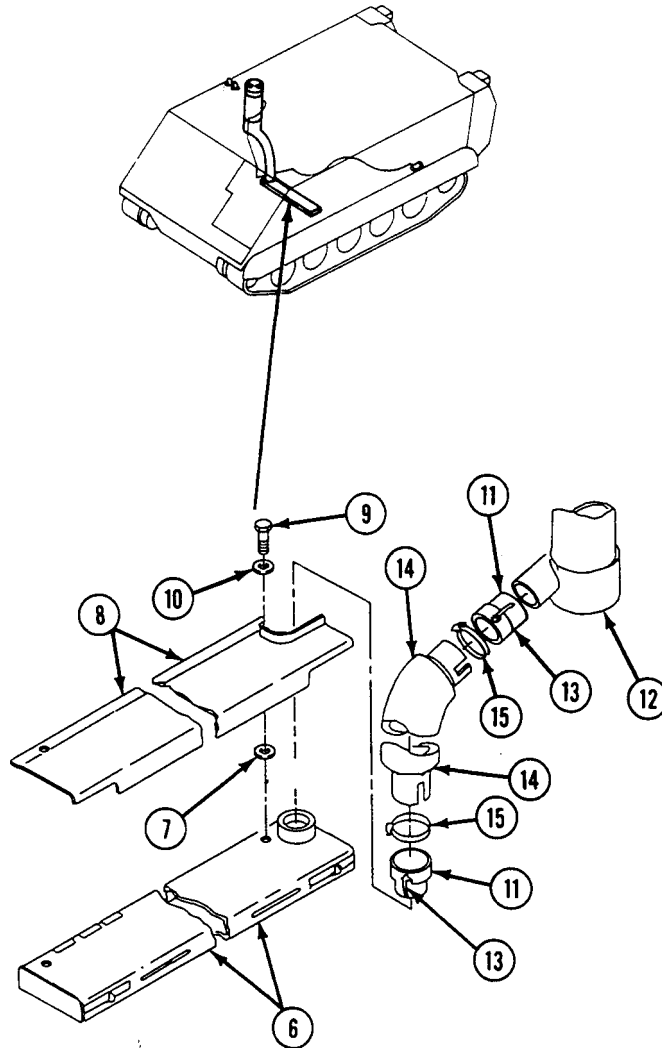

66. Remove two screws (1) and control box (2) from control box case (3).
67. Remove two screws, nuts, and washers supplied with control box case (3). Discard screws, nuts, and washers.
68. Secure control box case (3) to two weldnuts (4) with two lockwashers (5) and screws (6).
69. Secure control box (2) to control box case (3) with two screws (1).
70. Clean small area on hull support next to control box (2) and apply warning decal (see your -20).

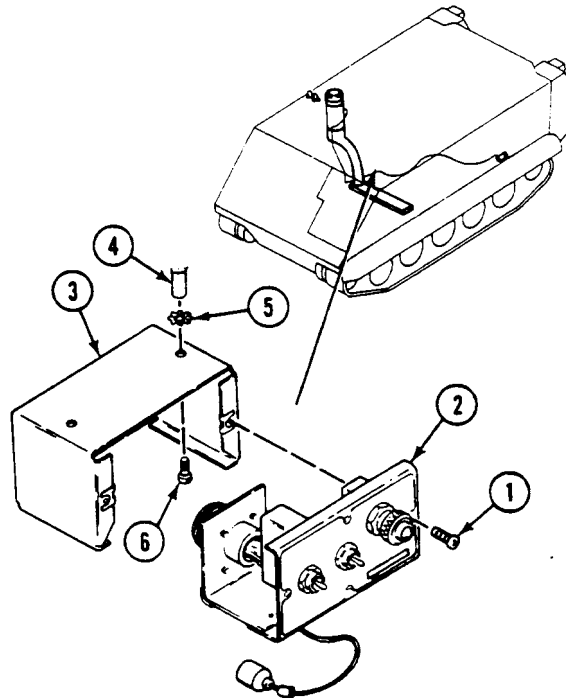

71. Route personnel heater wiring harness (7) through transverse beam from driver's compartment into personnel compartment.
72. Connect personnel heater wiring harness (7) to control box (2).
73. Connect personnel heater wiring harness (7) to personnel heater (8).
74. Install shell (9) and washer (10) on control box lead (11).
75. Connect circuit 400 lead (12) of rear main wiring harness (13) to control box lead (11).
76. Connect circuit 402 lead (14) of rear main wiring harness (13) to fuel pump lead (15) and to connector (16) of personnel heater wiring harness (7).

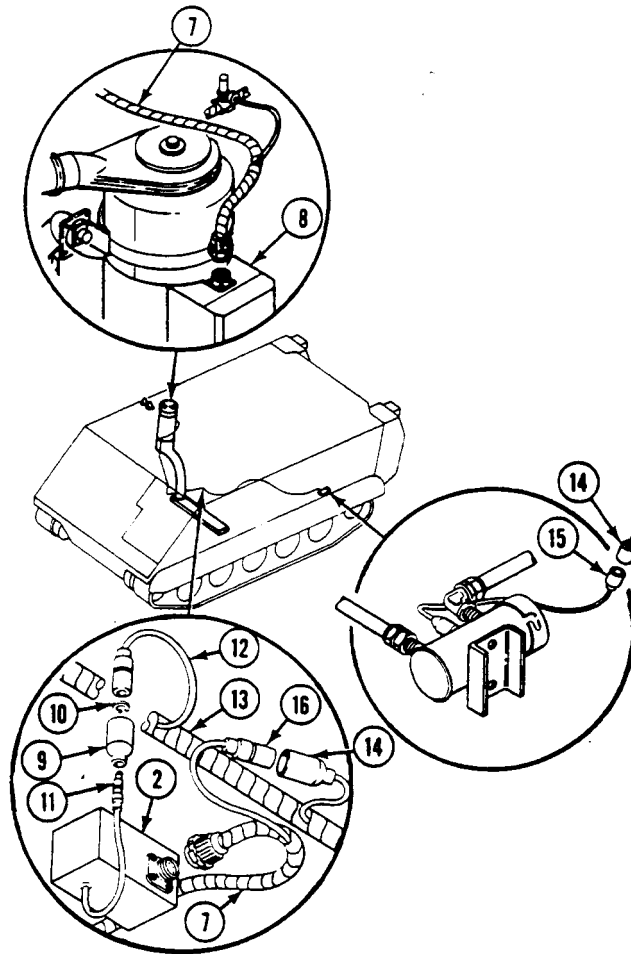

77. Install clamp (1) on battery cable (2), radio cable (3), and personnel heater wiring harness (4).
78. Secure clamp (1) and personnel heater wiring harness ground lead (5) to weldnut (6) with retained screw (7), lockwasher (8), and flat washer (9).

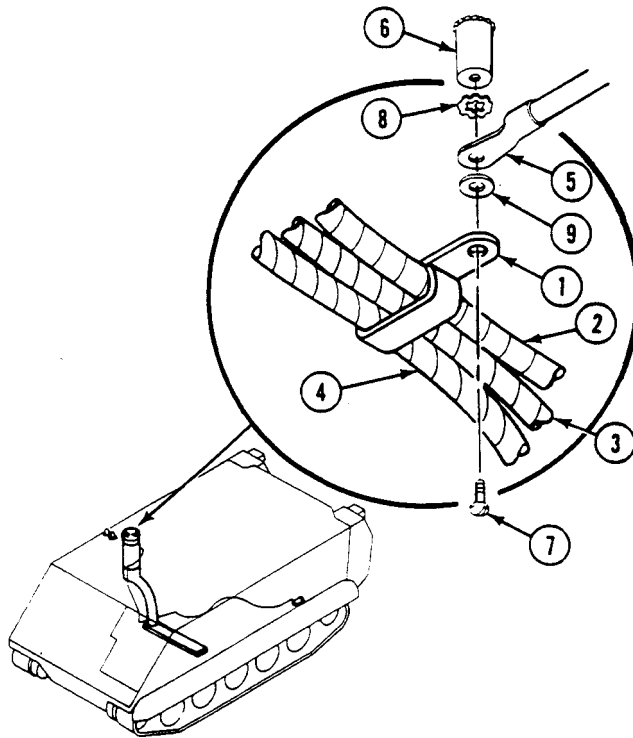

FOLLOW-THROUGH STEPS

1. Open both main fuel tank shutoff valves and heater fuel shutoff valve (see your -10).
2. Bleed air from heater fuel lines (see your -20).
3. Connect battery ground strap (see your -20).
4. Start personnel heater (see your -10). Check heater installation for proper operation and leaks. Turn heater off.
5. Install power plant rear access panels (see your -20).
6. Install rear floor plates (see your -20).
7. Start engine (see your -10).
8. Raise and lock ramp (see your -10).
9. Stop engine (see your -10).

END OF TASK

INSTALL PERSONNEL HEATER KIT (M1064A3 ONLY)

0073 00

THIS WORK PACKAGE COVERS:

Installation (page 0073 00-1).

INITIAL SETUP:

Maintenance Level

Direct Support

Tools and Special Tools

General Mechanic's Tool Kit (WP 0120 00, Item 62)

Materials/Parts

Sealing compound (WP 0122 00, Item 27)

Adhesive primer (WP 0122 00, Item 23)

Personnel Heater Kit P/N S7K1421

Personnel Required

Track Vehicle Repairer 63H10

References

See your -10

See your -20

Equipment Condition

Ramp lowered (see your -10)

Engine stopped (see your -10)

Carrier blocked (see your -10)

Fire extinguisher removed (see your -20)

Battery ground strap disconnected (see your -20)

Power plant rear access panel removed (see your -20)

Floor plates removed (see your -20)

INSTALLATION

1. Remove six screws (1), two plates (2), and gaskets (3) from top of carrier. Discard screws, plates, and gaskets.
2. Remove locknut (4) and screw (5) from transverse beam. Discard locknut and screw.
3. Remove locknut (6) and screw (7) from power plant compartment bulkhead. Discard locknut and screw.

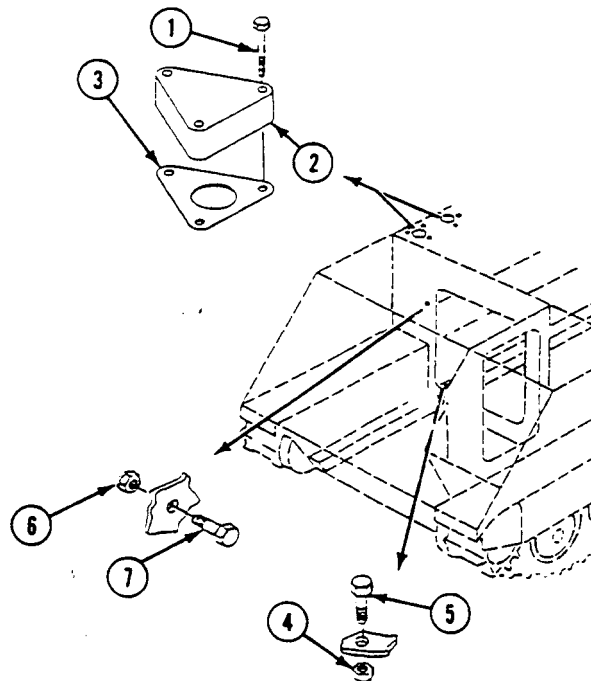

INSTALL PERSONNEL HEATER KIT (M1064A3 ONLY) — Continued

0073 00

4. Install gasket (8) on exhaust elbow (9), and insert elbow through top deck into exhaust pipe (10).
5. Install gasket (11) on air intake elbow (12), and position elbow through top deck opening.
6. Secure exhaust elbow (9) and air intake elbow (12) to top deck with six screws (13).
7. Secure exhaust pipe (10) to exhaust elbow (9) with loop clamp (14).

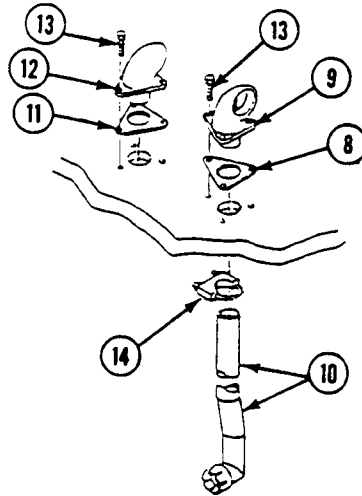

8. Secure plenum (1) to personnel heater (2) with four lockwashers (3) and screws (4).
9. Secure two saddles (5) to two brackets (6) with four screws (7), two lockwashers (8), ground strap (9), and four locknuts (10).
10. Install two clamps (11) on two saddles (5).
11. Install clamp (12) on heater air intake pipe (13) and clamp (14) on heater exhaust port (15).
12. Install elbow (16) on heater air intake pipe (13) and air intake elbow (17).
13. Position heater (2) and shield (18) on two saddles (5), and secure with two clamps (11). Ensure air intake and exhaust fittings are properly aligned.
14. Tighten clamp (14) on heater exhaust port (15) and exhaust pipe in carrier.
15. Tighten clamp (12) on heater air intake pipe (13).

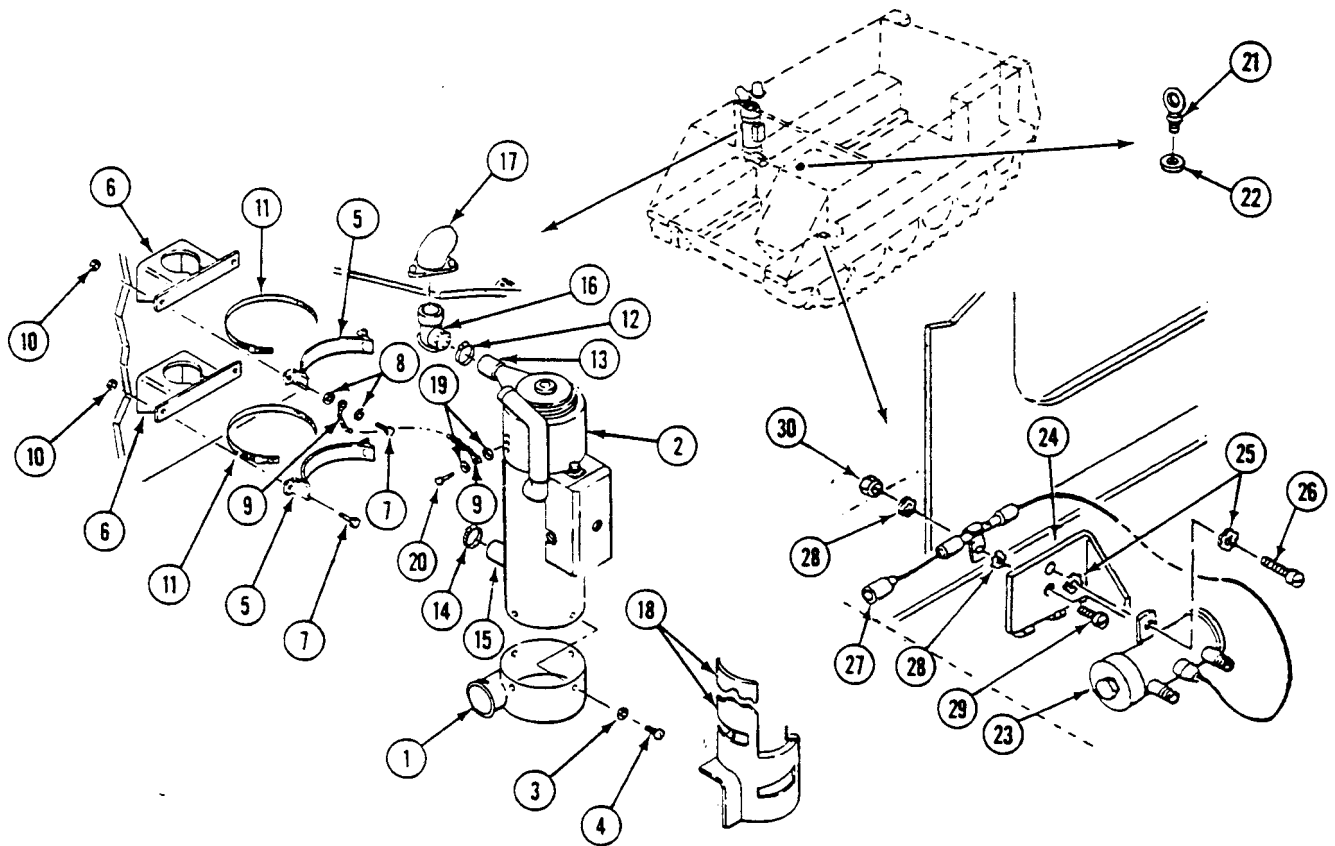

NOTE

For model A20, P/N 5000-30178 heaters, ground strap attaches to top of heater.

NOTE

Perform Step 16 for model A20, P/N 5000-30178 heaters. Perform Step 16.1 for old style heaters.

16. Secure ground strap (9) to heater (2) with one lockwasher (8) and screw (7).

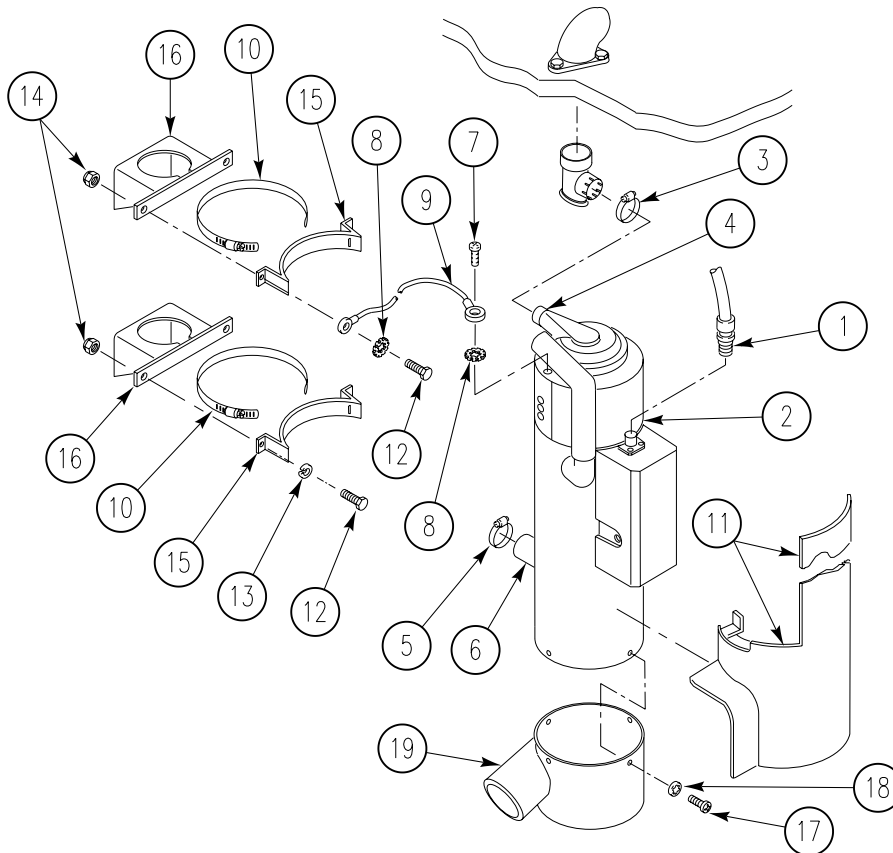

- 16.1. Secure ground strap (9) to heater (2) with two lockwashers (19) and existing screw (20).
17. Discard front three screws (21) and washers (22) removed with floor plates.
18. Secure fuel pump (23) to hull bracket (24) with four lockwashers (25) and two screws (26).

NOTE

Shielded lead must be secure to bracket to ensure complete grounding and proper operations of fuel pump.

19. Secure pump lead (27) to hull bracket (24) with two lockwashers (28), one screw (29), and locknut (30).

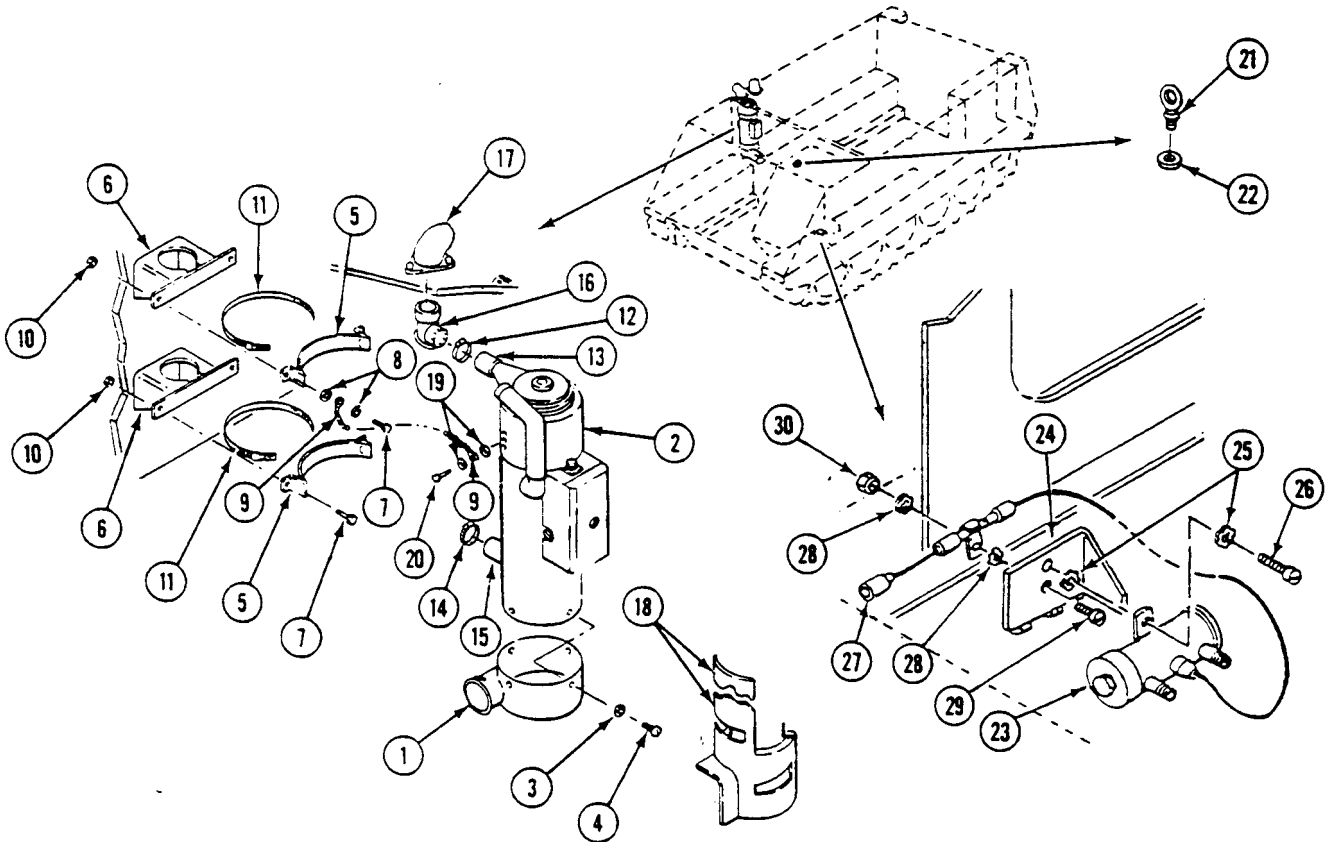

INSTALL PERSONNEL HEATER KIT (M1064A3 ONLY) — Continued**0073 00**

20. Apply a thin coat of adhesive to external tapered threads of fittings.
21. Close heater fuel shutoff valve (1).
22. Remove plug (2) from shutoff valve (1). Discard plug.
23. Install adapter (3) on shutoff valve (1).
24. Install elbow (4) on adapter (3).
25. Install personnel heater fuel hose (5) on elbow (4).

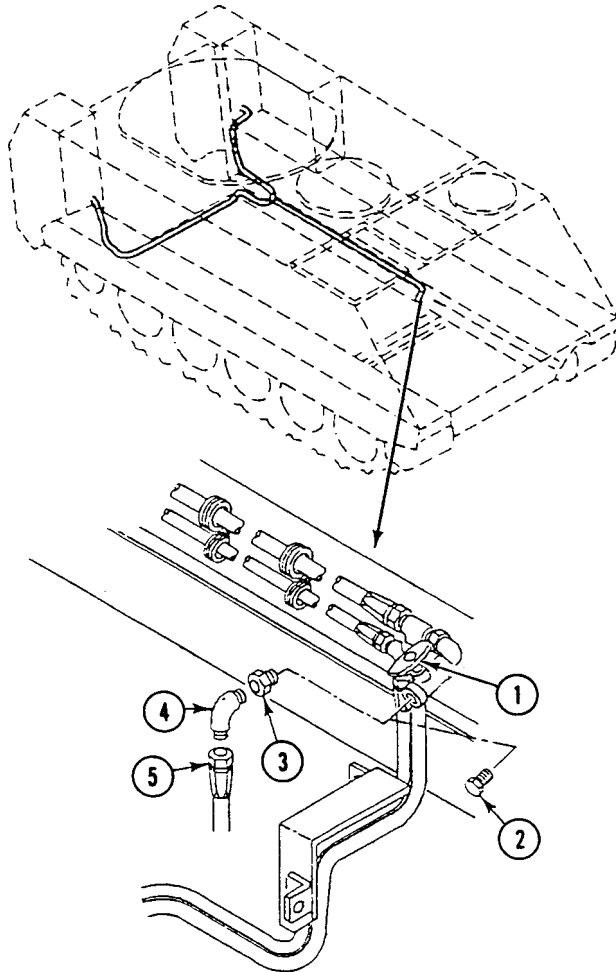

INSTALL PERSONNEL HEATER KIT (M1064A3 ONLY) — Continued

0073 00

26. Remove two screws (6), washers (7), and guard (8) from hull crossmember.
27. Install tee (9) and cap (10) on inlet port of fuel pump (11).
28. Secure heater fuel hose (5) to tee (9) with sleeve (12) and nut (13).

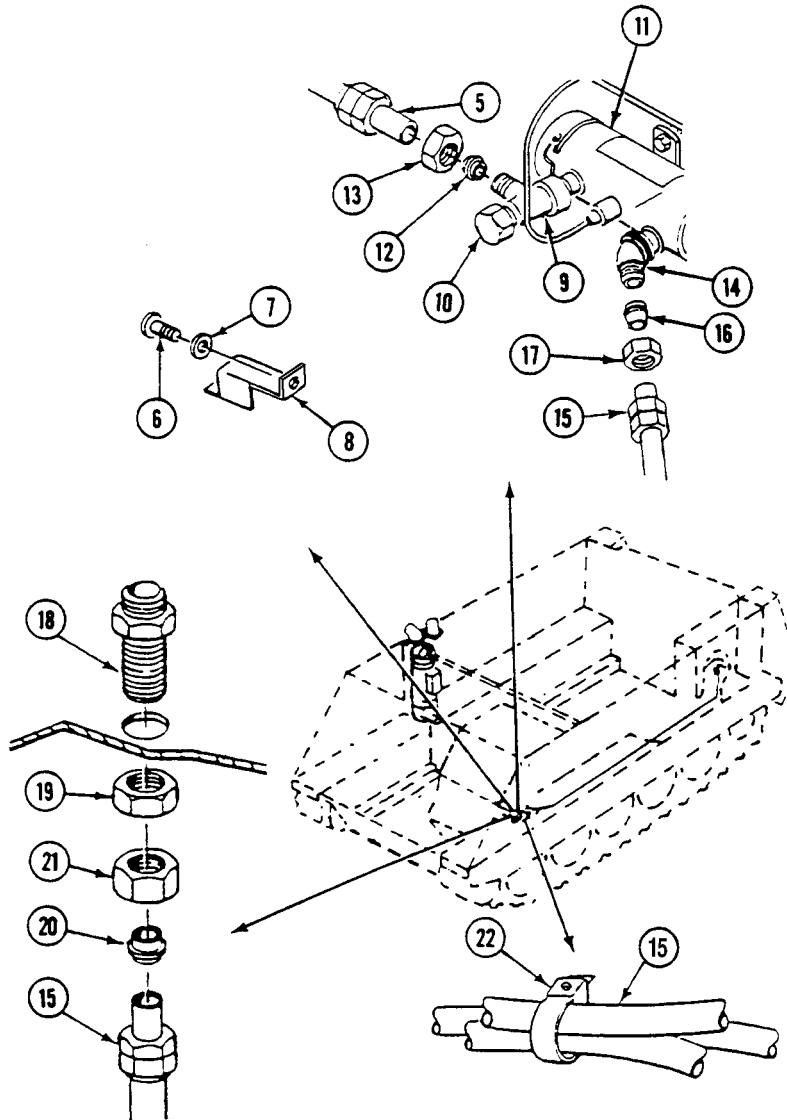

INSTALL PERSONNEL HEATER KIT (M1064A3 ONLY) — Continued

0073 00

29. Secure guard (8) to hull crossmember with two screws (6) and washers (7).
30. Install elbow (14) on outlet port of fuel pump (11).
31. Secure heater fuel hose (15) to elbow (14) with sleeve (16) and nut (17).
32. Secure nipple body (18) to hull with locknut (19).
33. Secure fuel hose (15) to nipple body (18) with sleeve (20) and nut (21).
34. Secure fuel hose (15) to engine fuel hoses with three straps (22).

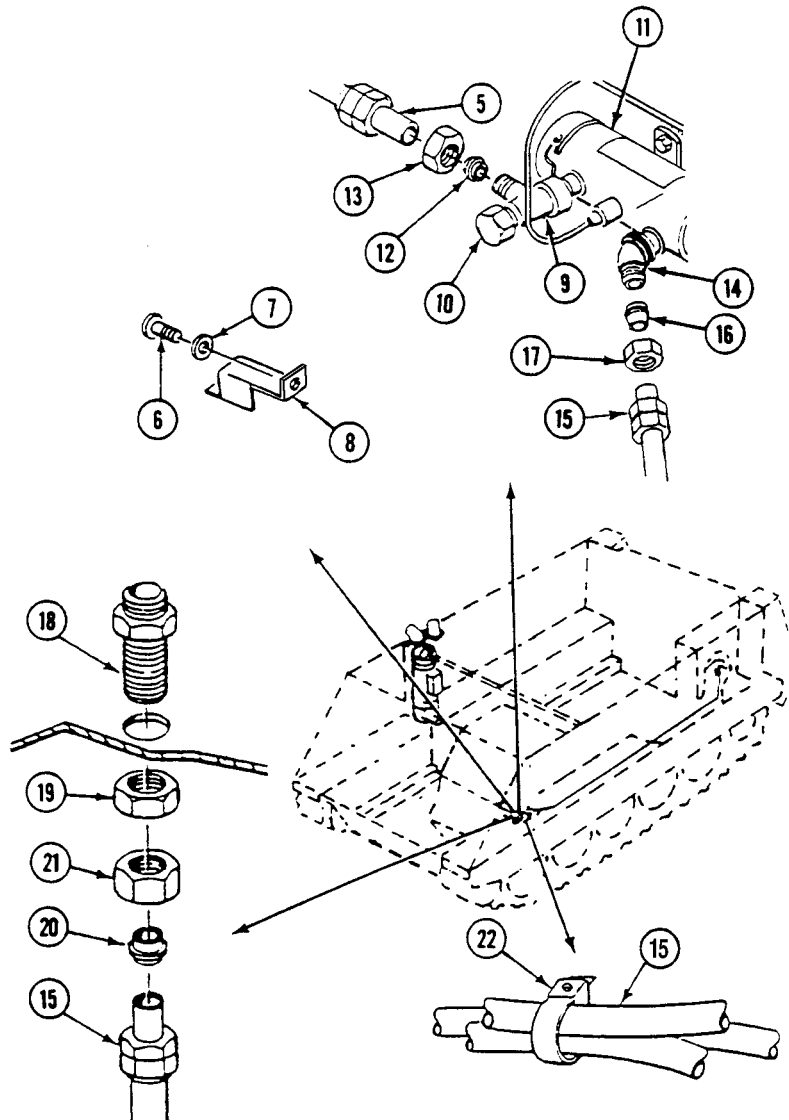

35. Install two elbows (1)(2) on engine compartment bulkhead and secure with two locknuts (3).

NOTE

Replacing a flareless fuel hose or tube assembly may require new mating fittings such as a tee, elbow or adapter.

36. Install two plugs (4) and preformed packings (5) in ports 1 and 4 of fuel filter (6).
 37. Install two elbows (7) (8) and preformed packings (5) in ports 2 and 3 of fuel filter (6).

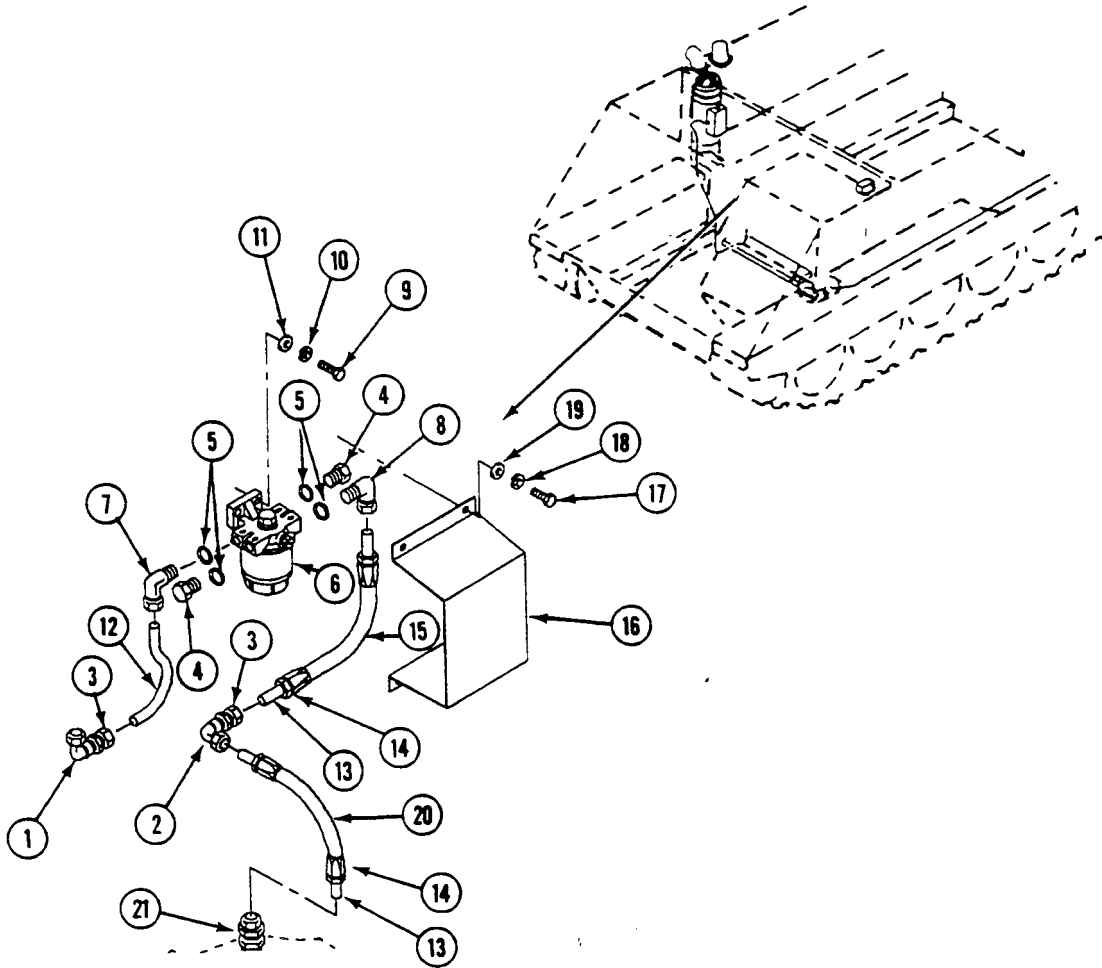

38. Position fuel filter (6) on sponson and secure with two screws (9), lockwashers (10), and washers (11).
39. Connect tube (12) to elbow (1) and elbow (7) with two sleeves (13) and nuts (14).
40. Connect hose (15) to elbow (2) and elbow (8) with two sleeves (13) and nuts (14).
41. Position shield (16) on sponson and secure with four screws (17), lockwashers (18) and washers (19).
42. Secure hose (20) to elbow (2) and nipple body (21) with two sleeves (13) and nuts (14).

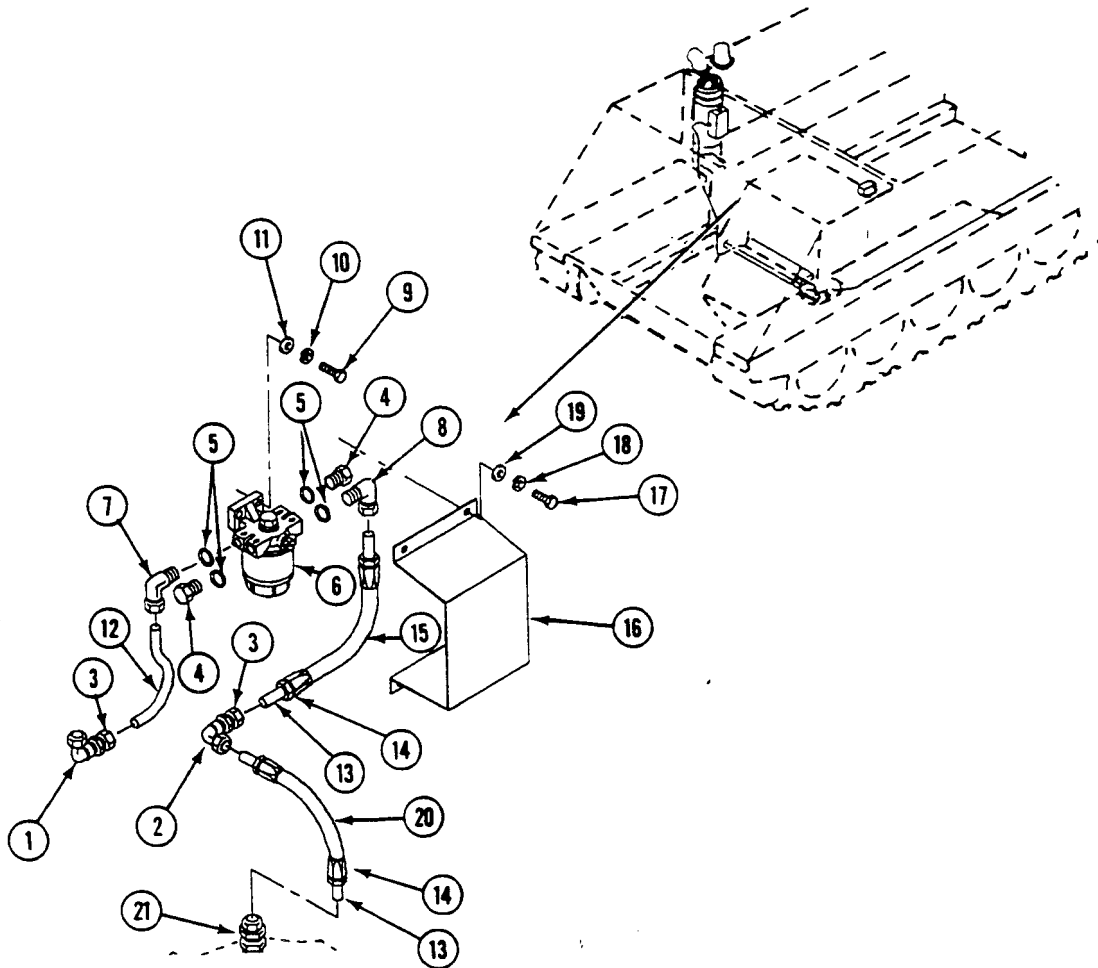

INSTALL PERSONNEL HEATER KIT (M1064A3 ONLY) — Continued

0073 00

43. Secure elbow (1) to power plant bulkhead with locknut (2).
44. Secure tube (3) to elbow (1) and elbow (4) with two sleeves (5) and nuts (6).
45. Secure tube (3) to weldnut (7) with clamp (8) and screw (9).
46. Install nipple (10) in personnel heater (11).

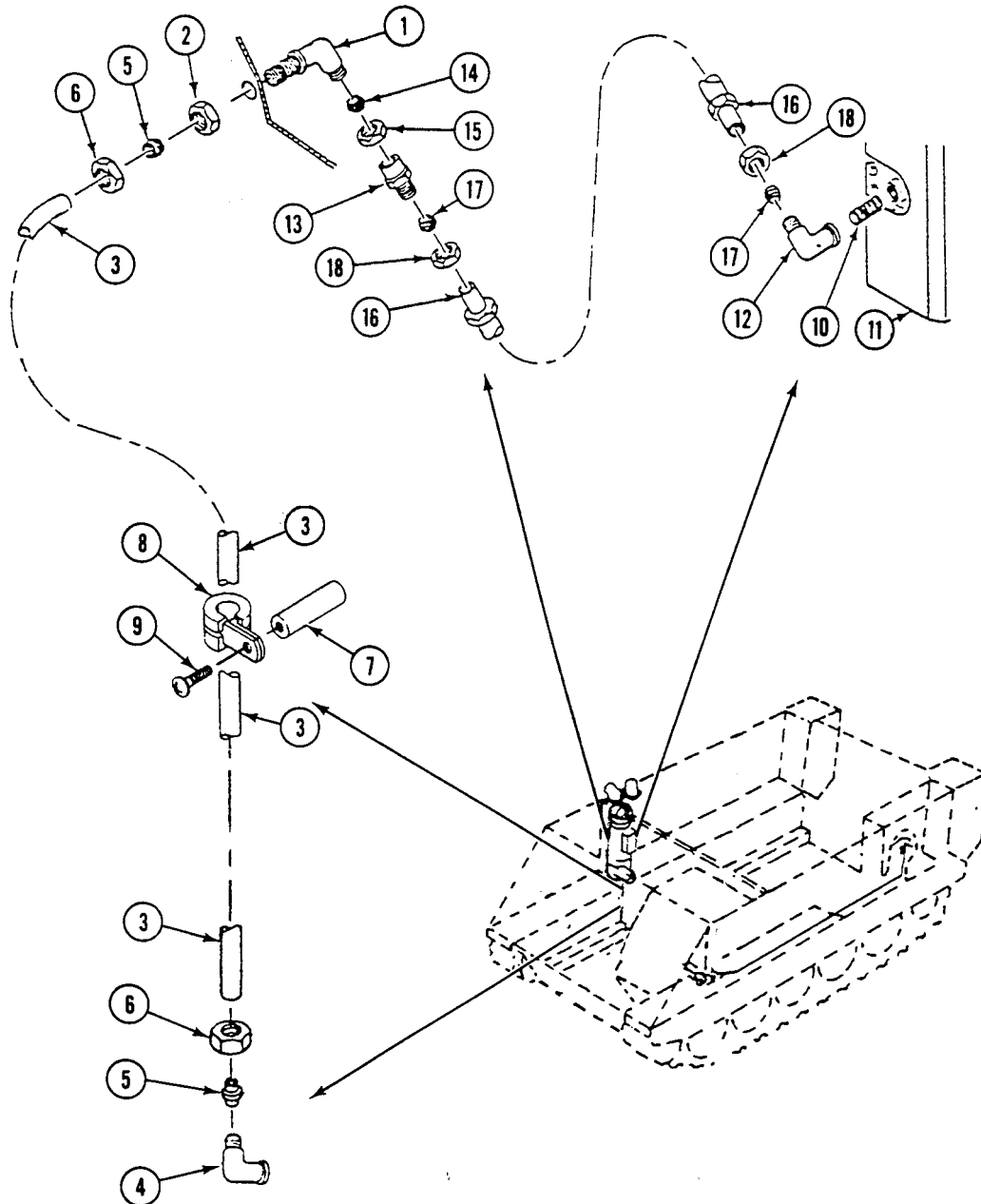

INSTALL PERSONNEL HEATER KIT (M1064A3 ONLY) — Continued

0073 00

47. Install elbow (12) on nipple (10).
48. Secure reducer (13) to elbow (1) with sleeve (14) and nut (15).
49. Secure fuel hose (16) to reducer (13) and elbow (12) with two sleeves (17) and nuts (18).

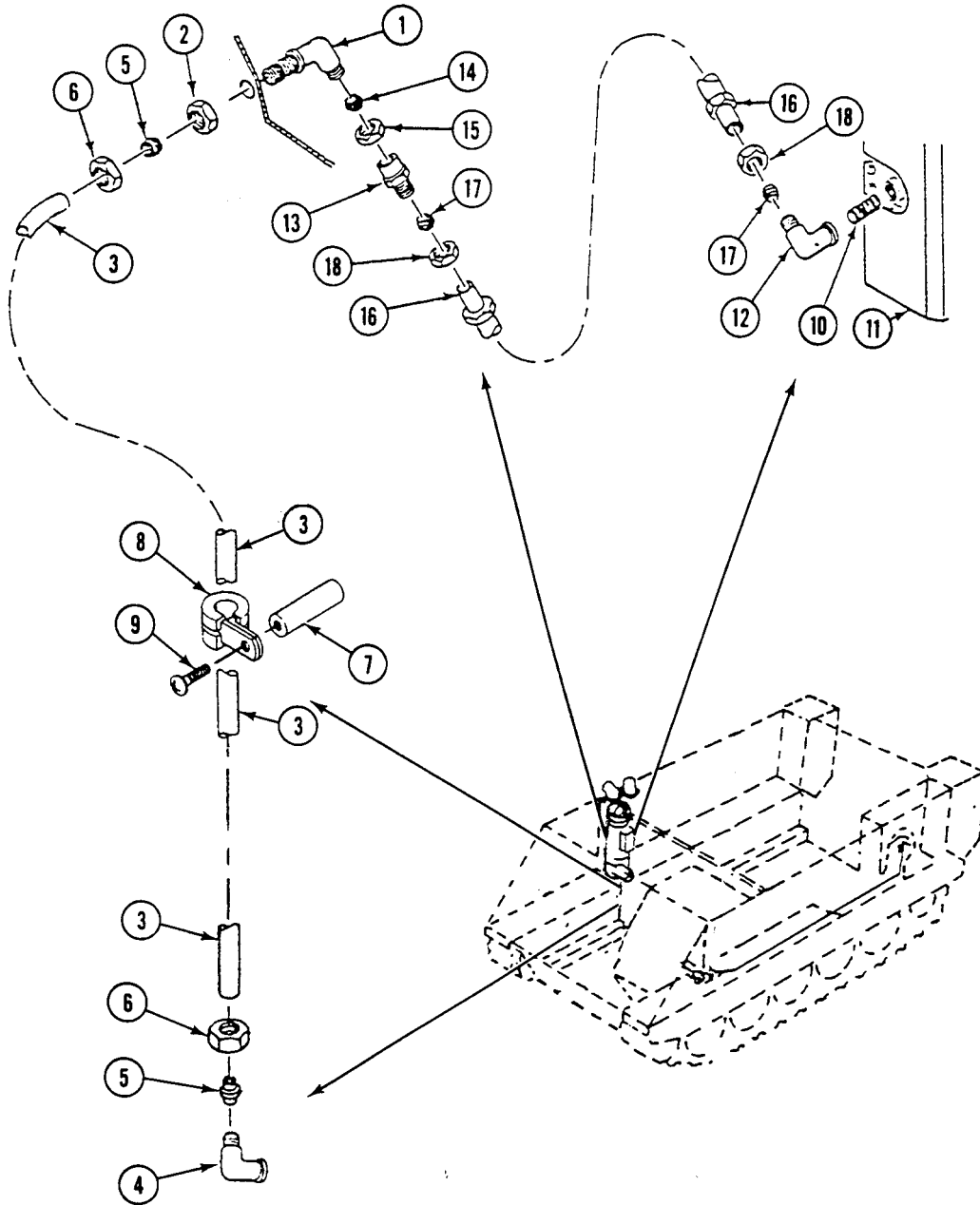

50. Align heater duct (1), three insulator washers (2), and shield (3) with three front holes in front floor plates. Secure with three new screws (4) and washers (5) from kit.
51. Install adapter (6) on heater plenum (7), and adapter (6) on heater duct (1). Secure with two latches (8).
52. Secure hose (9) to two adapters (6) with two clamps (10).

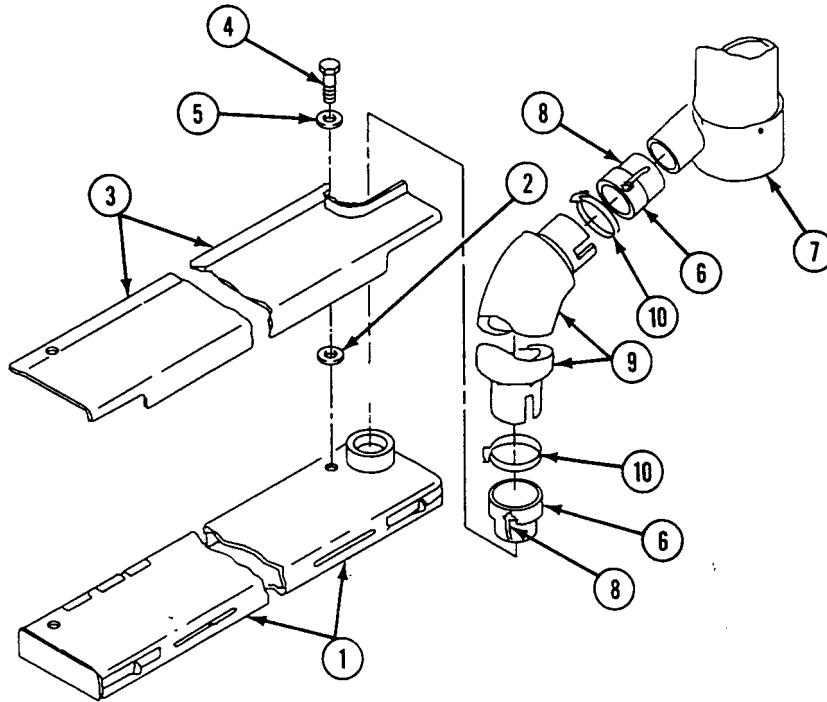

53. Remove two screws (11) and control box (12) from control box case (13).
54. Remove two screws, nuts, and washers supplied with control box case (13). Discard screws, nuts, and washers.
55. Secure control box case (13) to two weldnuts (14) with two lockwashers (15) and screws (16).
56. Secure control box (12) to control box case (13) with two screws (11).
57. Clean small area on transverse beam next to control box (12) and apply warning decal (see your -20).

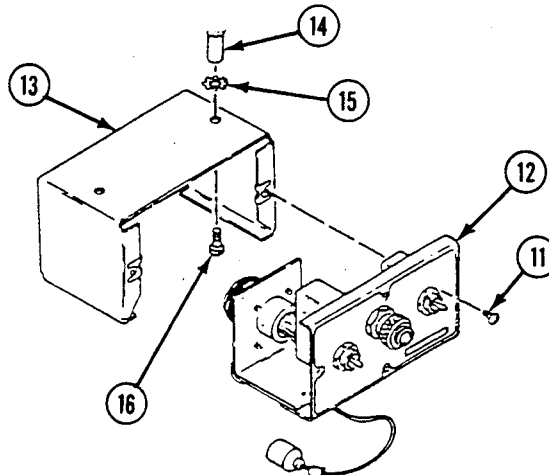

INSTALL PERSONNEL HEATER KIT (M1064A3 ONLY) — Continued

0073 00

58. Route personnel heater wiring harness (1) through transverse beam from driver's compartment into personnel compartment.
59. Connect wiring harness (1) to personnel heater (2).
60. Connect circuit 400 lead (3) of rear main wiring harness (4) to control box lead (5).
61. Connect circuit 402 lead (6) to fuel pump lead (7) and to connector (8) of heater wiring harness (1).

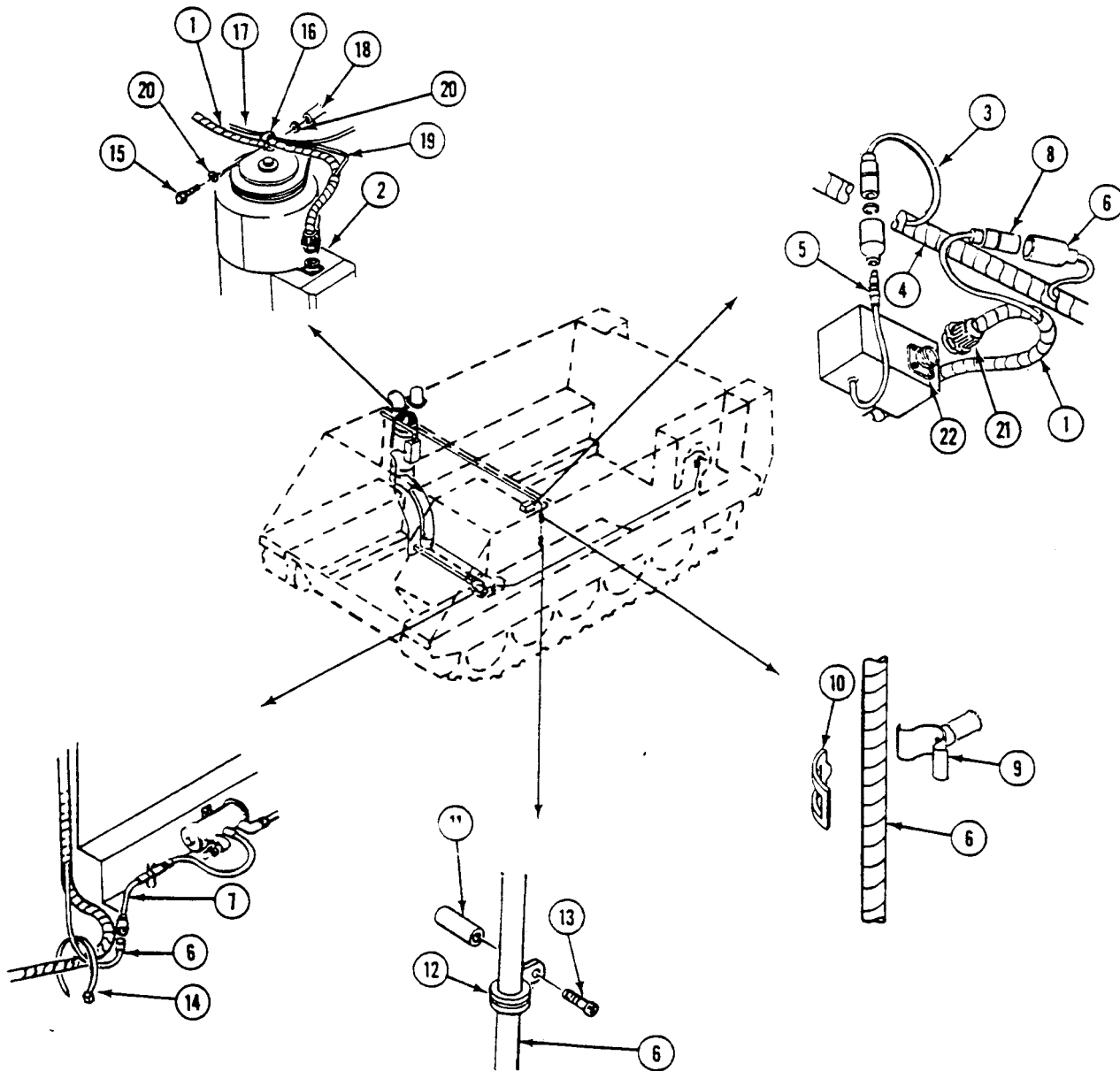

INSTALL PERSONNEL HEATER KIT (M1064A3 ONLY) — Continued

0073 00

62. Secure circuit 402 lead (6) to cradle (9) with cradle clip (10).
63. Secure circuit 402 lead (6) to four weldnuts (11) with four clamps (12), screws (13), and one strap (14).
64. Remove screw (15), securing clamp (16), and dome light lead (17) from weldnut (18).
65. Install clamp (16) on heater wiring harness (1), ground lead (19), and domelight lead (17). Secure clamp to weldnut (18) with screw (15) and two washers (20).
66. Install connector (21) of heater wiring harness (1) on control box connector (22).

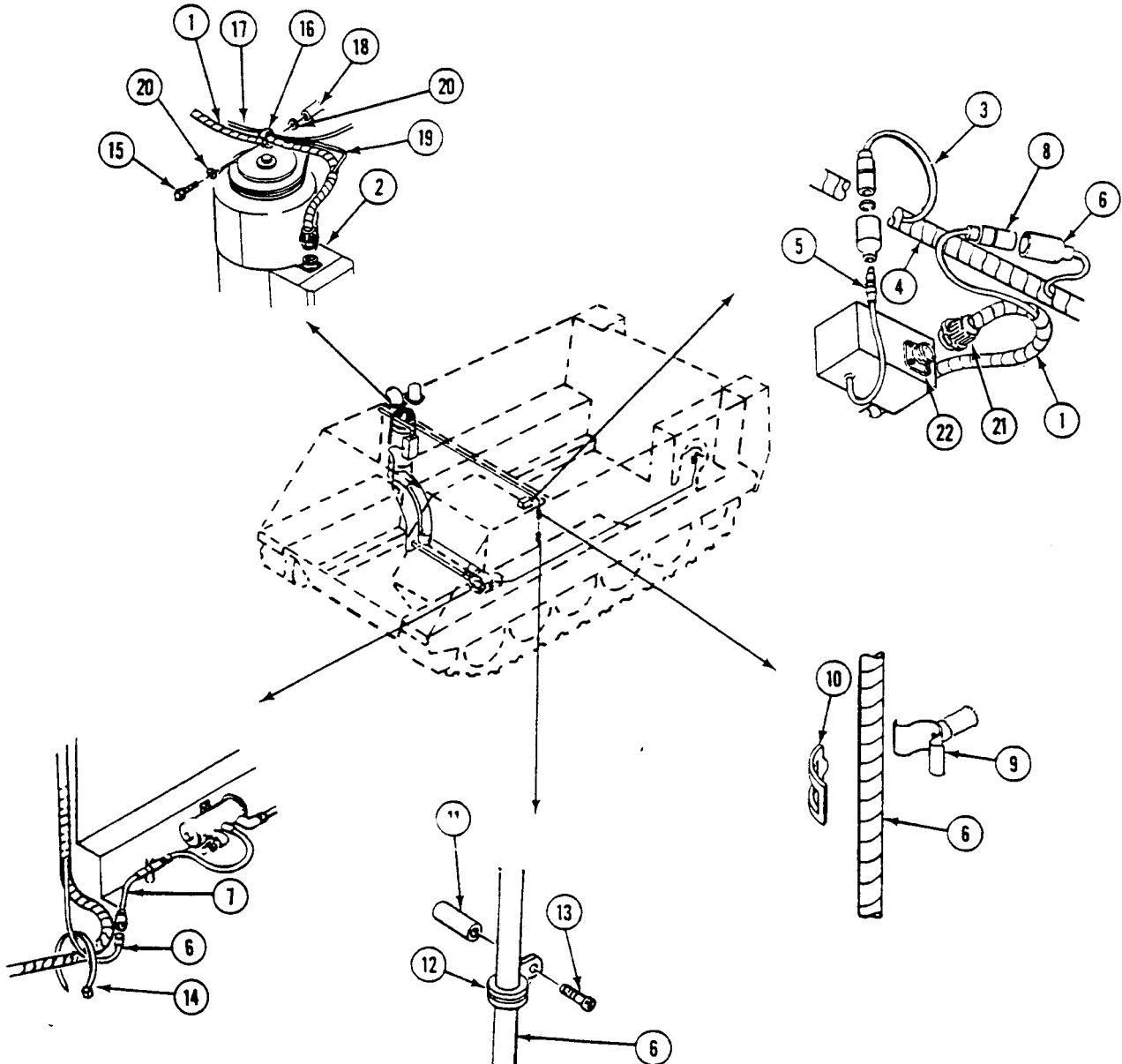

FOLLOW-THROUGH STEPS

1. Open fuel shutoff cock (see your -10). Check for leaks.
2. Connect battery ground lead (see your -20).

INSTALL PERSONNEL HEATER KIT (M1064A3 ONLY) — Continued

0073 00

3. Start personnel heater (see your -10). Check installation for proper operation and leaks.
4. Turn personnel heater OFF (see your -10).
5. Install fire extinguisher (see your -20).
6. Install floor plates (see your -20).
7. Install power plant rear access panel (see your -20).
8. Start engine (see your -10).
9. Raise and lock ramp (see your -10).
10. Stop engine (see your -10).

END OF TASK

REPAIR PERSONNEL HEATER ASSEMBLY

0074 00

THIS WORK PACKAGE COVERS:

Repair or Replacement (page 0074 00-1).

INITIAL SETUP:

Maintenance Level

Direct Support

Personnel Required

Fuel and Elec Sys Rep 63G10

References

TM 9-2540-205-24&P

TM 9-2540-207-14&P

See your -20

Equipment Condition

Personnel heater assembly removed (see your -20)

REPAIR OR REPLACEMENT

1. To repair personnel heater assembly, see TM 9-2540-205-24&P or TM 9-2540-207-14&P.

END OF TASK

INSTALL ENGINE COOLANT HEATER KIT (M113A3 AND M1059A3)

0075 00

THIS WORK PACKAGE COVERS:

Installation (page 0075 00-1).

INITIAL SETUP:

Maintenance Level

Direct Support

Tools and Special Tools

Automotive Fuel and Electrical System Repair Tool Kit
(WP 0120 00, Item 59)

Materials/Parts

Adhesive (WP 0122 00, Item 1)
Cleaning compound (WP 0122 00, Item 8)
Sealing compound (WP 0122 00, Item 27)
Kit P/N 12349820

Personnel Required

Track Vehicle Repairer 63H10

References

See your -10
See your -20

Equipment Condition

Carrier blocked (see your -10)
Battery ground lead disconnected (see your -20)
Driver's power plant access panel removed (see your -20)
Power plant rear access panel removed (see your -20)
Trim vane lowered (see your -10)
Power plant front access door opened (see your -10)
Driver's compartment floor plates removed (see your -20)
Rear and right front floor plates removed (see your -20)
Power plant grille raised (see your -20)
Carrier cooling system drained (see your -20)
Personnel heater kit installed (WP 0072 00)(WP 0073 00)
Power plant removed (see your -20)

INSTALLATION

NOTE

Fuel hoses used on the engine coolant heater installation are the flareless type. If it is necessary to replace hose, the connection fittings must also be replaced.

1. Install mounting bracket (1) on right front sponson. Secure with four screws (2), washers (3), and lockwasher (4).
2. Install coolant pump (5) and ground lead (6) for wiring harness (7) on mounting bracket (1). Secure with clamp (8), two screws (9), three washers (10), lockwasher (11), and two nuts (12).

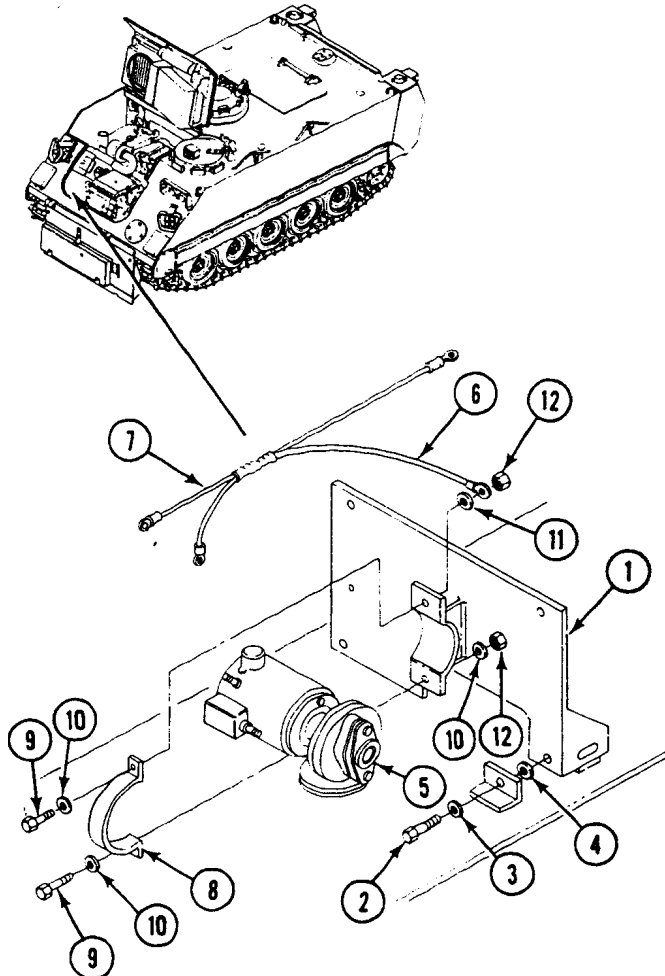

3. Install two mounting saddles (6) on mounting bracket (2). Secure with four screws (3), washers (4), and nuts (5).
4. Install two clamps (1) on two mounting saddles (6).
5. Install coolant heater (7) on two mounting saddles (6). Secure with two clamps (1).

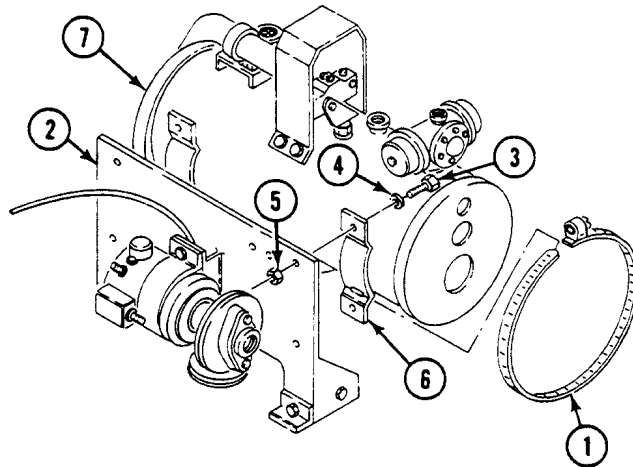

WARNING

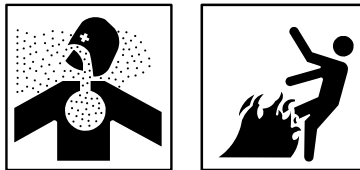

Adhesive, primer, sealant compounds, and isopropyl alcohol are toxic and flammable. These compounds are toxic to eyes, skin, and respiratory tract. Continued exposure can make you dizzy and irritate your eyes and throat.

Always use in well ventilated areas, away from heat, sparks, and flames. Do not breathe fumes. Do not allow into contact with skin and eyes. Use goggles or face shield and protective gloves.

6. Apply sealing compound to external tapered threads of bushings (8)(9)(10), shutoff cocks (11)(12), and three elbows (13)(14)(15). Do not apply sealing compound beyond small end of tapered threads.
7. Install bushing (10), shutoff cock (12), and elbow (15) in pump (16).

8. Install elbow (14) on control valve (17).

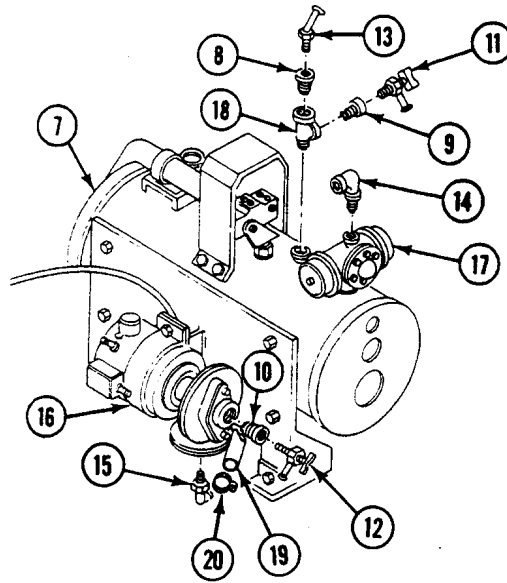

9. Install tee (18) in coolant heater (7).
 10. Install bushing (9) in tee (18).
 11. Install shutoff cock (11) in bushing (9).
 12. Install bushing (8) in tee (18).
 13. Install elbow (13) in bushing (8).
 14. Install hose (19) and clamp (20) on elbow (15).

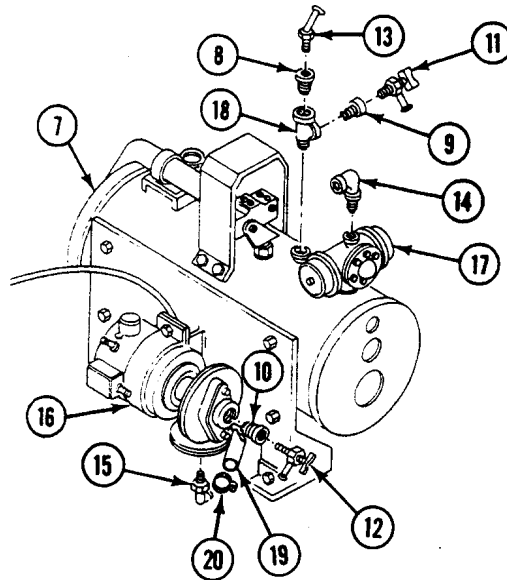

15. Install elbow (21) in coolant heater (7).
 16. Install hose (22) and clamp (23) on elbow (21). Tighten clamp.
 17. Install hose (24) on elbow (13) and secure with clamp (25).

18. Install hose (26) on shutoff cock (11) and secure with clamp (27).

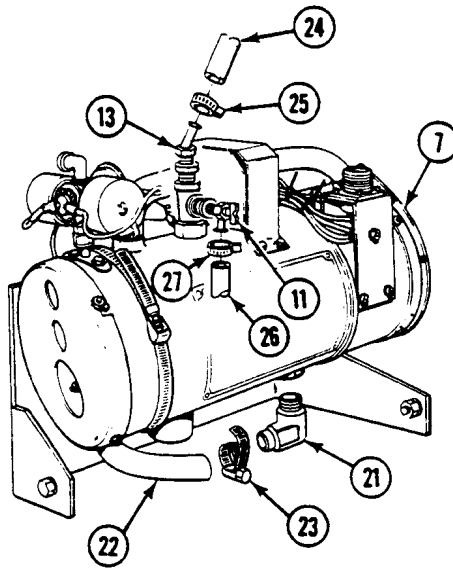

19. Install exhaust pipe (1) on lower tube (2). Secure with clamp (3). Do not tighten clamp.
 20. Install lower tube (2) in coolant heater (4). Secure with clamp (3). Do not tighten clamp.
 21. Tighten two clamps (3).

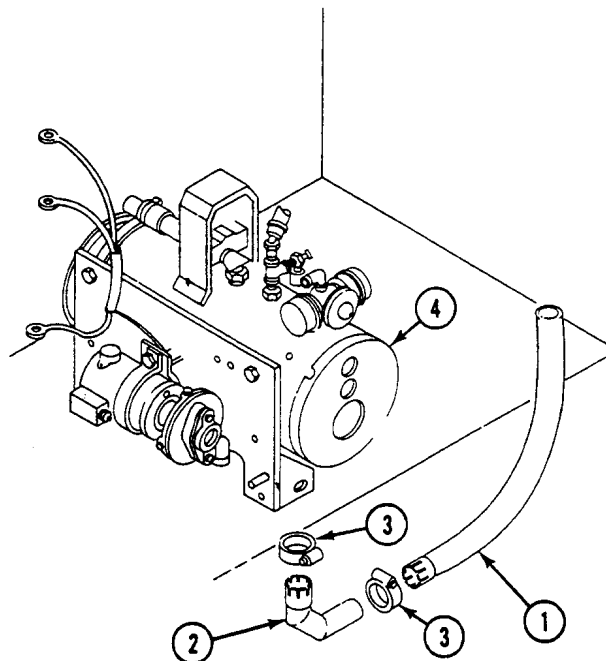

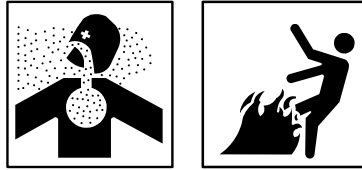
WARNING

Adhesive, primer, sealant compounds, and isopropyl alcohol are toxic and flammable. These compounds are toxic to eyes, skin, and respiratory tract. Continued exposure can make you dizzy and irritate your eyes and throat.

Always use in well ventilated areas, away from heat, sparks, and flames. Do not breathe fumes. Do not allow into contact with skin and eyes. Use goggles or face shield and protective gloves.

22. Apply sealing compound to external threads of elbows (5)(6)(7) and nipple (8).
23. Install filter (9) and spacer (10). Secure with two screws (11), washers (12), lockwashers (13) and nuts (14).
24. Install two elbows (5) and (6) on fuel filter (9).
25. Install nipple (8) on elbow (6).
26. Install fuel shut off valve (15) on nipple (8).
27. Install elbow (7) on fuel shutoff valve (15).
28. Connect hose (16) to elbow (5).

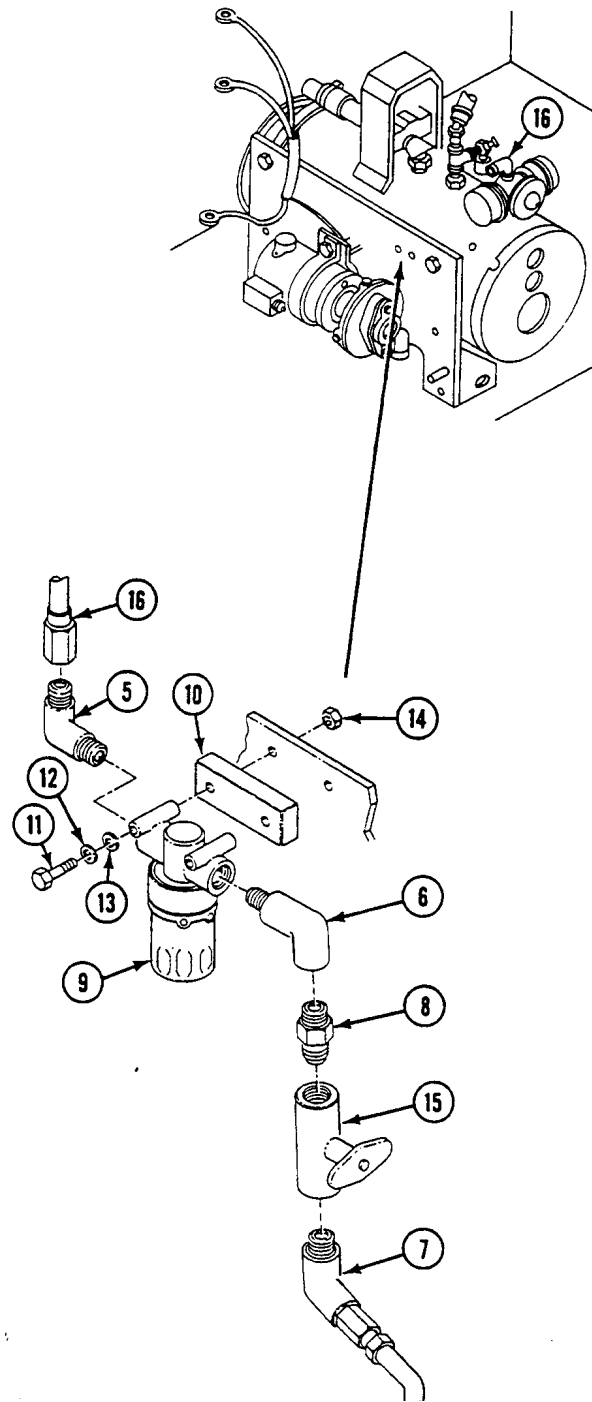

29. Install coolant heater fuel pump (1) on bracket (2). Secure with two screws (3), four lockwashers (4), two washers (5) and two nuts (6).

WARNING

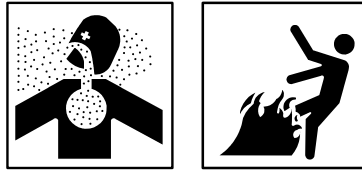

Adhesive, primer, sealant compounds, and isopropyl alcohol are toxic and flammable. These compounds are toxic to eyes, skin, and respiratory tract. Continued exposure can make you dizzy and irritate your eyes and throat.

Always use in well ventilated areas, away from heat, sparks, and flames. Do not breathe fumes. Do not allow into contact with skin and eyes. Use goggles or face shield and protective gloves.

30. Apply sealing compound to external tapered threads of adapter (7), fuel pump (1), and elbow (8). Do not apply sealing compound beyond small end of tapered threads. Do not apply sealing compound on adapter and elbow threads for hose connections.
31. Install adapter (7) on coolant heater fuel pump (1).
32. Install fuel hose (9) on adapter (7).
33. Install coupling (10) on coolant heater fuel pump (1).
34. Install elbow (8) on coupling (10).
35. Install fuel hose (11) on elbow (8).

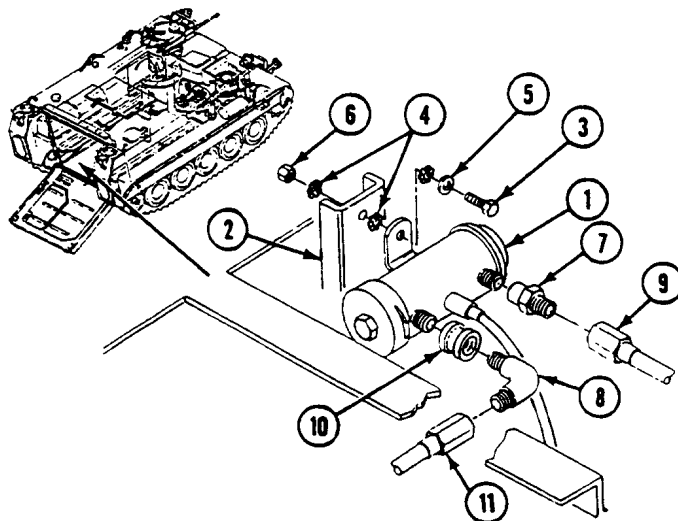

36. Remove and discard cap (12) from personnel heater fuel pump (13).
37. Install fuel hose (14) on personnel heater fuel pump tee (15).
38. Install fuel hose (16) on tee (15).
39. Install coolant heater fuel pump lead (17) and clamp (18) on weldnut (19). Secure with screw (20), washer (21), and two lockwashers (22).
40. Connect circuit 402A lead (23) to coolant heater fuel pump lead (17).

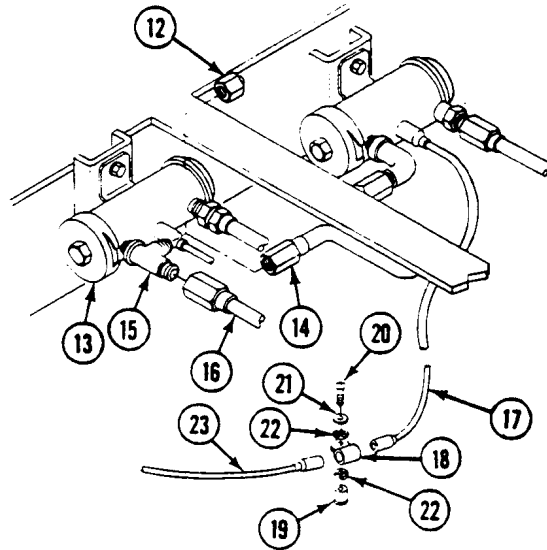

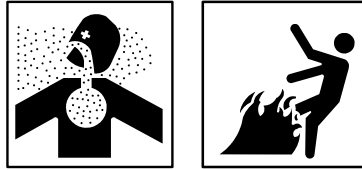
WARNING

Adhesive, primer, sealant compounds, and isopropyl alcohol are toxic and flammable. These compounds are toxic to eyes, skin, and respiratory tract. Continued exposure can make you dizzy and irritate your eyes and throat.

Always use in well ventilated areas, away from heat, sparks, and flames. Do not breathe fumes. Do not allow into contact with skin and eyes. Use goggles or face shield and protective gloves.

41. Apply sealing compound to external tapered threads of elbow (24). Do not apply sealing compound beyond small end of tapered threads.
42. Install elbow (24) and jam nut (25) on bulkhead.
43. Route supply hose (26) through hull openings.
44. Install seven clamps (27) on supply hose (26) with seven screws (28).
45. Connect supply hose (26) to elbow (24).

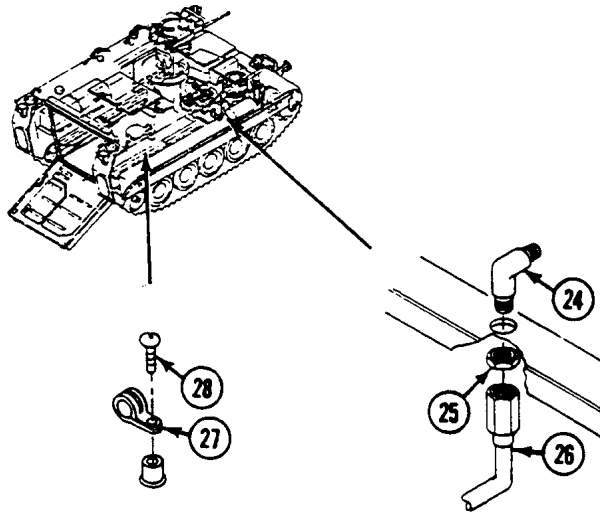

46. Install inlet hose (1) on elbow (2).
47. Align three clamps (3) on hull weldnuts. Secure with three screws (4).
48. Align two clamps (5) with bracket (6). Secure with two screws (7) and nuts (8).
49. Install five clamps (3) and (5) on inlet hose (1).
50. Connect inlet hose (1) to valve elbow (9).

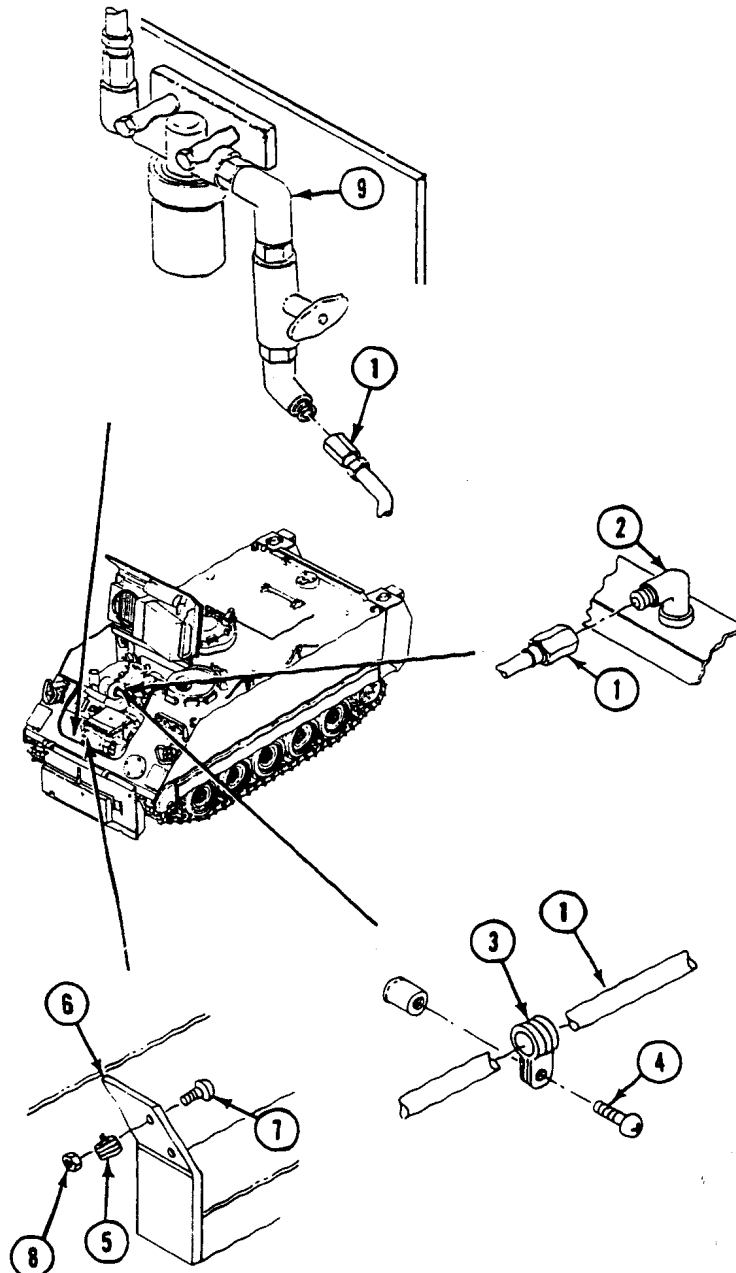

51. Remove batteries and retainers (see your -20).
52. Clean battery box with cleaning compound.
53. Renew adhesive backing on insulation sheets with cleaning compound. Wait 10 to 20 seconds until adhesive becomes tacky.
54. Install insulation sheets (10)(11)(12)(13) and strip (14) in battery box (15).
55. Install insulation sheets (16) on battery box covers (17).

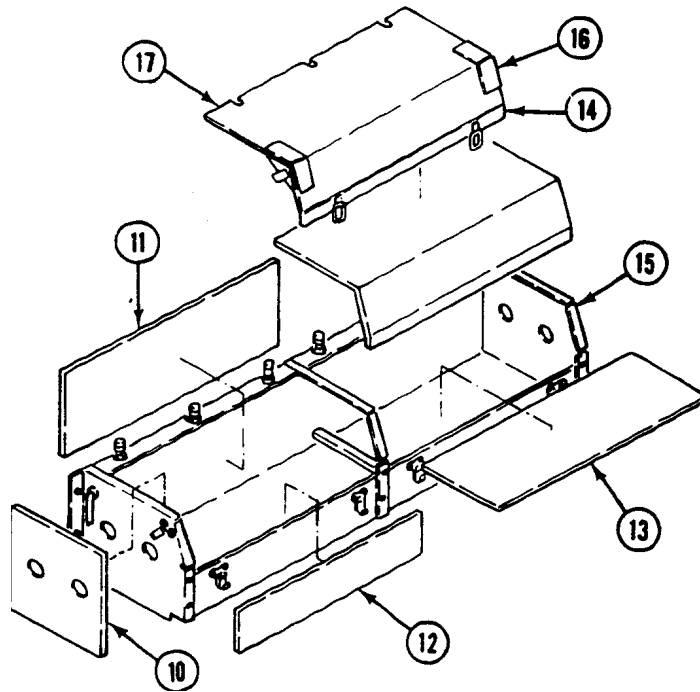

56. Install four grommets (1) and two battery plates (2) in battery box (3).
57. Install four clamps (4) on two battery plates (2).

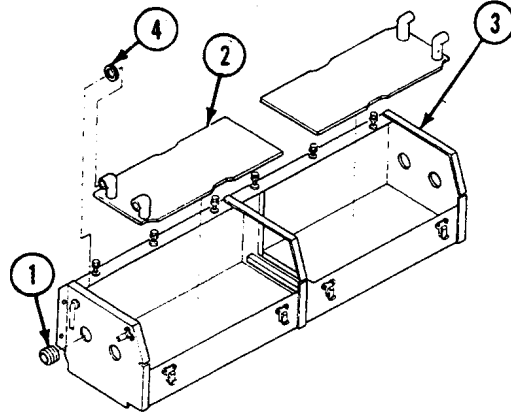

58. Remove two blank grommets (23) from driver's floor plate on older models. On newer models remove two nuts (24), four washers (25), and two screws (26). Discard grommets or nuts, washers, and screws.

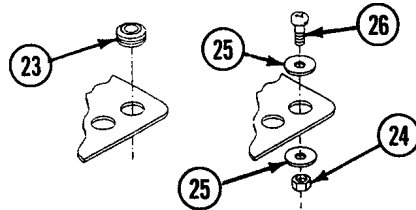

59. Install two elbows (5) in driver's floor plate and secure with two nuts (6).

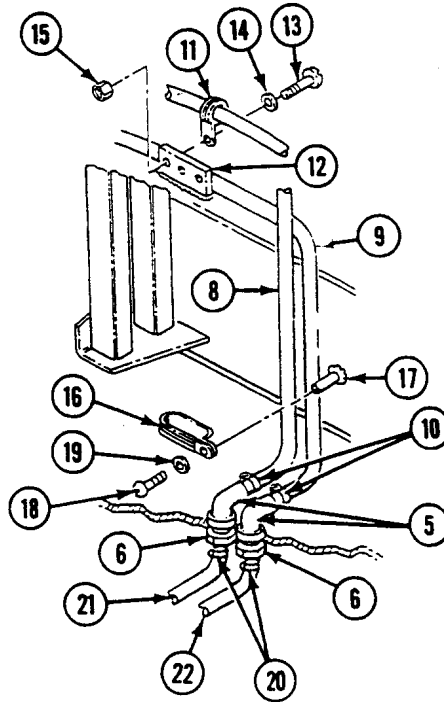

60. Connect battery box hose (7) to battery plates (2). Secure with two clamps (4).
61. Connect one coolant pump hose (8) and one engine hose (9) to battery plates (2). Secure hoses with two clamps (4).

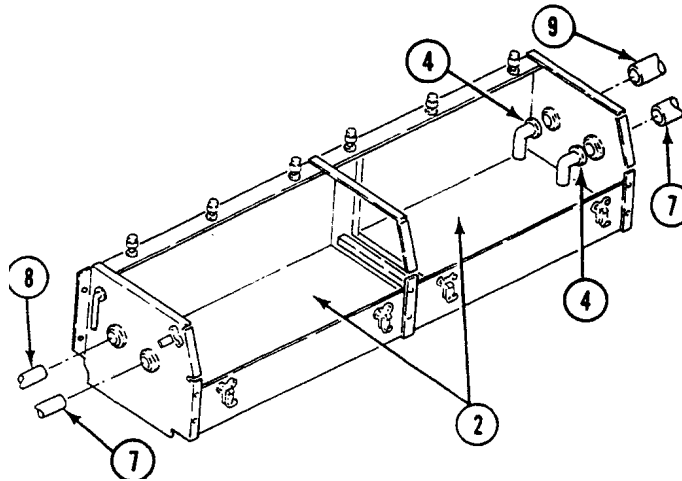

62. Route hoses (8) and (9) along sponson to elbows (5) in floor plate.
63. Install one clamp (10) on each hose (8) and (9). Connect hoses to elbows (5) and secure with clamps (10).
64. Install one clamp (11) on each hose (8) and (9) and secure to seat bracket (12) with two screws (13), washers (14), and nuts (15).

NOTE

Do not kink hoses.

65. Install clamp (16) on hoses (8) and (9) and secure to weldnut (17) with screw (18) and washer (19).
66. Install batteries and retainers (see your -20).
67. Install one clamp (20) each on second coolant pump hose (21) and second engine hose (22). Connect hoses to elbows (5) under driver's floor plate. Tighten clamps.

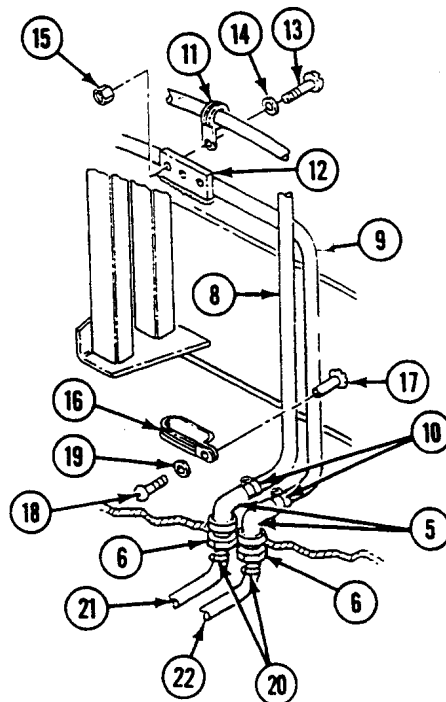

68. Route second coolant pump hose and second engine hose into engine compartment. Leave engine hose for later connection to the engine after the power plant is installed. Route coolant pump hose (1) along front of engine compartment to coolant pump (2).
69. Install clamp (3) on coolant pump hose (1). Connect hose (1) to coolant pump shutoff valve (4). Tighten clamp.

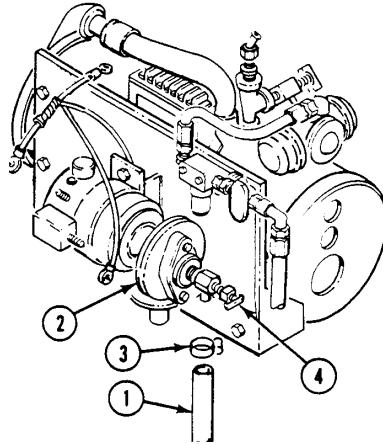

WARNING

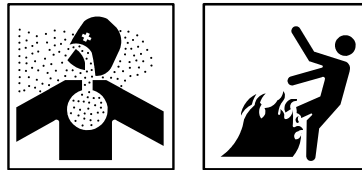

Adhesive, primer, sealant compounds, and isopropyl alcohol are toxic and flammable. These compounds are toxic to eyes, skin, and respiratory tract. Continued exposure can make you dizzy and irritate your eyes and throat.

Always use in well ventilated areas, away from heat, sparks, and flames. Do not breathe fumes.

Do not allow into contact with skin and eyes. Use goggles or face shield and protective gloves.

70. Apply sealing compound to external tapered threads of elbow (5) and adapter (6). Do not apply sealing compound beyond small end of tapered threads.
71. Install elbow (5) in engine block fitting (7). Install adapter (6) in elbow (5).

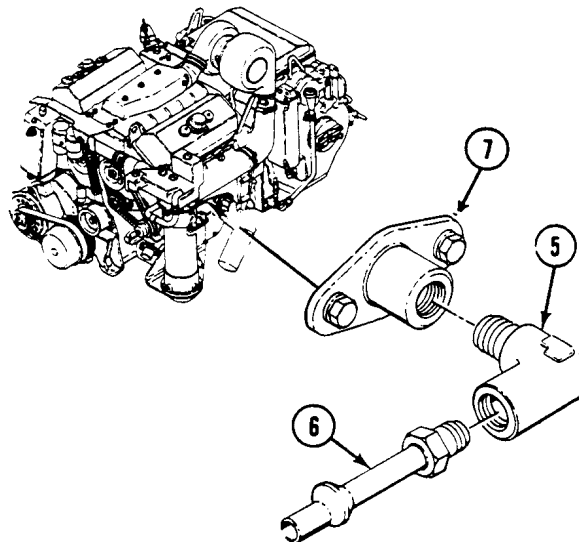

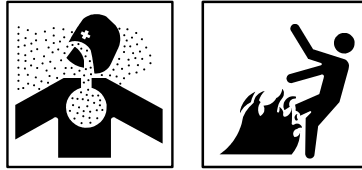
WARNING

Adhesive, primer, sealant compounds, and isopropyl alcohol are toxic and flammable. These compounds are toxic to eyes, skin, and respiratory tract. Continued exposure can make you dizzy and irritate your eyes and throat.

Always use in well ventilated areas, away from heat, sparks, and flames. Do not breathe fumes. Do not allow into contact with skin and eyes. Use goggles or face shield and protective gloves.

72. Apply sealing compound to external threads of elbow (8) and drain cock (9). Do not apply sealing compound beyond small end of tapered threads.
73. Install new gasket (10) and fitting (11) on engine block and secure with two screws (12) and washers (13).
74. Install elbow (8) and drain cock (9) on fitting (11).

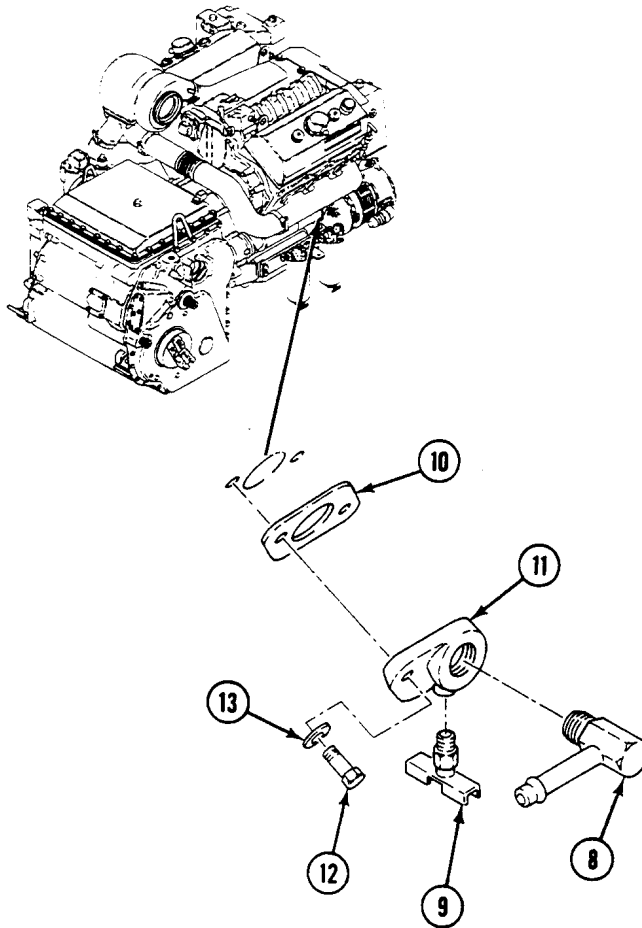

75. Secure ground lead (1) to coolant pump terminal (2) with nut (3).
76. Secure circuit 402B lead (4) to coolant pump terminal (5) with nut (6).
77. Secure circuit 402B lead (4) to terminal No. 4 (7) of terminal strip (8) with screw (9).

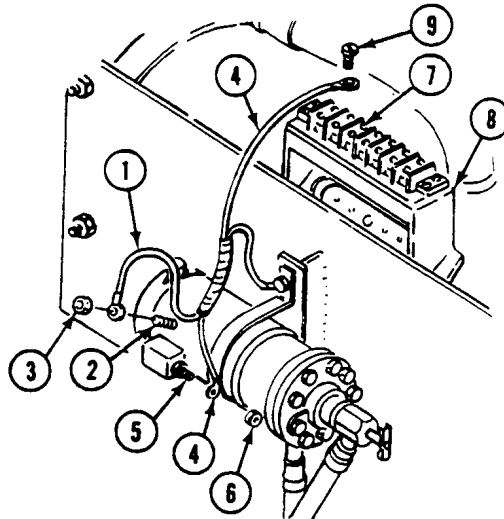

78. Remove four screws (10), four washers (11), and plate (12) from driver's compartment bulkhead. Discard plate.
79. Thread terminal ground lead (13) and coolant heater connector (14) of wiring harness (15) through driver's compartment bulkhead opening.

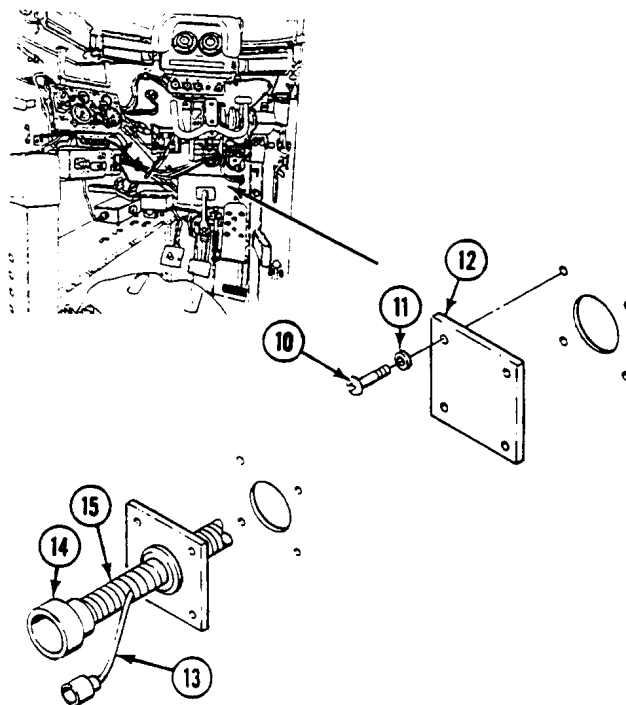

80. Connect coolant heater connector (14) of wiring harness (15) to coolant heater receptacle (16).

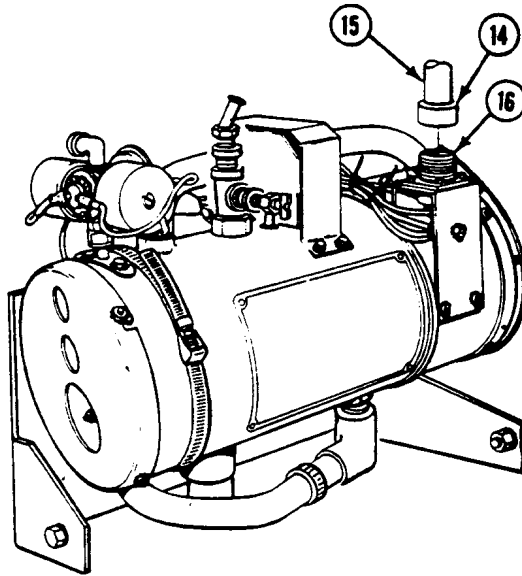

81. Install wiring harness (1) and terminal ground lead (2) to mounting bracket (3). Secure with two screws (4), nuts (5), clamps (6), and lockwashers (7).

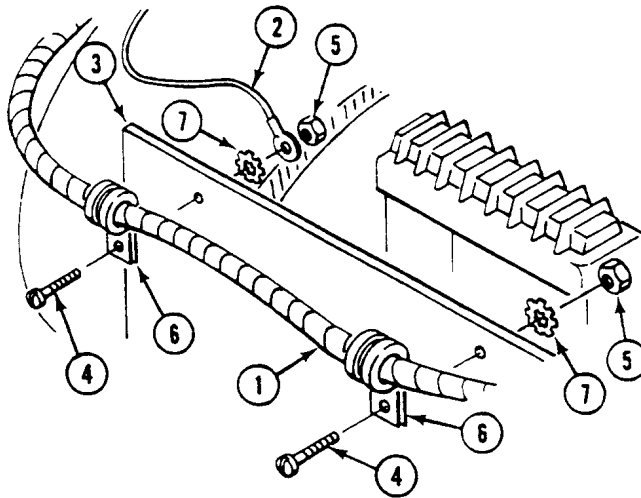

82. Install two tiedown straps (8) around the coolant pump hose (9) and two wiring harnesses (1) and (10).

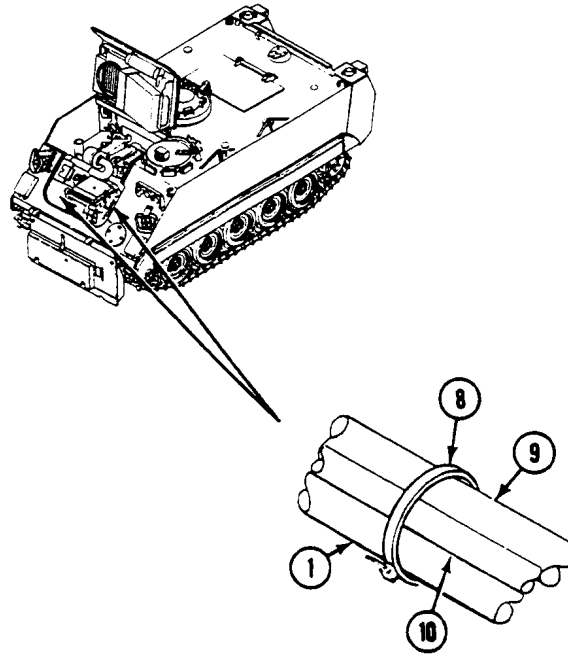

83. Install wiring harness plate (11) to driver's compartment bulkhead. Secure with four screws (12) and washers (13).

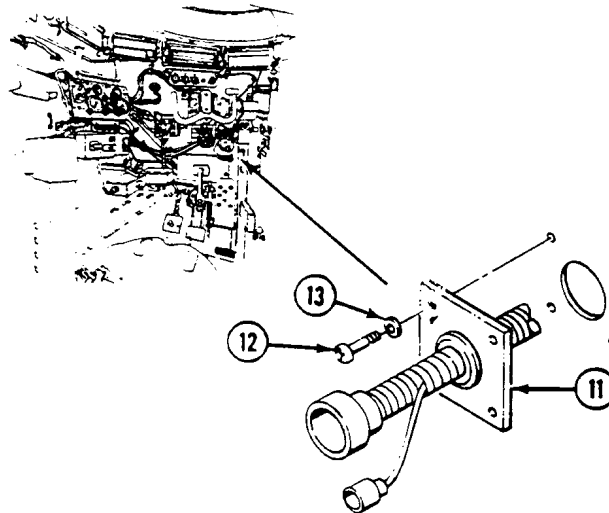

84. Remove two screws (14) and control panel (15) from control box case (16).
85. Remove and discard two screws, nuts, and washers supplied with control box case (16).
86. Install control box case (16) on hull bracket (17). Secure with two screws (18).
87. Install control panel (15) to control box case (16). Secure with two screws (14).
88. Connect circuit 400A lead (19) to control box lead (20).

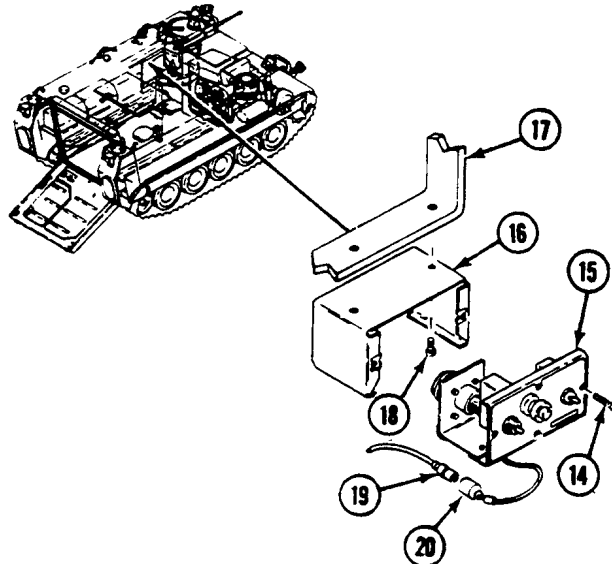

89. Connect control box connector (1) of wiring harness (2) to control box receptacle (3).
90. Connect main wiring harness 402A lead (4) to coolant heater wiring harness lead (5). Secure wiring harness (2) to front main (6) with eight straps (7).

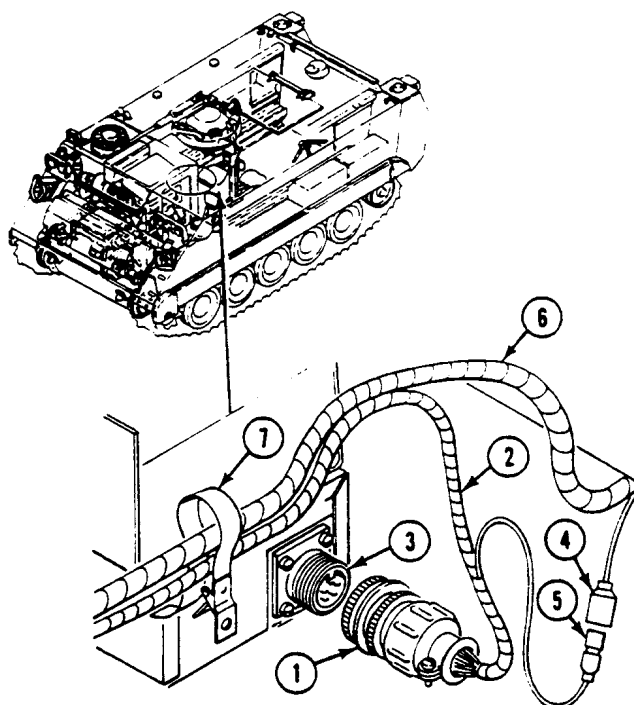

91. Install wiring harness (2) on mounting bracket. Secure with screw (8) and clamp (9).

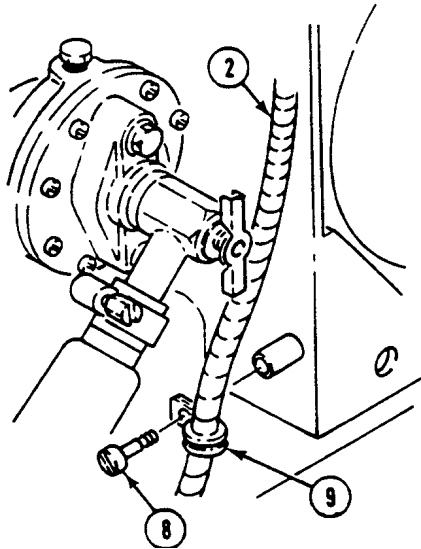

92. Install wiring harness (2) on two weldnuts (10). Secure with two clamps (11) and screws (12).
93. Remove three screws (13) and clamps (14) that secure fuel control cable (15) to three weldnuts (16).
94. Install wiring harness (2) and fuel control cable (15) on three weldnuts (16). Secure with three screws (13), clamps (14), and clamps (17).

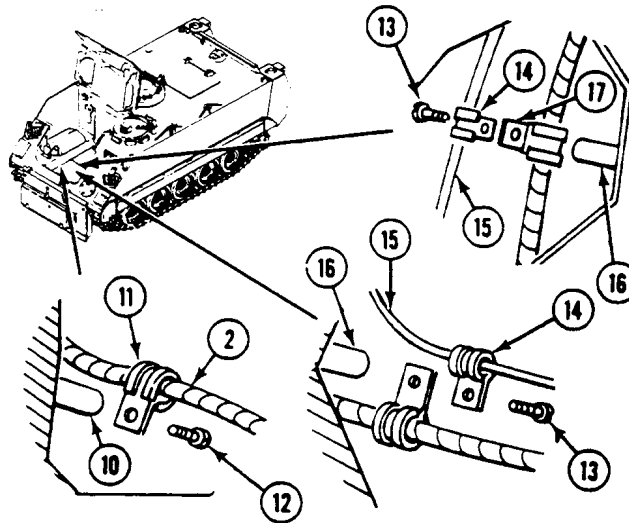

95. Install power plant assembly (see your -20).
96. Connect hose (18) to elbow (19) and secure with clamp (20).

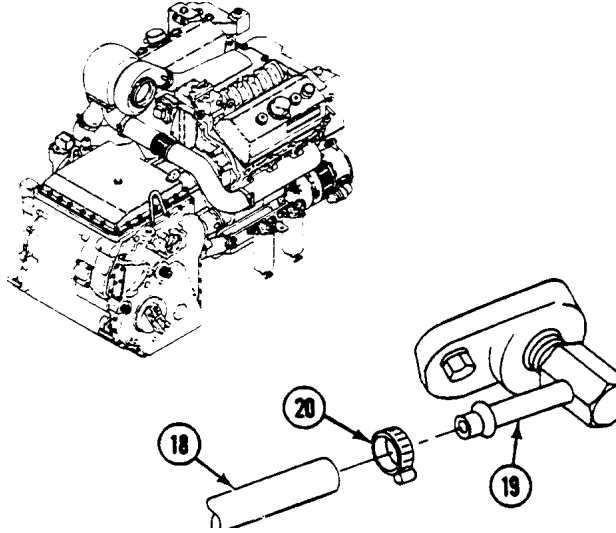

97. Lower power plant grill assembly (see your -20).
98. Remove four screws (1), washers (2), and plate from grille. Discard plate.
99. Install upper tube (3) on exhaust pipe (4). Secure with clamp (5). Do not tighten.
100. Position upper tube (3) and gasket (6) on grille.
101. Secure with four screws (1) and washers (2).
102. Tighten clamp (5).

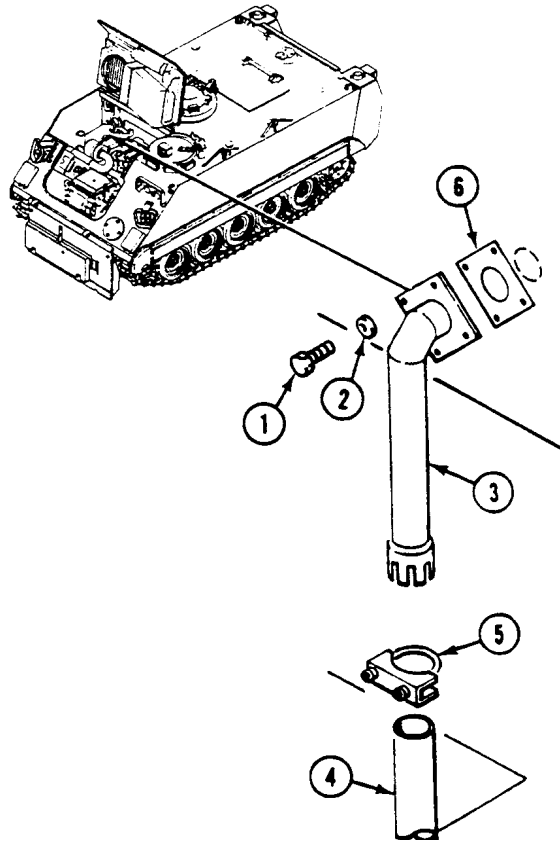

103. Install elbow (7) on auxiliary radiator tank (8).

104. Install hose (9) on elbow (7). Secure with clamp (10).

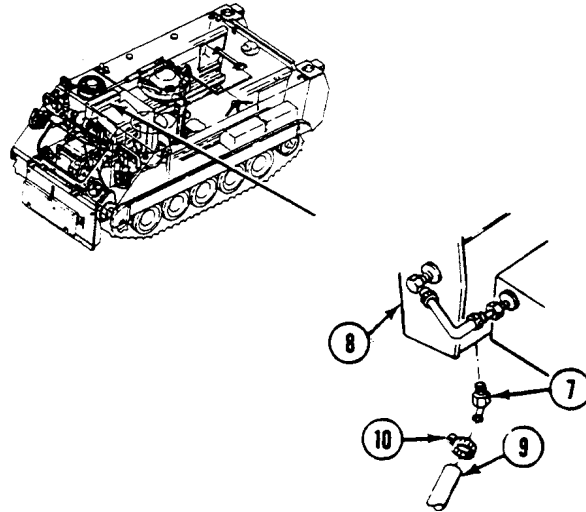

105. Connect hose (11) to adapter (12) and secure with clamp (13).

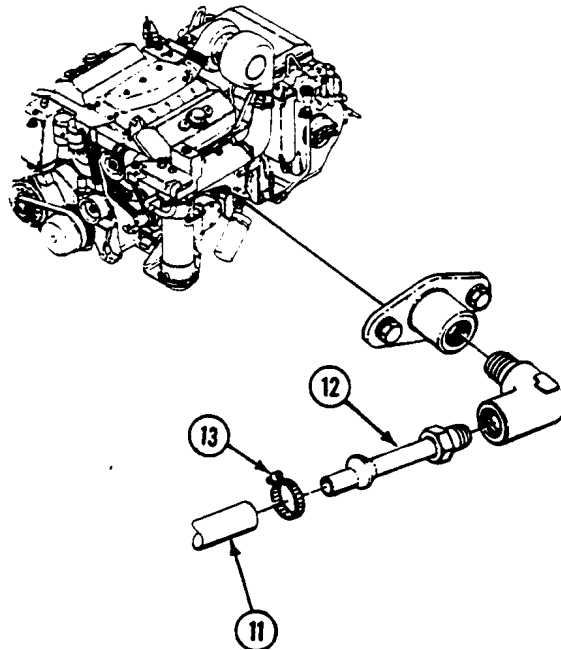

106. Open fuel tank shutoff valves (1).

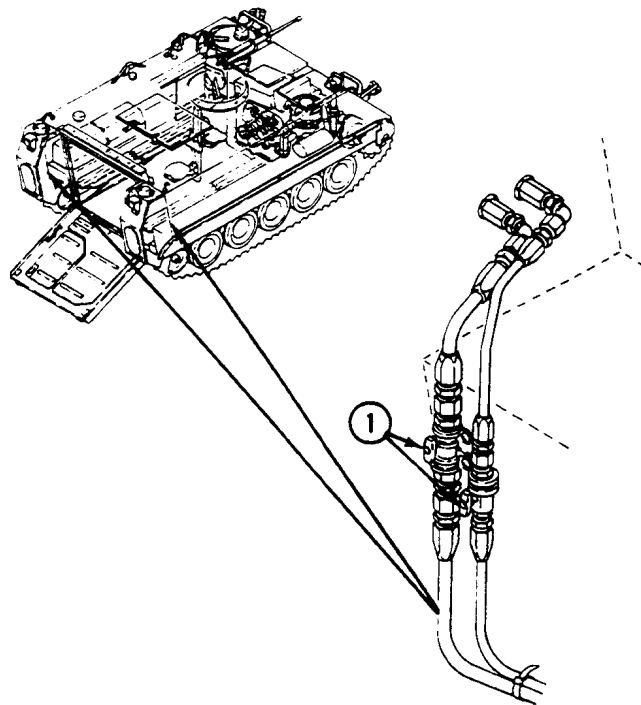

FOLLOW-THROUGH STEPS

1. Lower power plant grille (see your -20).
2. Fill carrier cooling system (see your -20).
3. Connect battery ground lead (see your -20).
4. Bleed coolant heater fuel line (see your -20).
5. Start coolant heater (see your -10). Check that heater works right and does not leak. Turn coolant heater off.
6. Install rear and right front floor plates (see your -20).
7. Install driver's compartment floor plates (see your -20).
8. Install driver's power plant access panel (see your -20).
9. Install power plant rear access panel (see your -20).
10. Close power plant front access door (see your -20).
11. Raise trim vane (see your -10).

END OF TASK

ENGINE COOLANT HEATER DATA

0076 00

THIS WORK PACKAGE COVERS:

The engine coolant heater specifications are listed in the following table.

INITIAL SETUP:

Maintenance Level

Direct Support

INSPECTION-ACCEPTANCE AND REJECTION CRITERIA

EQUIPMENT DATA

Description	Characteristics	Metric Equivalents
Manufacturer	Stewart Warner	
Model	939-J24	
Part Number	11601698	
Heat output:		
Coolant:		
High heat	15,000 Btu/hr	4.4 kW
Low heat	8,000 Btu/hr	2.3 kW
Operating temperature range(surrounding)	-65° to +100°F	-54° to +38°C
Electrical requirements:		
Operating voltage range	20 to 28.5 V	
Amperes draw – max above 70°F (21°C)		
Start	12.0 amp	
Run	1.5 amp	
Amperes draw – max below 70°F (21°C)		
Start	15.0 amp	
Run	3.5 amp	
Performance:		
Fuel	grades DF-1, DF-2, DFA, CIE, and JP-4	
Fuel consumption:		
High heat (normal)	0.026 ± 0.005 lb/min	0.013 ± 0.003 kg/min
Low heat (normal)	0.011 ± 0.003 lb/min	0.006 ± 0.002 kg/min
Fuel pressure (at fuel valve inlet)	3 to 15 psi	21 to 103 kPa
Fuel pump output pressure	3 to 6 psi	21 to 41 kPa
Temperature settings:		
Overheat thermostat (opens)	245°F	118°C
Restriction thermostat setting	160°F	71°C
Dimensions and weight:		
Height	10 in.	25 cm
Length	15-5/16 in.	39 cm
Width	6-3/16 in.	16 cm
Weight	15 lb	7 kg
Coolant pump:		
Manufacturer	MP Pumps, Inc.	
Model	12245	
Part number	10946835	
Electrical requirements:		
Operating voltage range	20 to 28.5 V	
Ampere draw	2.0 amp	
Output	12 to 16 gpm	45 to 61 liters/min
Weight (maximum)	10 lb	5 kg

END OF TASK

FINAL TEST – COOLANT HEATER

0077 00

THIS WORK PACKAGE COVERS:

- Test setup (page 0077 00-1).
- Coolant system (page 0077 00-3).
- Electrical wiring (page 0077 00-4).
- Exhaust collector (page 0077 00-5).
- Testing (page 0077 00-5).
- Burn test (page 0077 00-5).
- Testing restriction and overheat thermostats (page 0077 00-6).

INITIAL SETUP:

Maintenance Level

Direct Support

Tools and Special Tools

Automotive Fuel and Electrical System Repair Tool Kit
(WP 0120 00, Item 59)

Digital Multimeter (WP 0120 00, Item 38)

Materials/Parts

- 24 V dc power source
- 0 to 30 V dc voltmeter
- 0 to 20 amps dc ammeter
- Suitable rack or cradle
- Control box
- Thermometer
- Suitable coolant container (5 gallon minimum)

Suitable exhaust hose (10 foot maximum)

Fuel filter

Fuel pump

Fuel source

Stopwatch

Personnel Required

Fuel and Elec Sys Rep 63G10

References

See your -10

See your -20

Equipment Condition

Coolant heater removed from carrier (see your -20)

TEST AND INSPECTION

TEST SETUP

CAUTION

Test setup must be wired for negative ground.

1. After overhaul of coolant heater, conduct a final test before installation, to make sure heater will work right. The suggested typical test setup is shown.

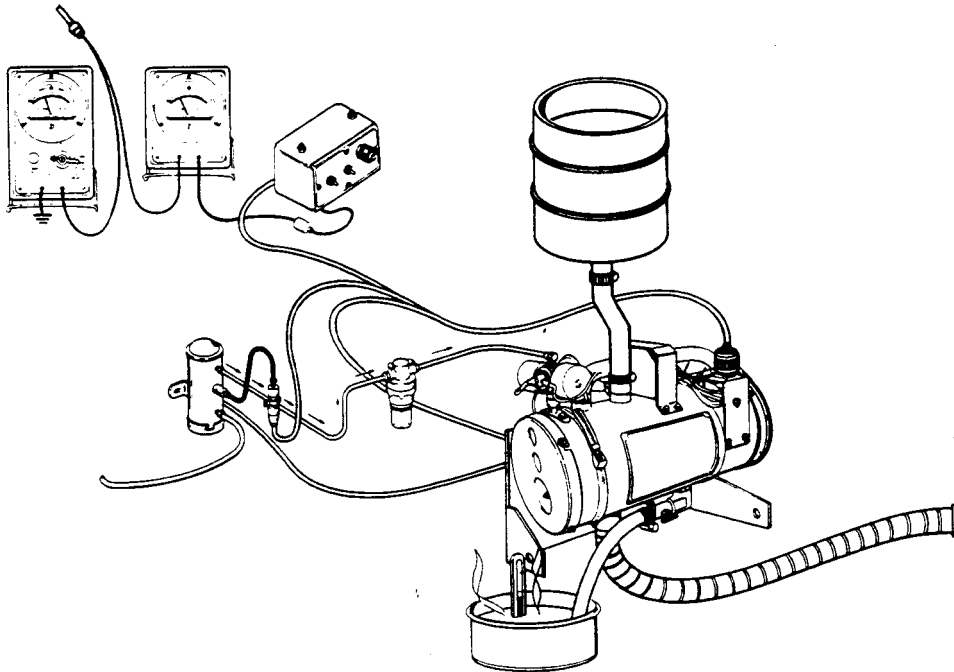

COOLANT SYSTEM

1. Do not use more than 5 gallons of coolant. Use same coolant as in carrier. Do not use water.
2. Change coolant quickly. Allow coolant to cool between tests. The coolant system should have a shutoff valve (1).
3. Vent the coolant container (2) for air. The coolant container may remain open or closed. Use of a thermo-syphon type flow is allowed. No pump is required.

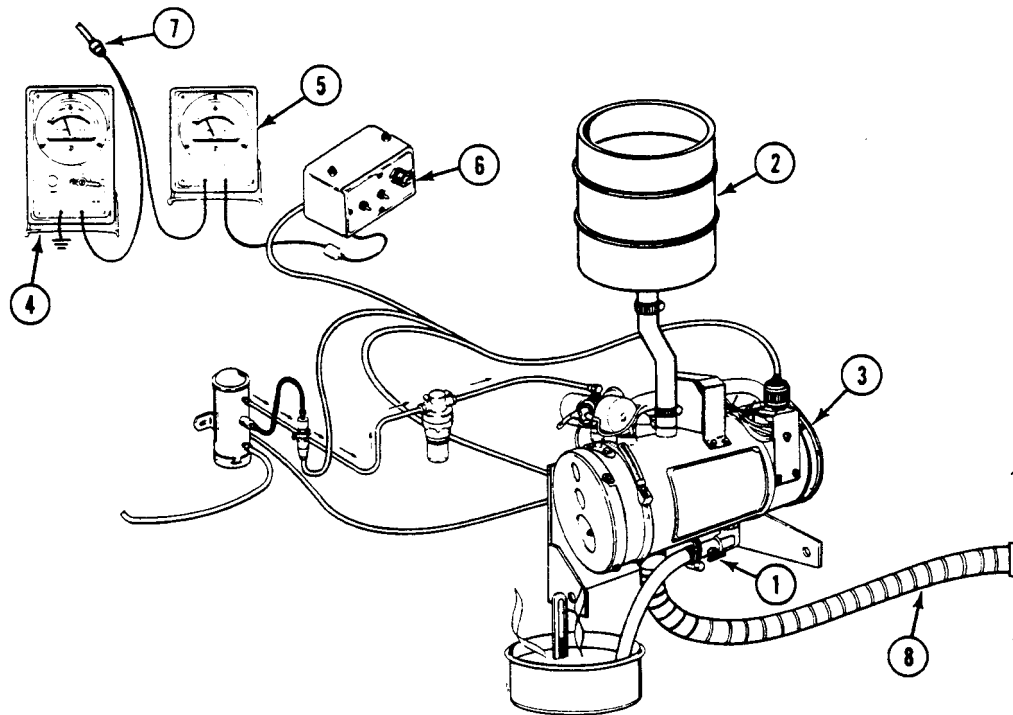

ELECTRICAL WIRING

1. Wire the heater (3) as shown on WP 0075 00, using the regular wiring harness. Connect a voltmeter (4) across the circuit. Insert an ammeter (5) between the hot lead of the control box (6) and the power source (7).
2. Use a fully charged battery for the power source.

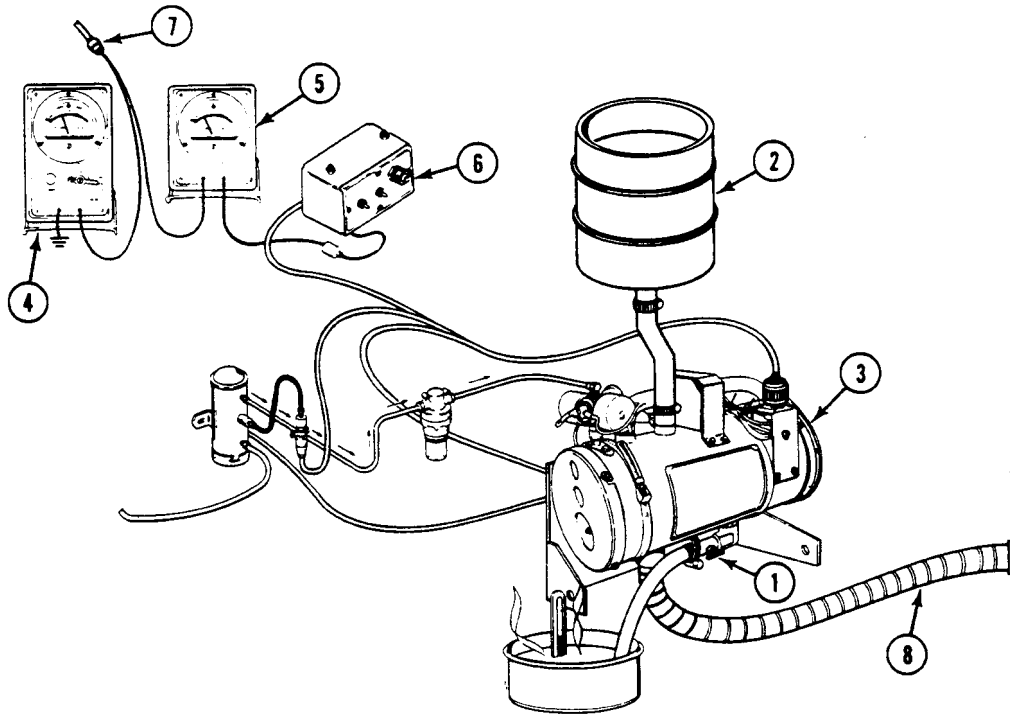

EXHAUST COLLECTOR

1. Conduct the heater exhaust away from the test area. Use an exhaust extension made of flexible hose (8) not more than 10 feet long.

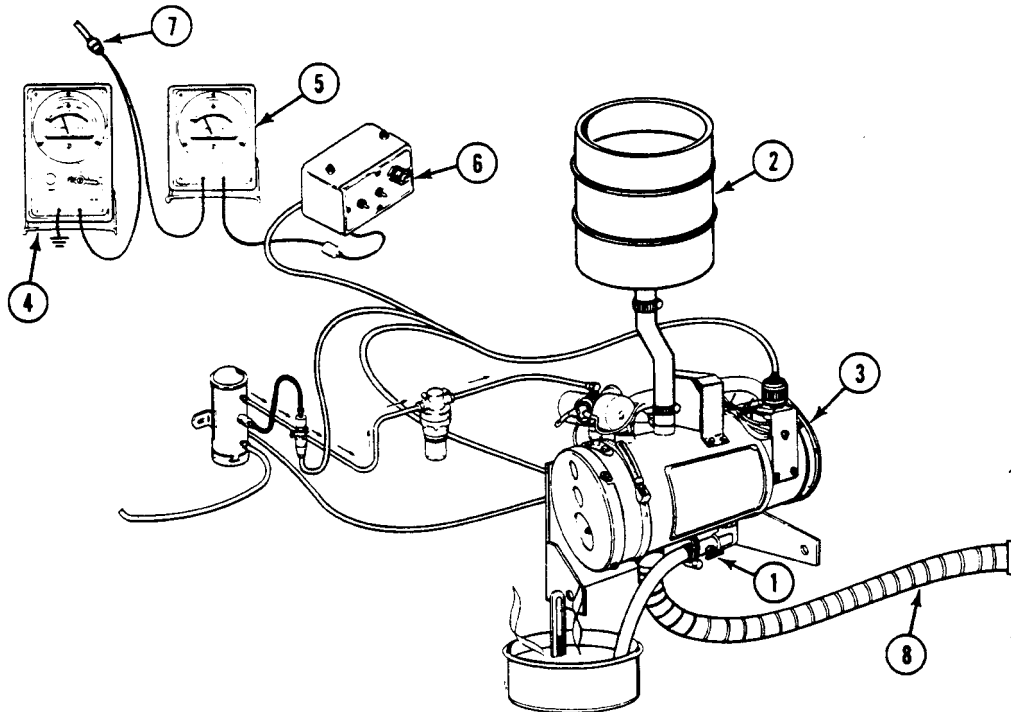
**TESTING**

1. A complete test of the coolant heater consists of the following:
 - a. Fuel flow test (WP 0078 00).
 - b. Burn test.
 - c. Restriction thermostat test.
 - d. Overheat thermostat test.
 - e. Combustion air blower test.
2. Obtaining equipment for the combustion air blower test may be difficult. Do not do this test if the heater burns properly and the igniter cavity does not show undue carbon deposits.
3. Replace the blower if the heater goes out during test or smokes a lot and has heavy carbon deposits in the igniter cavity (WP 0084 00). Moderate carbon deposits are normal and do not indicate a bad blower.

BURN TEST

1. Secure coolant heater to test stand (1) and coolant, fuel, electrical, and exhaust connections. Do not start the heater unless there is an ample supply of coolant.
2. Remove heater end cover (2) and check inside for coolant leakage before starting burn test. Replace heater if coolant has leaked.
3. Place heater control switch in START position and start timing heater immediately.

4. Note ammeter reading. Amperage draw must not exceed 12.8 amps (15.3 amps below 70°F (21°C)).
5. Heater should ignite within 40 seconds from time heater control switch is turned on.
6. The flame detector switch must transfer within 200 seconds. Transfer will be indicated by the pilot lamp and a drop in amperage draw. Move the heater control switch to RUN. Amperage draw must not exceed 1.5 amps (4 amps below 70°F (21°C)).

While burner is igniting and prior to flame switch transfer, check burner seal for signs of fuel leakage. If leakage is present, replace packing gasket (WP 0082 00).

7. If the heater fails to ignite or is slow to set flame, clean the igniter cavity and install a new igniter (see your -20).
8. If the flame detector switch does not transfer within the required time limits, the burner is bad. Replace heater if burner is bad.
9. Allow the heater to burn one minute on HI heat, then move heater control HI-LO switch to LO. Burning and blower speed should continue, but slow down. If the heater goes out, replace the fuel control valve and heater end cover (WP 0078 00).
10. Turn the heater control switch to OFF. Fuel flow and burning should stop in about 30 seconds. Blower should continue to run from 1 to 3 minutes and then stop. If blower does not work within limits, readjust the flame detector switch (see your -20). If the blower still fails to work within limits, replace the flame detector switch (see your -20).

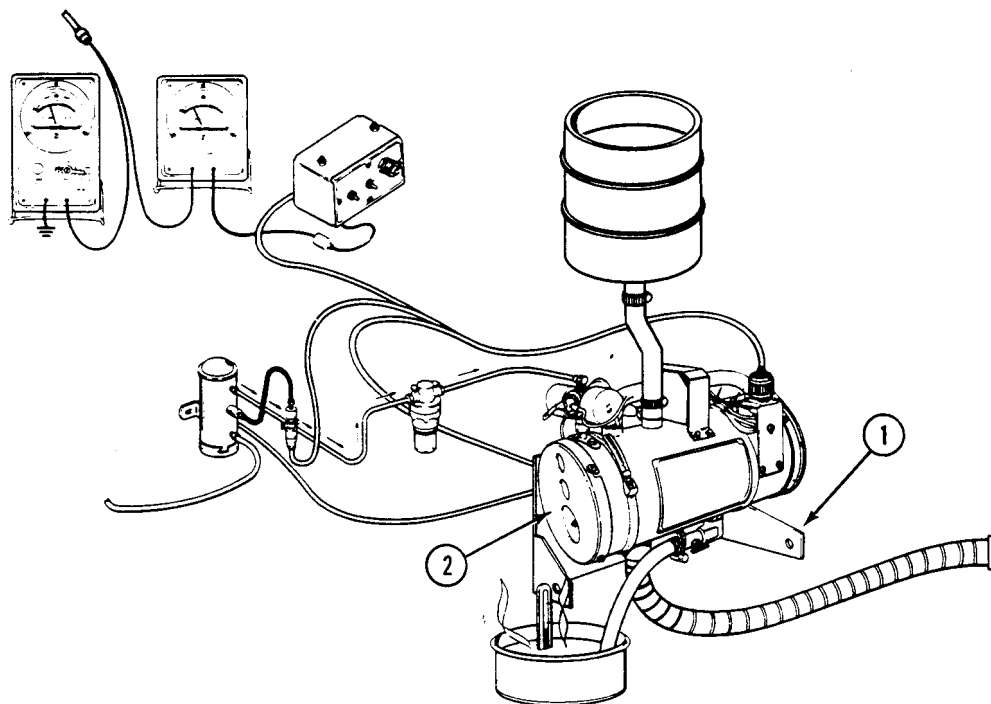

TESTING RESTRICTION AND OVERHEAT THERMOSTATS

NOTE

Thermostat shown in fuel control valve is set to open at 70°F (21°C) and to close at 30°F (-1°C). If temperature is below 70°F (21°C), the heating element in fuel control valve can be energized during any operational cycle.

1. Turn the heater on and run it until the coolant is hot enough to make the heater cycle from high to low heat. Leave the heater alone, then take the temperature of the coolant. The temperature should be between 140°F (60°C) and 170°F (76°C). If coolant temperature is not within limits, replace restriction thermostat (WP 0079 00).
2. After testing the restriction thermostat, close circuit across terminal board terminals No. 4 and No. 5, to make the heater stay on high heat. Heat the coolant until the heater burning stops. Check the temperature of the coolant, it should be not less than 220°F (104°C) or more than 250°F (121°C). If the coolant temperature is not within these limits, replace the overheat thermostat (WP 0080 00).

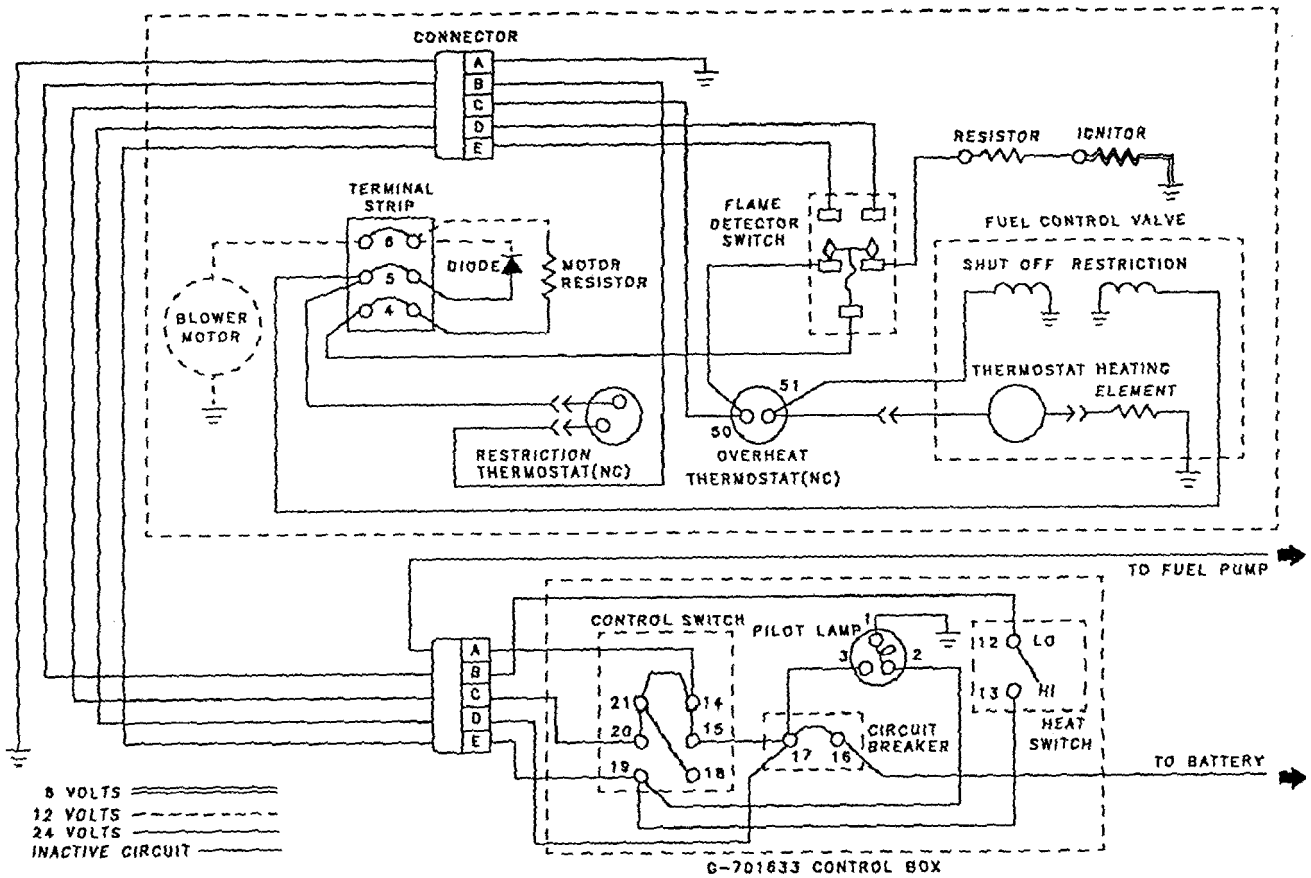

FOLLOW-THROUGH STEPS

1. Install coolant heater in carrier (see your -20).

END OF TASK

REPLACE FUEL CONTROL VALVE

0078 00

THIS WORK PACKAGE COVERS:

- Removal (page 0078 00-1).
 - Fuel flow test (page 0078 00-3).
 - Leak test (page 0078 00-5).
 - Installation (page 0078 00-5).
-

INITIAL SETUP:

Maintenance Level

Direct Support

Personnel Required

Fuel and Elec Sys Rep 63G10

Tools and Special Tools

Automotive Fuel and Electrical System Repair Tool Kit
(WP 0120 00, Item 59)

References

See your -20

Materials/Parts

Insulating varnish (WP 0122 00, Item 18)
Calibrated cubic centimeter container
Overflow receptacle
Watch

Equipment Condition

Engine coolant heater removed from
carrier (see your -20)

REMOVAL

1. Remove nut (1) from union (2) beneath fuel control valve (3).
2. Remove two screws (4) and fuel control valve (3) from bracket (5) and fuel tube (6).

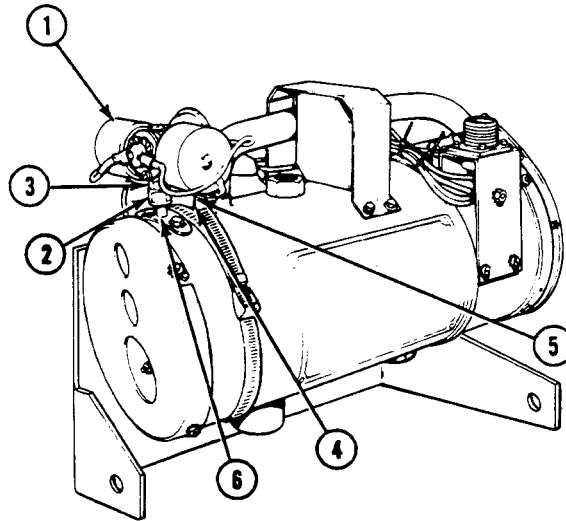

3. Remove four screws (7) and guard (8) from coolant heater (9).

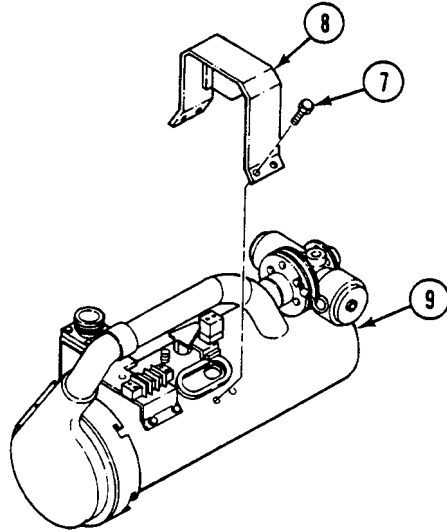

4. Disconnect two fuel control valve leads (10) and (11) from overheat thermostat (12).
5. Disconnect fuel control valve lead (13) from terminal strap (14).

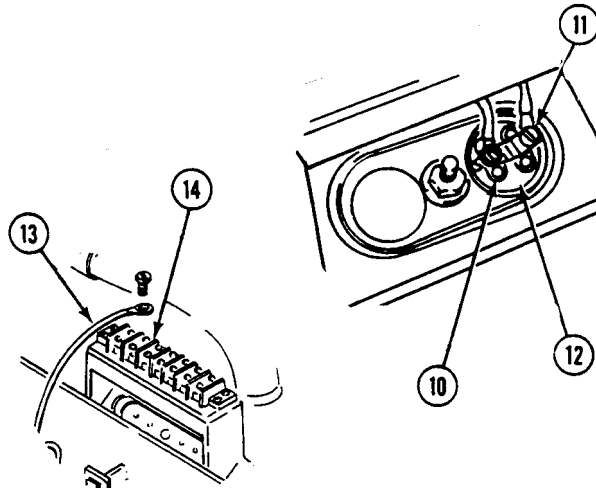

TEST AND INSPECTION

FUEL FLOW TEST

1. Connect fuel control valve to coolant heater fuel hose. Fuel pressure must be 3 to 15 psi (21 to 103 kPa), when fuel valve is open.
2. Place fuel control valve outlet over calibrated and overflow containers.
3. Make sure the body of fuel valve is grounded.
4. Energize fuel valve solenoids. Connect two solenoid leads to a 24 V dc power source. Solenoids are now open for high heat fuel flow.

WARNING



Sparks from static electricity could cause a fire or explosion. Make sure to ground the coolant heater before you open fuel supply valve.

5. Open coolant heater fuel supply valve (WP 0073 00). Bleed fuel hose in a suitable container.
6. After fuel flow is stable, place calibrated cubic centimeter container under fuel control valve.
7. Allow fuel to flow for exactly 1 minute then close coolant heater fuel supply valve. Container should contain 14 ± 2 cubic centimeters of fuel.

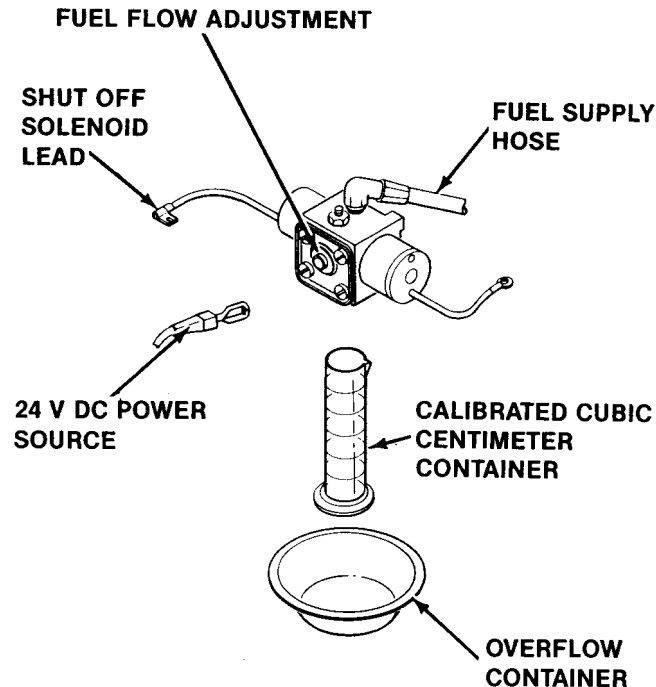

8. Repeat Steps 1 - 7 with shutoff solenoid side only of fuel control valve energized with 24 V dc.
9. Calibrated cubic centimeter glass container should now contain 8.5 ± 2 cubic centimeters of fuel.
10. If fuel flow rates are not within limits, adjust flow. Turn adjusting screw to right to increase and to left to decrease. Adjust high heat flow first, then low heat flow.
11. After fuel flow is adjusted within limits, seal adjusting screw with insulating varnish.
12. If fuel flow cannot be adjusted within limits, replace fuel control valve.

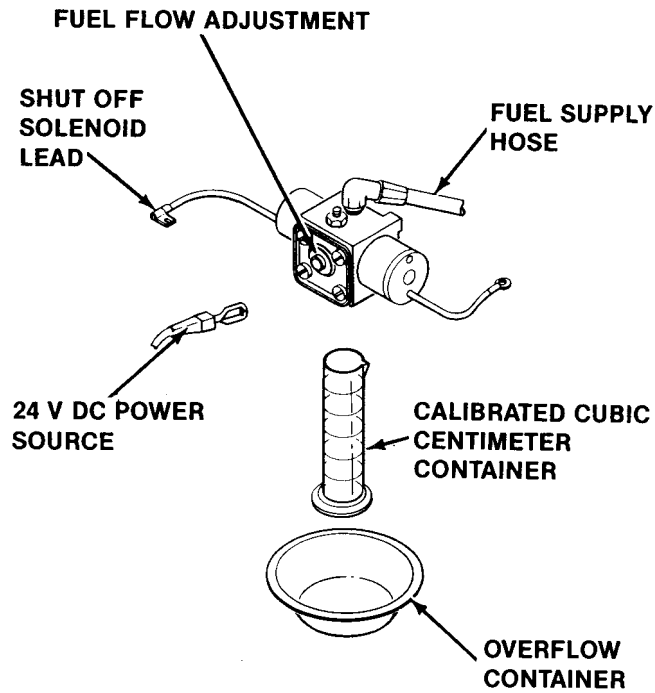

LEAK TEST

1. Repeat high heat fuel flow test. Disconnect both solenoid leads from 24 V dc power source.
2. One or two drops of fuel may form after solenoid leads are disconnected from power source. Further leakage is not acceptable.
3. Replace fuel control valve that leaks.

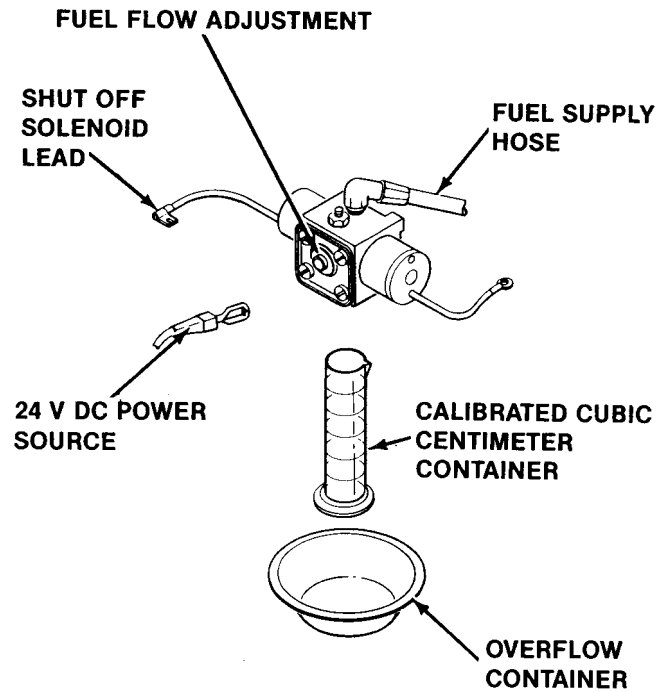

INSTALLATION

1. Connect fuel control valve lead (13) to terminal strap (14).
2. Connect two fuel control valve leads (10) and (11) to overheat thermostat (12).

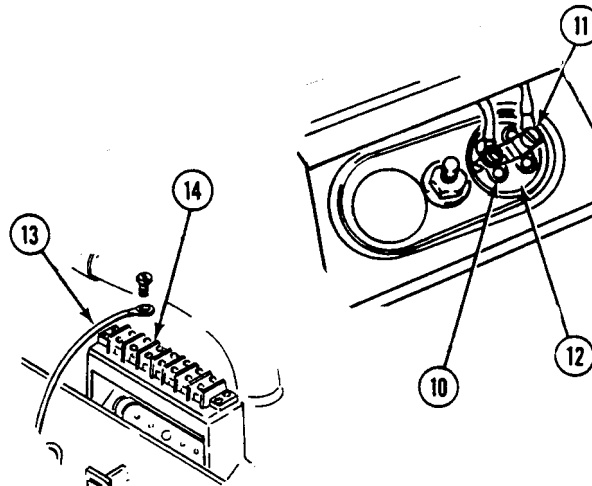

3. Install guard (8) on coolant heater (9). Secure with four screws (7).

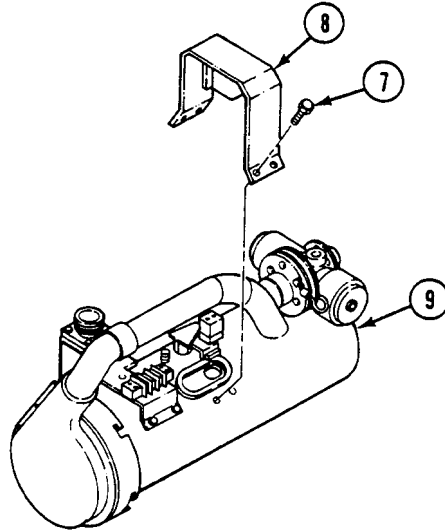

4. Install fuel control valve (1) on bracket (5). Secure with two screws (4).
5. Install fuel control valve (1) on fuel tube (6). Tighten nut (3) on union (2) beneath fuel control valve.

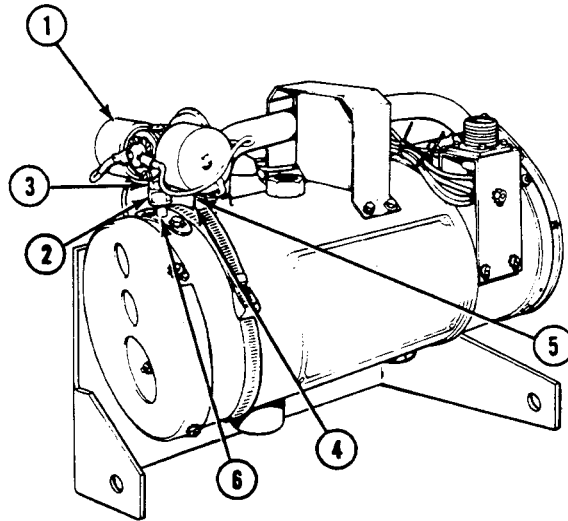

FOLLOW-THROUGH STEPS

1. Install engine coolant heater in carrier (see your -20).

END OF TASK

REPLACE RESTRICTION THERMOSTAT

0079 00

THIS WORK PACKAGE COVERS:

Removal (page 0079 00-1).
 Installation (page 0079 00-2).

INITIAL SETUP:

Maintenance Level

Direct Support

Personnel Required

Fuel and Elec Sys Rep 63G10

Tools and Special Tools

Automotive Fuel and Electrical System Repair Tool Kit
 (WP 0120 00, Item 59)
 Metric Wrench Kit (WP 0120 00, Item 77)

References

See your -20

Materials/Parts

Restriction thermostat

Equipment Condition

Engine coolant heater removed from
 carrier (see your -20)

REMOVAL

1. Remove four screws (1) and guard (2) from coolant heater (3).
2. Remove nut (4), and combustion tube assembly (5) from coolant heater (3) and blower assembly (6).
3. Disconnect blower assembly lead (7) from terminal number 6 of terminal strap (8).
4. Loosen four nuts (9), turn blower assembly (6) counterclockwise to remove blower assembly from coolant heater (3).

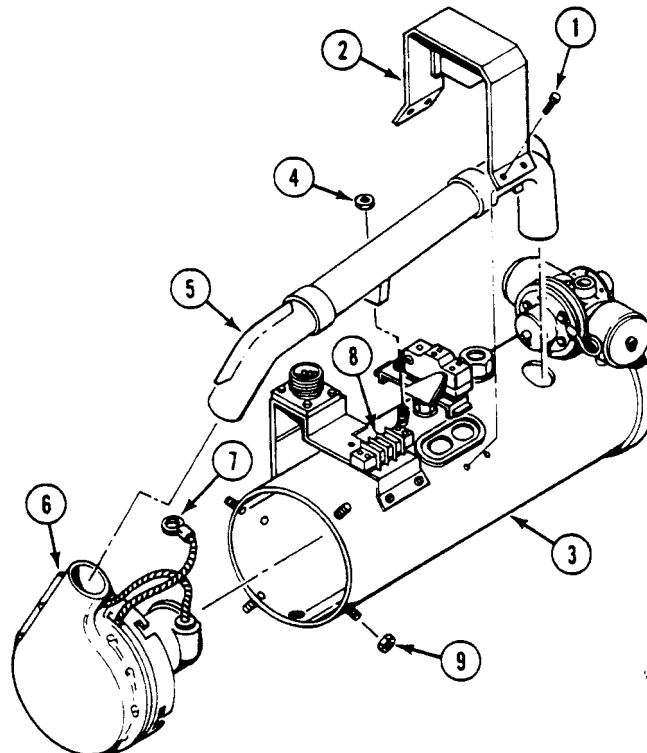

REPLACE RESTRICTION THERMOSTAT — Continued**0079 00**

5. Disconnect two leads (10) from restriction thermostat (11).
6. Remove two nuts (12), washers (13), restriction thermostat (11), and two spacers (14) from heater (3).

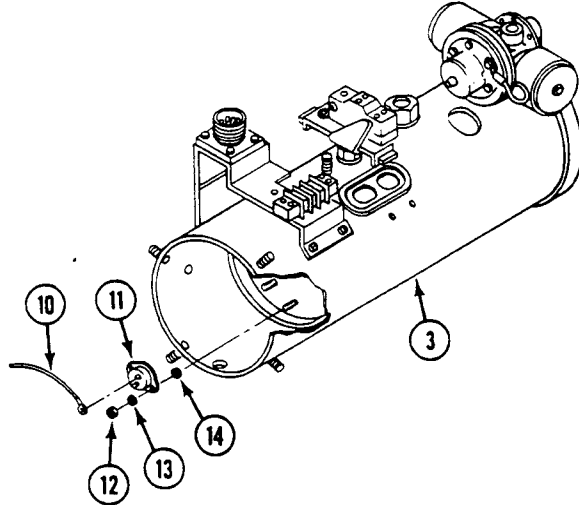
**INSTALLATION**

1. Place two spacers (14) and new restriction thermostat (11) on studs of heater (3). Secure with two washers (13) and nuts (12).
2. Connect two leads (10) to restriction thermostat (11).

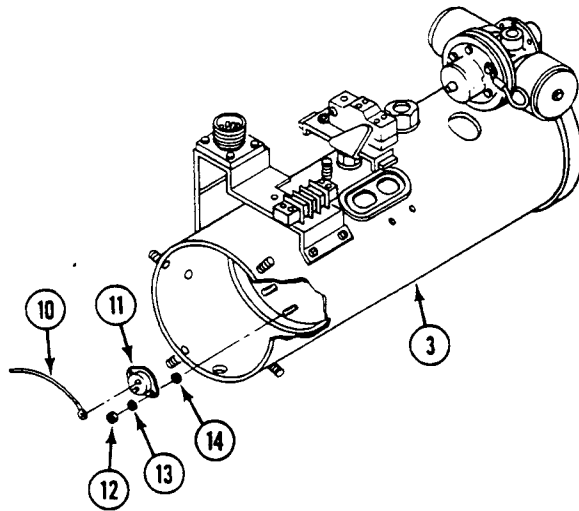

REPLACE RESTRICTION THERMOSTAT — Continued

0079 00

3. Install blower assembly (6) on heater (3) and turn clockwise. Secure with four nuts (9).
4. Connect blower lead (7) to terminal no. 6 of terminal strap (8).
5. Place combustion tube assembly (5) on coolant heater (3) and blower assembly (6). Secure with nut (4).
6. Install guard (2) on coolant heater (3). Secure with four screws (1).

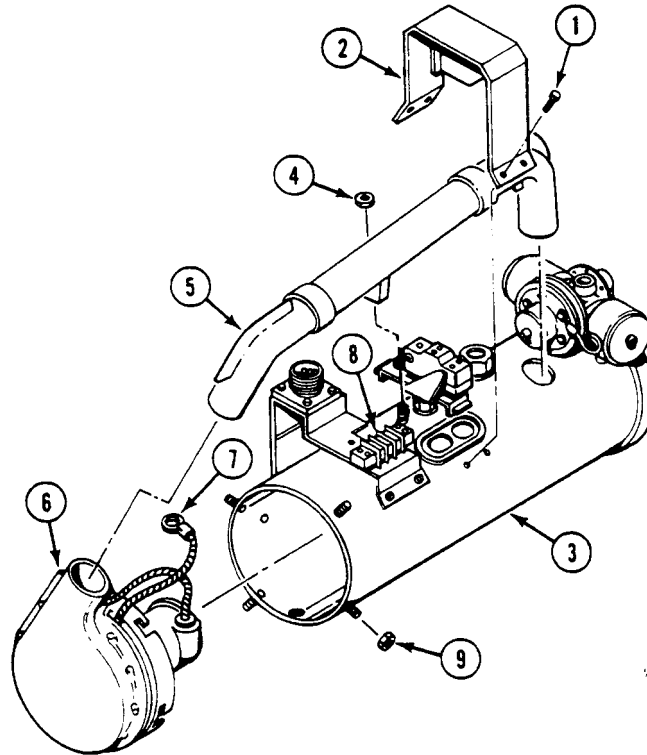
**FOLLOW-THROUGH STEPS**

1. Install engine coolant heater in carrier (see your -20).

END OF TASK

REPLACE OVERHEAT THERMOSTAT

0080 00

THIS WORK PACKAGE COVERS:

Removal (page 0080 00-1).
 Installation (page 0080 00-3).

INITIAL SETUP:

Maintenance Level

Direct Support

Personnel Required

Fuel and Elec Sys Rep 63G10

Tools and Special Tools

Automotive Fuel and Electrical System Repair Tool Kit
 (WP 0120 00, Item 59)
 Digital Multimeter (WP 0120 00, Item 38)

References

See your -20

Materials/Parts

Lockwasher
 Packing
 Thermostatic switch

Equipment Condition

Engine coolant heater removed from
 carrier (see your -20)

REMOVAL

1. Remove four screws (1) and guard (2) from coolant heater (3).

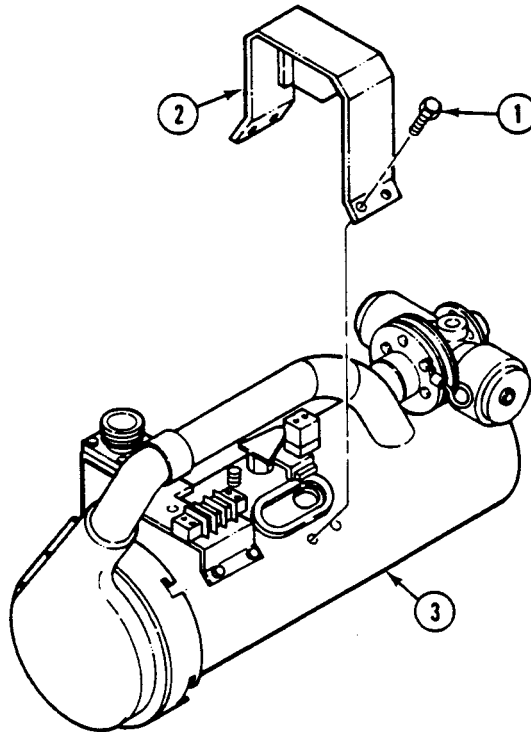

REPLACE OVERHEAT THERMOSTAT — Continued

0080 00

2. Disconnect two leads (4) from overheating thermostat (5).
3. Remove nut (6), lockwasher (7), and retainer (8) from heater (3). Discard lockwasher.
4. Remove overheating thermostat (5), packing (9), and washer (10) from heater (3). Discard packing.

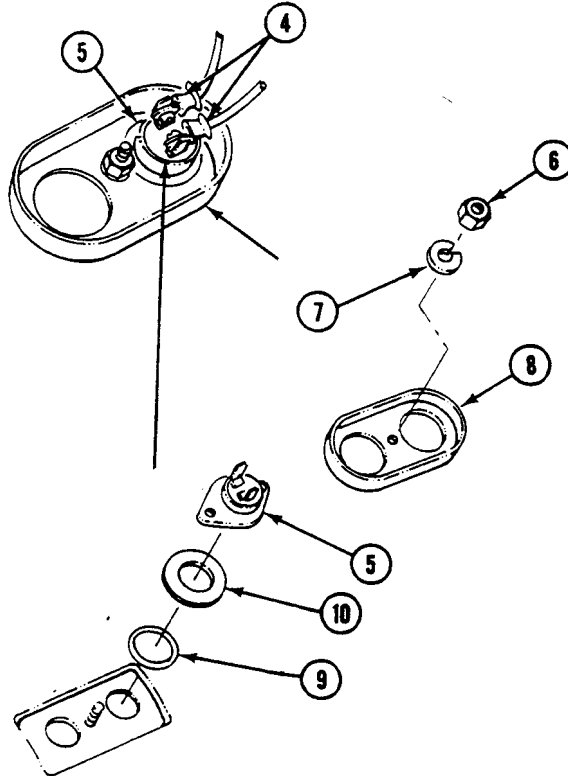

5. Use multimeter to check resistance through overheat thermostat.
6. Multimeter should read 0 ohms. If reading is infinity, replace overheat thermostat.

INSTALLATION

1. Install new packing (1), washer (2), and overheat thermostat (3) in coolant heater (4). Secure with retainer (5), new lock washer (6), and nut (7).
2. Connect two leads (8) to overheat thermostat (3).

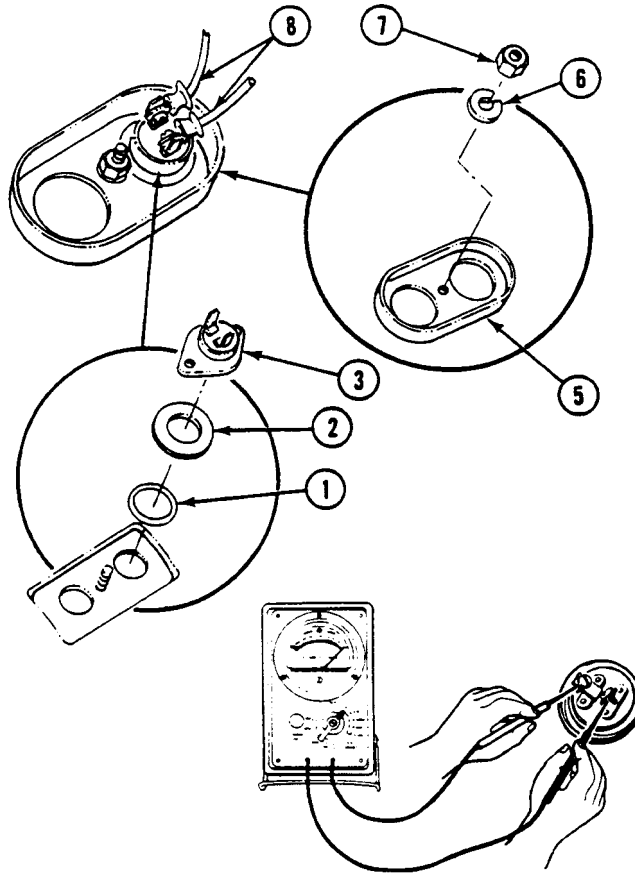

3. Install guard (2) on heater (3). Secure with four screws (1).

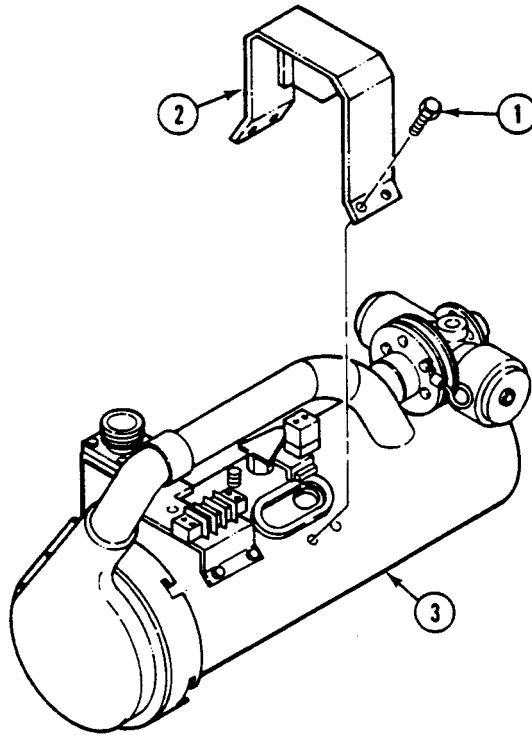
**FOLLOW-THROUGH STEPS**

1. Install engine coolant heater in carrier (see your -20).

END OF TASK

REPLACE FIXED RESISTOR

0081 00

THIS WORK PACKAGE COVERS:

Removal (page 0081 00-1).
 Installation (page 0081 00-2).

INITIAL SETUP:

Maintenance Level

Direct Support

Materials/Parts

Sleeve

Personnel Required

Fuel and Elec Sys Rep 63G10

Tools and Special Tools

Automotive Fuel and Electrical System Repair Tool Kit
 (WP 0120 00, Item 59)

Digital Multimeter (WP 0120 00, Item 38)

Metric Wrench Kit (WP 0120 00, Item 77)

References

See your -20

Equipment Condition

Engine coolant heater removed from
 carrier (see your -20)

REMOVAL

1. Remove two screws (1) and fuel control valve bracket (2) from coolant heater (3).
2. Loosen four nuts (4), and remove end cover (5) from heater (3).
3. Remove two screws (6) that secure tapping plate (7), flange (8), and fuel tube (9) to heater (3).
4. Remove nut (10), fixed resistor (11), flange (8), fuel tube (9), and sleeve (12) from heater (3).
5. Remove nut (13), screw (14), and electrical lead (15) from fixed resistor (11).

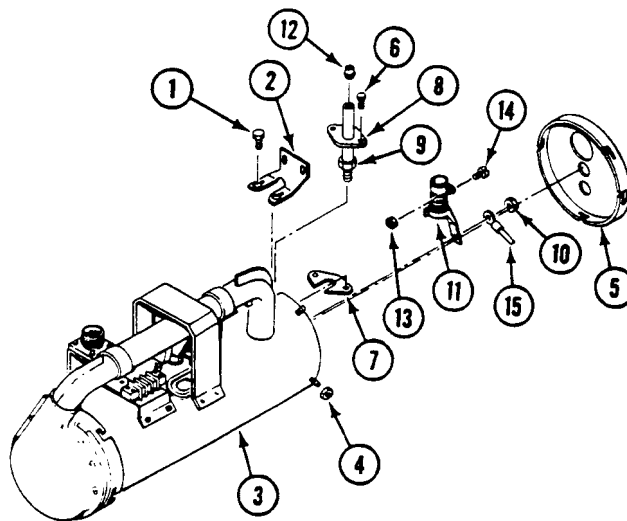

REPLACE FIXED RESISTOR — Continued

0081 00

6. Use multimeter (16). Check resistance from circuit 7 terminal end (17) to strap end (18) of fixed resistor (11).
7. Multimeter should read 1.6 to 1.7 ohms. If reading is not in range, replace fixed resistor.

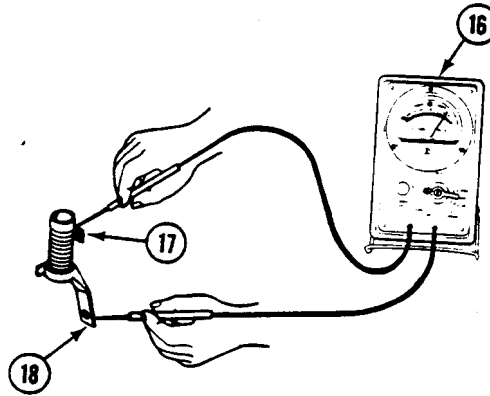
**INSTALLATION**

1. If fixed resistor (11) is to be replaced, grind or cut sleeve (12) off of fuel tube (9). Discard sleeve.
2. Install fixed resistor (11) and new sleeve (12) on fuel tube (9).
3. Secure electrical lead (15) to fixed resistor (11) with screw (14) and nut (13).
4. Secure fixed resistor (11) to heater (3) with nut (10).
5. Secure fuel tube (9), flange (8), and tapping plate (7) to heater (3) with two screws (6).
6. Install end cover (5) on heater (3). Tighten four nuts (4).
7. Secure fuel control valve bracket (2) to heater (3) with two screws (1).

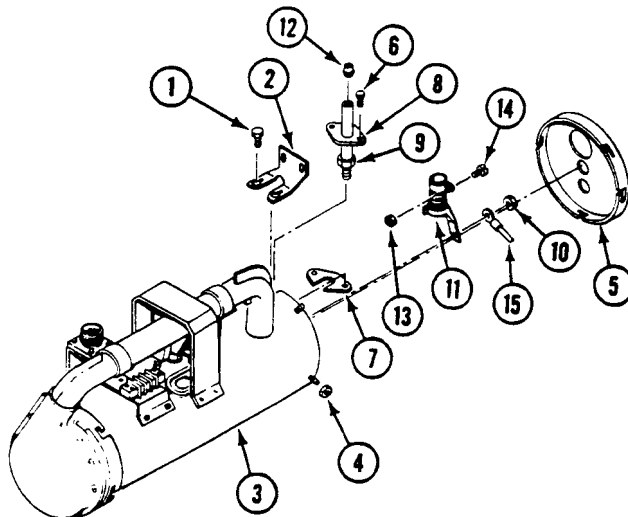
**FOLLOW-THROUGH STEPS**

1. Install engine coolant heater in carrier (see your -20).

END OF TASK

REPLACE BURNER PACKING AND GASKET

0082 00

THIS WORK PACKAGE COVERS:

- Removal (page 0082 00-1).
- Installation (page 0082 00-2).

INITIAL SETUP:

Maintenance Level

Direct Support

Personnel Required

Fuel and Elec Sys Rep 63G10

Tools and Special Tools

- Automotive Fuel and Electrical System Repair Tool Kit (WP 0120 00, Item 59)
- Metric Wrench Kit (WP 0120 00, Item 77)

References

See your -20

Materials/Parts

- Gasket
- Preformed packing

Equipment Condition

- Engine coolant heater removed from carrier (see your -20)
- Fixed resistor removed (WP 0081 00)
- Fuel control valve removed (WP 0078 00)

REMOVAL

1. Remove screw (1), washer (2) and ground strap (3) from burner assembly (4).
2. Remove four nuts (5), bolts (6), clamps (7), and burner (4) from heater (8).
3. Remove preformed packing (9) and gasket (10) from burner (4). Discard preformed packing and gasket.

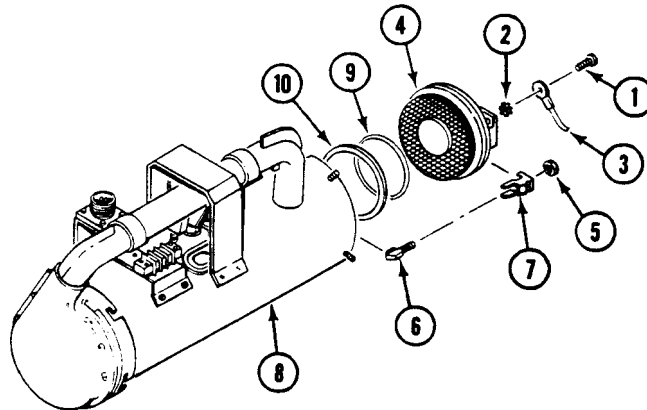

INSTALLATION

1. Install new preformed packing (9) and new gasket (10) in groove of burner (4).
2. Place burner (4) in heater (8). Secure with four nuts (5), bolts (6), and clamps (7).
3. Install ground strap (3) on burner (4). Secure with screw (1) and washer (2).

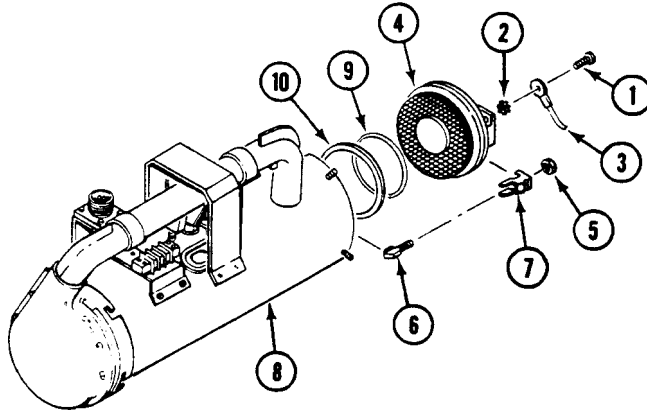
**FOLLOW-THROUGH STEPS**

1. Install fixed resistor (WP 0081 00).
2. Install fuel control valve (WP 0078 00).
3. Install engine coolant heater in carrier (see your -20).

END OF TASK

REPLACE DIODE AND MOTOR RESISTOR

0083 00

THIS WORK PACKAGE COVERS:

Removal (page 0083 00-1).
 Inspection-Acceptance and Rejection Criteria (page 0083 00-2).
 Installation (page 0083 00-3).

INITIAL SETUP:

Maintenance Level

Direct Support

Personnel Required

Fuel and Elec Sys Rep 63G10

Tools and Special Tools

Automotive Fuel and Electrical System Repair Tool Kit
 (WP 0120 00, Item 59)
 Digital Multimeter (WP 0120 00, Item 38)
 Metric Wrench Kit (WP 0120 00, Item 77)

References

See your -20

Equipment Condition

Engine coolant heater removed from carrier
 (see your -20)

REMOVAL

1. Remove four screws (1) and guard (2) from heater (3).

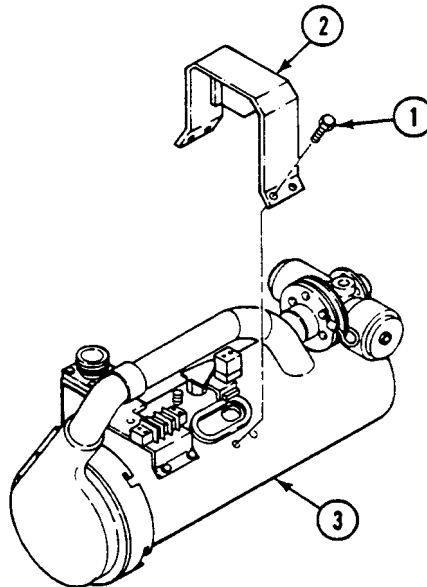

NOTE

Note direction of arrow on diode so it can be installed later.

2. Remove diode (4) from holder (5).
3. Remove motor resistor (6) leads from terminals No. 4 and No. 6 on terminal board (7).

- Remove nut (8), screw (9), and motor resistor (6) from bracket (10).

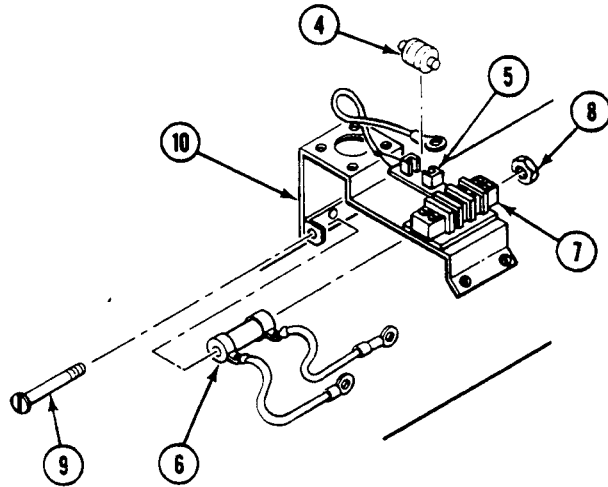

INSPECTION-ACCEPTANCE AND REJECTION CRITERIA

- Use multimeter to check diode. Set meter to above 200 ohms range. Place probes on each end of diode and note reading. Switch probes and note reading. One reading must indicate continuity and other reading must indicate high resistance, if they do not replace diode.

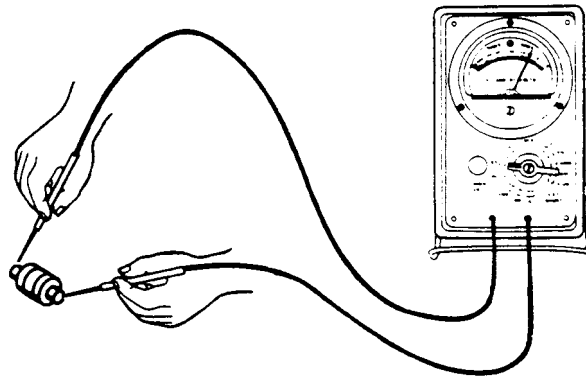

- Use multimeter to check motor resistor. Multimeter must read 250-300 ohms. Replace out of range resistor.

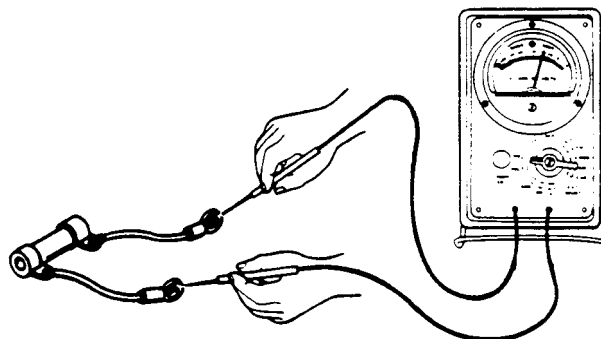

INSTALLATION

1. Install motor resistor (6) on bracket (10) with screw (9) and nut (8).
2. Secure motor resistor (6) leads to terminals No. 4 and No. 6 of terminal board (7).
3. Install diode (4) in holder (5).

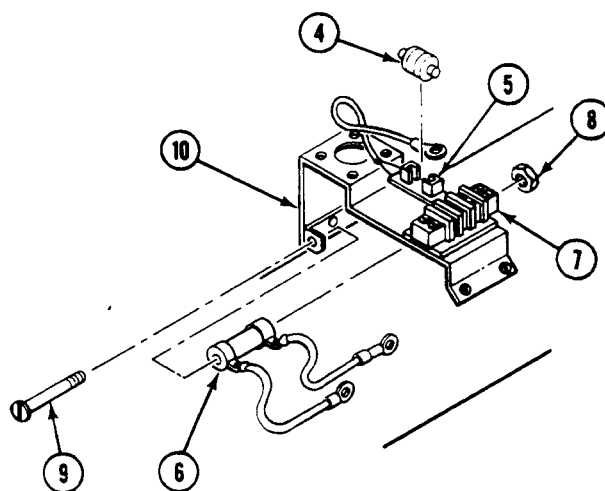

4. Install guard (2) on heater (3). Secure with four screws (1).

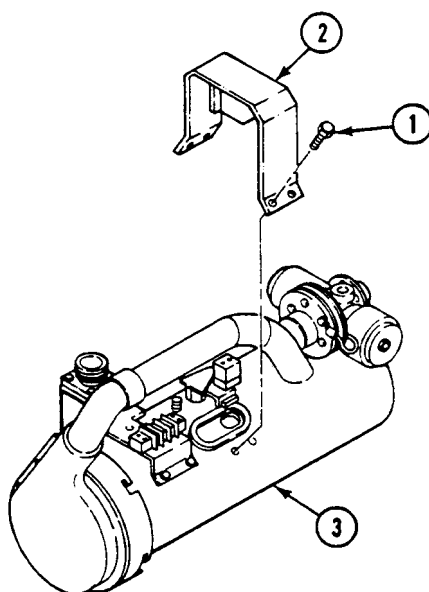
**FOLLOW-THROUGH STEPS**

1. Install engine coolant heater in carrier (see your -20).

END OF TASK

REPLACE BLOWER MOTOR

0084 00

THIS WORK PACKAGE COVERS:

Removal (page 0084 00-1).
 Installation (page 0084 00-2).

INITIAL SETUP:

Maintenance Level

Direct Support

References

See your -20

Tools and Special Tools

Automotive Fuel and Electrical System Repair Tool Kit
 (WP 0120 00, Item 59)
 Metric Wrench Kit (WP 0120 00, Item 77)

Equipment Condition

Engine coolant heater removed from
 carrier (see your -20)

Personnel Required

Fuel and Elec Sys Rep 63G10

REMOVAL

1. Remove four screws (19) and guard (18) from coolant heater (12).
2. Remove nut (17) and combustion tube assembly (16) from coolant heater (12) and blower assembly (11).
3. Disconnect blower assembly lead (14) from terminal strap (15) terminal No. 6.
4. Scribe a line on blower assembly (11) and on coolant heater (12) for proper alignment.
5. Loosen four nuts (13) and turn blower assembly (11) to left and remove blower assembly from coolant heater (12).

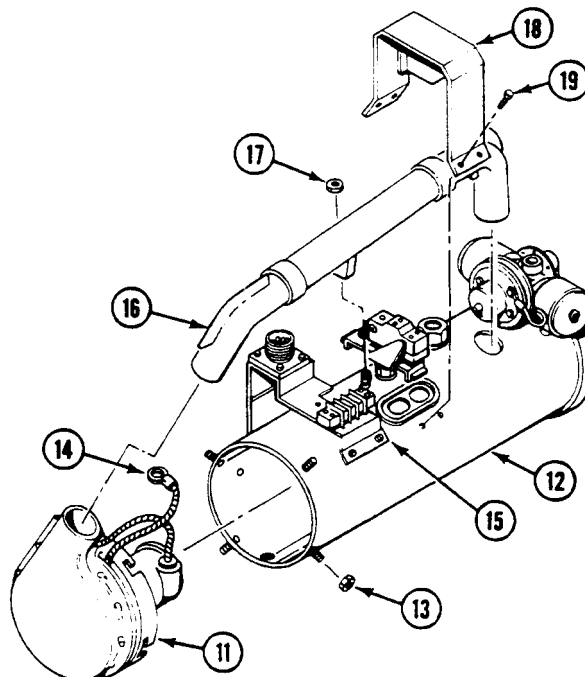

REPLACE BLOWER MOTOR — Continued

0084 00

6. Remove seven screws (10), speed nuts (11), and cover (12) from blower plate (13).
7. Loosen set screw (14) and remove fan vane (15) from motor (16).
8. Remove three screws (17), spacers (18), grommets (19), and motor (16) from blower plate (13).

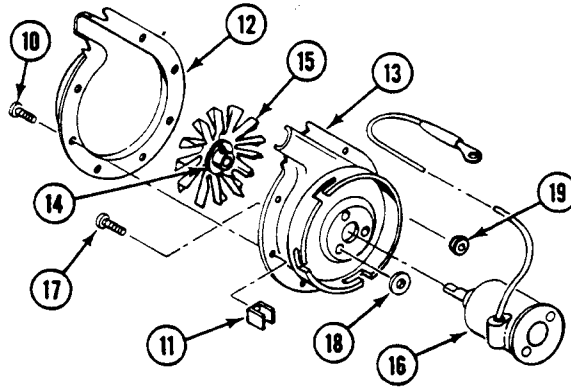
**INSTALLATION**

1. Install motor (16) in blower plate (13). Secure with three screws (17), spacers (18), and grommets (19).
2. Place fan vane (15) flush with end of motor shaft. Secure with set screw (14).
3. Install cover (12) on blower plate (13). Secure with seven screws (10) and speed nuts (11). Turn fan vane (15) through combustion tube opening to make sure fan vane is clear.

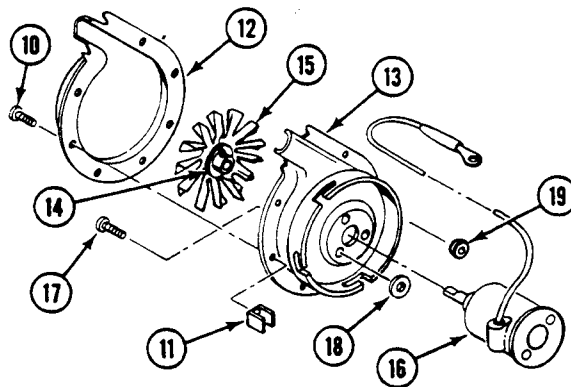

REPLACE BLOWER MOTOR — Continued

0084 00

4. Place blower assembly (11) on heater (12) and turn to the right. Secure with four nuts (13).
5. Connect blower assembly lead (14) to terminal strap (15) terminal No. 6.
6. Place combustion tube assembly (16) on coolant heater (12) and blower assembly (11). Secure with nut (17).
7. Install guard (18) on coolant heater (12). Secure with four screws (19).

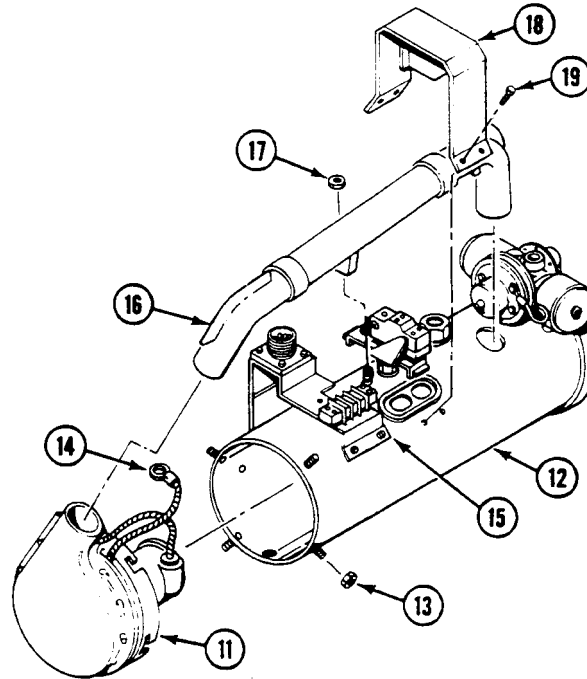
**FOLLOW-THROUGH STEPS**

1. Install coolant heater in carrier (see your -20).

END OF TASK

INSTALL NON-SKID RAMP KIT (M1064A3 ONLY)

0085 00

THIS WORK PACKAGE COVERS:

- Prepare ramp (page 0085 00-1).
- Installation (page 0085 00-4).

INITIAL SETUP:

Maintenance Level

Direct Support

Personnel Required

Track Vehicle Repairer 63H10

Tools and Special Tools

- General Mechanic's Tool Kit (WP 0120 00, Item 62)
- Portable Electric Drill (WP 0120 00, Item 7)
- Pneumatic Hammer (WP 0120 00, Item 20)
- Electrical Disc Sander (WP 0120 00, Item 47)
- Screw Threading Set (WP 0120 00, Item 58)

References

See your -10

Materials/Parts

- Non-skid ramp kit P/N 10942588
- Wood blocks, 6 x 6 x 12 inches (2)

Equipment Condition

- Engine stopped (see your -10)
- Carrier blocked (see your -10)

INSTALLATION

PREPARE RAMP

1. Place two wood blocks at rear of carrier. Position blocks so ramp and ramp door will rest on blocks when lowered.
2. Lower ramp (see your -10) onto blocks.
3. Remove ramp door handle stop (1). Discard stop. Use pneumatic hammer.

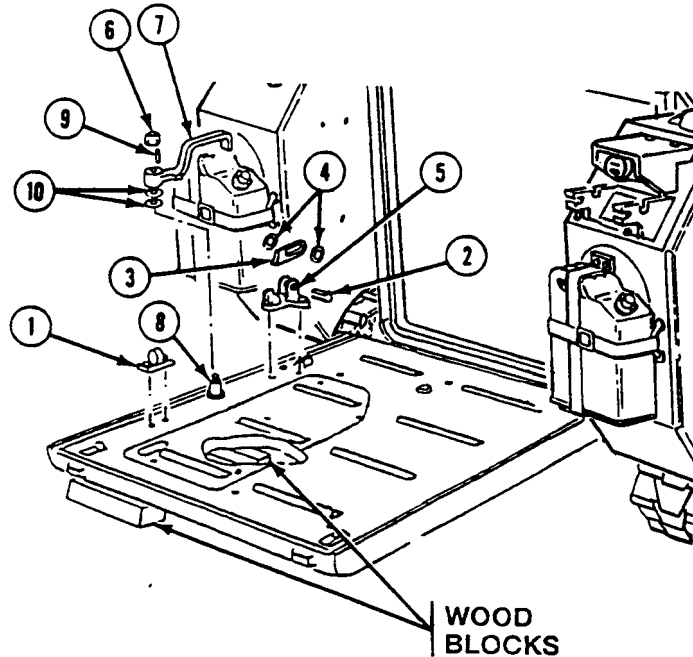

INSTALL NON-SKID RAMP KIT (M1064A3 ONLY) — Continued**0085 00**

4. Grind weld area smooth. Use sander.
5. Remove spring pin (2) that secures handle release (3) and two washers (4) to release bracket (5). Keep release, spring pin, and washers.
6. Remove bracket (5). Discard bracket. Use pneumatic hammer.
7. Grind weld area smooth. Use sander.
8. Remove nut (6) that secures inner handle (7) to outer handle (8). Remove handles, key (9), and shim washers (10). Discard inner handle (7). Keep nut, key, and shim washers.

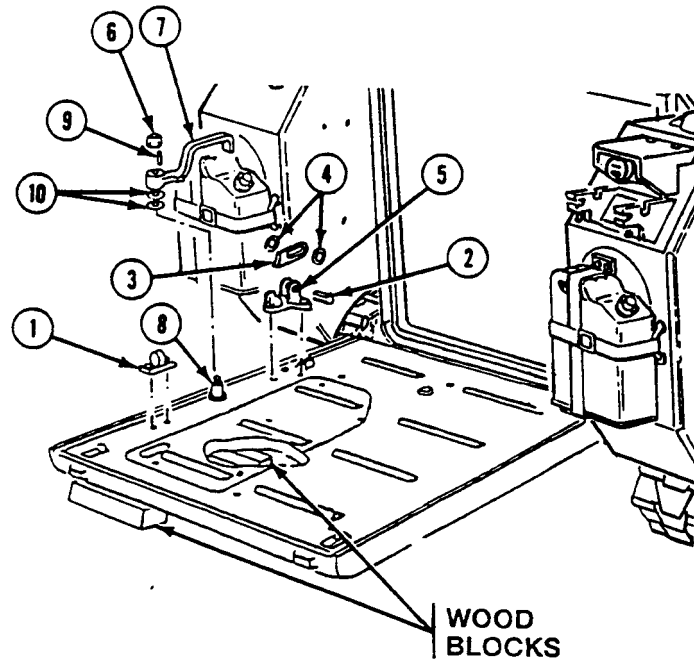

NOTE

All dimensions shown in the following illustration are in inches and metric equivalents.
Dimension tolerances are $\pm 1/16$ inch (2 mm), unless otherwise indicated.

9. Locate, drill, and thread mounting holes as explained in following illustration and text.
10. Place ramp non-skid plate on ramp to use as a template to locate five holes. Drill five holes with $27/64$ inch (11 mm) drill. Tap holes 1/2-13 UNC-2B to at least 1 inch (3 cm) deep. Use screw threading set.
11. Place ramp door non-skid plate on ramp door to use as a template to locate four holes. Drill four holes with $27/64$ inch (11 mm) drill. Tap holes 1/2-13 UNC-2B at least 1 inch (3 cm) deep. Use screw threading set.
12. Place new handle stop and new release bracket on ramp to use as template to locate five holes. Drill five holes with $5/16$ inch (8 mm) drill. Tap holes 3/8-16 UNC-2B to at least 1 inch (3 cm) deep. Use screw threading set.

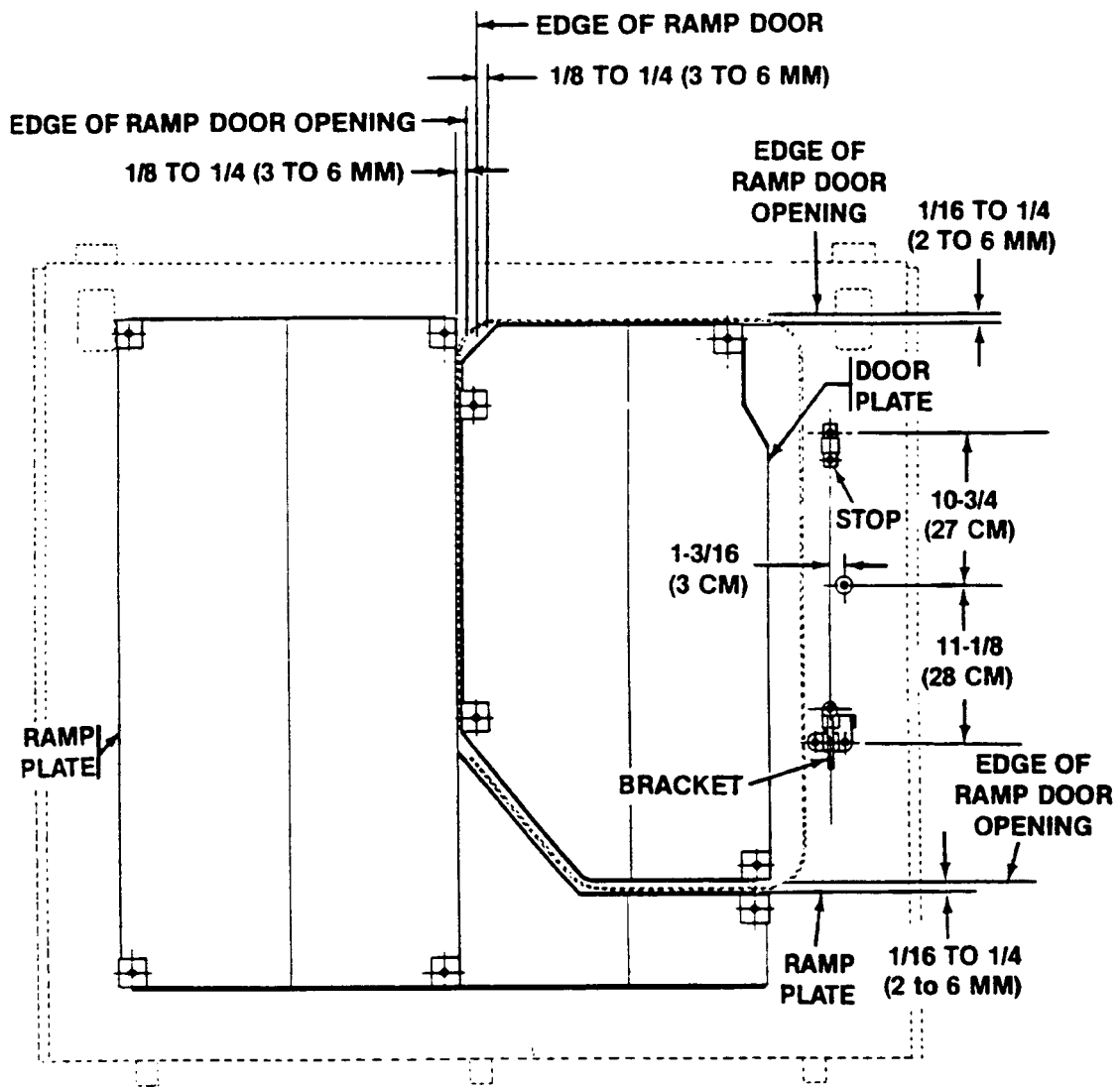

INSTALL

1. Place bracket spacer (1) and release bracket (2) on ramp (3). Secure with three key washers (4) and screws (5).
2. Place handle release (6) with one washer (7) on each side in release bracket (2). Secure with spring pin (8).
3. Place stop spacer (9) and handle stop (10) on ramp (3). Secure with two key washers (11) and screws (12).
4. Place ramp non-skid plate (13) on ramp (3). Secure with five key washers (14) and screws (15).
5. Place ramp door non-skid plate (16) on ramp door (17). Secure with four key washers (18) and screws (19).
6. Bend one tab of each key washer (4), (11), (14), and (18) up against flat of each screw (5), (12), (15), and (19).
7. Insert outer handle (20) in ramp with at least one shim (21). Install at least one shim (21), key (22), inner handle (23), and nut (24) on handle (20).
8. Turn handle (23) to lock ramp door. Then, raise ramp (see your -10).
9. Open and close door, checking door action and handle end play. Adjust per Step 10.
10. Add or remove shims (21) on either side of ramp, as needed, to keep ramp door flush with outside of ramp. Ramp door must be within 1/32 inch (2 mm) with outside of ramp. There must be no handle end play.

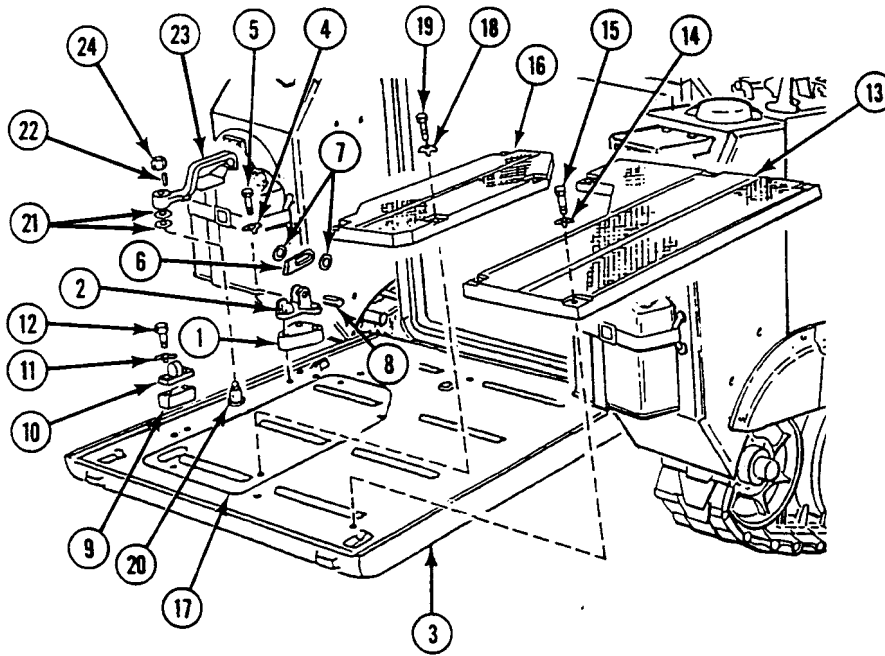

FOLLOW-THROUGH STEPS

1. Start engine (see your -10).
2. Raise and lock ramp (see your -10).
3. Stop engine (see your -10).
4. Remove wood blocks from ramp area.

END OF TASK

INSTALL CAPSTAN KIT (M1059A3 ONLY)

0086 00

THIS WORK PACKAGE COVERS:

Installation (page 0086 00-1).

INITIAL SETUP:

Maintenance Level

Direct Support

Personnel Required

Metalbody Repairer 44B

Tools and Special Tools

- General Mechanic's Tool Kit (WP 0120 00, Item 62)
- Trailer Mounted Welding Shop (WP 0120 00, Item 69)
- Measuring Tape (WP 0120 00, Item 57)
- Torque Wrench (WP 0120 00, Item 73)

References

- See your -10
- See your -20
- TM 9-237
- TM 43-0139

Materials/Parts

- Welding Electrode (WP 0122 00, Item 35)
- Kit P/N 5703657

Equipment Condition

- Engine stopped (see your -10)
- Carrier blocked (see your -10)
- Carrier on level surface with tracks removed from sprockets (see your -20)

INSTALLATION

1. Mark cutting lines as shown in the upper view of the illustration for your carrier's cover (left side).
2. Use hacksaw and cut the front cover, as needed, along the cutting lines. The final cut should look like the lower view of the illustration of your carrier's cover (left side).
3. Repeat above Step 1 and Step 2 on the right side of your carrier.
4. Smooth out any sharp edges that may remain on the cover with a round file.

MARKING FOR CUTTING LINES

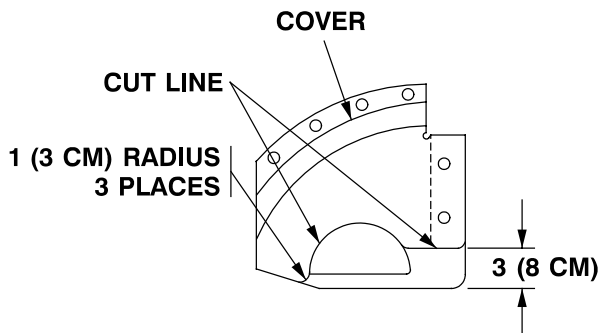

12 INCH (30 CM) SHROUD COVER (WITH STEP)

AFTER CUTTING

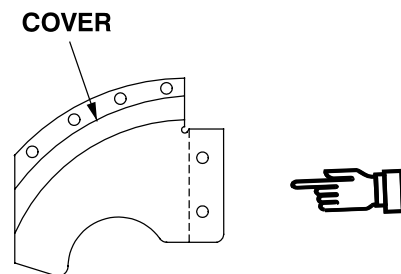

12 INCH (30 CM) SHROUD COVER (WITH STEP)

NOTE

Two types of screws are provided in capstan kit. One type of screw is for counterbore holes in sprocket. The other type of screw is for holes without counterbore construction. Twenty of each type of screw are provided. Use as applicable.

5. Remove 10 screws (1) from left sprocket (2) and 10 screws from right sprocket.

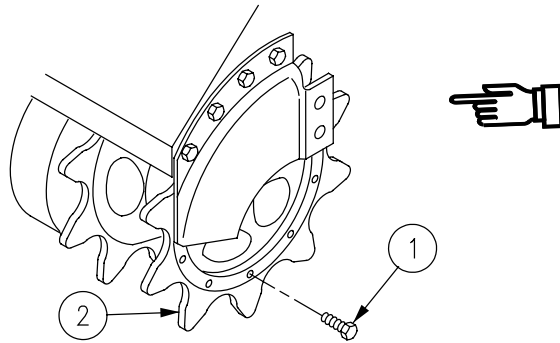

6. Place two adapters (3) on two sprockets (2).
7. Secure adapters (3) to sprockets (2) with 20 screws (4). Tighten screws to 110-115 lb-ft (149-156 N·m) torque.

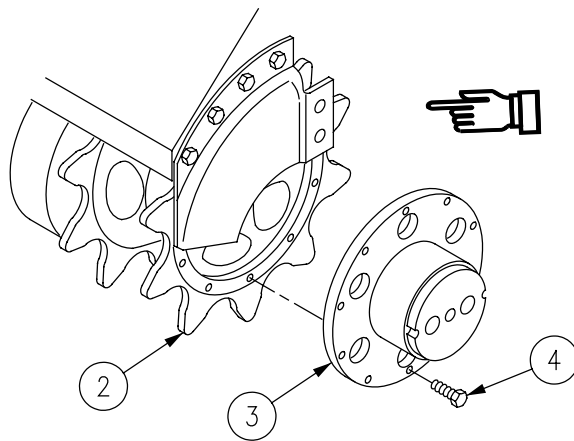

8. Make sure retainer (5) is installed in drum (6) with pin (7).
9. Install drum (6) on adapter (3). Secure with retainer (5).

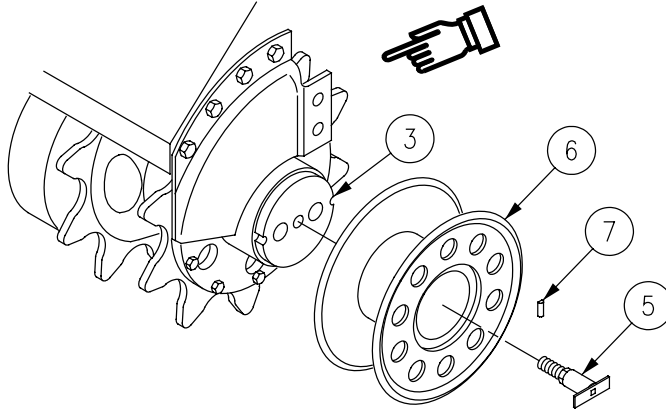

10. Measure and mark the correct positions for the smaller stowage support (1) and for the larger support (2) on top of carrier.

NOTE

All weld sizes are minimum. Do not exceed 1/16 inch (2 mm) over specified sizes.

11. Remove all paint, anodize, and debris from surfaces under stowage supports to be welded.
12. Weld supports (1) and (2) to top plate of carrier as marked in Step 10 in accordance with TM 9-237. Use electrode type 5356.
13. Clean weld area and apply touch-up paint to repaired area (see TM 43-0139).
14. Unscrew two retainers (3) to remove two drums (4) from two adapters (5).
15. Place one drum (4) over stowage support (1). Place the other drum (4) over stowage support (2). Secure with two retainers (3).

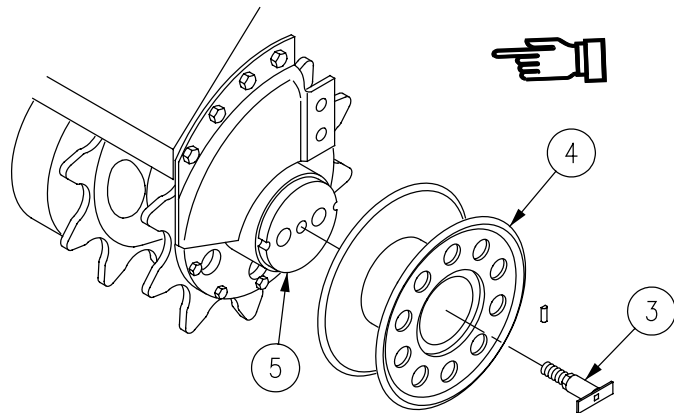
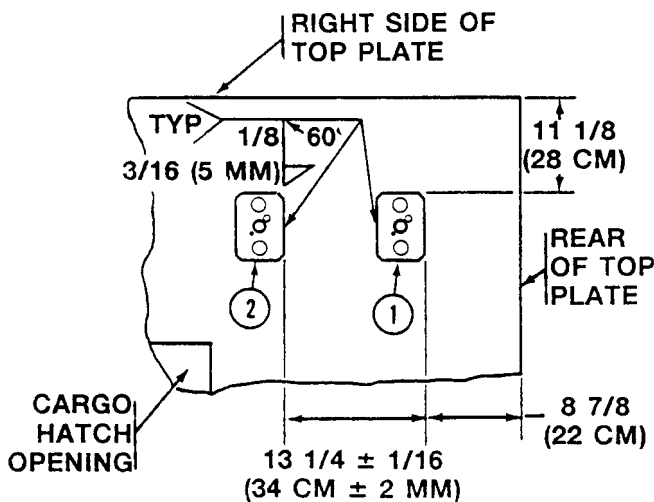

FOLLOW-THROUGH STEPS

1. Install tracks on carrier (see your -20).

END OF TASK

INSTALL ANCHOR KIT (M1059A3 ONLY)

0087 00

THIS WORK PACKAGE COVERS:

Installation (page 0087 00-1).

INITIAL SETUP:

Maintenance Level

Direct Support

Personnel Required

Track Vehicle Repairer 63H10

Tools and Special Tools

- General Mechanic's Tool Kit (WP 0120 00, Item 62)
- Portable Electric Drill (WP 0120 00, Item 7)
- Twist Drill Set (WP 0120 00, Item 10)
- Measuring Tape (WP 0120 00, Item 57)
- Screw Threading Set (WP 0120 00, Item 58)

References

- See your -10
- See your -20

Materials/Parts

Kit P/N 5703656

Equipment Condition

- Engine stopped (see your -10)
 - Carrier blocked (see your -10)
-

INSTALLATION

NOTE

The positions of 10 screws, out of the 20 screws furnished in the kit, are measured from the line connecting POINT A and POINT B.

1. Locate and mark POINT A and POINT B on the left side of carrier, using dimensions given below.
2. Mark a line between POINT A and POINT B.

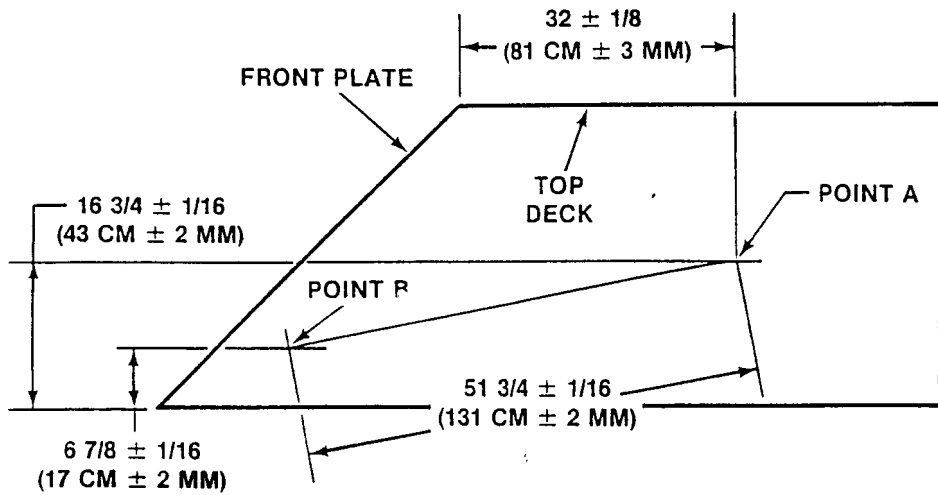
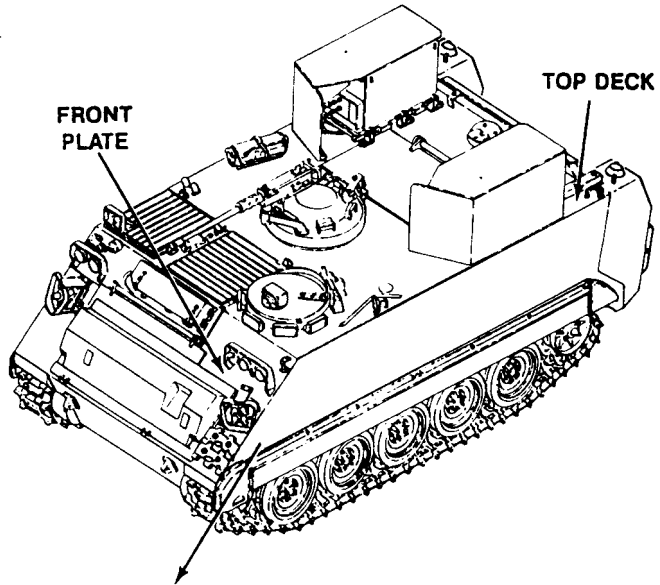

3. Measure and mark the center points for holes, using the dimensions given below.
4. Drill and tap the 10 holes marked in Step 3. Tap holes to 1/2-13 UNC-2B, 1 inch (3 cm) minimum full thread depth.

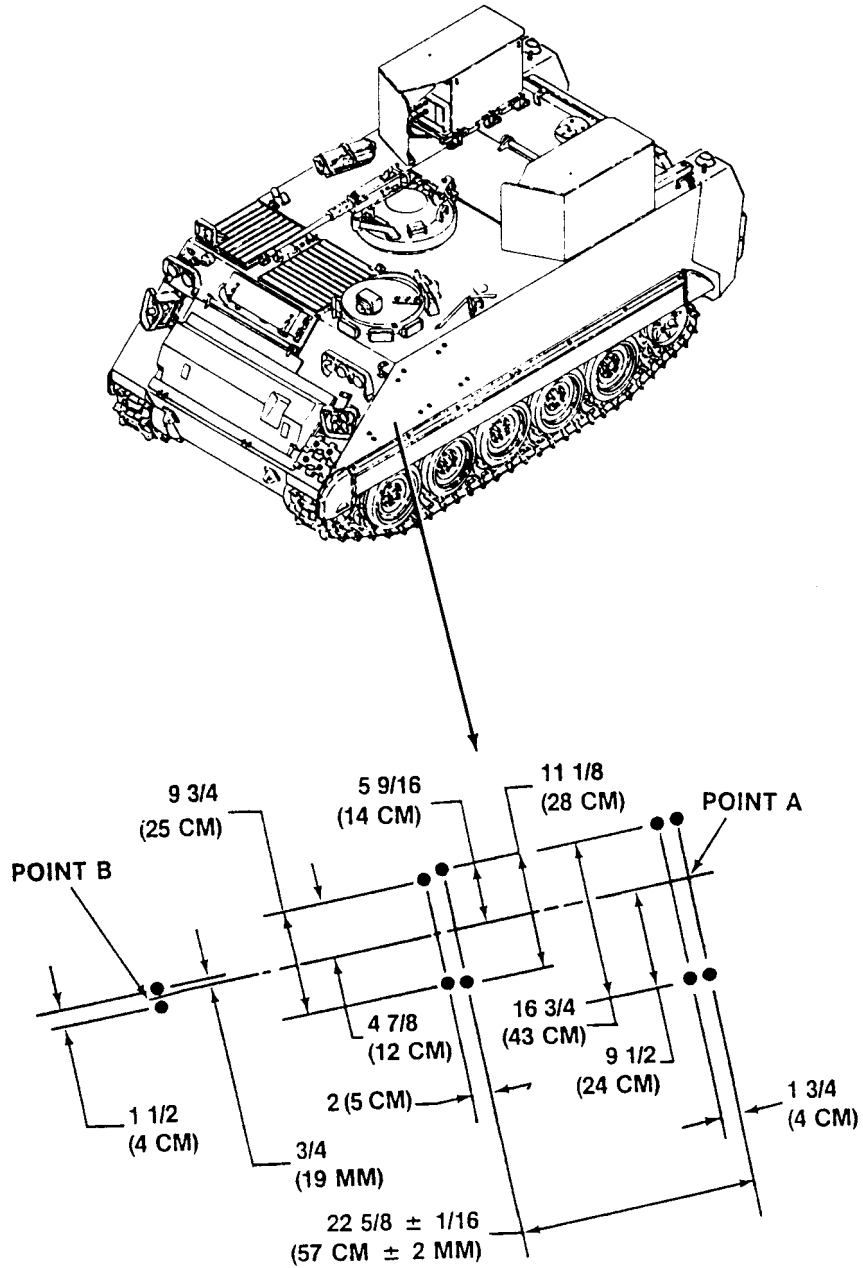

NOTE

The positions of the remaining 10 screws are measured from the line connecting POINT C and POINT D.

5. Locate and mark POINT C and POINT D on the left side of carrier, using dimensions given below.
6. Mark a line between POINT C and POINT D.

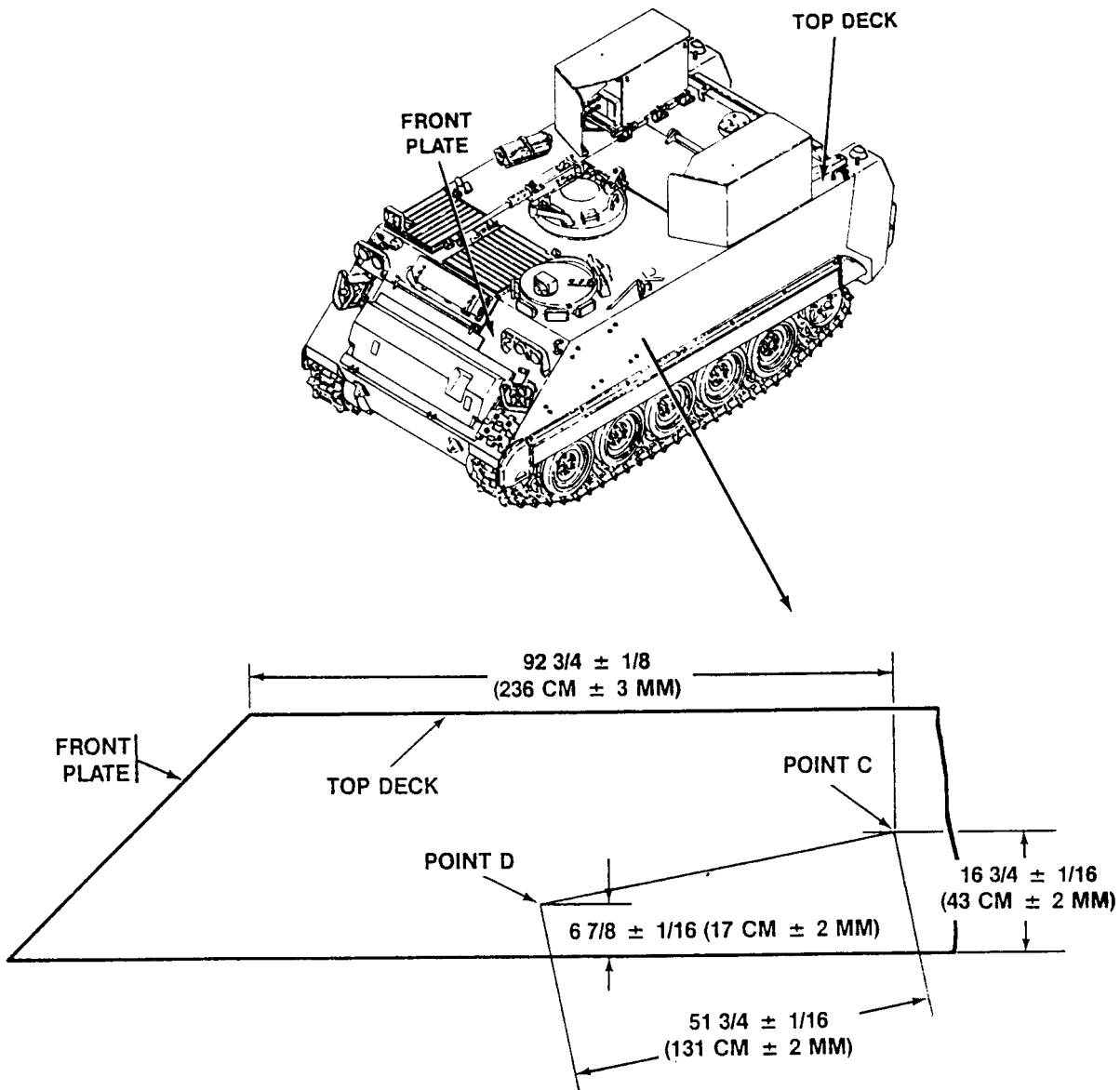

7. Measure and mark the center points for 10 holes, using the dimensions given below.
8. Drill and tap 10 holes as marked in Step 7. Tap holes to 1/2-13 UNC-2B, 1 inch (3 cm) minimum to 1 9/16 inch (4 cm) maximum full thread depth.

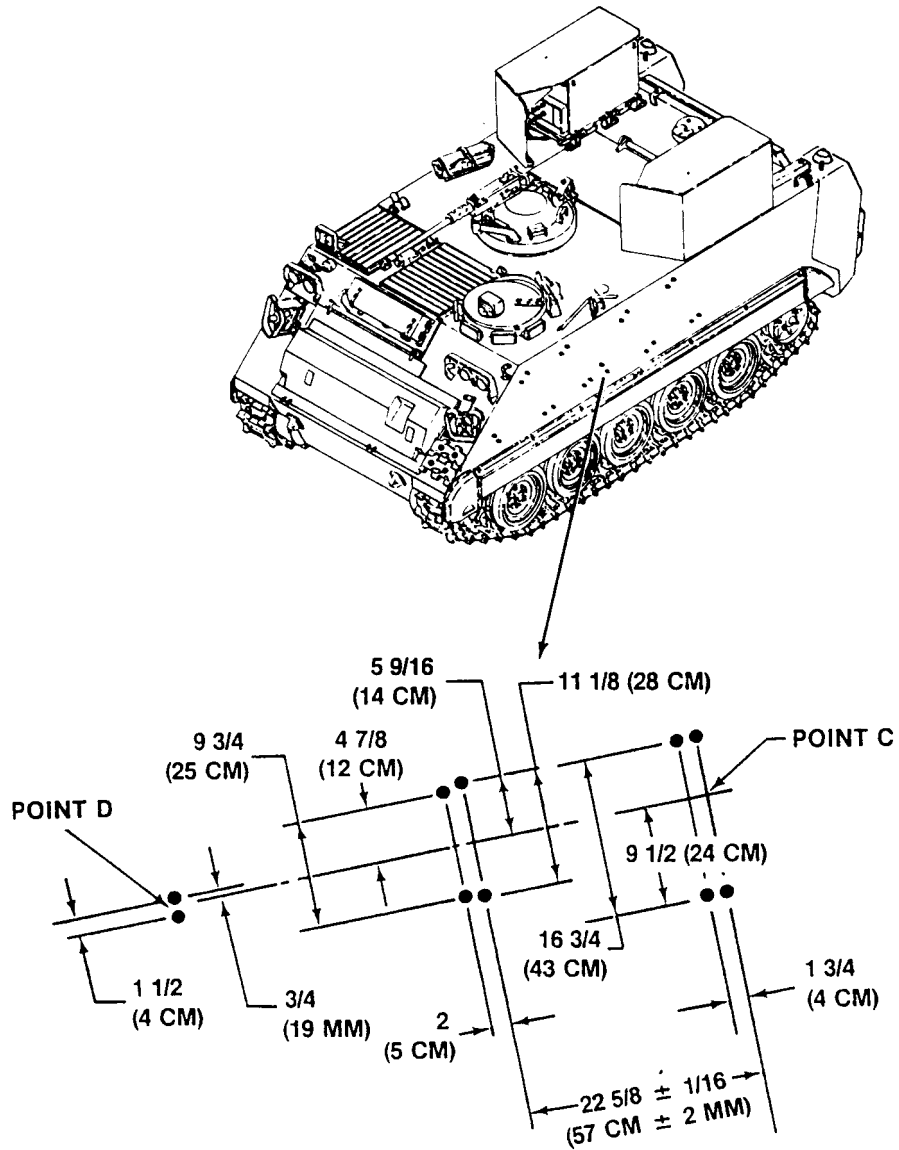

INSTALL ANCHOR KIT (M1059A3 ONLY) — Continued**0087 00**

9. Install two hook brackets (1) on carrier. Secure with four screws (2).
10. Install two hooks (3) on brackets (1). Secure with two spacers (4), square nuts (5), and wingnuts (6). Stake last two threads of hook to retain wingnuts.
11. Install two supports (7) on carrier. Secure with eight flat washers (8) and screws (9).
12. Install four angle brackets (10) on carrier. Secure with eight screws (11).

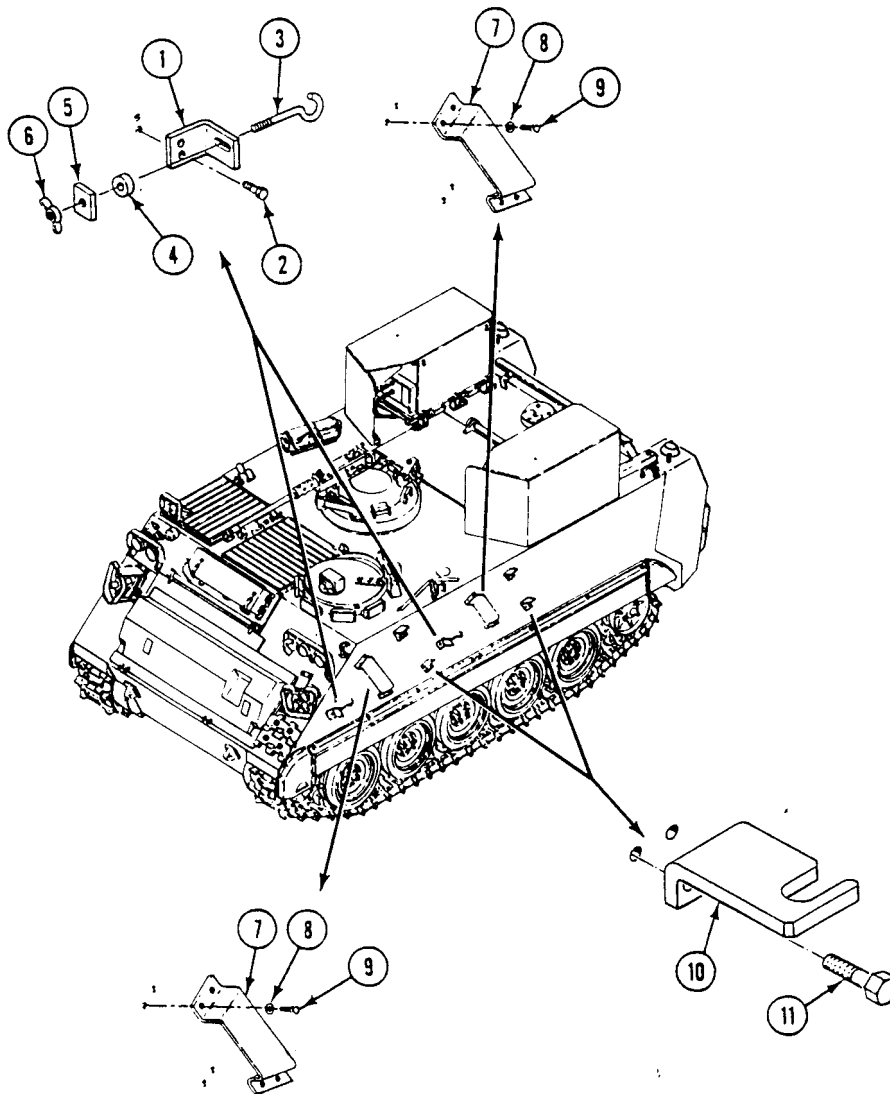

13. Remove two anchors (12) from the cables and toelines of anchor kit.

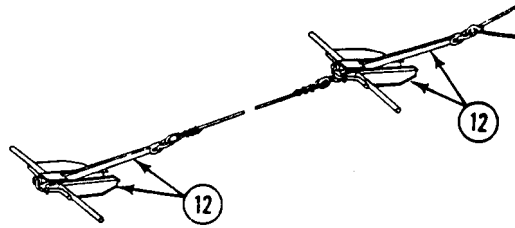

14. Slide two anchors (12) into supports (7) and brackets (10) on left side of carrier.
 15. Fasten two hooks (3) to anchors (12) and tighten wingnuts.

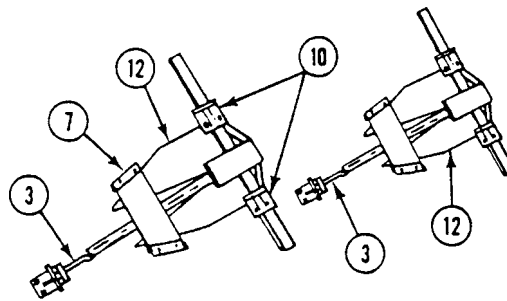

16. Place tarpaulin (1), four straps (2), and fid (3) on flat surface.
 17. Place two cable assemblies, six toelines, six shackles, and fid on tarpaulin (1).

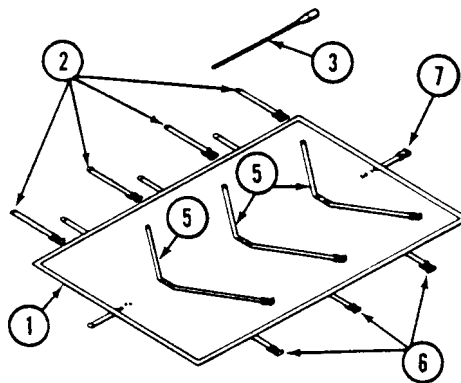

18. Fasten anchor kit items (4) on tarpaulin (1) with three straps (5) that are part of tarpaulin.

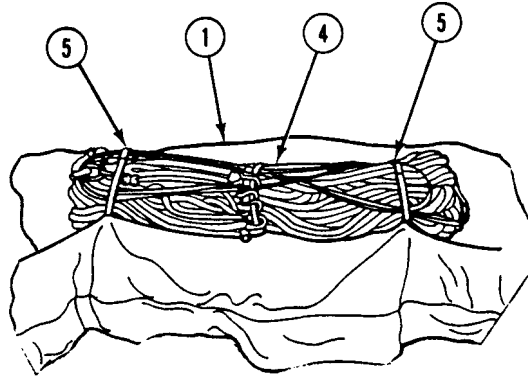

19. Wrap tarpaulin (1) over anchor kit items (4). Fasten tarpaulin together with three straps (6) and webbing (7) that are parts of tarpaulin. Use fid (rounded pin) to tuck towlines into tarpaulin.
20. Stow anchor kit on carrier as directed by local authority. Use four straps (2) to secure kit in place.

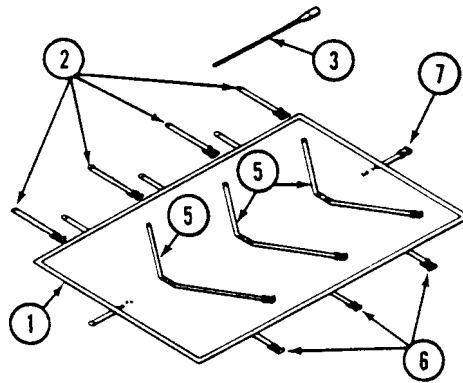

END OF TASK

INSTALL COMMANDER'S CUPOLA ARMOR SHIELDS (M113A3 AND M1064A3 ONLY)

0088 00

THIS WORK PACKAGE COVERS:

Installation (page 0088 00-1).

INITIAL SETUP:

Maintenance Level

Direct Support

Personnel Required

Track Vehicle Repairer 63H10

Helper (H)

Tools and Special Tools

General Mechanic's Tool Kit (WP 0120 00, Item 62)

Portable Electric Drill (WP 0120 00, Item 7)

Portable Electric Drill (WP 0120 00, Item 8)

Twist Drill Set (WP 0120 00, Item 10)

Twist Drill (WP 0120 00, Item 11)

Screw Threading Set (WP 0120 00, Item 58)

References

See your -10

TB 43-0209

TM 43-0139

Materials/Parts

Enamel (WP 0122 00, Item 12)

Primer Coating (WP 0122 00, Item 24)

Shield Kit P/N 11660854

Spacer, 1/16 to 1/8 inch thick (2)

Wood blocks of equal height (2)

Equipment Condition

Engine stopped (see your -10)

Carrier blocked (see your -10)

INSTALLATION

1. If four shield mounting holes are already drilled in cupola hatch, remove and discard four 1/2-13 screws and flat washers from hatch. If mounting holes are NOT drilled, follow Steps 3 - 5.
2. Remove two 5/8-18 screws (1) and washers (2) from outboard support legs of machine gun pintle (3). Discard screws. Keep flat washers.
3. Remove machine gun mount and support from cupola. Close cupola (see your -10).

NOTE

All dimensions are in inches with metric equivalents.

4. Measure and mark four points (A, B, C, and D) on cupola shown at right. Measure point positions from four existing screw holes that secure machine gun support to cupola.

INSTALL COMMANDER'S CUPOLA ARMOR SHIELDS (M113A3 AND M1064A3 ONLY) —
Continued

0088 00

5. Drill four holes using 27/64 (11 mm) drill. Drill to a maximum depth of 1-1/4 (3 cm). Tap with a 1/2-13 UNC tap to a minimum depth of 7/8 (22 mm).

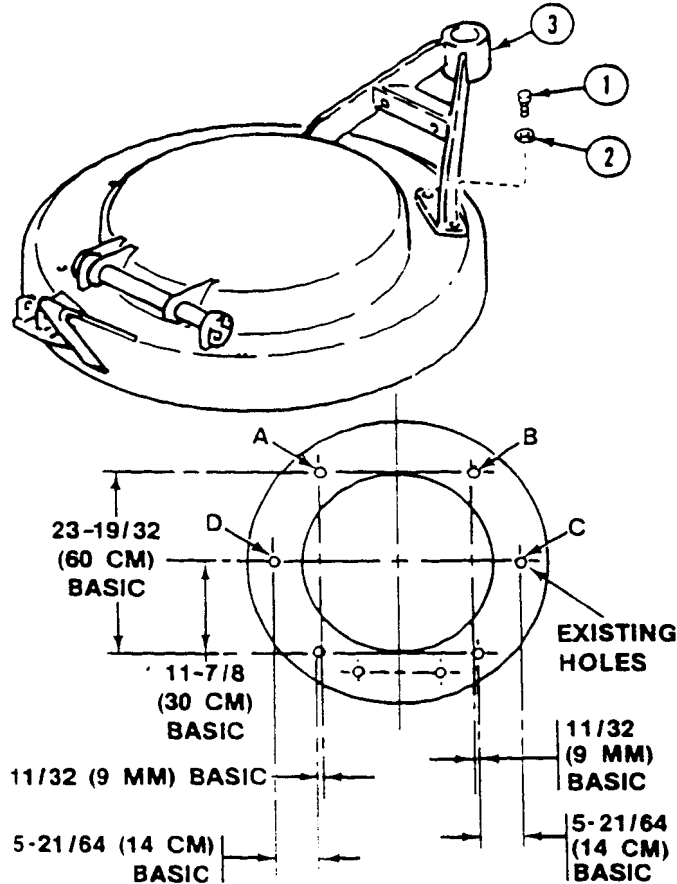

6. Remove locknut (1), two flat washers (2), and cap screw (3) that secure hook (4), spring (5), and two spacers (6) on cupola hatch. Discard hook. Keep all other parts.
7. Place new hook (4), spring (5), and two spacers (6) on cupola hatch. Secure with two flat washers (2), cap screw (3), and locknut (1).
8. Remove locknut (7) and flat washer (8) that secure bumper (9) and flat washers (10) to cupola hatch. Remove bumper and washers. Keep washers. Discard locknut.
9. Place new bumper extension bracket (11) on cupola hatch with welded end up. Secure with new cap screw (12), flat washer (13), and locknut (14).
10. Use flat washers (10), as needed, to compress bumper 1/4 inch (6 mm) when cover is open and latched. Place flat washers (10) and bumper (9) on bracket (11). Secure with flat washer (8) and new locknut (7).

NOTE

Gun shields are large and bulky. Get an assistant to help you.

11. Install curved doors (15) in guide channels of shields (16) and (17). There are two doors in each shield. Install four clips (18) to secure doors open. Deform clips to turn freely around loop on doors.

INSTALL COMMANDER'S CUPOLA ARMOR SHIELDS (M113A3 AND M1064A3 ONLY) —
Continued

0088 00

12. Place left and right shields (16) and (17) on cupola. Secure with two retained flat washers (19), two cap screws (20), four flat washers (21), four lockwashers (22), and four cap screws (23).
13. Remove two cap screws (24) and lockwashers (25) that secure plastic covered stop (26) on machine gun support. Remove stop. Discard stop, screws, and washers.
14. Place spacer (27) and bracket (28) on machine gun support. Secure with two machine screws (29).
15. Install flat door (30) in slots in bracket (28). Install four hooks (31). Close hooks to form a chain from loop on door to loop on bracket.

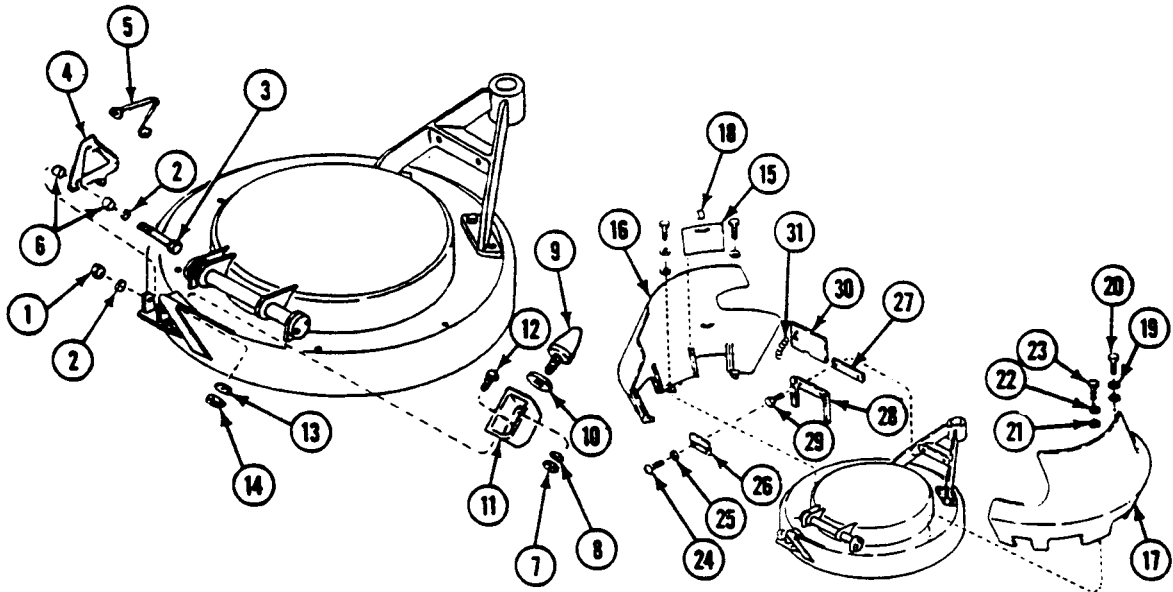

16. Place front armor shield (1) on a level surface with shield plate supported on two blocks (2) of equal height. Place blocks about 2 1/2 inches (6 cm) apart with hole in plate centered between blocks. Blocks must support pintle flange of machine gun mount.
17. Place machine gun mount (3) on shield plate (1). Install machine gun in mount. Center machine gun in shield slot.

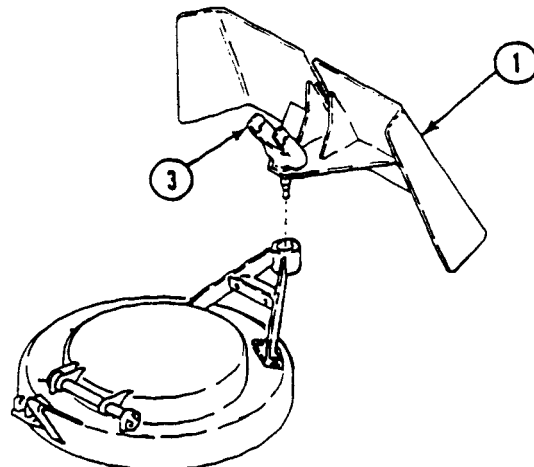

INSTALL COMMANDER'S CUPOLA ARMOR SHIELDS (M113A3 AND M1064A3 ONLY) —
Continued

0088 00

18. Place two 1/16 to 1/8 inch (2 to 3 mm) thick spacers (4) between blocks and shield plate so pintle flange is 1/16 to 1/8 inch (2 to 3 mm) below shield plate.

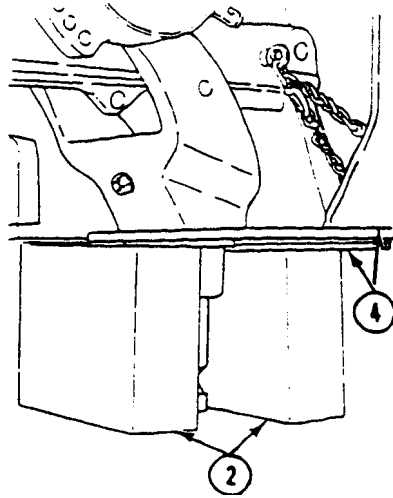

19. Using a level, check to see that pintle flange (3) and shield plate (1) are level. Make sure machine gun is still centered in slot. Remove machine gun.

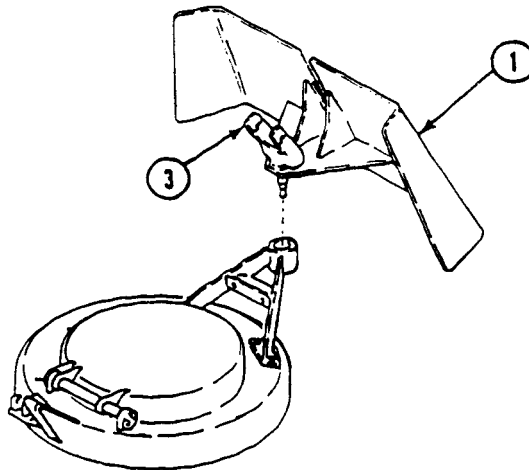

20. Use a welding machine and tack weld pintle flange to shield plate (1) in four places. Then weld pintle to upper surface on plate with not less than 3/16 inch (4 mm) fillet weld all around pintle flange. Weld in accordance with Class I, MIL-STD-1261.
21. Raise and lower machine gun mount. Check for interference between ammunition tray and shield plate. Use a hand grinder and grind off plate, as needed. Apply primer coating. See TM 43-0139.
22. Touch up any damaged areas with enamel paint. See TB 43-0209.

INSTALL COMMANDER'S CUPOLA ARMOR SHIELDS (M113A3 AND M1064A3 ONLY) —
Continued

0088 00

23. Install front shield (1) with machine gun pintle on cupola support. Install travel strap (5) and clamp (6) on right armor shield (7).

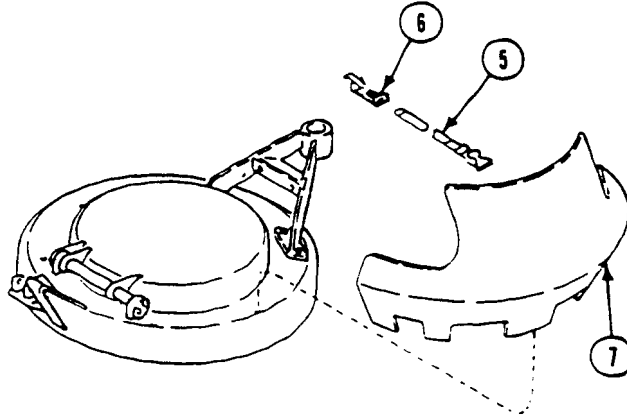
**END OF TASK**

CHAPTER 17
DELETED

WORK PACKAGE INDEX

<u>Title</u>	<u>Sequence No.</u>
DELETED.....	.0089 00

CHAPTER 18

DIRECT SUPPORT MAINTENANCE INSTRUCTIONS
FOR ELECTRICAL EQUIPMENT (M1068A3 ONLY)

WORK PACKAGE INDEX

<u>Title</u>	<u>Sequence No.</u>
REPLACE POWER CONTROL ENCLOSURE POWER SUPPLIES (M1068A3 ONLY).....	0090 00
REPAIR POWER CONTROL ENCLOSURE, LEFT PANEL (M1068A3 ONLY).....	0091 00
REPAIR POWER CONTROL ENCLOSURE, RIGHT PANEL (M1068A3 ONLY).....	0092 00
REPAIR POWER CONTROL ENCLOSURE, REAR PANEL (M1068A3 ONLY).....	0093 00
REPLACE/REPAIR INVERTER AND INVERTER HOUSING ASSEMBLY A2 (M1068A3 ONLY).....	0094 00
REPAIR POWER ENTRY BOX ASSEMBLY A4 (M1068A3 ONLY).....	0095 00
REPAIR TENT INTERFACE PANEL BOX ASSEMBLY A5 (M1068A3 ONLY).....	0096 00
REPAIR AC POWER EXTENSION BOXES A6 AND A7 (M1068A3 ONLY).....	0097 00
REPAIR ROADSIDE DC POWER EXTENSION BOX A9 (M1068A3 ONLY).....	0098 00
REPAIR SIGNAL PATCH PANEL BOX A10 (M1068A3 ONLY).....	0099 00
REPAIR EXTERNAL COMMUNICATION BOX A11 (M1068A3 ONLY).....	0100 00
REPAIR ROADSIDE AND CURBSIDE DATA PANEL ASSEMBLIES A12 AND A13 (M1068A3 ONLY).....	0101 00
REPAIR PHONE EXTENSION BOX A14 (M1068A3 ONLY).....	0102 00
REPAIR ROADSIDE AC POWER EXTENSION BOX A18 (M1068A3 ONLY).....	0103 00
REPAIR CURBSIDE AC POWER EXTENSION BOX A19 (M1068A3 ONLY).....	0104 00
REPLACE LAN A CABLE W101 AND/OR LAN B CABLE W102 (M1068A3 ONLY).....	0105 00
REPLACE RF 1, 2, 3, 4 CABLE ASSEMBLIES W111, W112, W113, AND W114 (M1068A3 ONLY).....	0106 00
REPLACE CABLE ASSEMBLY W115 (M1068A3 ONLY).....	0107 00
REPLACE CABLE ASSEMBLIES W117 AND W118 (M1068A3 ONLY).....	0108 00

REPLACE POWER CONTROL ENCLOSURE POWER SUPPLIES (M1068A3 ONLY)

0090 00

THIS WORK PACKAGE COVERS:

Removal (page 0090 00-1).
 Installation (page 0090 00-4).

INITIAL SETUP:

Maintenance Level

Direct Support

Personnel Required

Power-Generation Equipment Repairer 52D10
 Helper (H)

Tools and Special Tools

General Mechanic's Tool Box (WP 0120 00, Item 62)

References

See your -10
 See your -20

Materials/Parts

Lockwasher (4)
 Lockwasher (8)
 Lockwasher (12)
 Locknut (16)
 Strap

Equipment Condition

Power control enclosure assembly
 removed (see your -20)

REMOVAL

1. Remove 12 screws (1), lockwashers (2), and cover (3) from enclosure (4). Discard lockwashers.
2. Remove four screws (5) and lockwashers (6) connecting power supply (7) to bracket (8). Discard lockwashers.

REPLACE POWER CONTROL ENCLOSURE POWER SUPPLIES (M1068A3 ONLY) —
Continued

0090 00

- Remove four screws (5) and lockwashers (6) connecting power supply (9) to bracket (8). Discard lockwashers.

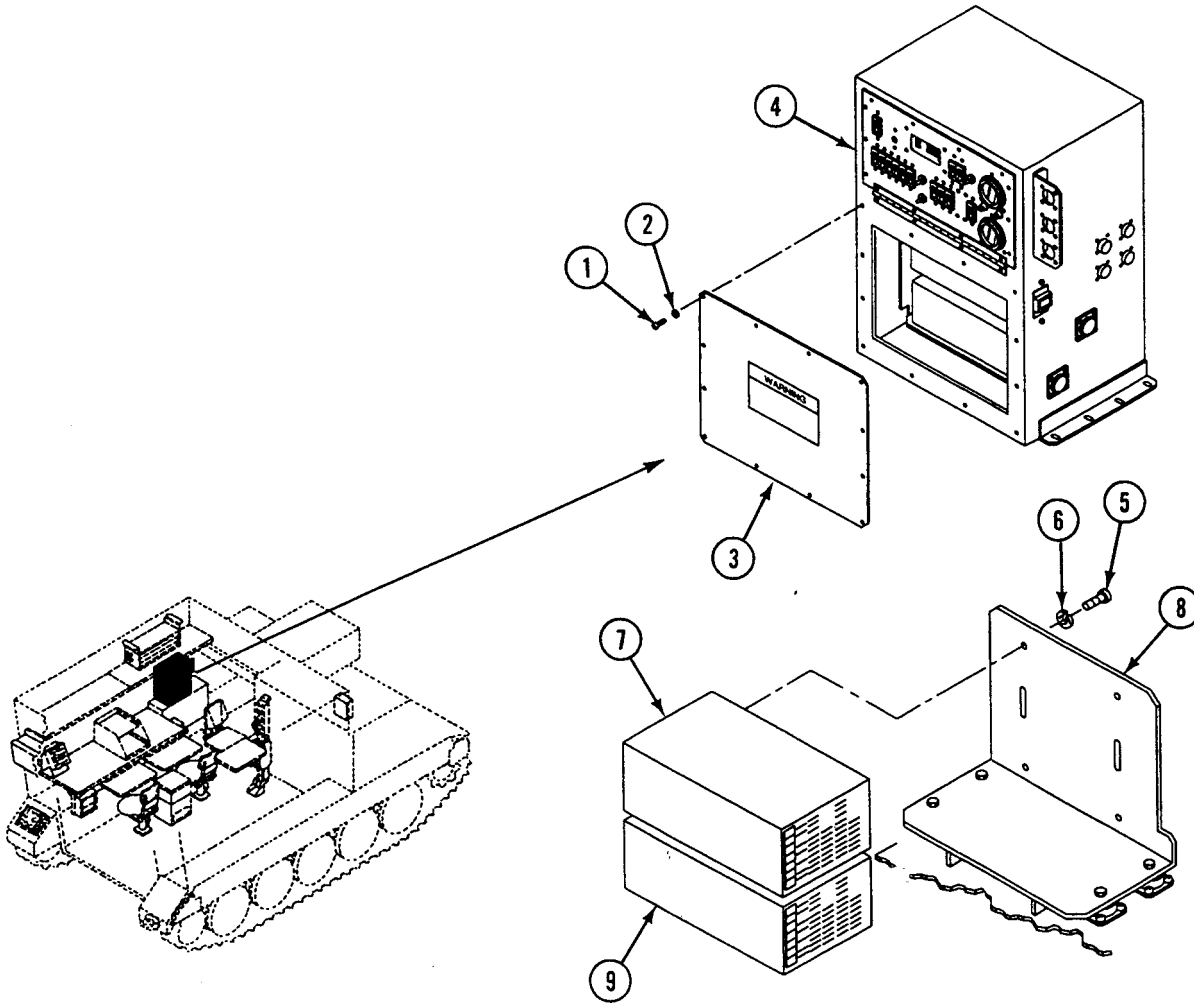

REPLACE POWER CONTROL ENCLOSURE POWER SUPPLIES (M1068A3 ONLY) —
Continued

0090 00

NOTE

Tag all leads before disconnecting from terminals.

4. Remove four nuts (1) and five leads (2) from two power supplies (3) and (4).
5. Disconnect jumper cable (5) from two power supplies (3) and (4).
6. Remove three screws (6) and four leads (7) from power supply (3). Lift power supply (3) from enclosure, have helper assist.
7. Remove three screws (8) and five leads (9) from power supply (4). Lift power supply from enclosure, have helper assist.
8. Remove four screws (10), lockwashers (11), and bracket (12) from four isolators (13). Discard lockwashers.
9. Remove 16 locknuts (14), screws (15), and four isolators (13) from enclosure (16). Discard locknuts.

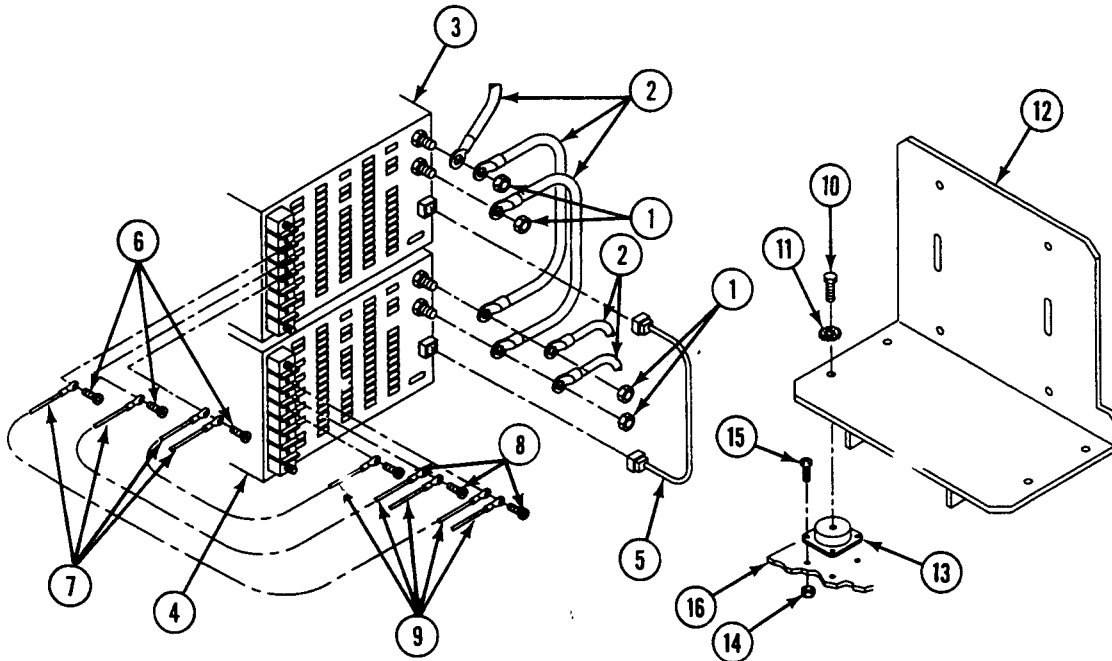

REPLACE POWER CONTROL ENCLOSURE POWER SUPPLIES (M1068A3 ONLY) —
Continued

0090 00

INSTALLATION

1. Install four isolators (13), 16 screws (15), and new locknuts (14) in enclosure (16).
2. Install bracket (12), four new lockwashers (11), and screws (10) on four isolators (13).
3. Lift power supply (4) into enclosure, have helper assist. Install circuits 10A and 10B leads with screw (8) on AC HIGH terminal of power supply (4).
4. Install circuits 8B and 8C leads with screw (8) on AC LOW terminal of power supply (4).
5. Install circuit 3Z lead with screw (8) on GND terminal of power supply (4).
6. Lift power supply (3) into enclosure, have helper assist. Install circuit 10B lead with screw (6) on AC HIGH terminal of power supply (3).
7. Install circuit 8C lead with screw (6) on AC LOW terminal of power supply (3).
8. Install circuits 3Z and 3Y leads with screw (6) on GND terminal of power supply (3).

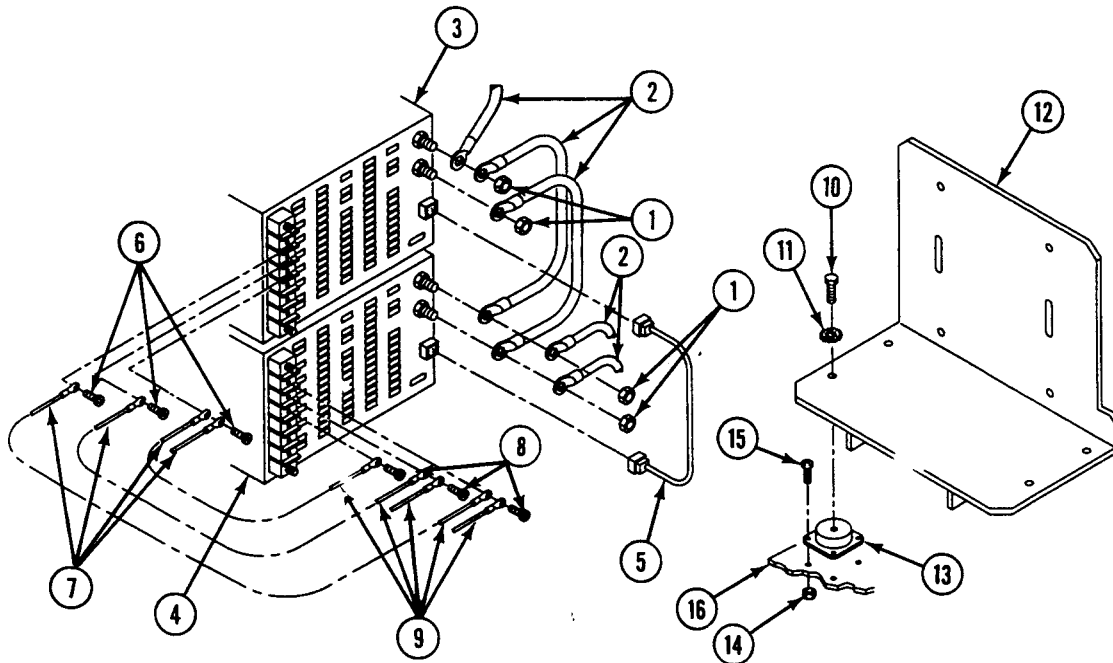

REPLACE POWER CONTROL ENCLOSURE POWER SUPPLIES (M1068A3 ONLY) —
Continued

0090 00

9. Connect jumper cable (1) to J1 on power supply (2) and J1 on power supply (3).
10. Connect circuits 31E and 31D (4) leads with nut (5) to positive terminal of power supply (2).
11. Connect circuits 31C (6) and 31D (4) leads with nut (5) to positive terminal of power supply (3).
12. Connect circuits 32D and 32E (7) leads with nut (5) to negative terminal on power supply (3).

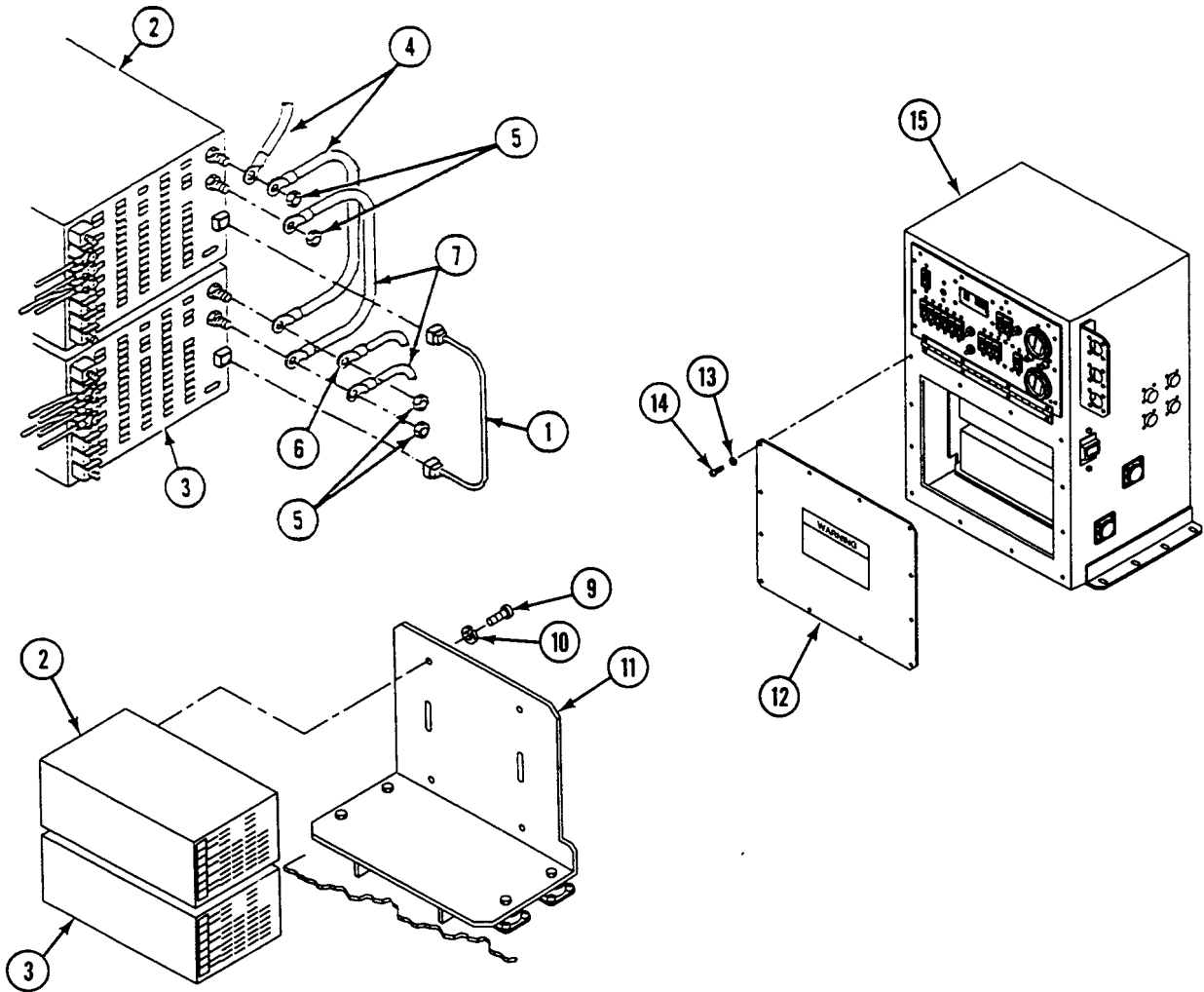

REPLACE POWER CONTROL ENCLOSURE POWER SUPPLIES (M1068A3 ONLY) —

0090 00

Continued

13. Connect circuit 32D (7) with nut (5) to negative terminal of power supply (2).
14. Secure power supply (2) with four screws (9) and new lockwashers (10) on bracket (11).
15. Secure power supply (3) with four screws (9) and new lockwashers (10) on bracket (11).
16. Install cover (12) on enclosure (15). Secure with 12 new lockwashers (13) and screws (14).

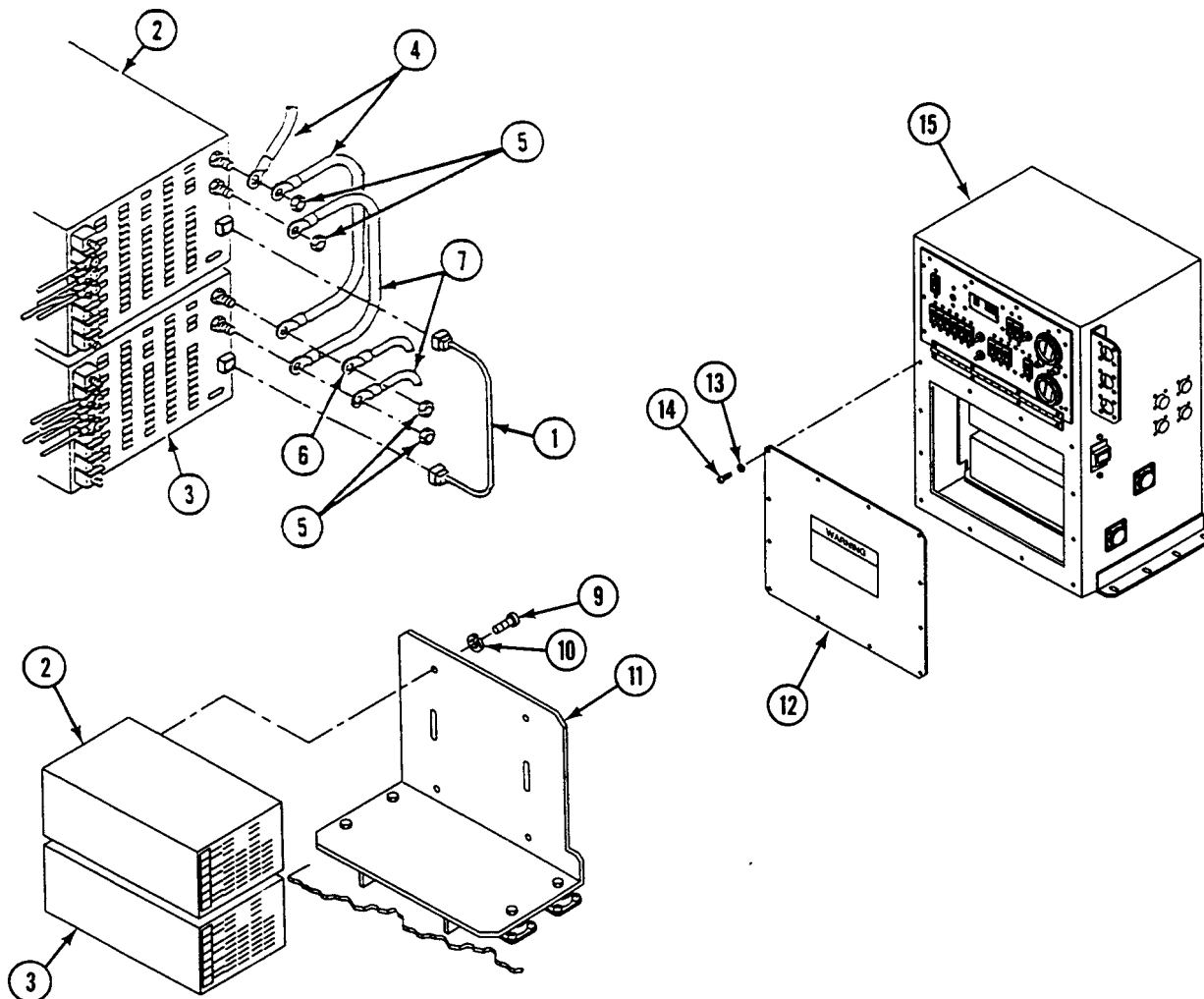

FOLLOW-THROUGH STEPS

1. Install power control enclosure assembly (See your -20).

END OF TASK

REPAIR POWER CONTROL ENCLOSURE, LEFT PANEL (M1068A3 ONLY)

0091 00

THIS WORK PACKAGE COVERS:

Disassembly (page 0091 00-1).
 Assembly (page 0091 00-5).

INITIAL SETUP:

Maintenance Level

Direct Support

References

See your -10
 See your -20

Tools and Special Tools

General Mechanic's Tool Kit (WP 0120 00, Item 62)

Equipment Condition

Power control enclosure assembly
 removed (see your -20).

Materials/Parts

Locknut (40)
 Lockwasher (10)
 Strap

Personnel Required

Power-Generation Equipment Repairer 52D10

DISASSEMBLY

1. Remove ten screws (11), lockwashers (12), and lower faceplate (9) from enclosure (10). Discard lockwashers.
2. Remove two screws (5), locknuts (6), four washers (7), relay bail (3), relay XK2 (2), and relay socket (1) from left panel (4). Discard locknuts.
3. Unplug relay socket (1) from relay XK2 (2).

4. Remove straps (8) from wires as required. Discard straps.

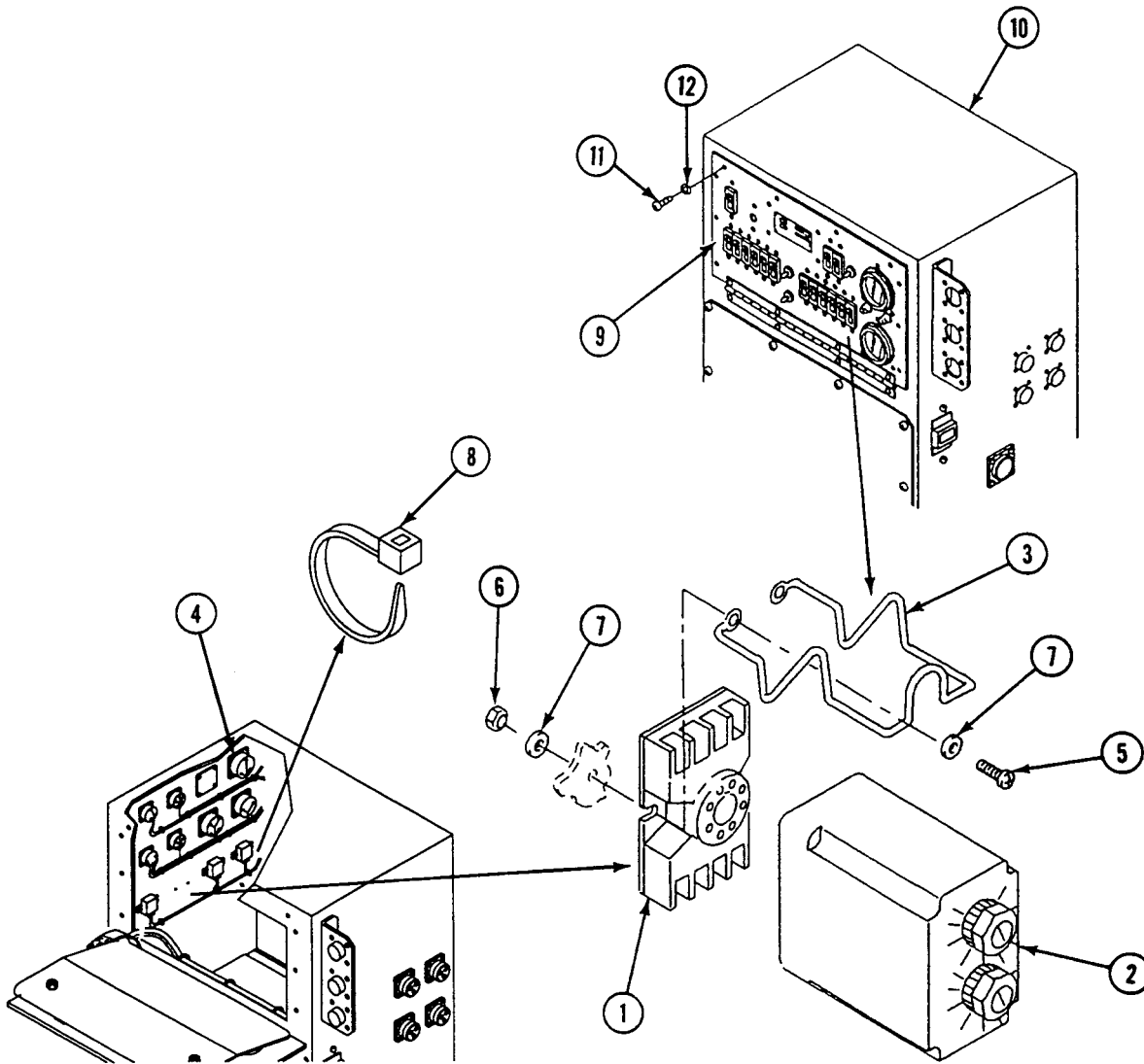

NOTE

Tag all leads/wires before removal for proper installation later.

See wiring diagram for disassembly/assembly of wires/leads.

5. Remove six screws (12), lockwashers (13), and eight circuit leads (10) from terminals of relay XK2 socket (11).
6. Remove two screws (5), locknuts (6), washers (7), and relay XK5 (9) from left panel (4). Discard locknuts.
7. De-solder/remove four wires (1) from terminals (2) of relay XK5 (9).
8. Remove two screws (5), locknuts (6), washers (7), and relay XK3 (8) from left panel (4). Discard locknuts.
9. De-solder/remove five wires (1) from terminals (2) of relay XK3 (8).
10. Remove two screws (5), locknuts (6), washers (7), and relay XK4 (3) from left panel (4). Discard locknuts.
11. De-solder/remove four wires (1) from terminals (2) of relay XK4 (3).

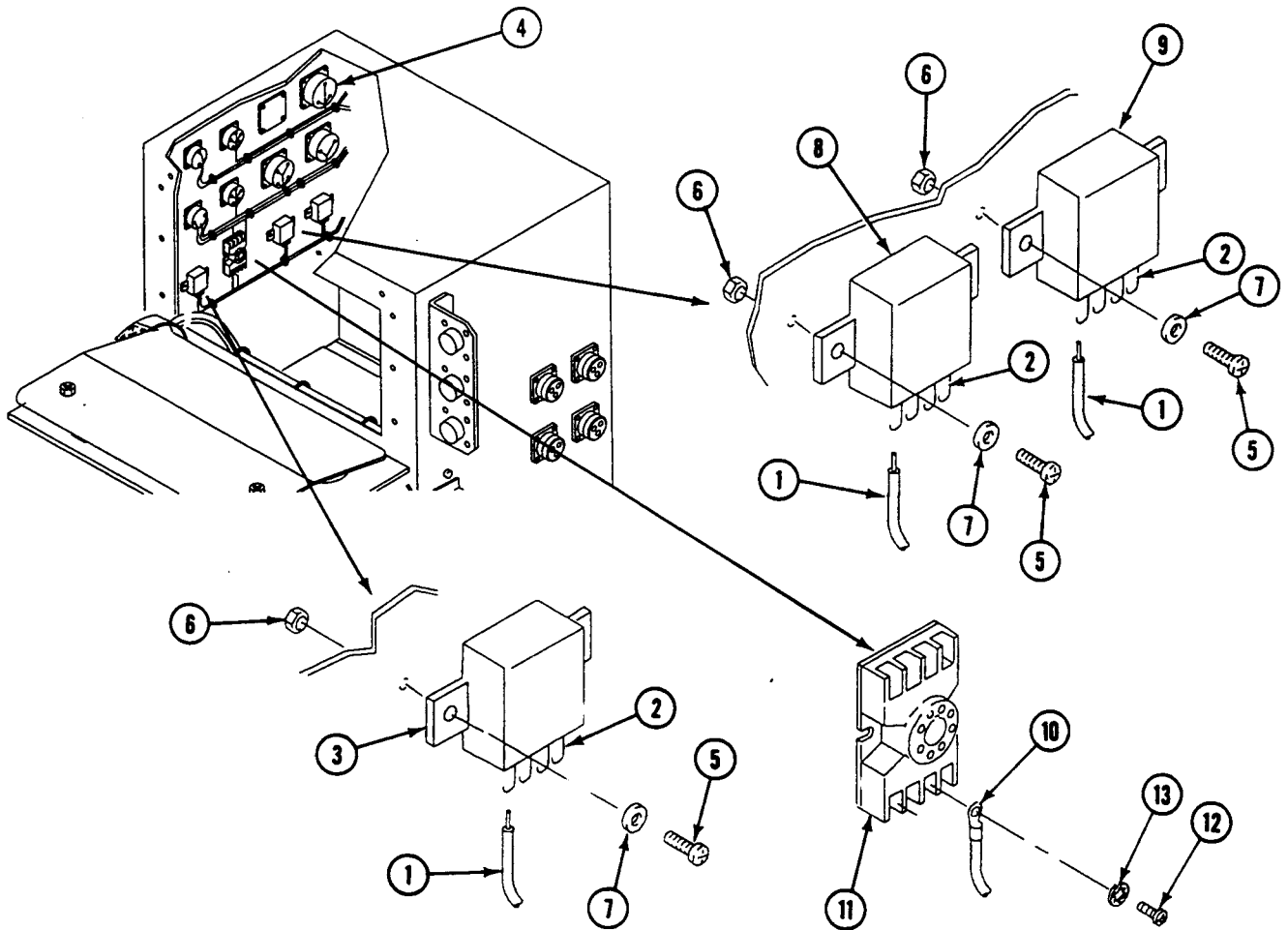

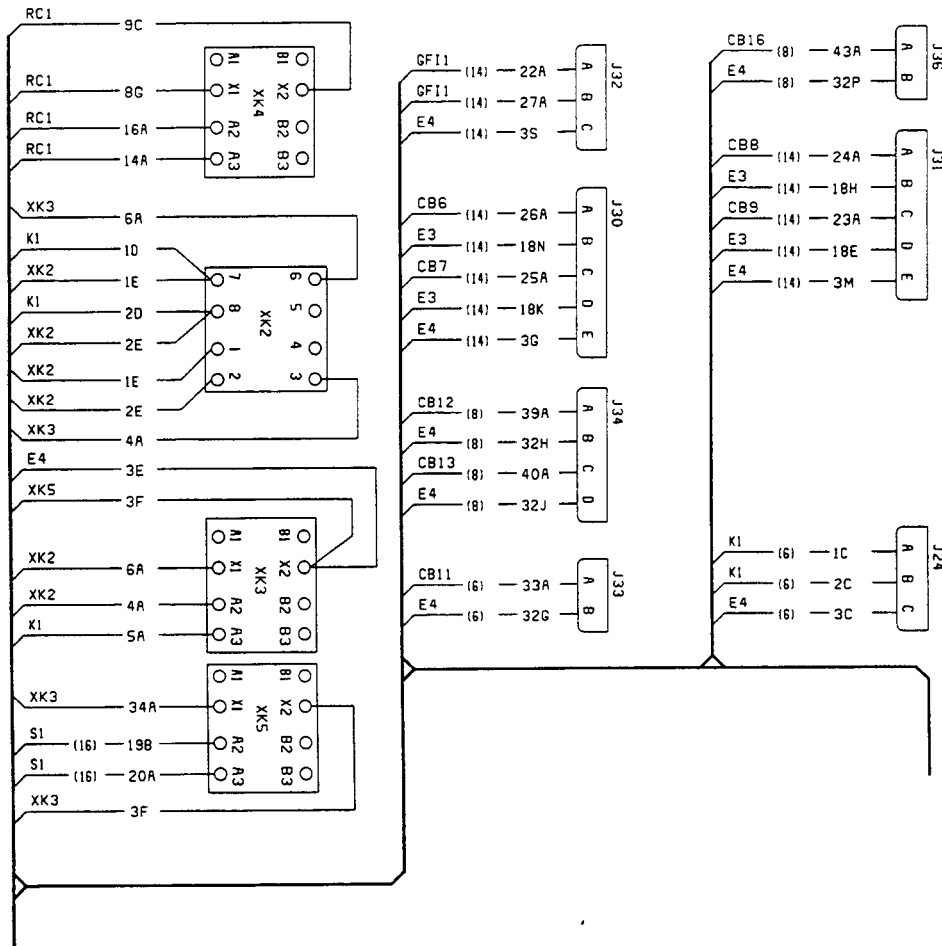

12. Remove straps (1) from wires as required. Discard straps.
13. Remove sixteen screws (2), locknuts (3), four connectors J24 (4), J31 (5), and J36 (6) from left panel (7). Discard locknuts.
14. Remove sixteen screws (2), locknuts (3), and four connectors J30 (8), J32 (9), J33 (10), and J34 (11) from left panel (7). Discard locknuts.
15. Remove/de-solder twenty eight wires (12) from terminals of connectors. See wiring diagram.

ASSEMBLY

1. Solder/install twenty-eight wires (12) on terminals of connectors. See wiring diagram.
2. Install four connectors J30 (8), J32 (9), J33 (10), and J34 (11) on left panel (7), secure with sixteen screws (2) and new locknuts (3).
3. Install four connectors J24 (4), J31 (5), and J36 (6) on left panel (7), secure with sixteen screws (2) and new locknuts (3).
4. Install new straps (1) on wires as required.

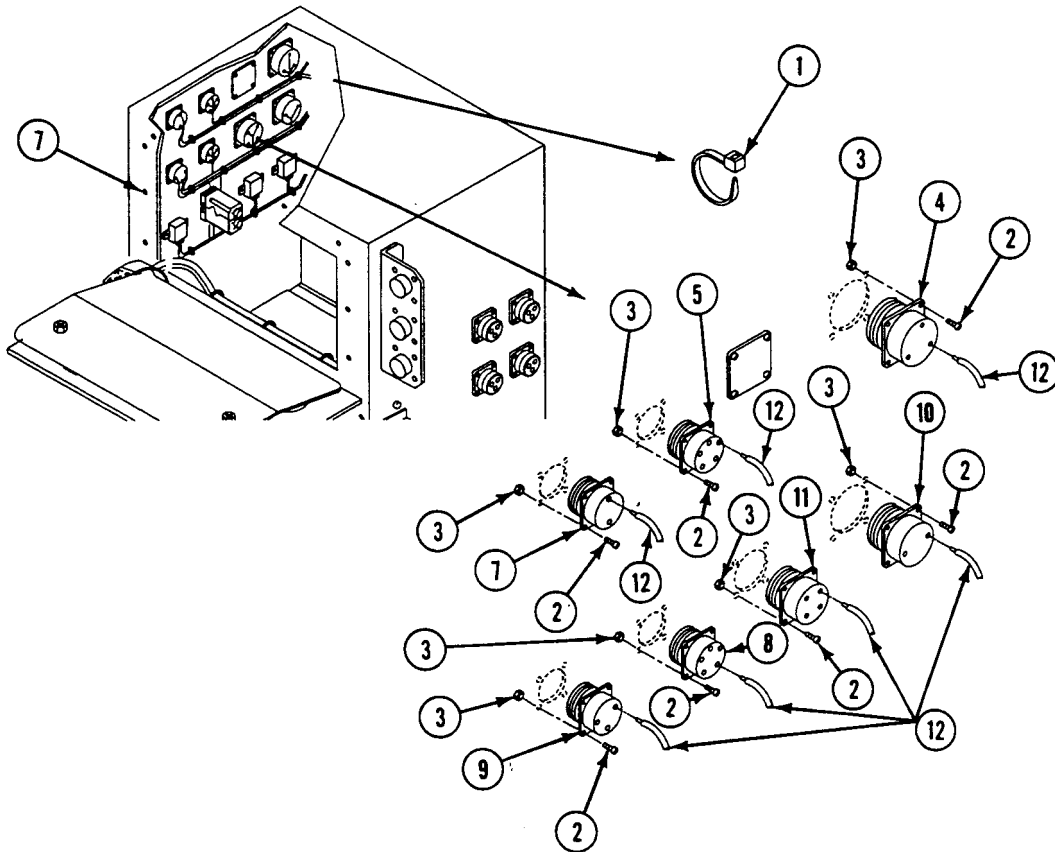

NOTE

See wiring diagram for disassembly/assembly of wires/leads.

5. Solder/install four wires (1) on terminals (2) of relay XK4 (3).
6. Install relay XK4 (3) on left panel (4), secure with two screws (5), new locknuts (6), and washers (7).
7. Solder/install five wires (1) on terminals (2) of relay XK3 (8).
8. Install relay XK3 (8) on left panel (4), secure with two screws (5), new locknuts (6), and washers (7).
9. Solder/install four wires (1) on terminals (2) of relay XK5 (9).
10. Install relay XK5 (9) on left panel (4), secure with two screws (5), new locknuts (6), and washers (7).
11. Install eight circuit leads (10) on terminals of relay socket (11), secure with six screws (12) and lockwashers (13).

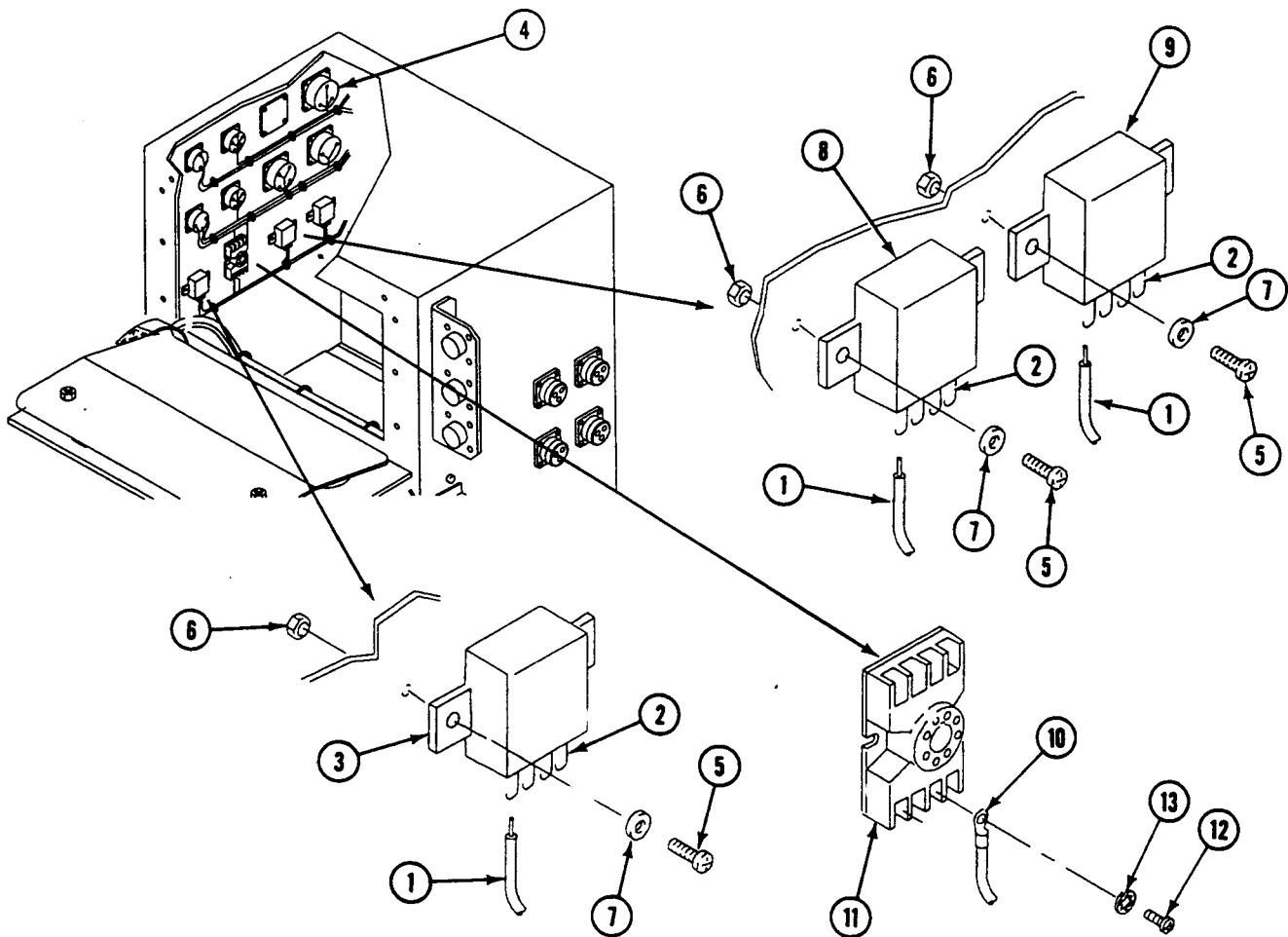

12. Plug relay socket (1) in relay XK2 (2).
13. Install relay bail (3) over relay XK2 (2), and relay socket (1) on left panel (4) and secure with two screws (5), new locknuts (6), and four washers (7).
14. Install new straps (8) on wires as required.
15. Close/install faceplate (9) on enclosure (10), secure with ten screws (11) and new lockwashers (12).

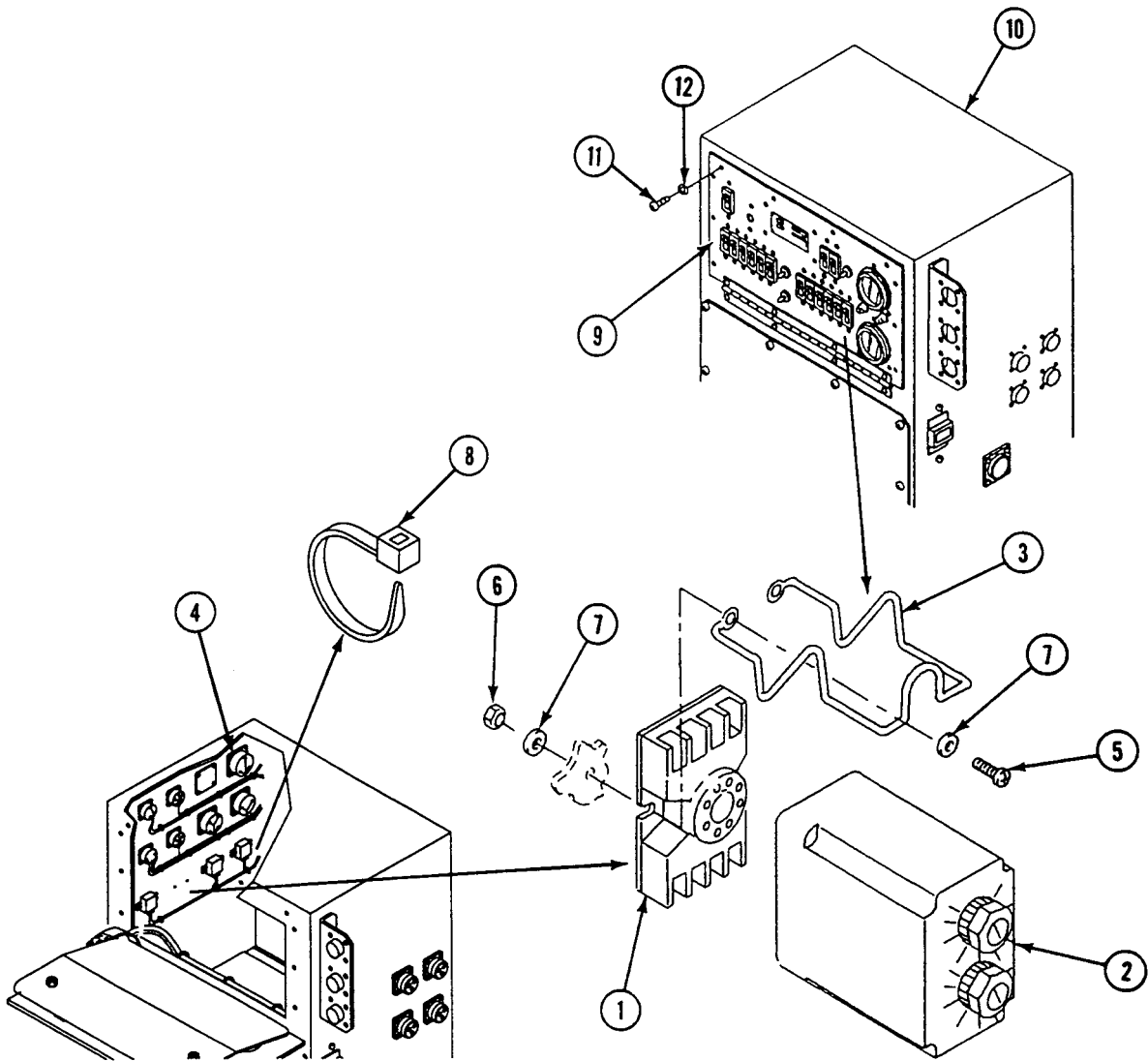

FOLLOW-THROUGH STEPS

1. Install power control enclosure assembly (see your -20).

END OF TASK

REPAIR POWER CONTROL ENCLOSURE, RIGHT PANEL (M1068A3 ONLY)

0092 00

THIS WORK PACKAGE COVERS:

Disassembly (page 0092 00-1).
 Assembly (page 0092 00-6).

INITIAL SETUP:

Maintenance Level

Direct Support

Personnel Required

Power-Generation Equipment Repairer 52D10
 Helper (H)

Tools and Special Tools

General Mechanic's Tool Kit (WP 0120 00, Item 62)

References

See your -10
 See your -20

Materials/Parts

Locknut (16)
 Locknut (8)
 Locknut (4)
 Lockwasher (12)
 Lockwasher (10)
 Lockwasher (8)
 Lockwasher (2)

Equipment Condition

Power control enclosure assembly
 removed (see your -20)

DISASSEMBLY

1. Remove 12 screws (1), lockwashers (2), and cover (3) from enclosure (4). Discard lockwashers.
2. Remove eight screws (5) and lockwashers (6) connecting power supplies (7) to bracket (8) and shift (move or slide) power supplies (7) to the left. Discard lock washers. Have Helper assist.

3. Remove 10 screws (9) and lockwashers (10) from faceplate (11). Lower faceplate. Discard lockwashers.

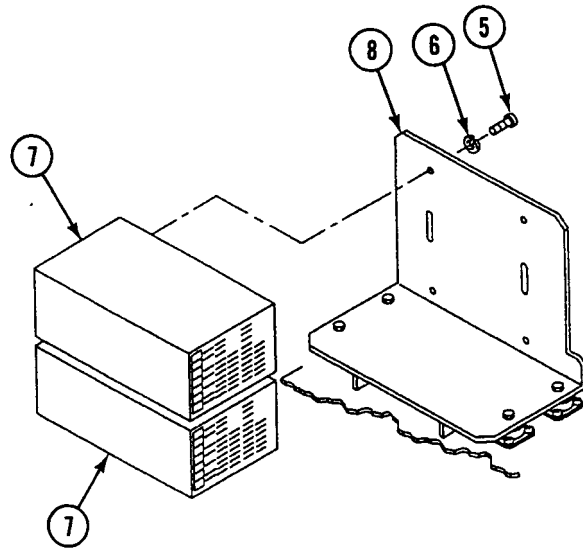
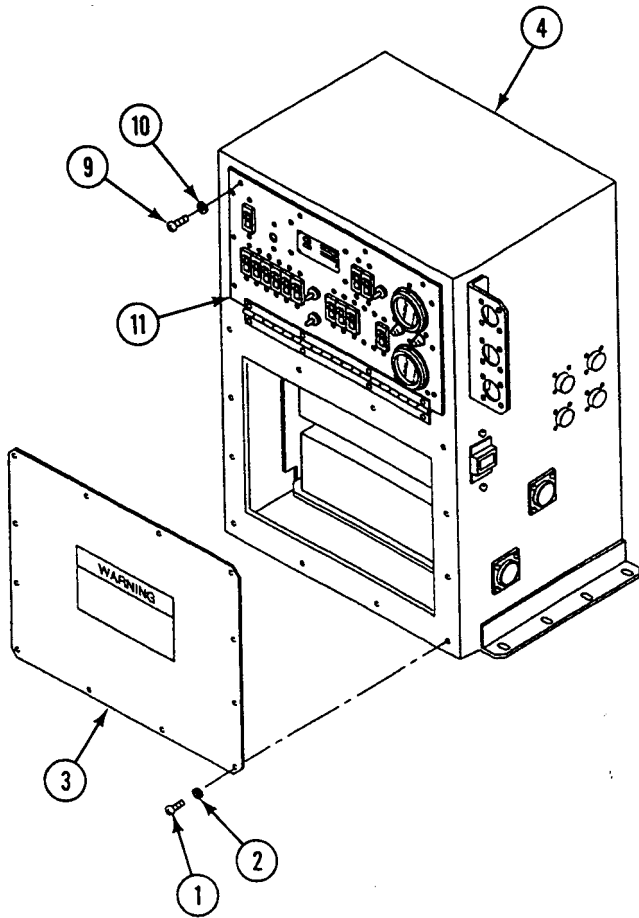

NOTE

Tag all leads and cables before removal.

4. Remove screw (1), lockwasher (2), and circuit 31A lead (3) from positive terminal of connector J25 (4).
5. Remove screw (5), lockwasher (6), and circuit 32E lead (7) from negative terminal of connector J25 (4).
6. Remove screw (8), lockwasher (9), and circuit 36C lead (10) from positive terminal of connector J26 (11).
7. Remove screw (12), lockwasher (13), and circuit 32C lead (14) from negative terminal of connector J26 (11).
8. Remove eight screws (15), locknuts (16), two dust caps (17), connector J25 (4), and connector J26 (11) from enclosure (18). Discard locknuts.
9. Remove circuit leads 20B, 18D, and 3AC (19) from connector J37 (20).

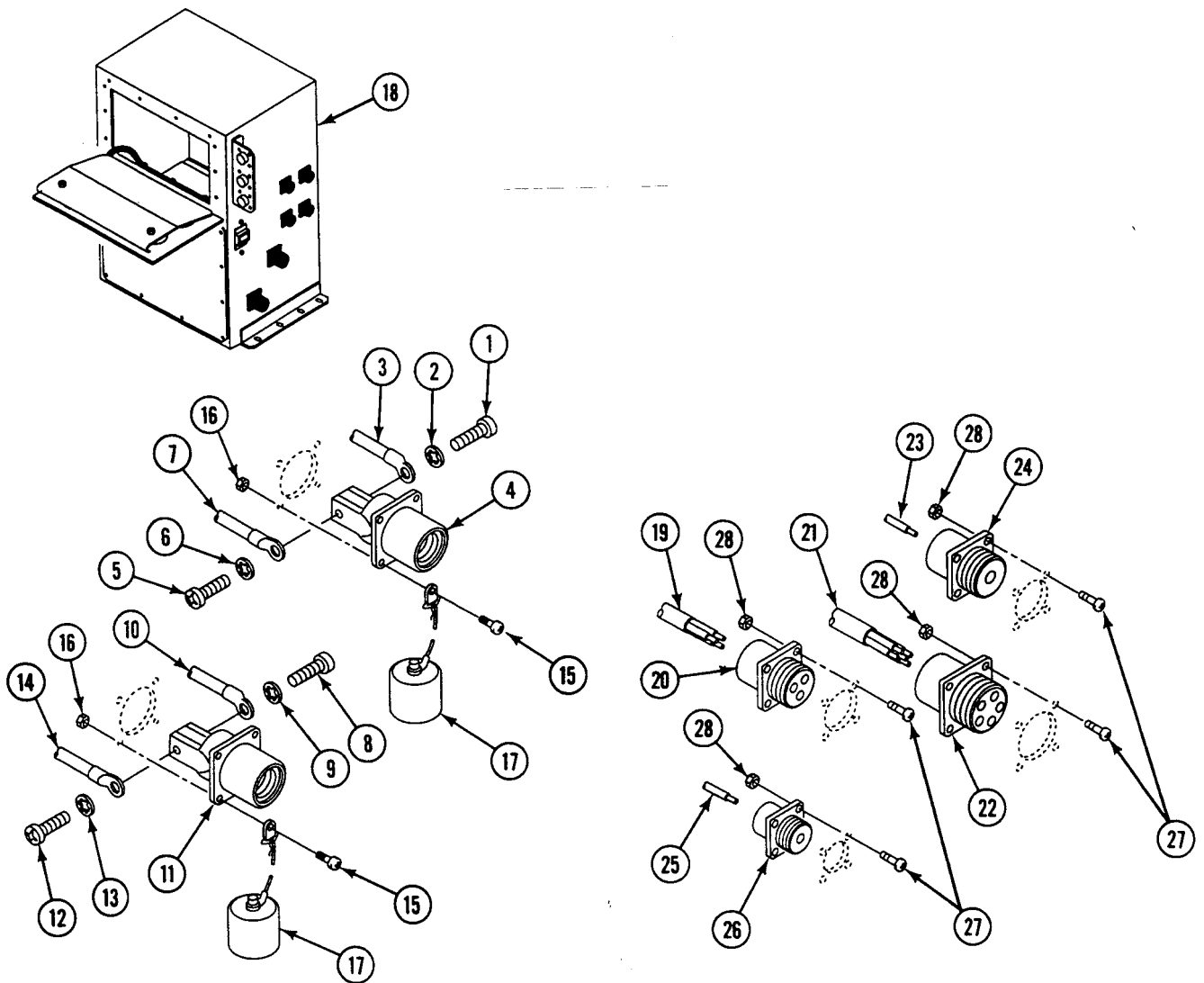

10. Remove circuit leads 11A, 28A, 12A, 28B, and 3W (21) from J27 (22).
11. Remove circuit lead 44A (23) from J28 (24).
12. Remove circuit 34A (25) from J29 (26).
13. Remove 16 screws (27), locknuts (28), and connectors J37 (20), J27 (22), J28 (24), and J29 (26) from enclosure (18). Discard locknuts.

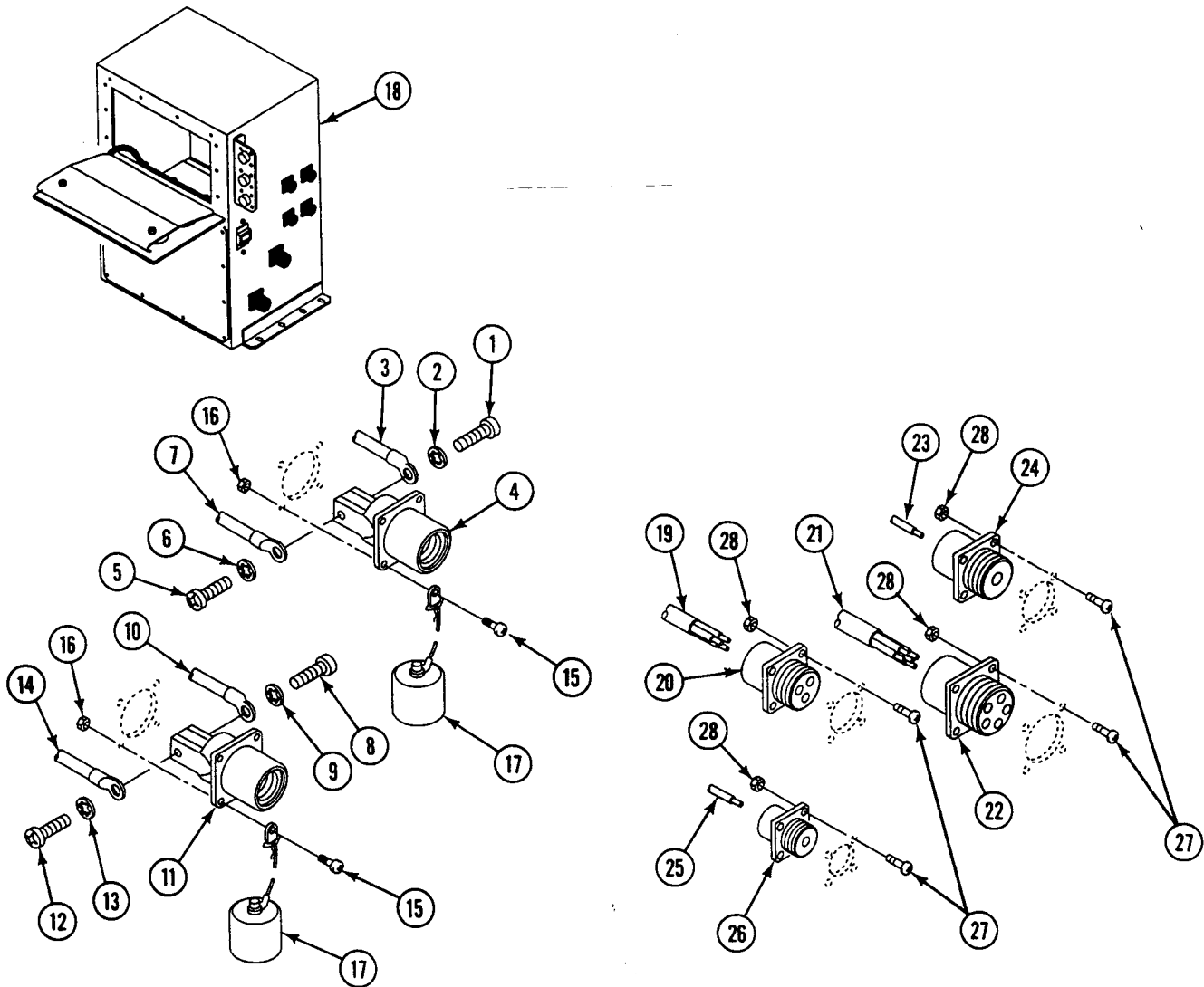

14. Remove circuit leads 22A, 21A, 3AA, 18C, and 27A (1) from ground fault interrupter (2). Remove two screws (3), lockwashers (4), and ground fault interrupter (2) from enclosure (5). Discard lockwashers.

NOTE

See wiring diagram to disconnect wires from terminal blocks. There are set screws securing each wire.

15. Remove all wiring from terminal blocks (6) by loosening all set screws. Remove four screws (7), locknuts (8), eight washers (9), and two terminal blocks (6) from enclosure (5). Discard locknuts.

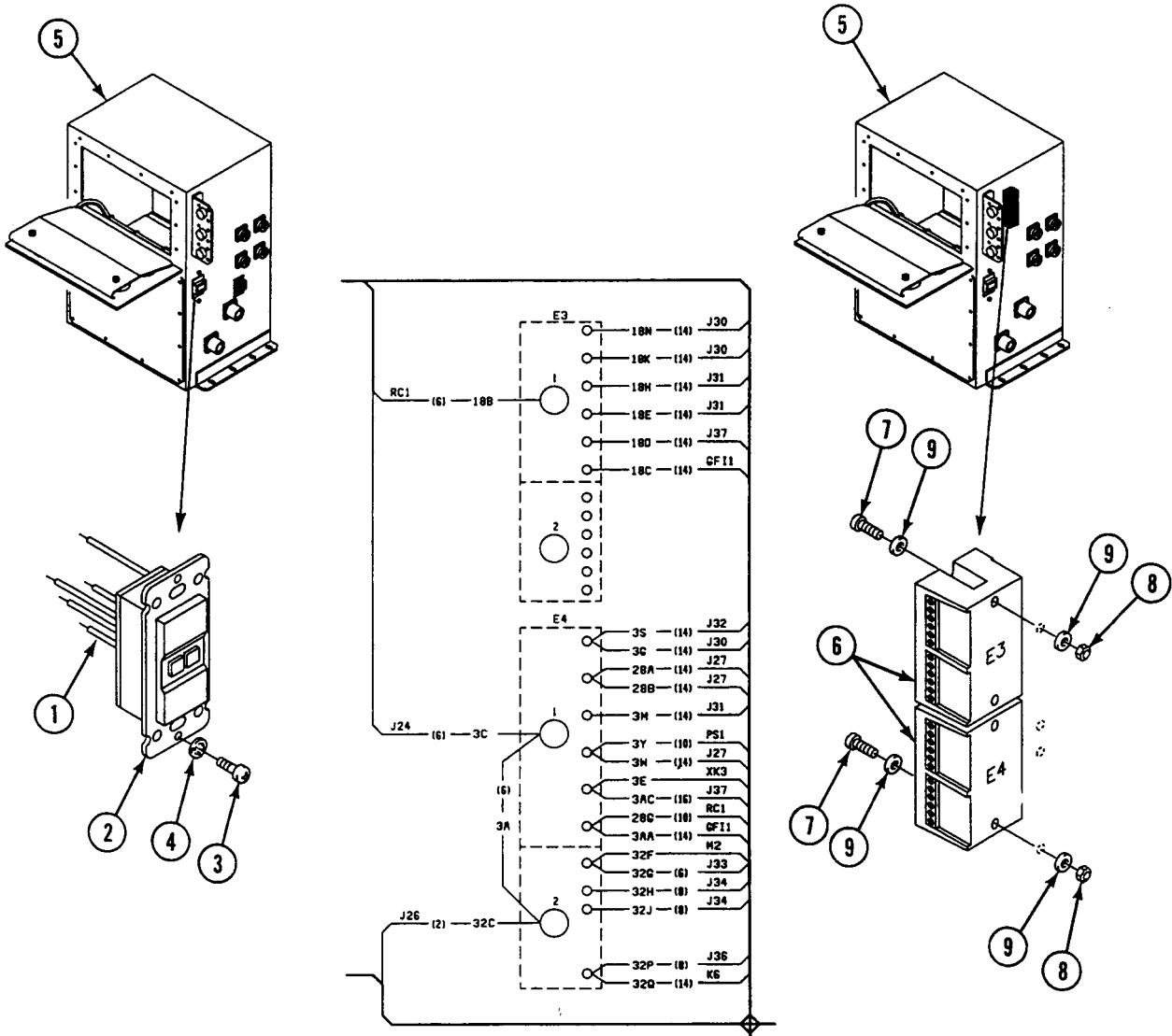

ASSEMBLY

1. Install two terminal blocks (6), four screws (7), new locknuts (8), and eight washers (9) on enclosure (5). Use wiring diagram. Install all wiring to terminal blocks and secure all set screws.
2. Install ground fault interrupter (2) on enclosure (5) with two new lockwashers (4) and screws (3). Install circuit leads 22A, 21A, 3AA, 18C, and 27A (1) on ground fault interrupter (2).

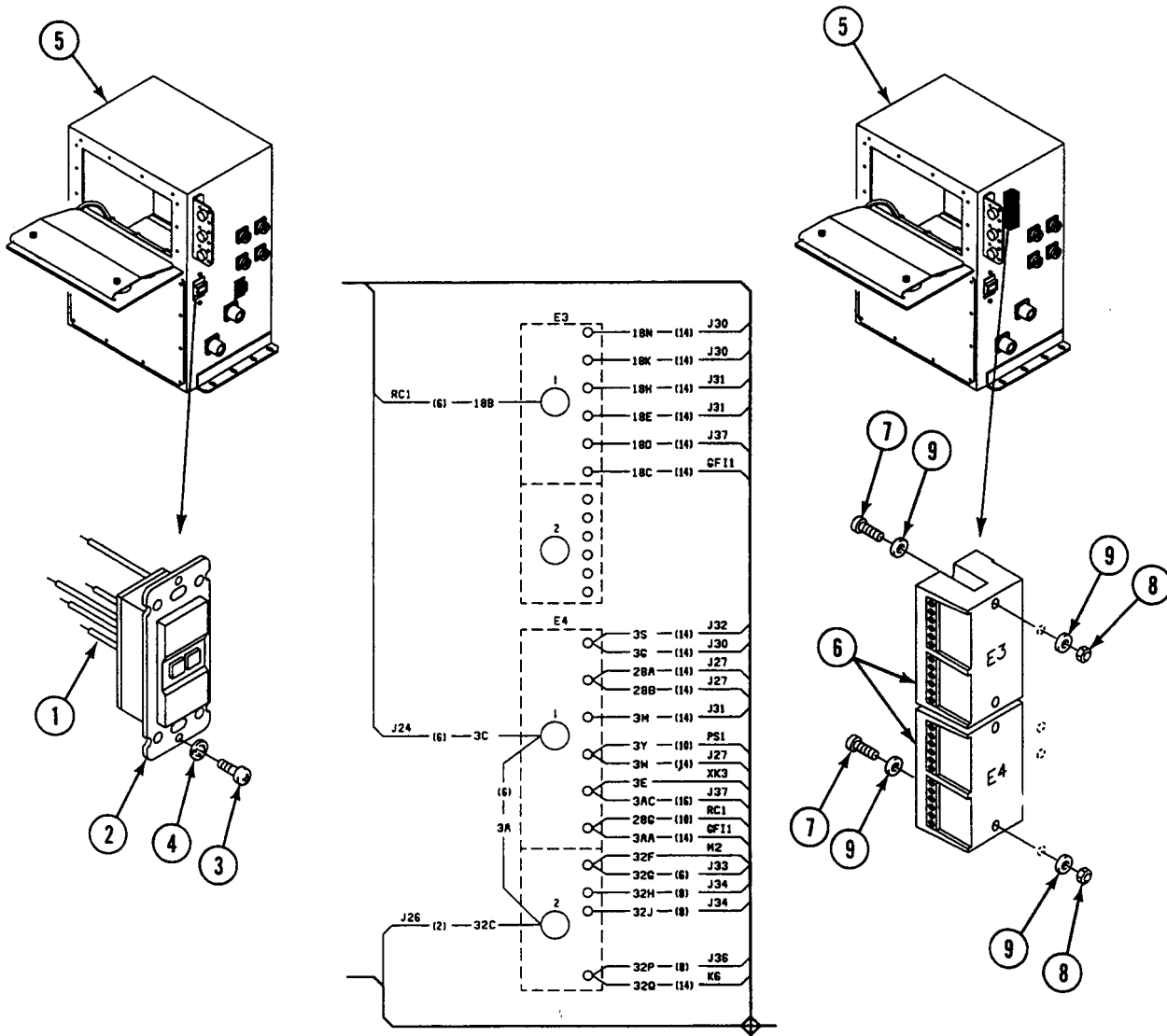

3. Install connector J29 (1), four screws (2), and new locknuts (3) on enclosure (4). Install circuit lead 34A (5) on J29 (1).
4. Install connector J28 (6), four screws (7), and new locknuts (8) on enclosure (4). Install circuit lead 44A (9) on J28 (6).
5. Install connector J27 (10), four screws (11), and new locknuts (12) on enclosure (4). Install circuit leads 11A, 28A, 12A, 28B, and 3W (13) on J27 (10).
6. Install connector J37 (14), four screws (15), and new locknuts (16) on enclosure (4). Install circuit leads 20B, 18D, and 3AC (17) on J37 (14).
7. Install connector J25 (18), connector J26 (19), two dust caps (20) with retainers, eight screws (21), and new locknuts (22) on enclosure (4).
8. Install circuit 32C lead (23), screw (24), and lockwasher (25) on negative terminal of connector J26 (19).
9. Install circuit 36C lead (26), screw (27), and lockwasher (28) on positive terminal of connector J26 (19).
10. Install circuit 32E lead (29), screw (30), and lockwasher (31) on negative terminal of connector J25 (18).
11. Install circuit 31A lead (32), screw (33), and lockwasher (34) on positive terminal of connector J25 (18).

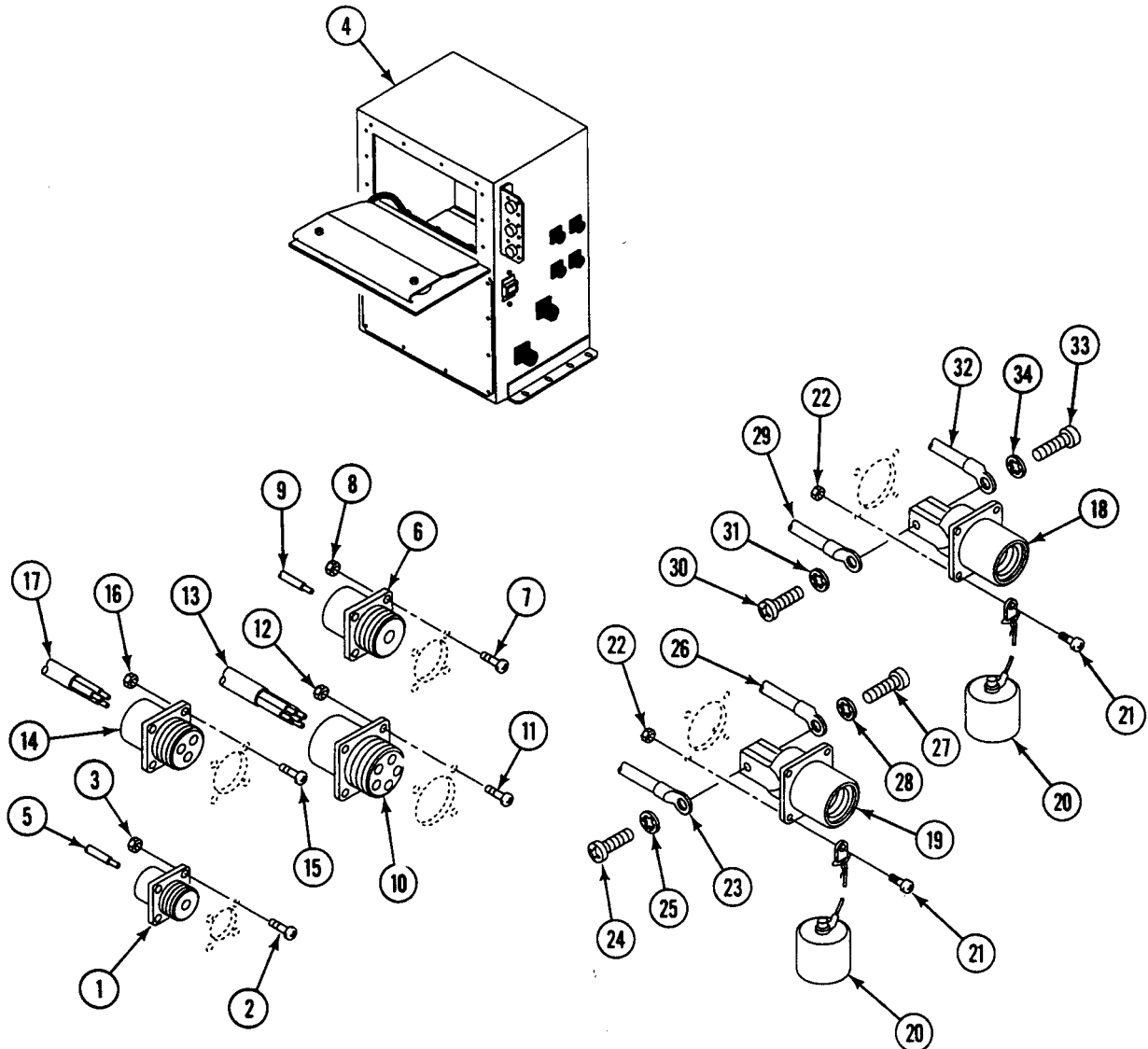

12. Close faceplate (11) and install 10 screws (9) and new lockwashers (10).
13. Move power supplies (7) into the proper position inside power enclosure (4). Have helper assist.
14. Install eight screws (5), new lockwashers (6) and secure power supplies (7) to bracket (8) inside enclosure (4).
15. Install cover (3), 12 new lockwashers (2), and screws (1) on power enclosure (4).

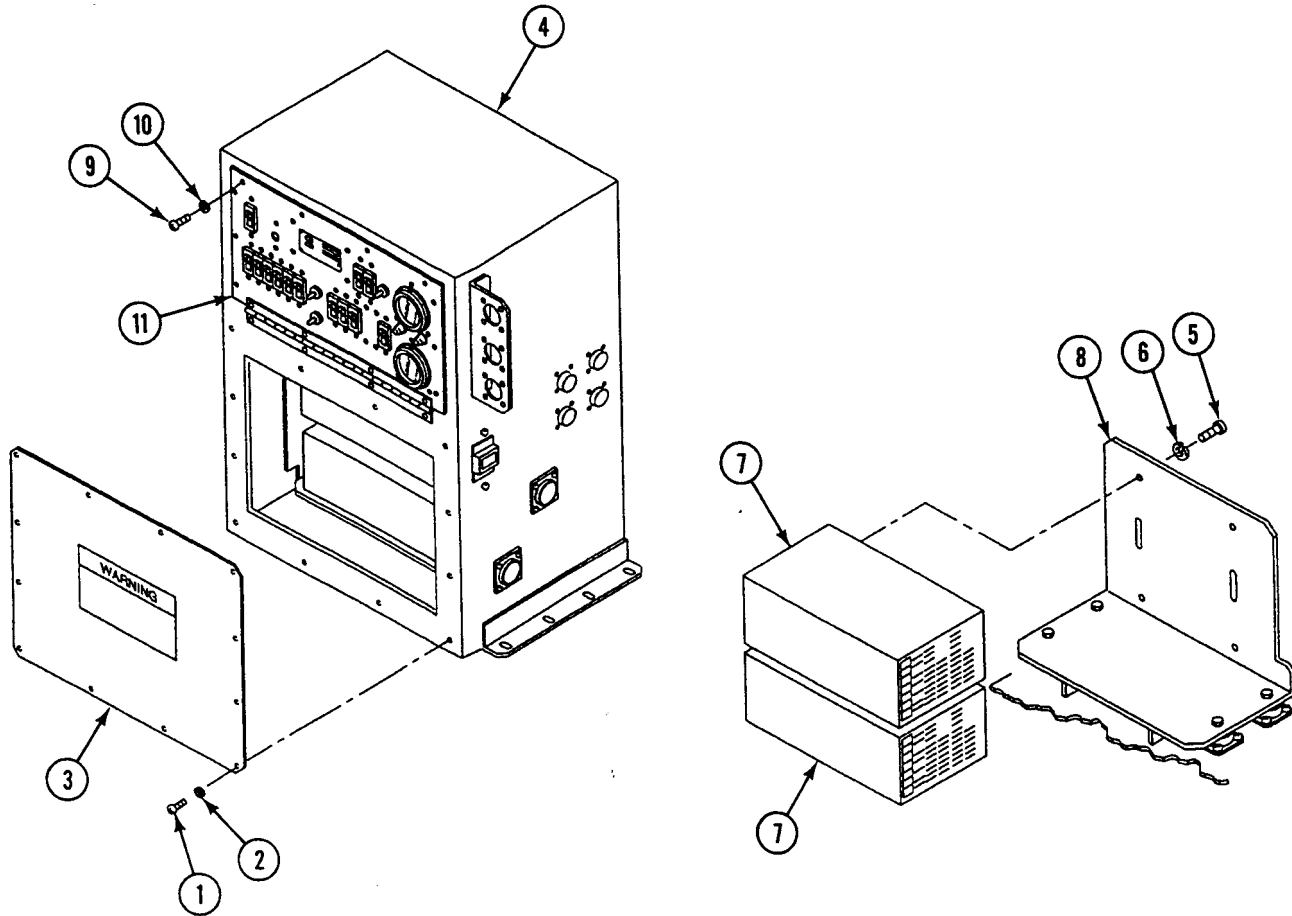

FOLLOW-THROUGH STEPS

1. Install power control enclosure assembly (see your -20).

END OF TASK

REPAIR POWER CONTROL ENCLOSURE, REAR PANEL (M1068A3 ONLY)

0093 00

THIS WORK PACKAGE COVERS:

Disassembly (page 0093 00-1).
 Assembly (page 0093 00-5).

INITIAL SETUP:

Maintenance Level

Direct Support

Personnel Required

Power-Generation Equipment Repairer 52D10

Tools and Special Tools

General Mechanic's Tool Kit (WP 0120 00, Item 62)

References

See your -10
 See your -20

Materials/Parts

Locknut (9)
 Lockwasher (10)
 Strap

Equipment Condition

Power control enclosure assembly removed (see your -20)

DISASSEMBLY

NOTE

Tag all wires before disconnecting them.

1. Remove ten screws (1), lockwashers (2), and lower faceplate (3). Discard lockwashers.
2. Remove nut (4), lockwasher (5), and lead 31A (6) from terminal A1 of relay K6 (7).
3. Remove nut (4), lockwasher (5), and leads 31B and 31C (8) from terminal A2 of relay K6 (7).

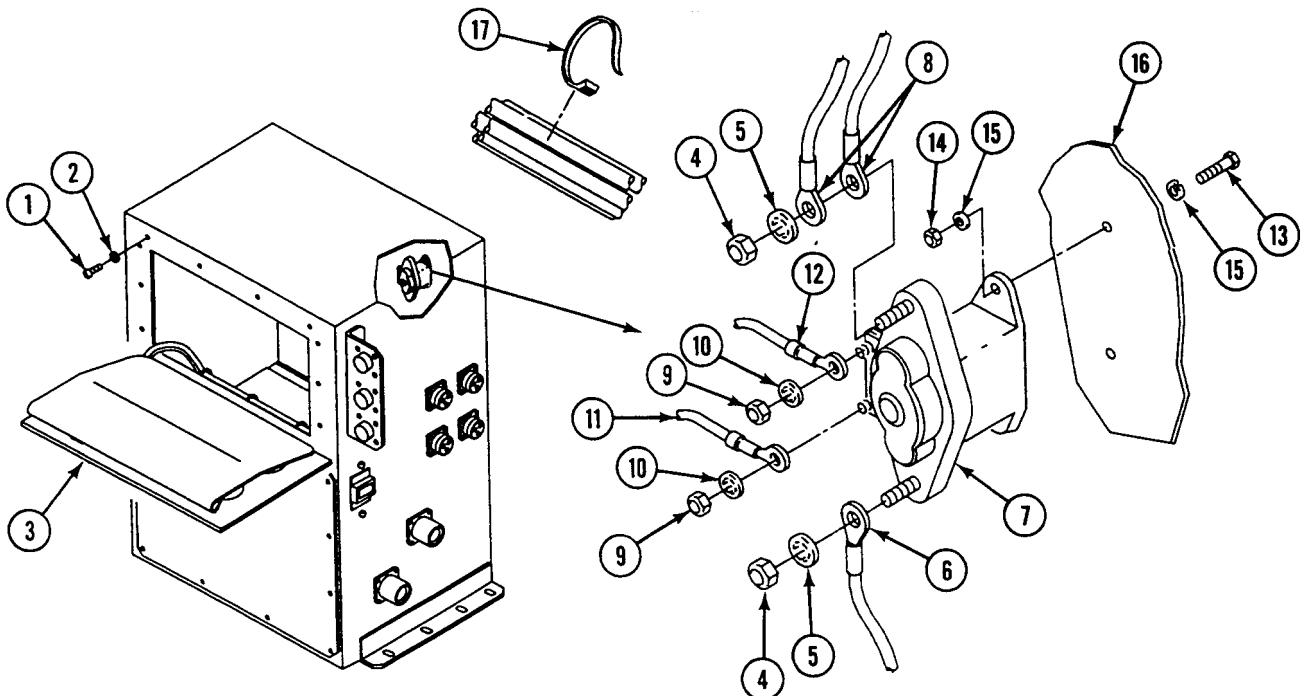

4. Remove nut (9), lockwasher (10), and lead 44A (11) from terminal X1 of relay K6 (7).
5. Remove nut (9), lockwasher (10), and lead 32Q (12) from terminal X2 of relay K6 (7).
6. Remove two screws (13), locknuts (14), four washers (15), and relay K6 (7) from rear panel (16). Discard locknuts.
7. Remove straps (17) from leads as required. Discard straps.

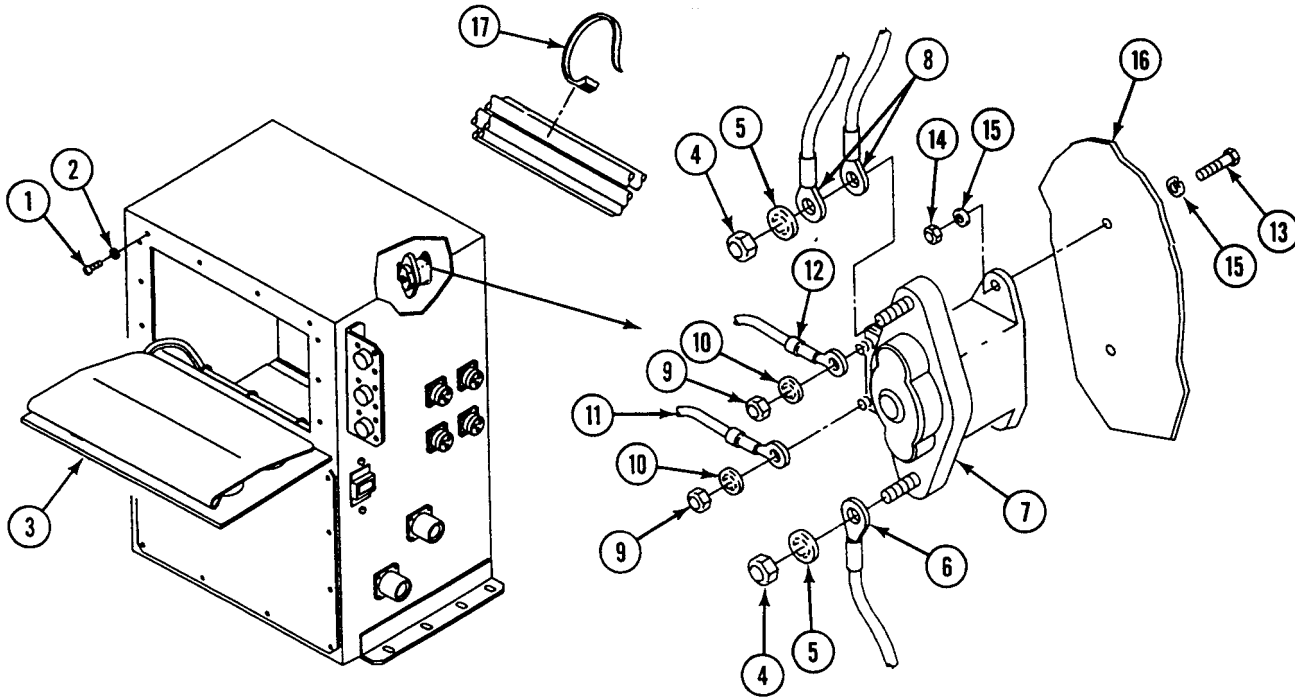

8. Remove leads 1C and 1D (1) from terminal T1 of contactor relay K1 (2).
9. Remove leads 2C, 2D and 2F (3) from terminal T2 of contactor relay K1 (2).
10. Remove leads 8A and 8B (4) from terminal L2 of contactor relay K1 (2).
11. Remove lead 2F (5) from terminal A2 of contactor relay K1 (2).
12. Remove lead 5A (6) from terminal A1 of contactor relay K1 (2).
13. Remove lead 7A (7) from terminal L1 of contactor relay K1 (2).
14. Remove four screws (8), locknuts (9), washers (10), and contactor relay K1 (2) from rear panel (11). Discard locknuts.
15. Disconnect leads 16A and 16B (12) from terminal A2 of reversing contactor RC1 (13).
16. Disconnect leads 28G and 28D (14) from terminal L2 of reversing contactor RC1 (13).
17. Disconnect lead 28D (14) from terminal A1 of reversing contactor RC1 (13).
18. Disconnect leads 13A and 13D (15) from terminal L1 of reversing contactor RC1 (13).
19. Disconnect lead 9B (16) from terminal 51 of reversing contactor RC1 (13).
20. Disconnect leads 15A and 15B (17) from terminal 52 of reversing contactor RC1 (13).
21. Disconnect leads 17A and 17B (18) from terminal T1 of reversing contactor RC1 (13).
22. Disconnect leads 18A and 18B (19) from terminal T2 of reversing contactor RC1 (13).

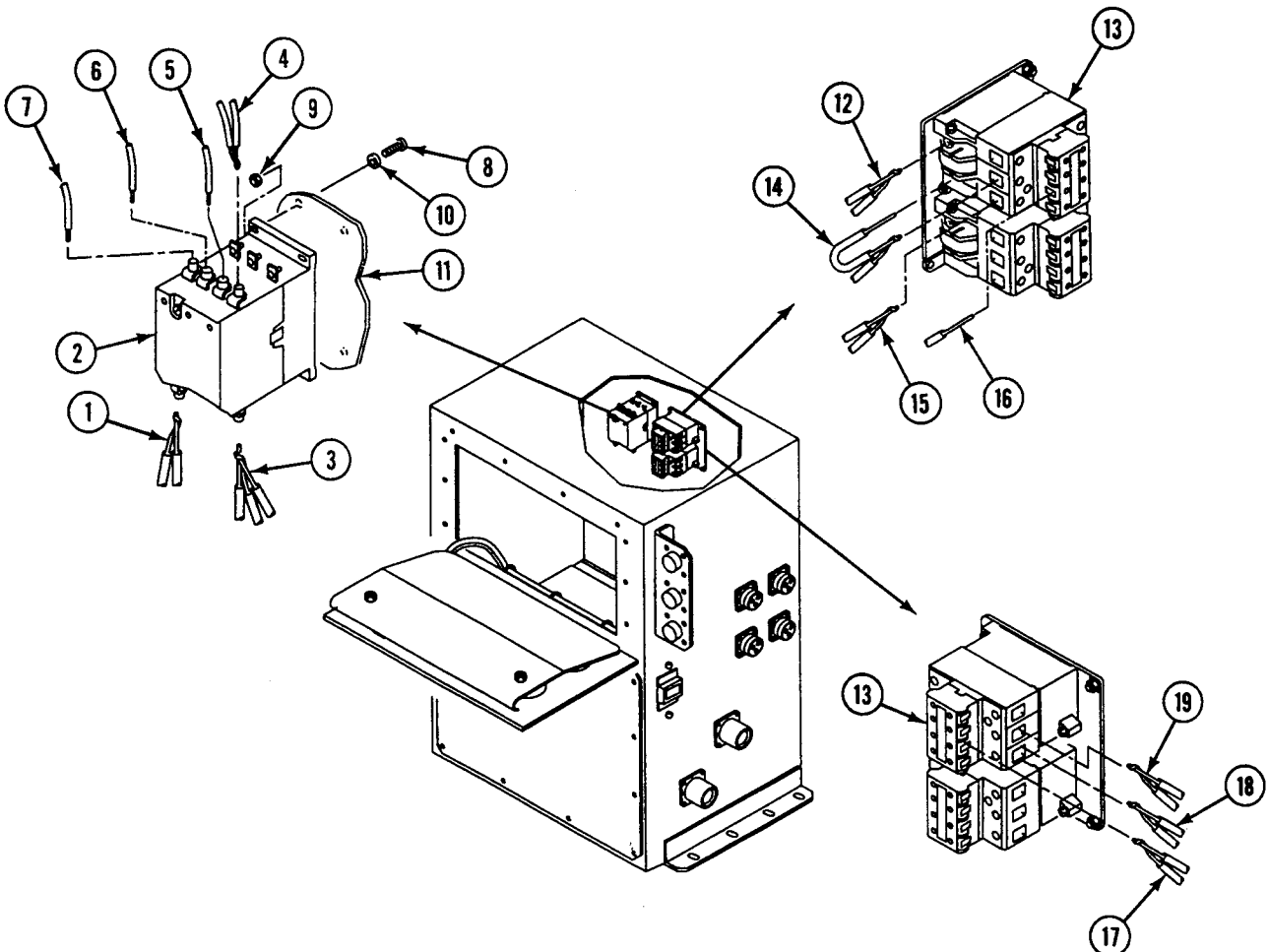

23. Disconnect lead 15A (1) from terminal A2 of contactor RC1 (2).
24. Disconnect leads 8A, 8D, and 8E (3) from terminal L2 of contactor RC1 (2).
25. Disconnect leads 8G and 8E (4) from terminal A1 of contactor RC1 (2).
26. Disconnect leads 9A, 9B, and 9C (5) from terminal L1 of contactor RC1 (2).
27. Disconnect lead 13D (6) from terminal 51 of contactor RC1 (2).
28. Disconnect lead 14A (7) from terminal 52 of contactor RC1 (2).
29. Disconnect lead 17A (8) from terminal T1 of contactor RC1 (2).
30. Disconnect lead 18A (9) from terminal T2 of contactor RC1 (2).
31. Remove three screws (10), locknuts (11), washers (12), and contactor RC1 (2) from rear panel (13). Discard locknuts.

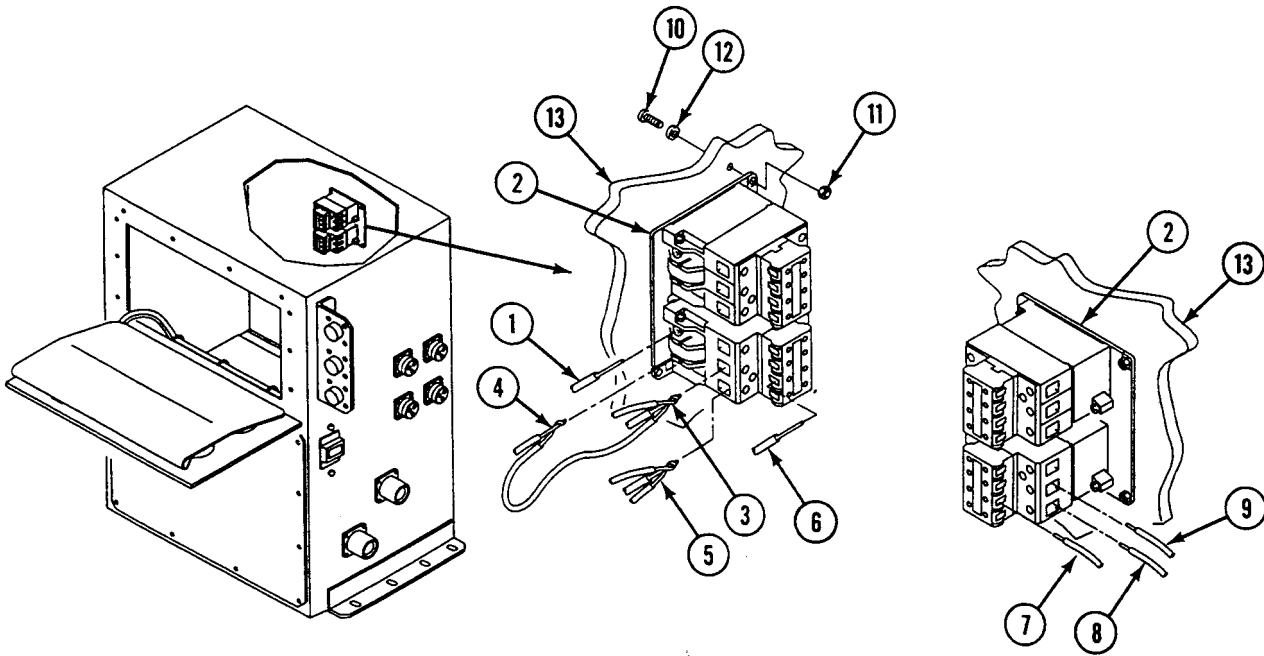

ASSEMBLY

1. Install contactor RC1 (2), three screws (10), washers (12), and new locknuts (11) in rear panel (13).
2. Install lead 18A (9) in terminal T2 of contactor RC1 (2).
3. Install lead 17A (8) in terminal T1 of contactor RC1 (2).
4. Install lead 14A (7) in terminal 52 of contactor RC1 (2).
5. Install lead 13D (6) in terminal 51 of contactor RC1 (2).
6. Install leads 9A, 9B and 9C (5) in terminal L1 of contactor RC1 (2).
7. Install leads 8G and 8E (4) in A1 of contactor RC1 (2).
8. Install leads 8A, 8D, and 8E (3) in terminal L2 of contactor RC1 (2).
9. Install lead 15A (1) in terminal A2 of contactor RC1 (2).

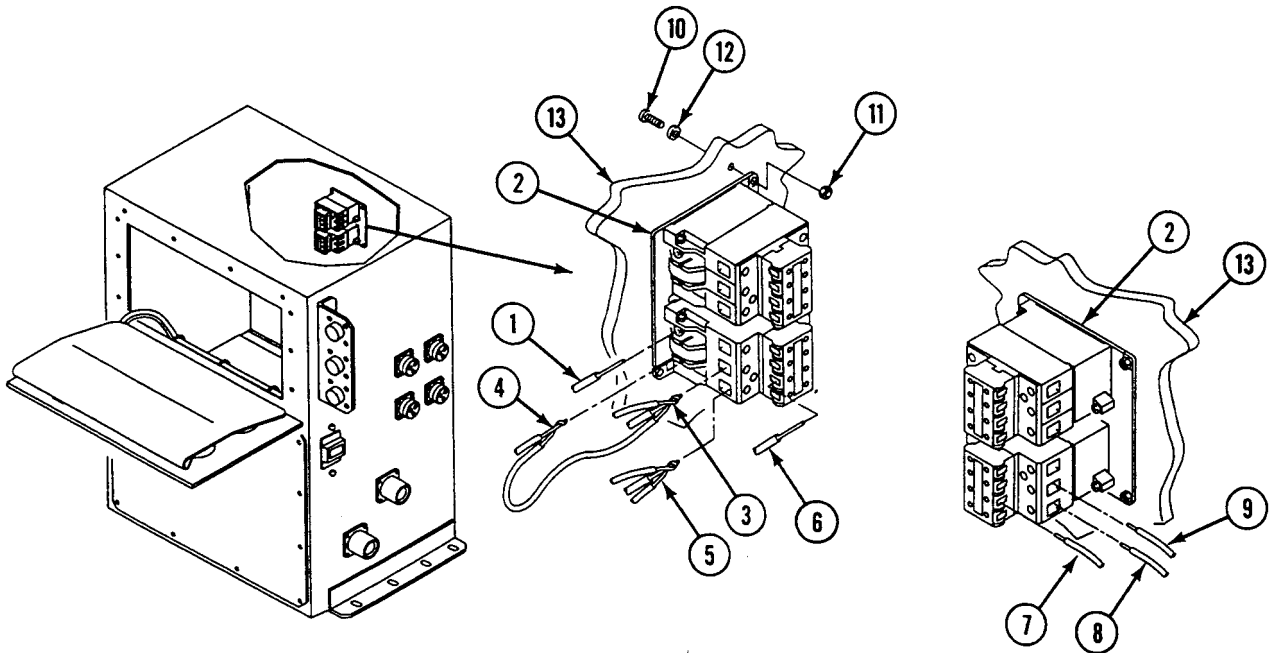

10. Install leads 18A and 18B (19) in terminal T2 of reversing contactor RC1 (13).
11. Install leads 17A and 17B (18) in terminal T1 of reversing contactor RC1 (13).
12. Install leads 15A and 15B (17) in terminal 52 of reversing contactor RC1 (13).
13. Install lead 9B (16) in terminal 51 of reversing contactor RC1 (13).
14. Install leads 13A and 13D (15) in terminal L1 of reversing contactor RC1 (13).
15. Install lead 28D (14) in terminal A1 of reversing contactor RC1 (13).
16. Install leads 28G and 28D (14) in terminal L2 of reversing contactor RC1 (13).
17. Install leads 16A and 16B (12) in terminal A2 of reversing contactor RC1 (13).

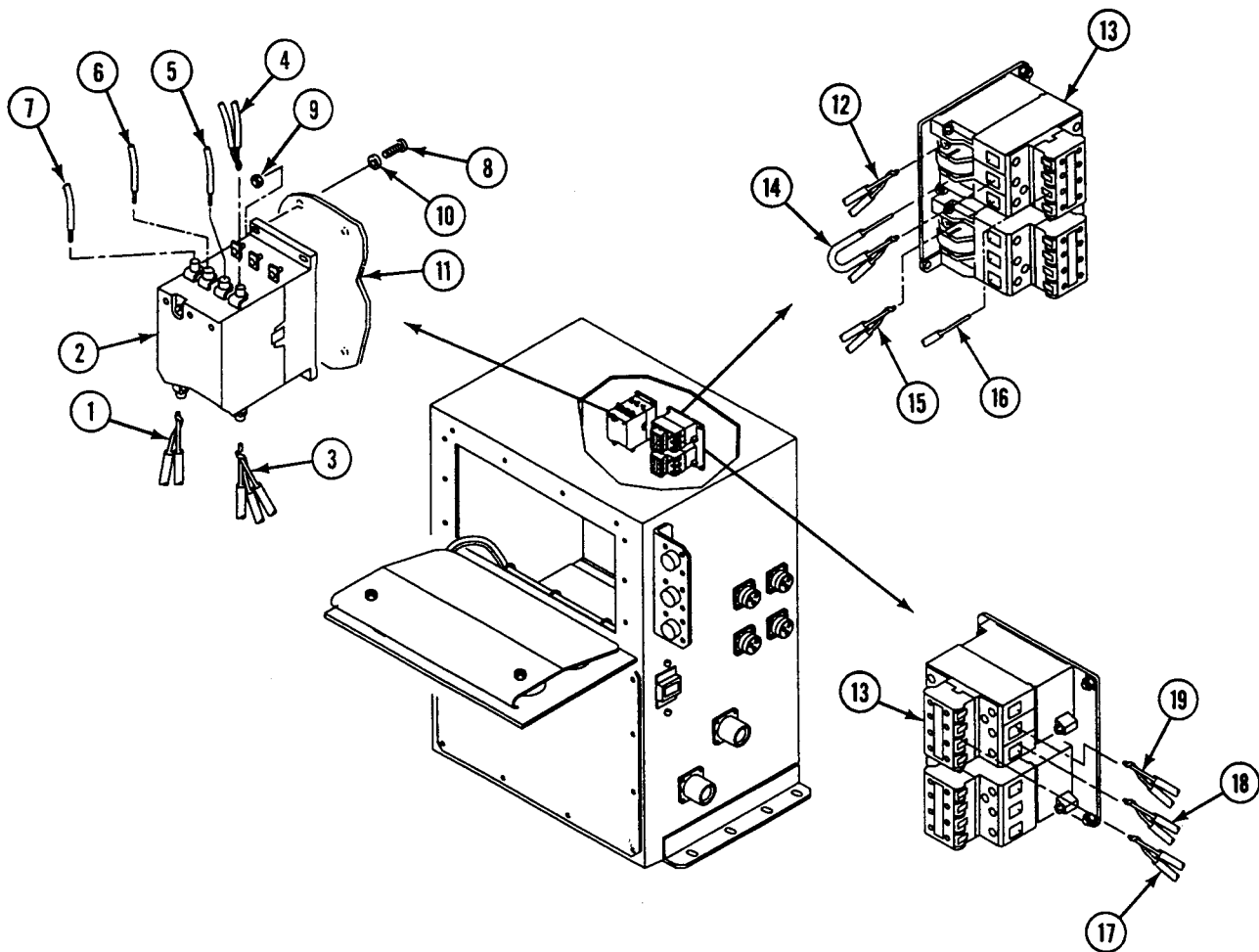

18. Install contactor relay K1 (2), four screws (8), washers (10), and new locknuts (9) on rear panel (11).
19. Install lead 7A (7) in terminal L1 of contactor relay K1 (2).
20. Install lead 5A (6) in terminal A1 of contactor relay K1 (2).
21. Install lead 2F (5) in terminal A2 of contactor relay K1 (2).
22. Install leads 8A and 8B (4) in terminal L2 of contactor relay K1 (2).
23. Install leads 2C, 2D, and 2F (3) in terminal T2 of contactor relay K1 (2).
24. Install leads 1C and 1D (1) in terminal T1 of contactor relay K1 (2).

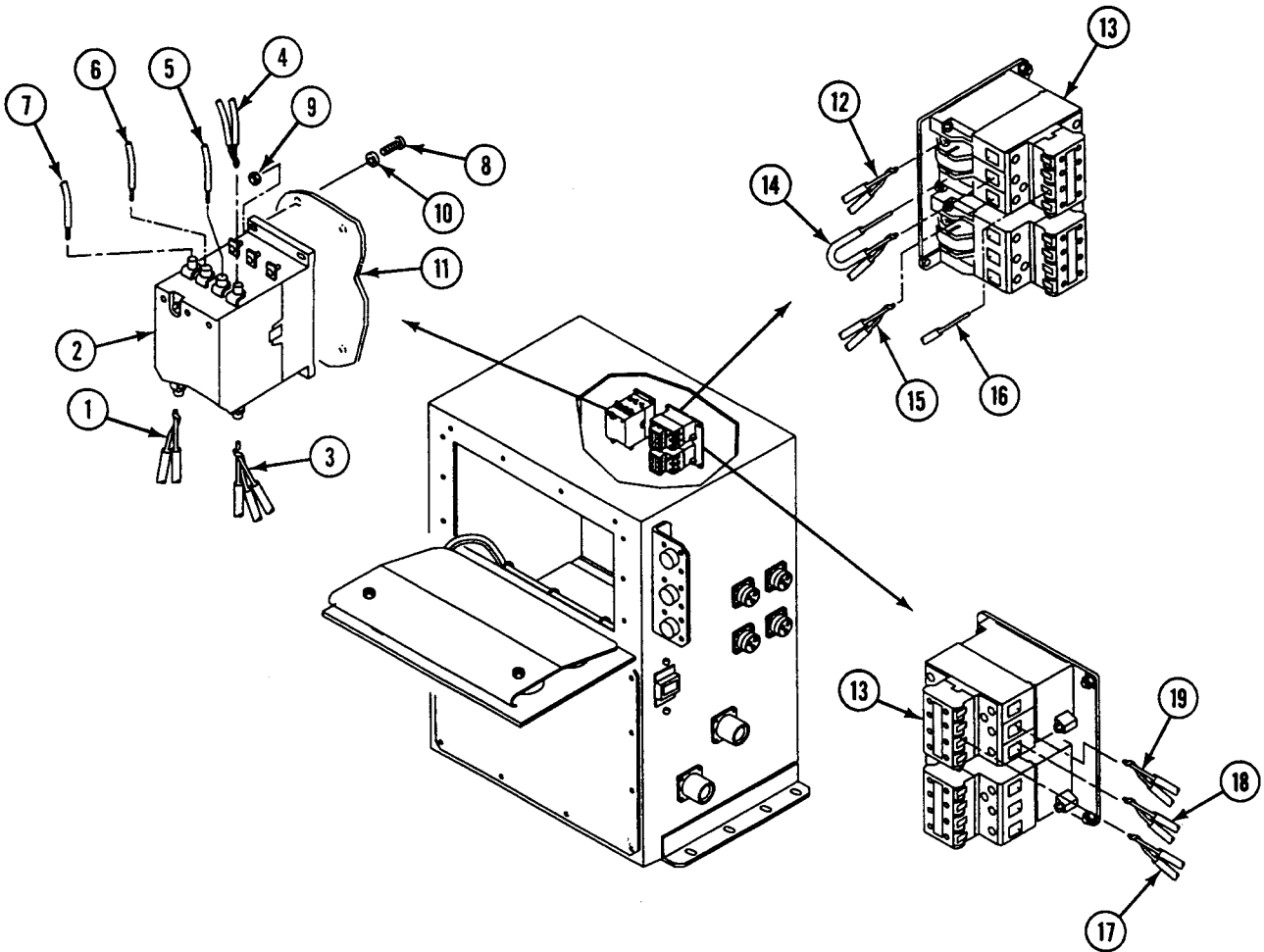

25. Secure leads with new straps (17) as required.
26. Install relay K6 (7), two screws (13), new locknuts (4), and four washers (15) on rear panel (16).
27. Install lead 32Q (12), lockwasher (5), and nut (4) on terminal X2 of relay K6 (7).
28. Install lead 44A (11), lockwasher (5), and nut (4) on terminal X1 of relay K6 (7).
29. Install leads 31B and 31C (8), lockwashers (5), and nut (4) on terminal A2 of relay K6 (7).
30. Install lead 31A (6), lockwasher (5), and nut (4) on terminal A1 of relay K6 (7).
31. Close faceplate (3) and install ten screws (1) and new lockwashers (2).

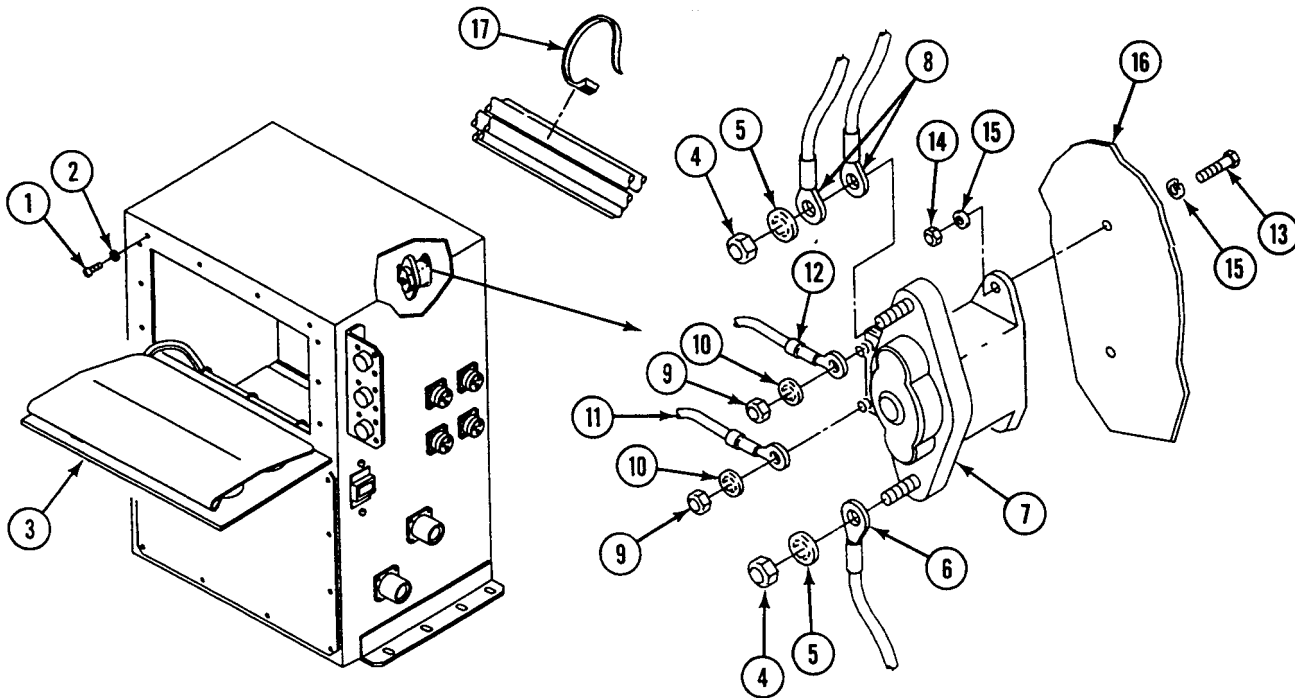

FOLLOW THROUGH STEPS

1. Install power control enclosure assembly (See your -20).

END OF TASK

**REPLACE/REPAIR INVERTER AND INVERTER HOUSING ASSEMBLY A2
(M1068A3 ONLY)**

0094 00

THIS WORK PACKAGE COVERS:

Removal (page 0094 00-1).
Installation (page 0094 00-6).

INITIAL SETUP:

Maintenance Level

Direct Support

Personnel Required

Power-Generation Equipment Repairer 52D10
Helper (H)

Tools and Special Tools

General Mechanic's Tool Kit (WP 0120 00, Item 62)

References

See your -10
See your -20
TM 11-7010-256-12&P

Materials/Parts

Lockwasher (12)
Lockwasher (6)
Lockwasher (4)
Self-locking nut (16)
Self-locking nut (8)
Self-locking nut (8)
Self-locking nut (4)
Self-locking nut (3)
Self-locking nut (2)

Equipment Condition

Engine stopped (See your -10)
Carrier blocked (See your -10)
All external power disconnected
(TM 11-7010-256-12&P)
Battery ground lead disconnected (See your -20)
Power control enclosure removed (See your -20)

REMOVAL

NOTE

It is not necessary to remove the housing to remove one or both inverters.

1. Remove ten screws (1), lockwashers (2), and cover (3) from inverter housing (4). Discard lockwashers.
2. Remove four screws (5), locknuts (6), and terminal block TB2 (7) from cover (3). Discard locknuts.

REPLACE/REPAIR INVERTER AND INVERTER HOUSING ASSEMBLY A2 (M1068A3 ONLY) — Continued

0094 00

3. Remove two screws (8), locknuts (9), and terminal block TB1 (10) from cover (3). Discard locknuts.

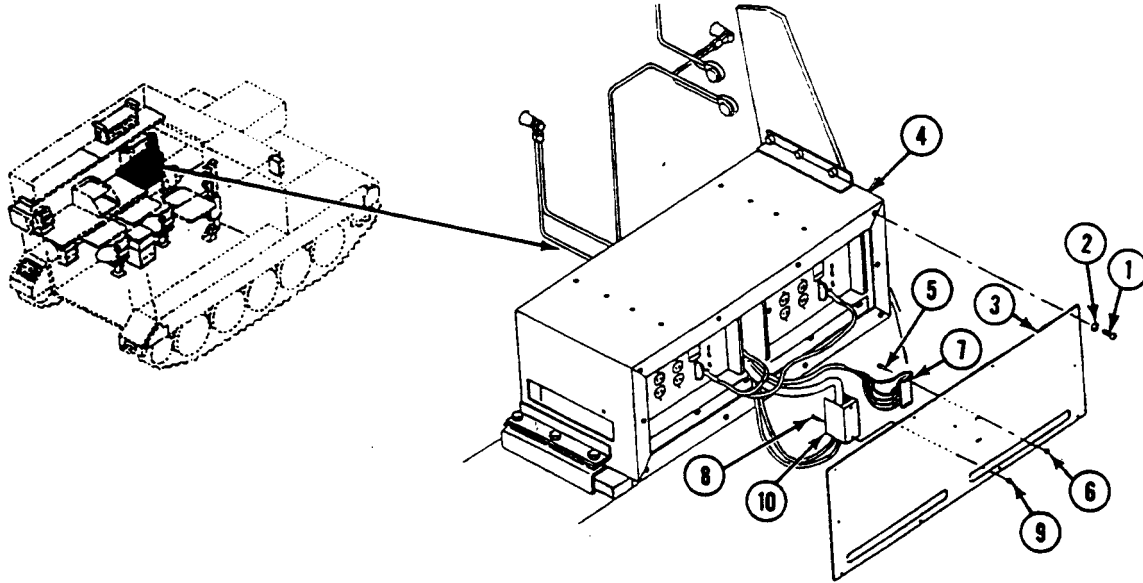

NOTE

Tag leads/cables before removing/disconnecting.

4. Remove ten screws (1), cable W5 (2), and six leads (3) from terminal block TB2 (4).
5. Remove two set screws (5), cable W6 (6), and two leads E4 (7) from terminal block TB1 (8).
6. Remove screw (9), ground lead W632 (10), ground lead W432 (11), and lockwasher (12) from carrier wall. Discard lockwasher.
7. Remove screw (9), two ground leads E5 (13), and lockwasher (12) from carrier wall. Discard lockwasher.
8. Remove three screws (14), locknuts (15), six washers (16), from blackout curtain (17) and inverter housing (18). Discard locknuts.
9. Disconnect two cable W15 connectors (19) from inverter IN1 (20) and inverter IN2 (21).

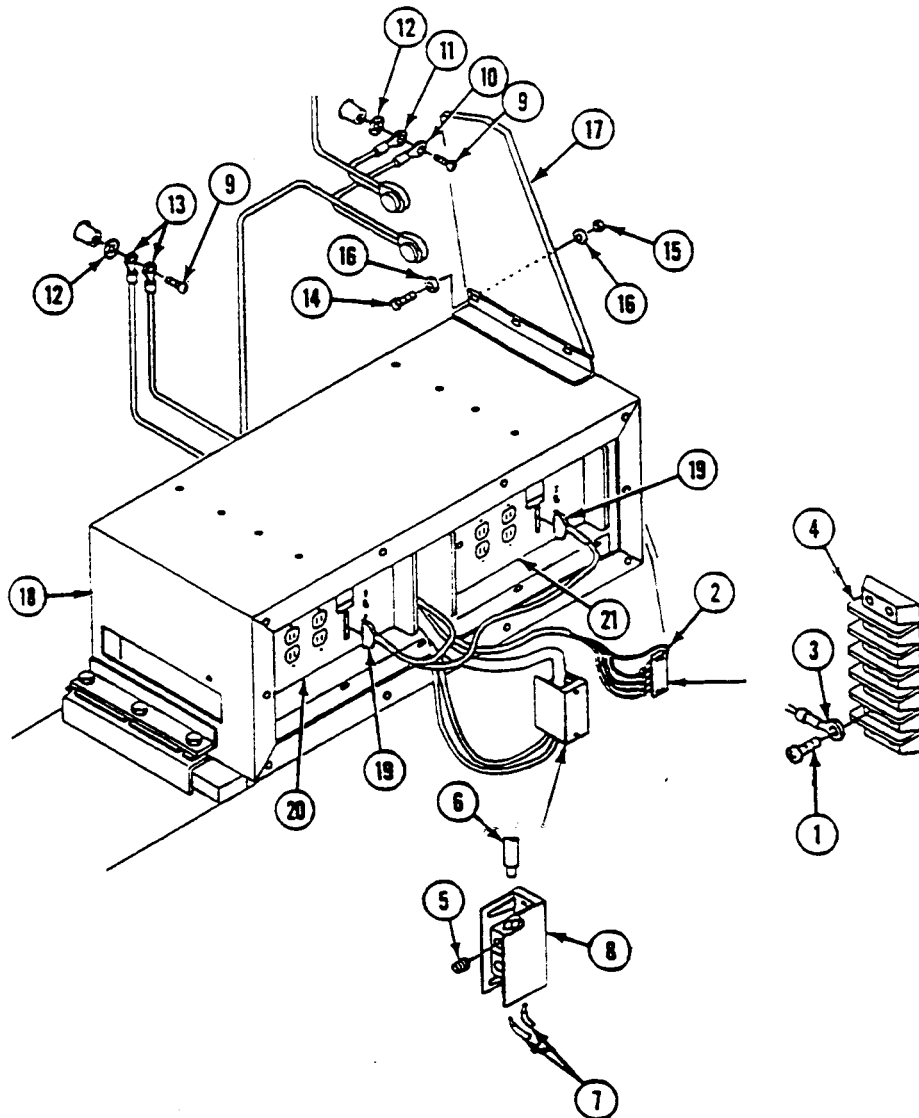

NOTE

Both inverters are removed the same way.

10. Remove three screws (1) and lockwashers (2) from mount (3) and tray (4). Discard lockwashers.
11. Remove mount (3) and inverter (5), from housing (6). Have Helper assist.
12. Remove four screws (7), washers (8), locknuts (9), and mount (3) from inverter (5). Discard locknuts.

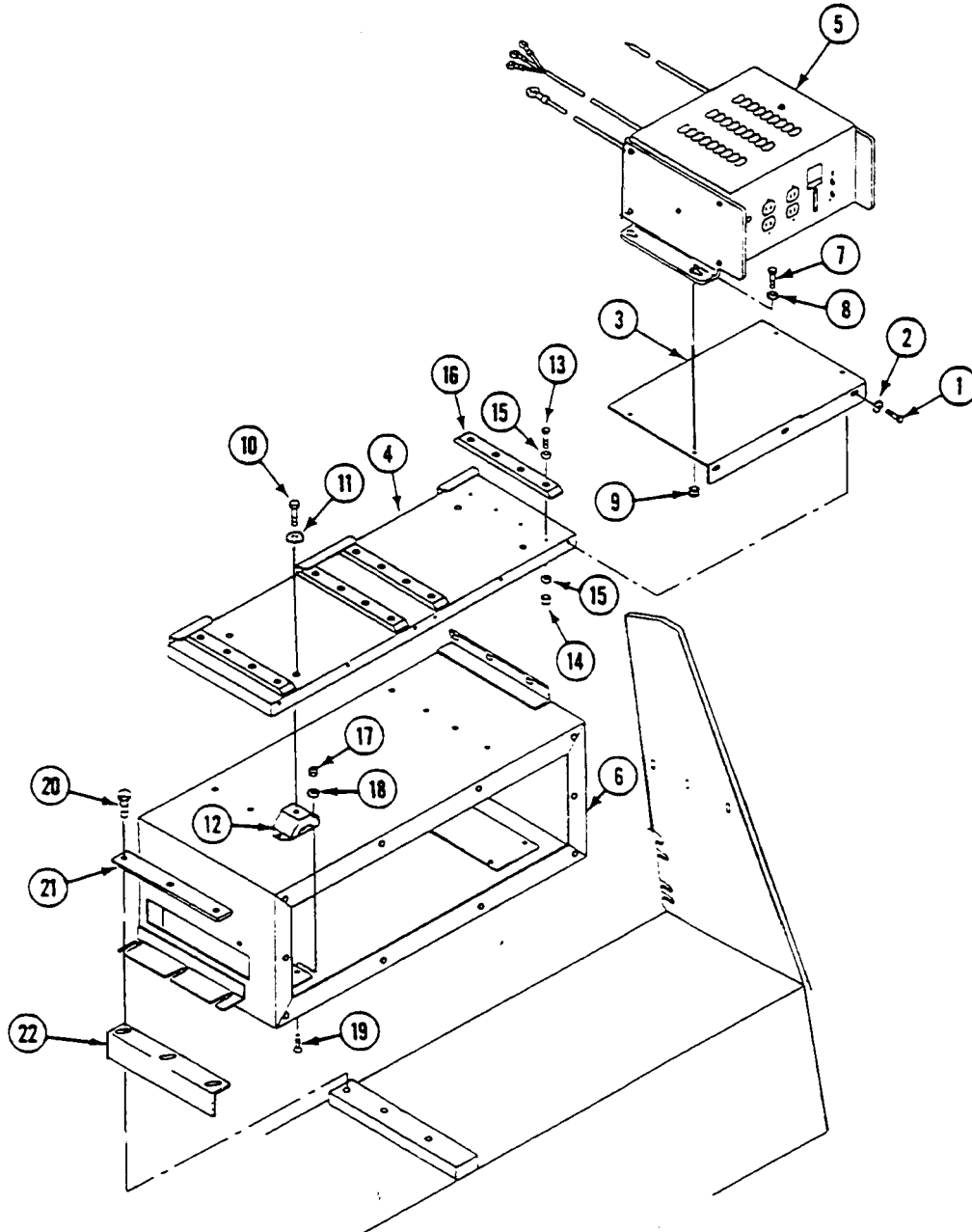

REPLACE/REPAIR INVERTER AND INVERTER HOUSING ASSEMBLY A2 (M1068A3 ONLY) — Continued

0094 00

13. Remove four screws (10), lockwashers (11), and tray (4) from four resilient mounts (12). Discard lockwashers.
14. Remove sixteen screws (13), locknuts (14), thirty-two washers (15), and four straps (16) from tray (4). Discard locknuts.
15. Remove eight locknuts (17), washers (18), screws (19), and four resilient mounts (12), from housing (6). Discard locknuts.
16. Remove three screws (20), mounting strip (21), inverter housing (6), and retaining strip (22) from sponson.

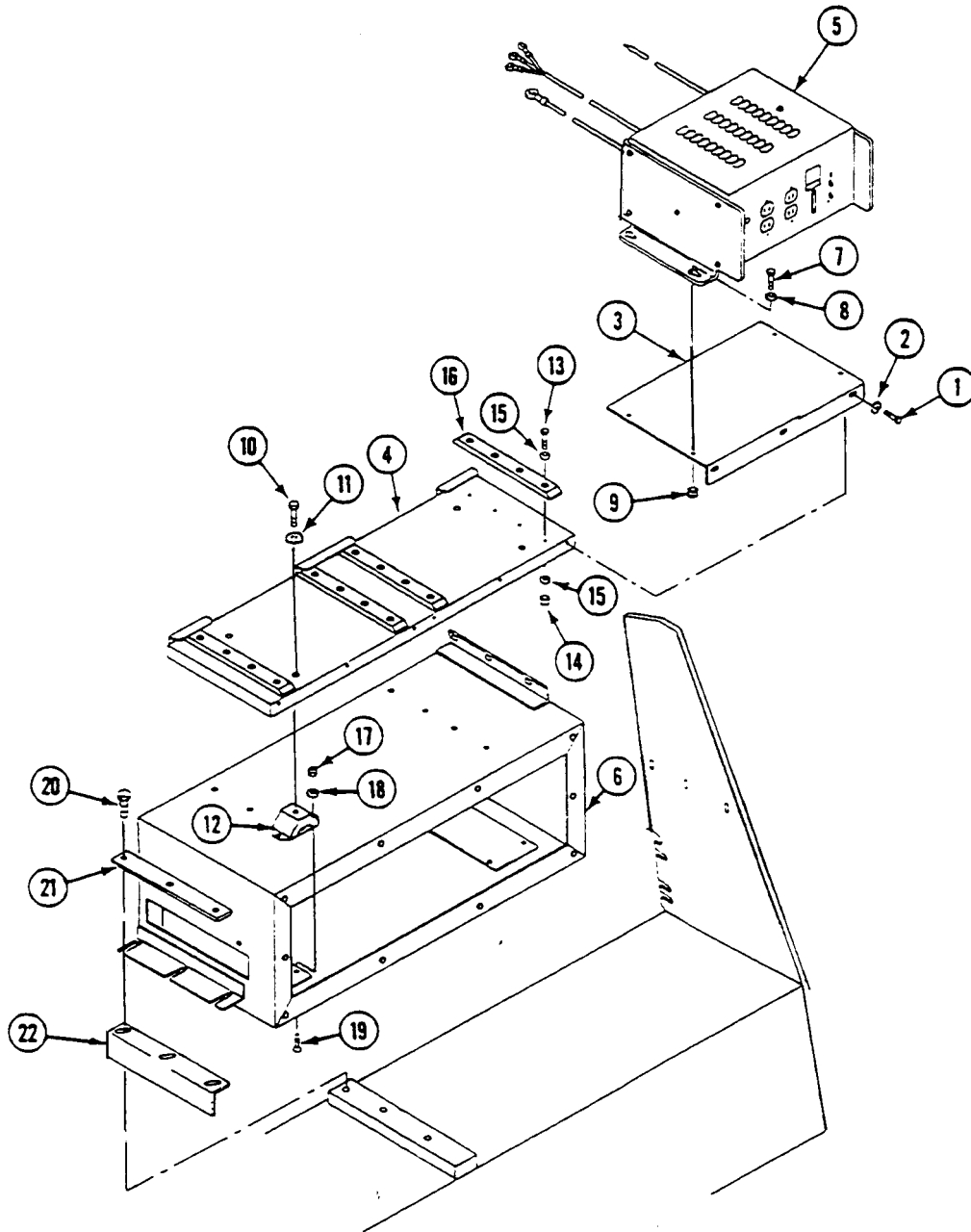

INSTALLATION

NOTE

Both inverters are installed the same way.

1. Install retaining strip (22), inverter housing (6), mounting strip (21), on sponson and secure with three screws (20).
2. Install four resilient mounts (12) on inverter housing (6) and secure with eight screws (19), washers (18), and new locknuts (17).

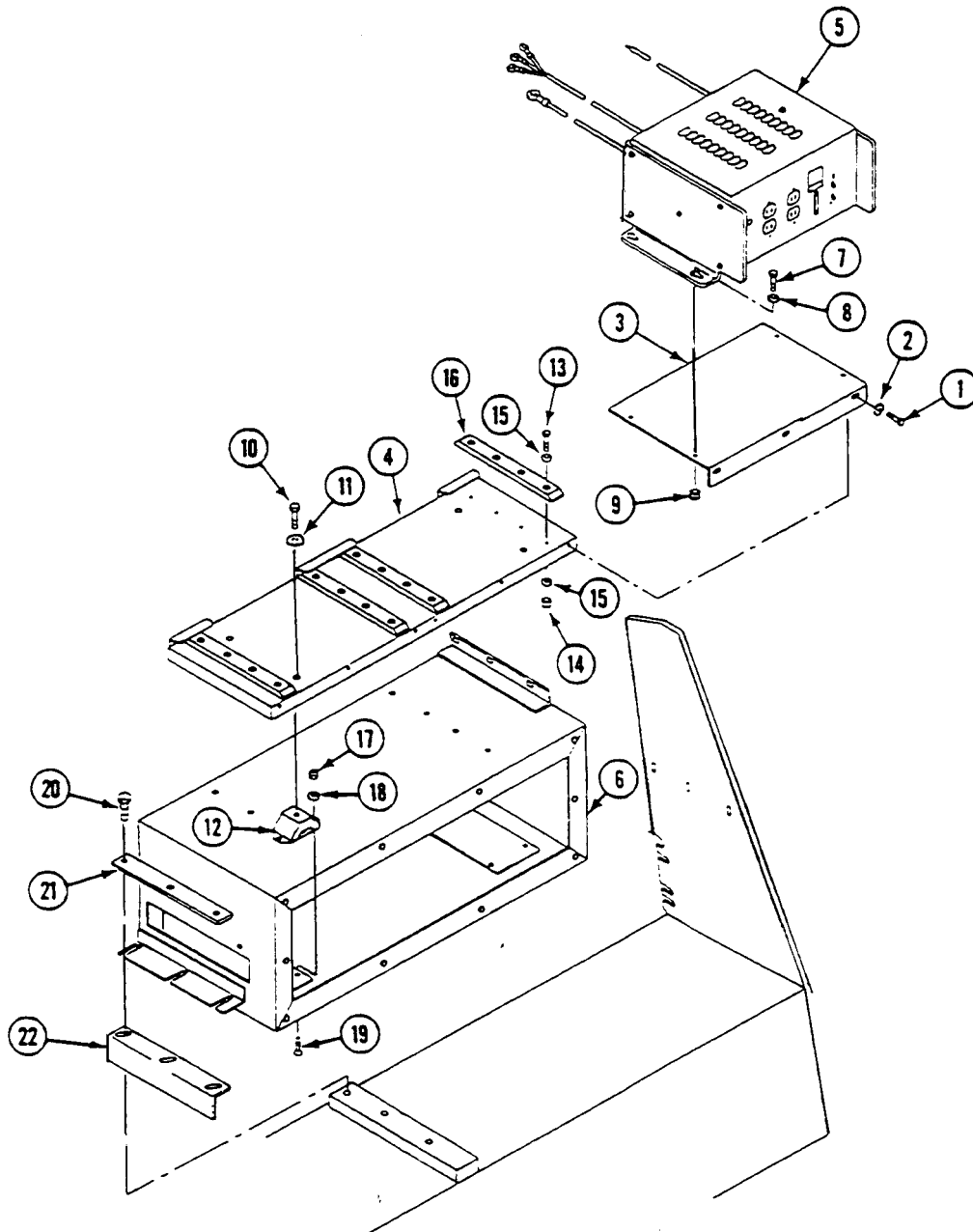

REPLACE/REPAIR INVERTER AND INVERTER HOUSING ASSEMBLY A2 (M1068A3 ONLY) — Continued

0094 00

3. Install four straps (16) on tray (4), secure with sixteen screws (13), thirty-two washers (15), and new locknuts (14).
4. Install tray (4) on four resilient mounts (12) and secure with four screws (10) and new lockwashers (11).
5. Install mount (3) on inverter (5) and secure with four screws (7), washers (8), and new locknuts (9).
6. Install mount (3) and inverter (5) in housing (6), secure on tray (4) with three screws (1) and new lockwashers (2). Have Helper assist.

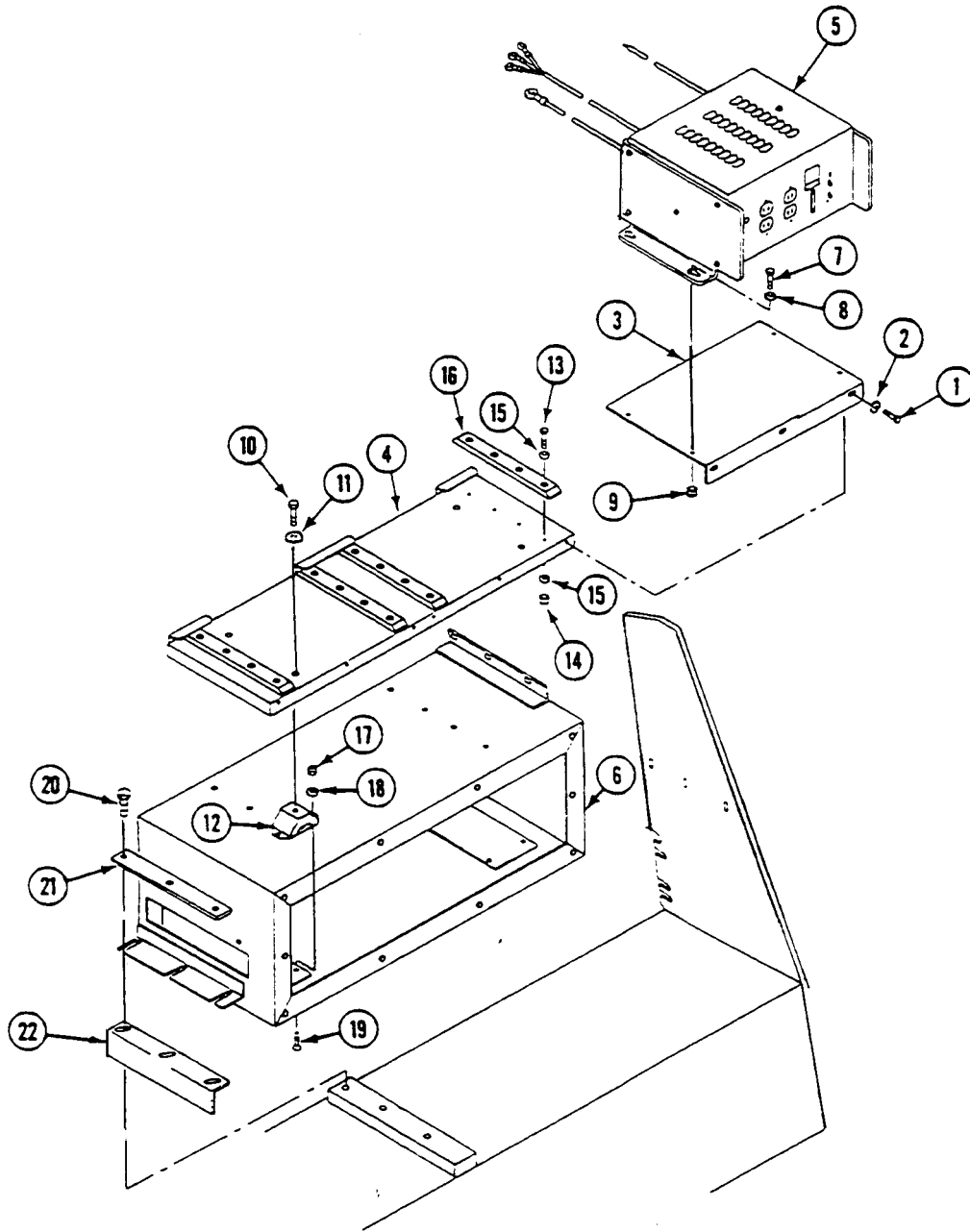



NOTE

Before installation of inverters IN1 and IN2, shut POWER switches OFF. The cascade remote harness W15 will control inverters.

Installation for inverters IN1 and IN2 are different, follow schematic for proper wiring connections:

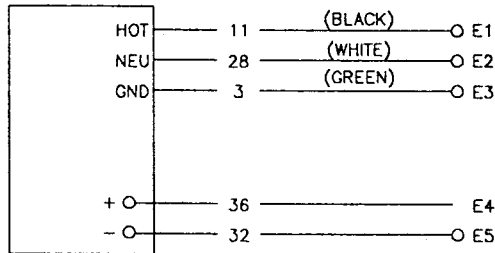
WIRING DIAGRAM



PART NUMBER	"A" 	"B" 
12383902-1 (IN1)	IN1 E1(A2TB2-1)	IN1 E2(A2TB2-2)
12383902-2 (IN2)	IN2 E1(A2TB2-3)	IN2 E2(A2TB2-4)

REPLACE/REPAIR INVERTER AND INVERTER HOUSING ASSEMBLY A2 (M1068A3 ONLY) — Continued

0094 00

7. Connect two cable W15 connectors (1) to inverter IN1 (2) and inverter IN2 (3).
8. Install blackout curtain (4) on inverter housing (5) and secure with six washers (6), three screws (7), and new locknuts (8).
9. Install two ground leads E5 (9) on carrier wall and secure with new lockwasher (10), and screw (11).
10. Install ground lead W432 (12) and ground lead W632 (13) on carrier wall and secure with new lockwasher (10) and screw (11).
11. Connect cable W6 (14) and two leads E4 (15) on terminal block TB1 (16) and secure with two set screws (17).
12. Connect cable W5 (18) and six leads (19) on terminal block TB2 (20) and secure with ten screws (21).

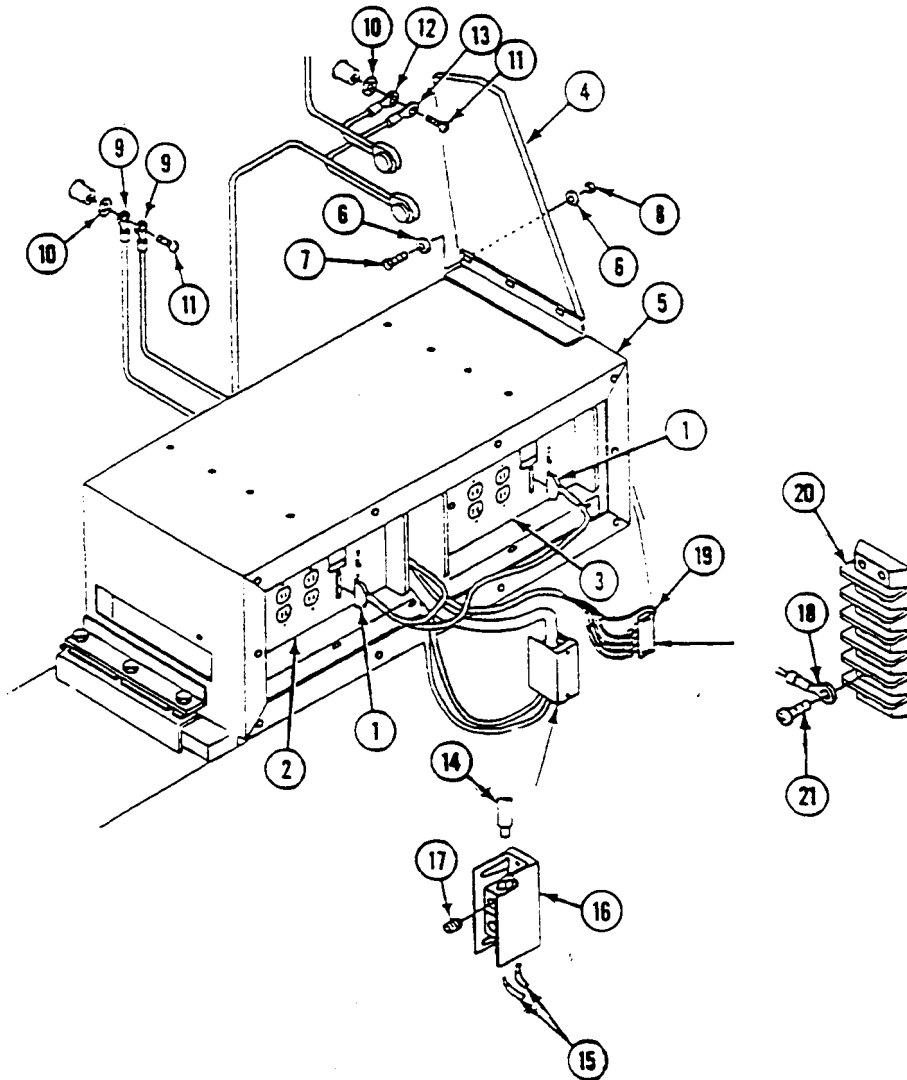

REPLACE/REPAIR INVERTER AND INVERTER HOUSING ASSEMBLY A2 (M1068A3 ONLY) — Continued

0094 00

13. Install terminal block TB1 (1) on cover (2) and secure with two screws (3) and new locknuts (4).
14. Install terminal block TB2 (5) on cover (2) and secure with four screws (6) and new locknuts (7).
15. Install cover (2) on inverter housing (8) and secure with ten screws (9) and new lockwashers (10).

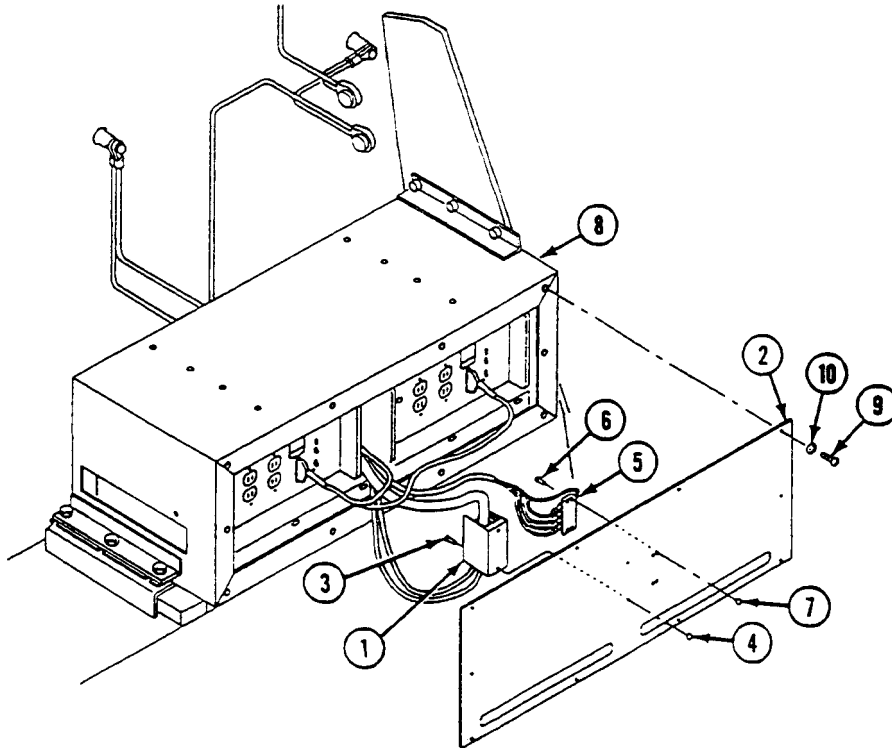
**FOLLOW-THROUGH STEPS**

1. Install power control enclosure (See your -20).
2. Connect battery ground lead (See your -20).

END OF TASK

REPAIR POWER ENTRY BOX ASSEMBLY A4 (M1068A3 ONLY)

0095 00

THIS WORK PACKAGE COVERS:

Disassembly (page 0095 00-1).
 Assembly (page 0095 00-3).

INITIAL SETUP:

Maintenance Level

Direct Support

Personnel Required

Power-Generation Equipment Repairer 52D10

Tools and Special Tools

General Mechanic's Tool Kit (WP 0120 00, Item 62)

References

See your -20

Materials/Parts

Locknut (8)
 Lock washer

Equipment Condition

Power entry box removed (see your -20)

DISASSEMBLY

1. Open lid (1) to access faceplate (2).
2. Remove six screws (3), washers (4), and faceplate (2) from power entry box (5).
3. Remove four screws (6), cap and chain (7), locknuts (8), and cable W14 (9) from AC POWER OUT hole on faceplate (2). Discard locknuts.
4. Remove four screws (10), cap and chain (11), locknuts (12), and cable W13 (13) from EXTERNAL POWER IN hole on faceplate (2). Discard locknuts.

NOTE

Tag all leads before removing from terminals.

5. Remove wingnut (14), two washers (15), nut (16), lock washer (17), screw (18), and five leads (19) from faceplate (2). Discard lock washer.

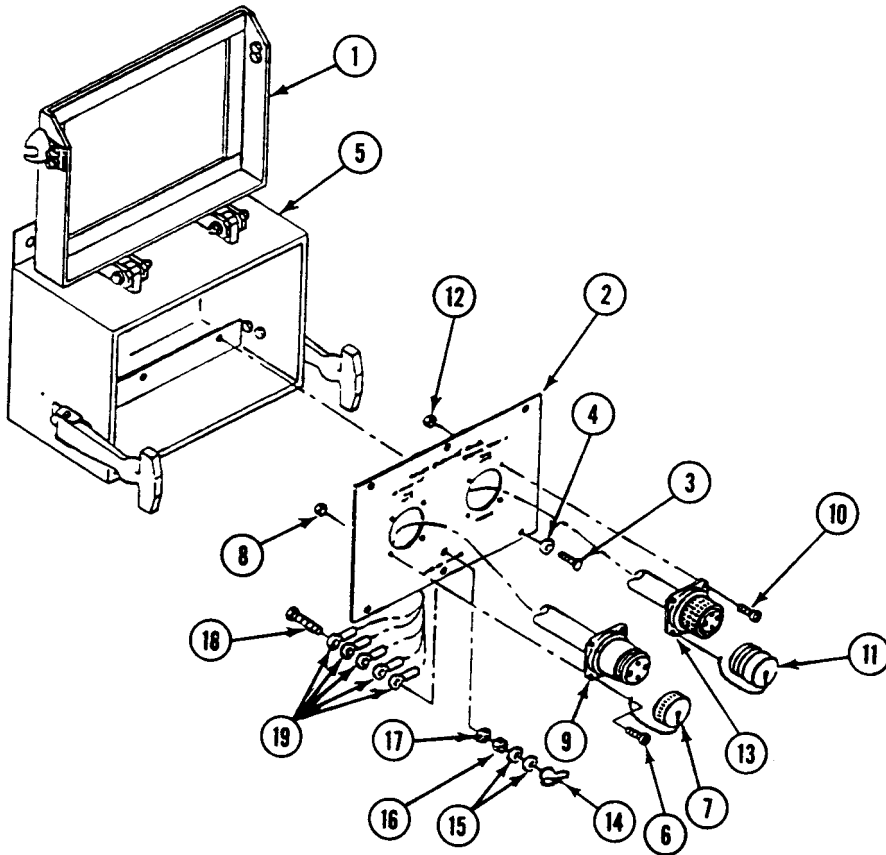

ASSEMBLY

1. Install five leads (19), screw (18), new lock washer (17), nut (16), two washers (15), and secure with wingnut (14) on faceplate (2).
2. Install cable W13 (13) in EXTERNAL POWER IN hole on faceplate (2) with cap and chain (11) and secure with four screws (10) and new locknuts (12).
3. Install cable W14 (9) in AC POWER OUT hole on faceplate (2) with cap and chain (7) and secure with four screws (6) and new locknuts (8).
4. Install faceplate (2) on power entry box (5) and secure with six screws (3) and washers (4).
5. Close and secure lid (1) on power entry box (5).

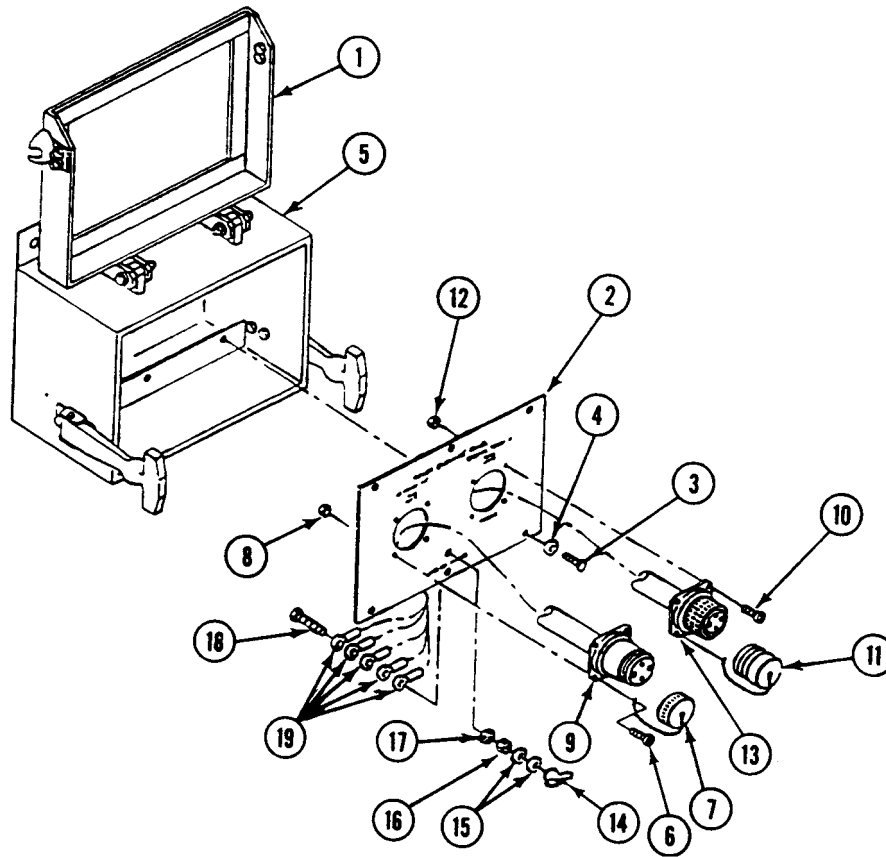

FOLLOW-THROUGH STEPS

1. Install power entry box (see your -20).

END OF TASK

REPAIR TENT INTERFACE PANEL BOX ASSEMBLY A5 (M1068A3 ONLY)

0096 00

THIS WORK PACKAGE COVERS:

Disassembly (page 0096 00-1).
 Assembly (page 0096 00-5).

INITIAL SETUP:

Maintenance Level

Direct Support

Personnel Required

Power-Generation Equipment Repairer 52D10
 Radio Repairer 29E10

Tools and Special Tools

General Mechanic's Tool Box (WP 0120 00, Item 62)
 Electronic Equipment Tool Kit (WP 0120 00, Item 61)

References

See your -10
 See your -20

Materials/Parts

Adhesive (WP 0122 00, Item 1)
 Lockwasher (14)
 Self-locking nut (30)

Equipment Condition

Tent interface panel box assembly
 removed (see your -20)

DISASSEMBLY

1. Remove 14 screws (1), lockwashers (2), and faceplate (3) from box (4). Discard lockwashers.

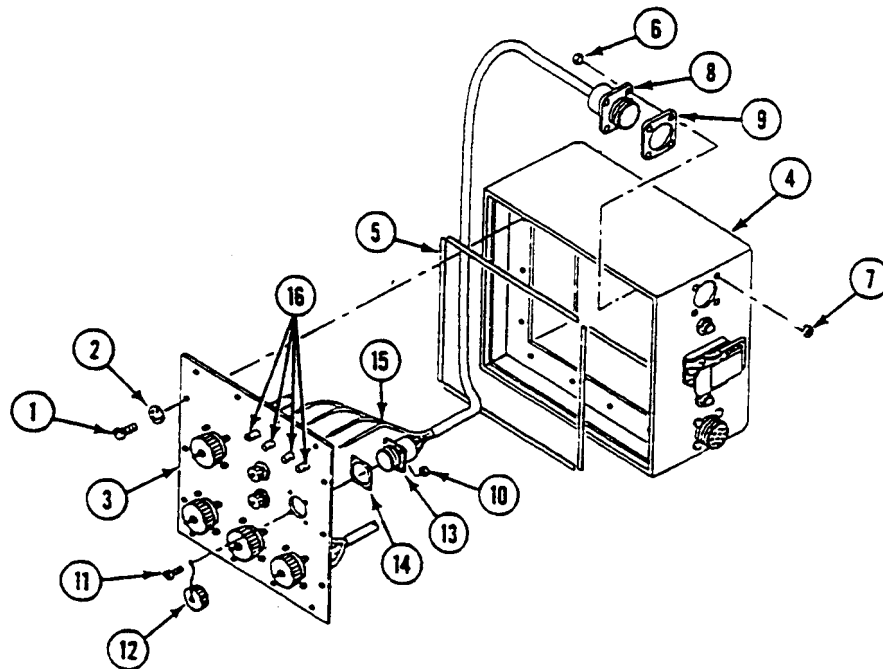

NOTE

Do not remove gasket unless gasket is damaged.

2. If any of four gaskets (5) are damaged, remove only the damaged gaskets from box (4).

NOTE

Tag all leads before disconnecting from connectors. Use wiring diagram page 0096 00-04.

3. Remove four locknuts (6), screws (7), connector (8), and gasket (9) from box (4). Discard locknuts.
4. Remove four locknuts (10), screws (11), dust cap (12), connector J137 (13), and gasket (14) from faceplate (3). Discard locknuts.
5. Disconnect four leads (15) from four binding posts (16).

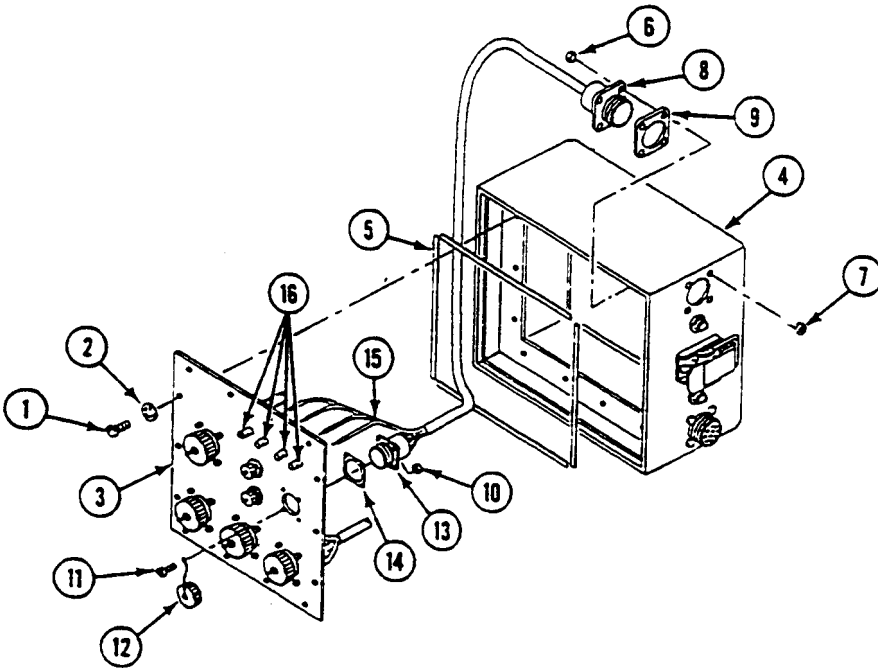

6. Disconnect three lead terminals (1) from connector J11 (2).
7. Disconnect three terminals (1) from connector J12 (3).
8. Disconnect three lead terminals (1) from connector J13 (4).
9. Remove 12 screws (5), locknuts (6), three dust caps (7), connectors (2), (3), and (4), and gaskets (8) from faceplate (9). Discard locknuts.
10. Remove four screws (5), locknuts (6), J7 connector (10), and gasket (11) from box (12). Discard locknuts.
11. Remove two jamnuts (13) and connectors J9 and J10 (14) from box (12).
12. Remove two jamnuts (15) and connectors J113 and J114 (16) from faceplate (9).
13. Remove four screws (5), locknuts (6), connector J22 (17), gasket (18), and dust cap (19) from faceplate (9). Discard locknuts.
14. Remove four binding posts (20) from faceplate (9).
15. Remove two locknuts (21), screws (22), and caps (23) from faceplate (9). Discard locknuts.
16. Remove six nuts (24), screws (25), washers (26), two catch assemblies (27), and pads (28) from box (12).

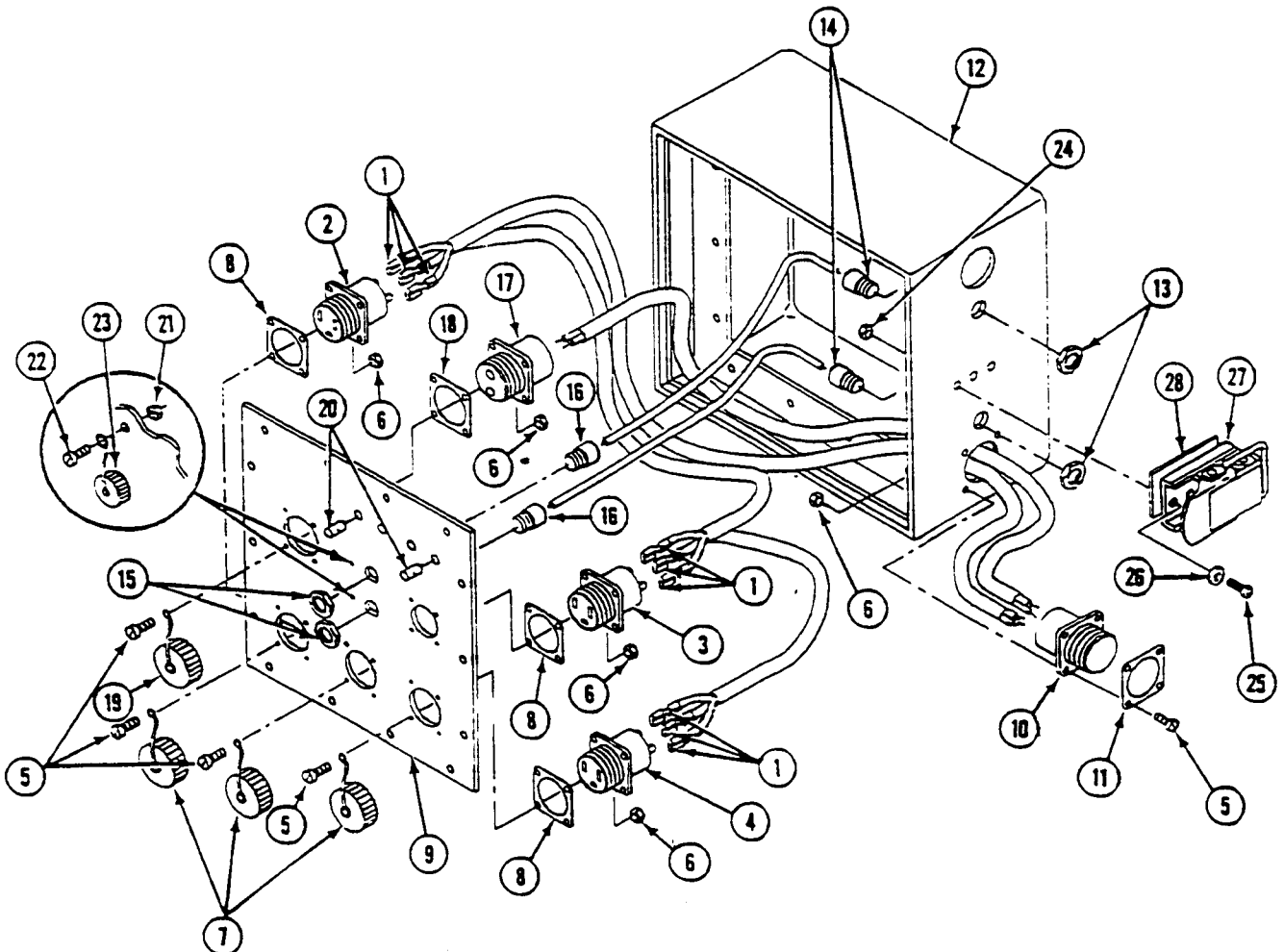

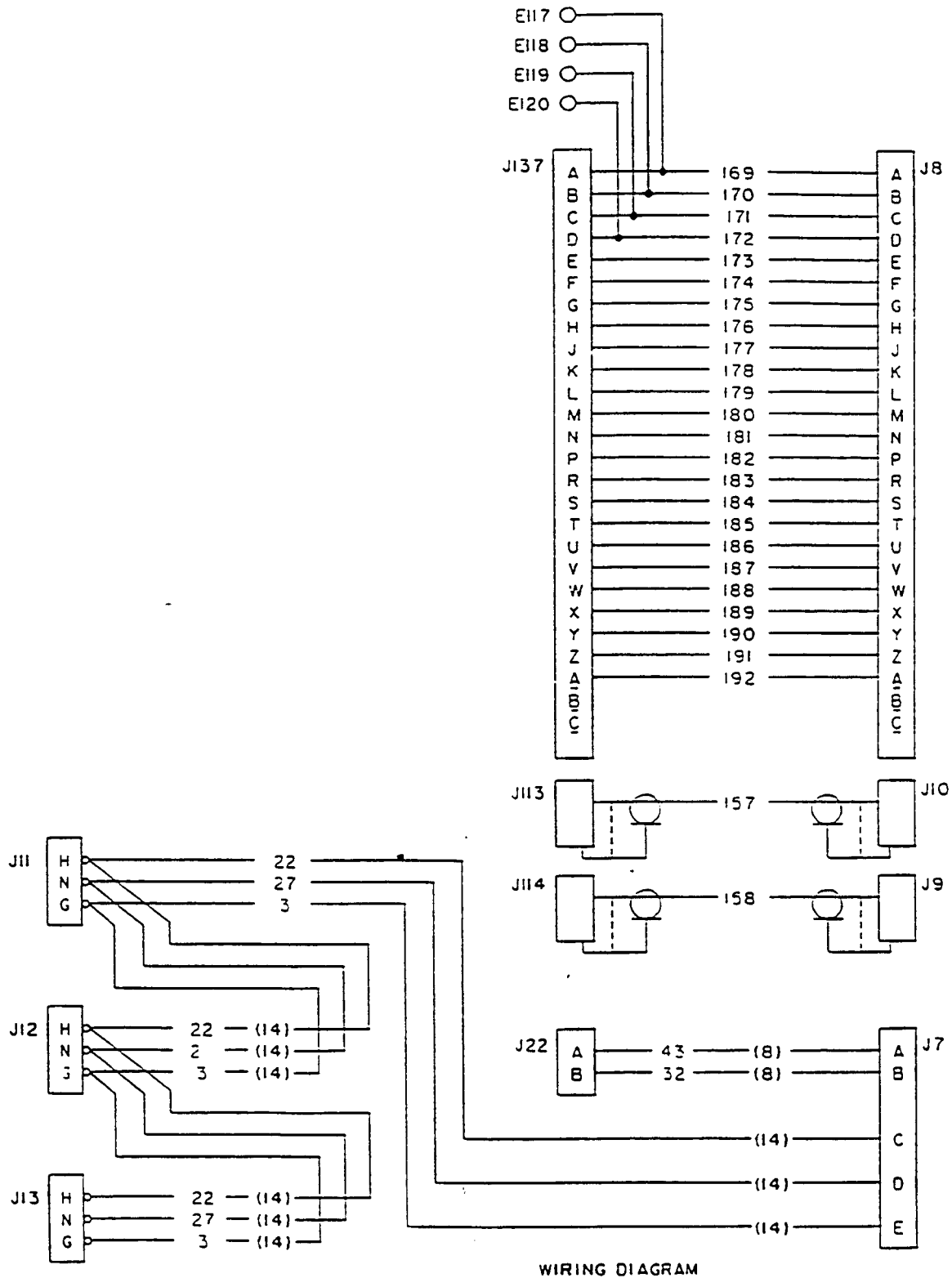

ASSEMBLY

1. Install two catch assemblies (1), pads (2), six screws (3), washers (4), and nuts (5) on box (6).
2. Install two caps (7), screws (8), and new locknuts (9) on faceplate (10).
3. Install four binding posts (11) on faceplate (10).
4. Install connector J22 (12), gasket (13), dust cap (14), four screws (15), and new locknuts (16) on faceplate (10).
5. Install two connectors J113 and J114 (17) and jamnuts (18) on faceplate (10).
6. Install two connectors J9 and J10 (19) and jamnuts (20) on box (6).
7. Install connector J7 (21), gasket (22), four screws (15), and locknuts (16) on box (6).
8. Install three connectors (23)(24)(25), gaskets (26), dust caps (27), 12 screws (15), and new locknuts (16) on faceplate (10).

NOTE

Use wiring diagram page 0096 00-04.

9. Connect three lead terminals (28) on connector J13 (23).
10. Connect three lead terminals (28) on connector J12 (24).

11. Connect three lead terminals (28) on connector J11 (25).

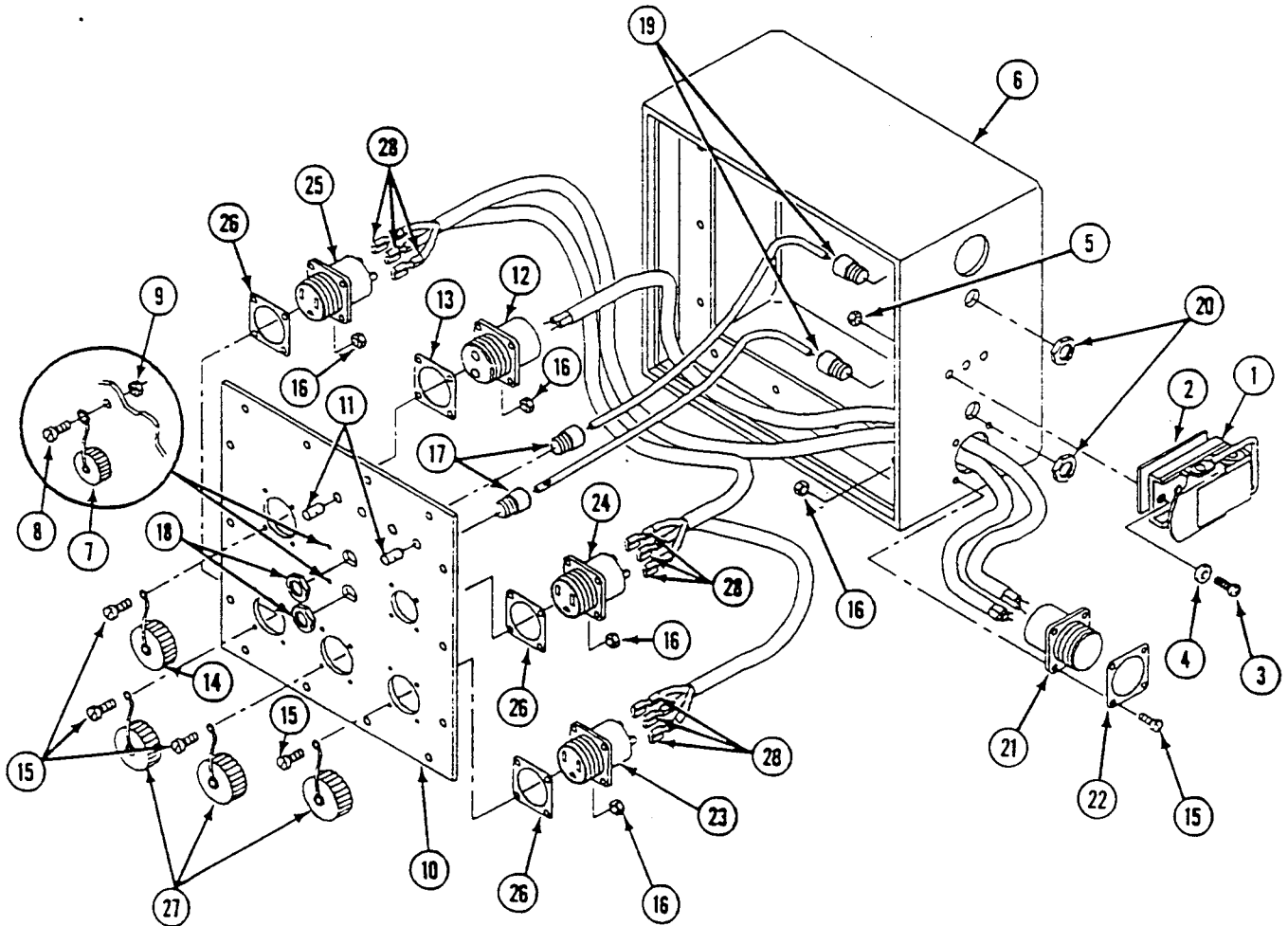

12. Install four leads (1) on four binding posts (2).
13. Install connector J137 (3), gasket (4), dust cap (5), four screws (6), and new locknuts (7) on faceplate (8).
14. Install connector J8 (9), gasket (10), four screws (11), and new locknuts (12) on box (13).
15. Install new gaskets (14) by applying a thin coat of adhesive to box surface and to gasket surface. Allow 10 to 20 minutes to dry (tacky to the touch). Position gasket on box (13) and press firmly into place.
16. Install faceplate (8), 14 new lockwashers, (15) and screws (16) on box (13).

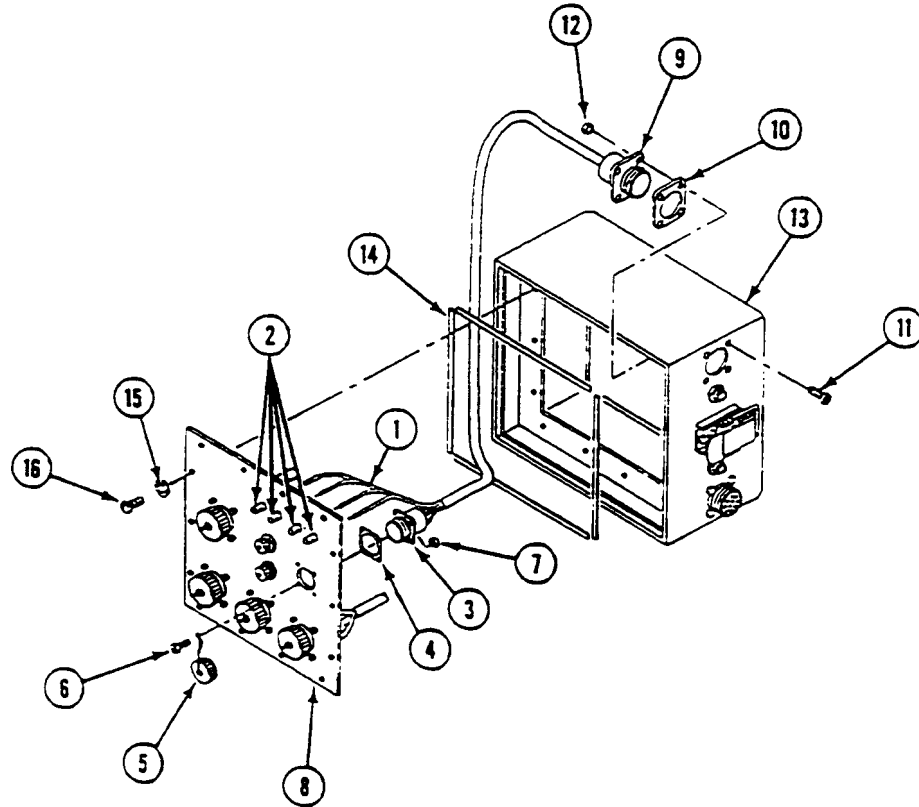

FOLLOW-THROUGH STEPS

1. Install tent interface panel box assembly (see your -20).

END OF TASK

REPAIR AC POWER EXTENSION BOXES A6 AND A7 (M1068A3 ONLY)

0097 00

THIS WORK PACKAGE COVERS:

Disassembly (page 0097 00-1).
 Assembly (page 0097 00-3).

INITIAL SETUP:

Maintenance Level

Direct Support

Personnel Required

Fuel and Elec Sys Rep 63G10

Tools and Special Tools

Automotive Fuel and Electrical System Repair Tool Kit
 (WP 0120 00, Item 59)

References

See your -10
 See your -20

Materials/Parts

Self-locking nut (40)

Equipment Condition

AC power extension box A6 removed (see your -20)
 AC power extension box A7 removed (see your -20)

DISASSEMBLY

NOTE

Mechanical Disassembly/Assembly are the same for A6 and A7. Electrical reference designators are different. Use Wiring Diagrams page 0097 00-4 for reassembly.

1. Remove four screws (1), cover (2), and gasket (3), from extension box (4).

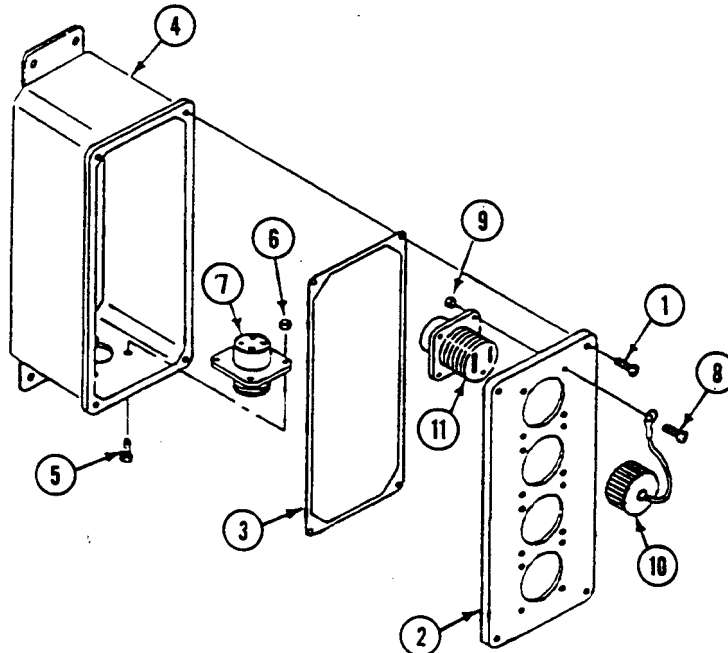

NOTE

Tag all leads before disconnecting for proper assembly later.

2. Remove four screws (5), locknuts (6), and connector J1 (7) from extension box (4). Discard locknuts.
3. Disconnect leads from connectors if necessary.
4. Remove sixteen screws (8), locknuts (9), four dust caps (10), and connectors (11) from cover (2). Discard locknuts.

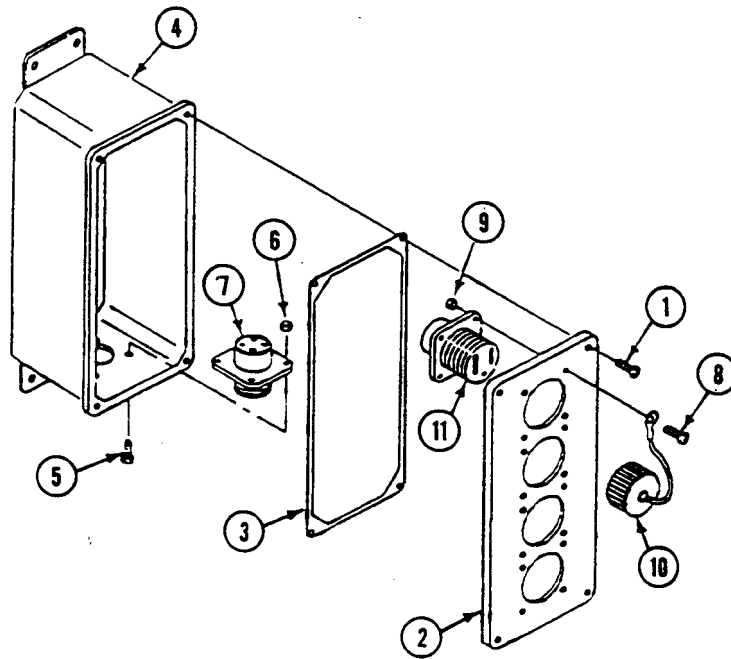

ASSEMBLY

1. Install four connectors (1), dust caps (2), on cover (3) and secure with sixteen screws (4) and new locknuts (5).
2. Install connector J1 (6) on extension box (7) and secure with four screws (8) and new locknuts (9).
3. Connect leads to connectors if necessary.
4. Install gasket (10), cover (3), on extension box (7) and secure with four screws (11).

NOTE

Color Designation for Terminals:

H (HOT) = YELLOW

N (NEUTRAL) = WHITE

G (GROUND) = GREEN

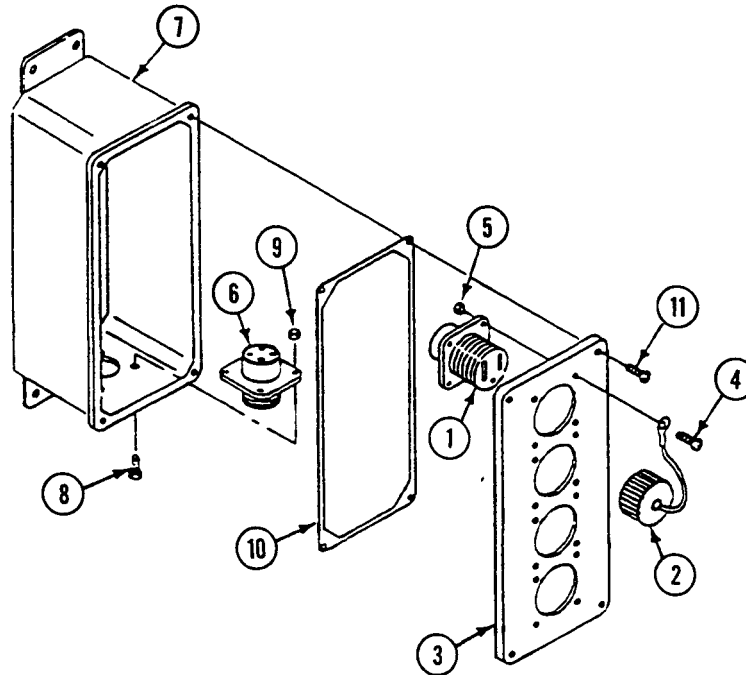

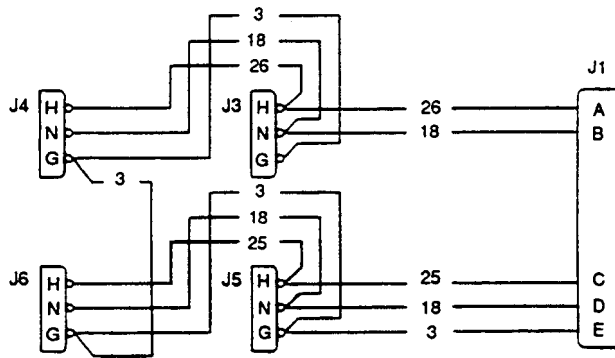

12383854-1 (A6) WIRING DIAGRAM

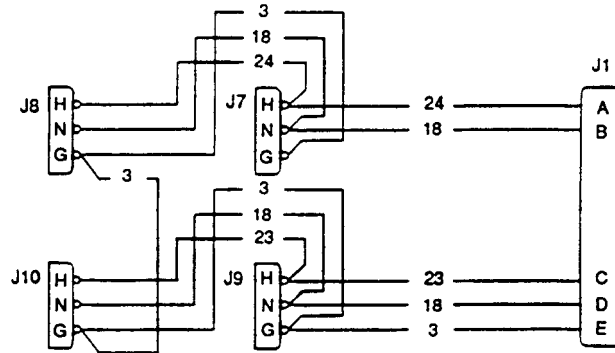

12383854-2 (A7) WIRING DIAGRAM

FOLLOW-THROUGH STEPS

1. Install AC power extension A6 box (see your -20).
2. Install AC power extension A7 box (see your -20).

END OF TASK

REPAIR ROADSIDE DC POWER EXTENSION BOX A9 (M1068A3 ONLY)

0098 00

THIS WORK PACKAGE COVERS:

Disassembly (page 0098 00-1).
 Assembly (page 0098 00-3).

INITIAL SETUP:

Maintenance Level

Direct Support

Personnel Required

Fuel and Elec Sys Rep 63G10

Tools and Special Tools

Automotive Fuel and Electrical System Repair Tool Kit
 (WP 0120 00, Item 59)

References

See your -20

Materials/Parts

Locknut (28)

Equipment Condition

Roadside DC power extension box
 removed (see your -20)

DISASSEMBLY

NOTE

See wiring diagram page 0098 00-4 for assemble/disassemble of wires to connectors.

1. Remove four screws (1), cover (2) and gasket (3) from extension box (4).

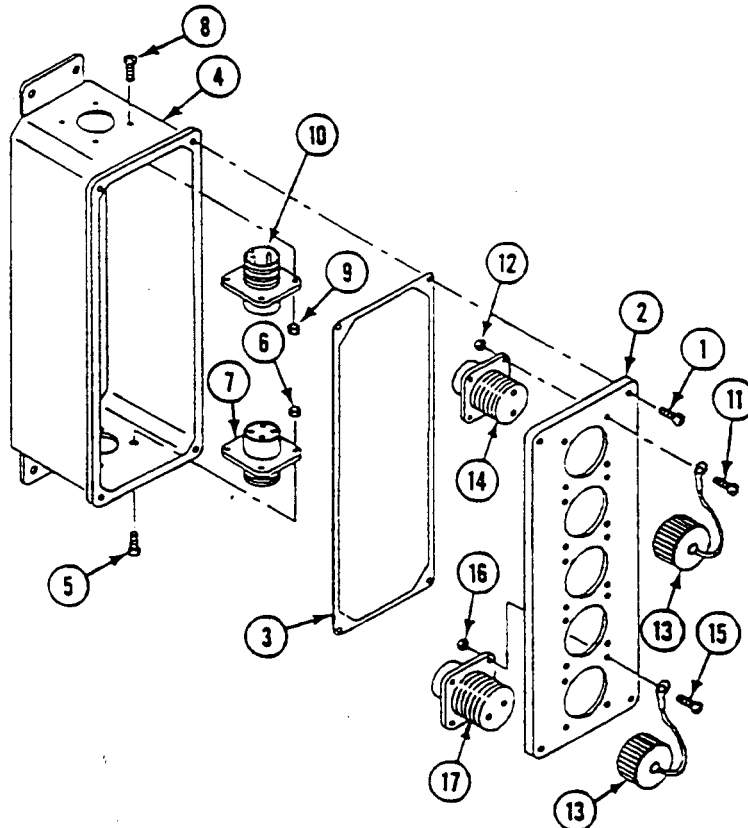

NOTE

Tag all leads before disconnecting for proper assembly later.

2. Remove four screws (5), locknuts (6), and connector J1 (7) from extension box (4). Discard locknuts.
3. Remove four screws (8), locknuts (9), and connector J2 (10) from extension box (4). Discard locknuts.
4. Remove sixteen screws (11), locknuts (12), four dust caps (13), and four connectors J18-J21 (14) from cover (2). Discard locknuts.
5. Remove four screws (15), locknuts (16), dust cap (13), and connector J23 (17) from cover (2). Discard locknuts.
6. Disconnect leads from connectors if necessary.

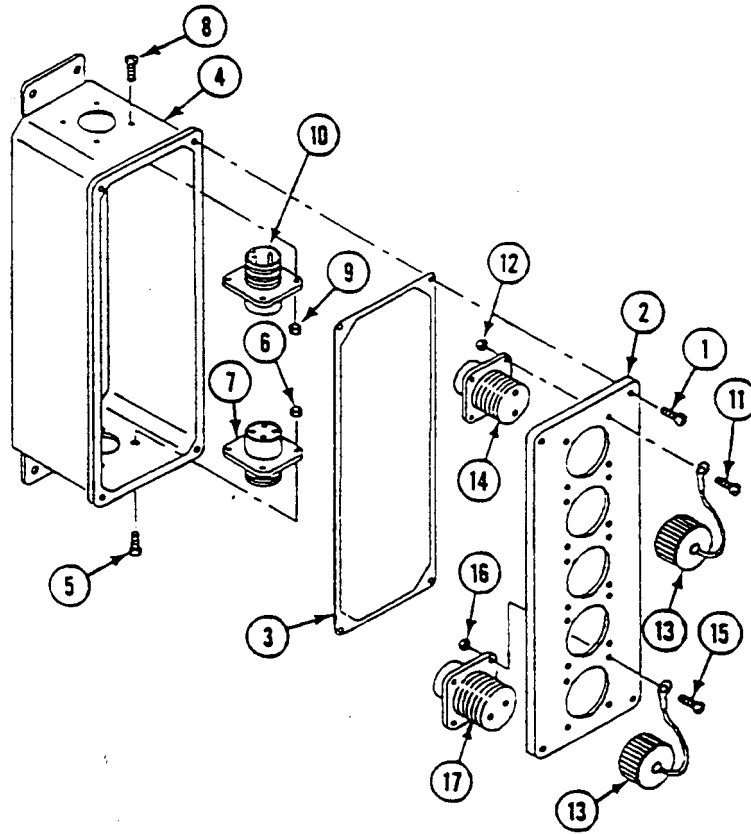

ASSEMBLY

NOTE

See wiring diagram page 0098 00-4 for assemble/disassemble of wires to connectors.

1. Install connector J23 (17) on cover (2) with dustcap (13), secure with four screws (15) and new locknuts (16).
2. Install four connectors J18-J21 (14) on cover (2) with dust caps (13), secure with sixteen screws (11) and new locknuts (12).
3. Install connector J2 (10) on extension box (4), secure with four screws (8) and new locknuts (9).
4. Install connector J1 (7) on extension box (4), secure with four screws (5) and new locknuts (6).
5. Connect leads to connectors if necessary.
6. Install cover (2) on extension box (4) with gasket (3) and secure with four screws (1).

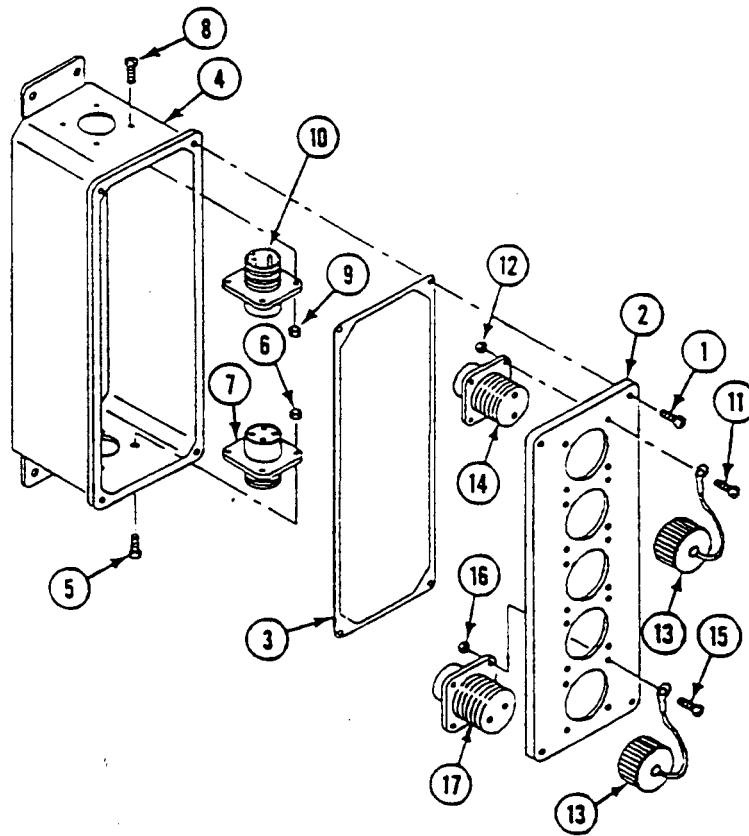

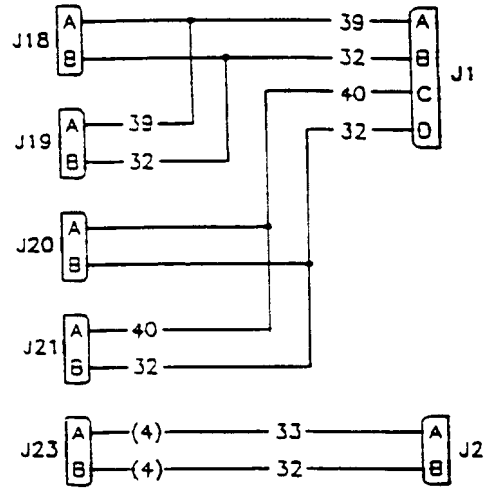

(A9) WIRING DIAGRAM

FOLLOW-THROUGH STEPS

1. Install roadside DC power extension box (see your -20).

END OF TASK

REPAIR SIGNAL PATCH PANEL BOX A10 (M1068A3 ONLY)

0099 00

THIS WORK PACKAGE COVERS:

Disassembly (page 0099 00-1).
 Assembly (page 0099 00-4).

INITIAL SETUP:

Maintenance Level
 Direct Support

Personnel Required
 Radio Repairer 29E10

Tools and Special Tools
 Electronic Equipment Tool Kit (WP 0120 00, Item 61)

References
 See your -20

Materials/Parts
 Sealing compound (WP 0122 00, Item 25)
 Adhesive primer (WP 0122 00, Item 23)
 Lockwasher (as required)
 Locknut (20)
 Rivet (as required)

Equipment Condition
 Signal patch panel box removed (see your -20)

DISASSEMBLY

1. Remove twelve screws (19), lockwashers (18), two strips (17), and three jackfields (9) from signal patch panel box (2).

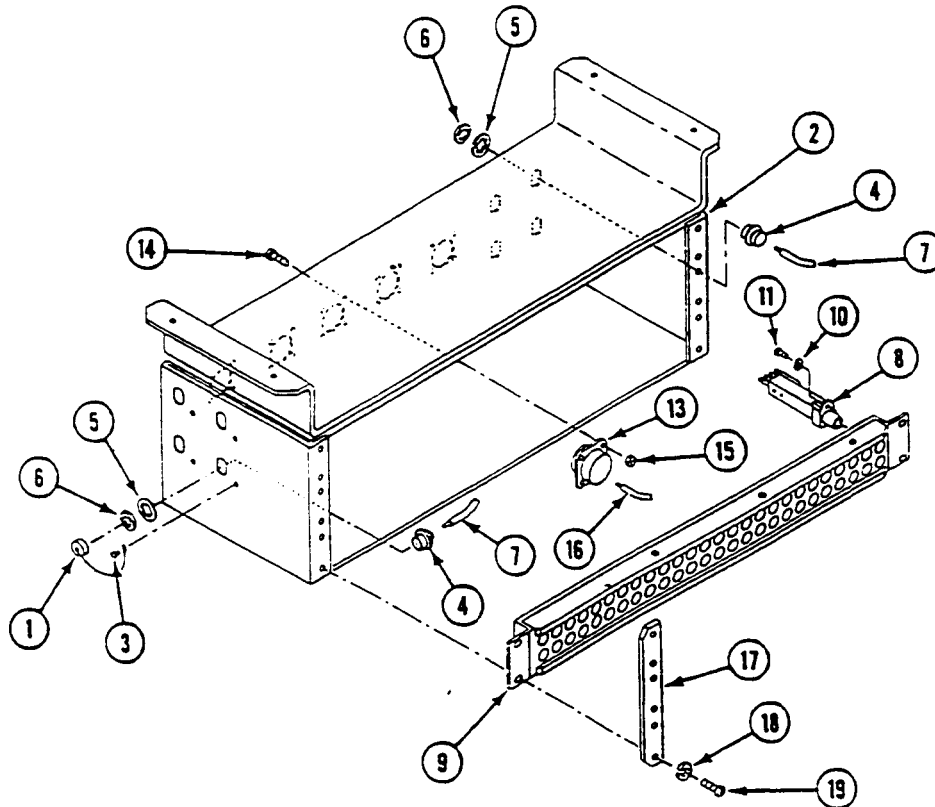

NOTE

Tag all wires/leads before removal, use wiring diagram page 0099 00-3.

2. Remove twenty locknuts (15), screws (14), and five connectors J135, J136, J138, J139, and J140, (13) from signal patch panel box (2). Discard locknuts.
3. Disconnect wires (16) from five connectors J135, J136, J138, J139, and J140 (13).
4. Remove screws (11), lockwashers (10), and 156 jacks (8) from three jackfields (9). Discard lockwashers.
5. Remove two leads from each jack (8).
6. Remove jamnuts (6), lockwashers (5), and eight connectors (4) from signal patch panel box (2).
7. Remove wires (7) from eight connectors (4).
8. If dust caps (1) are damaged, remove rivets (3) and dust caps from signal patch panel box (2).

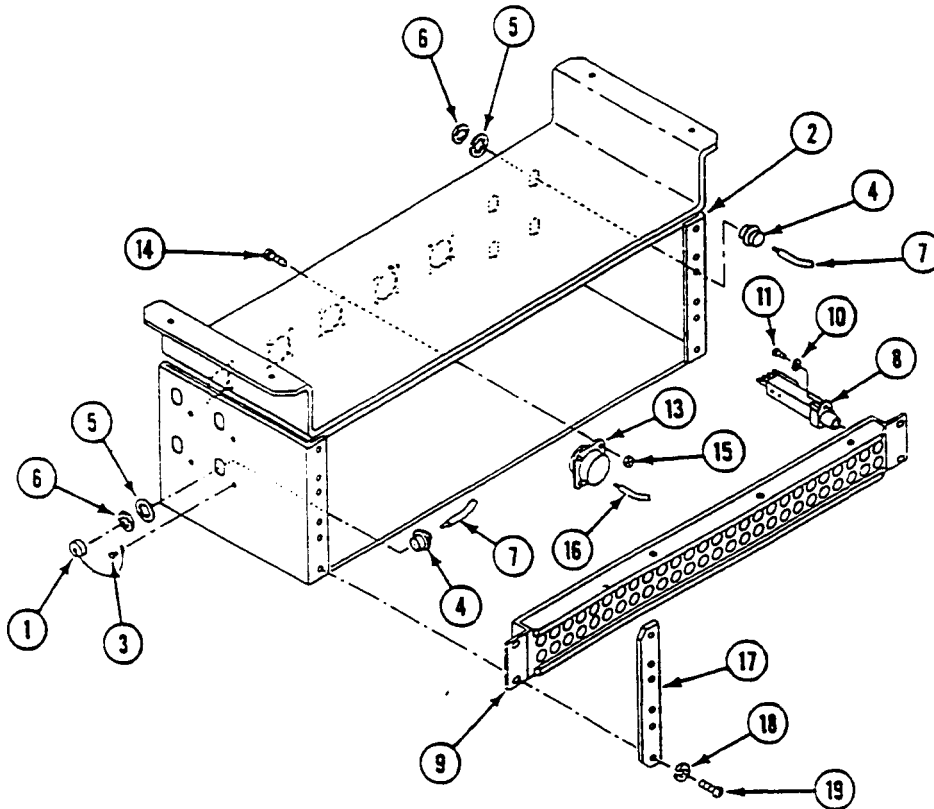

REPAIR SIGNAL PATCH PANEL BOX A10 (M1068A3 ONLY) — Continued

0099 00

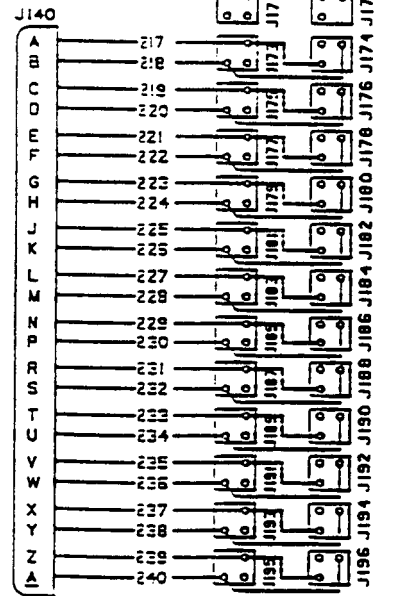
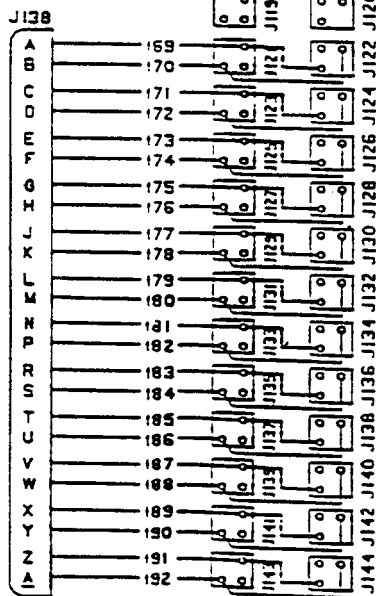
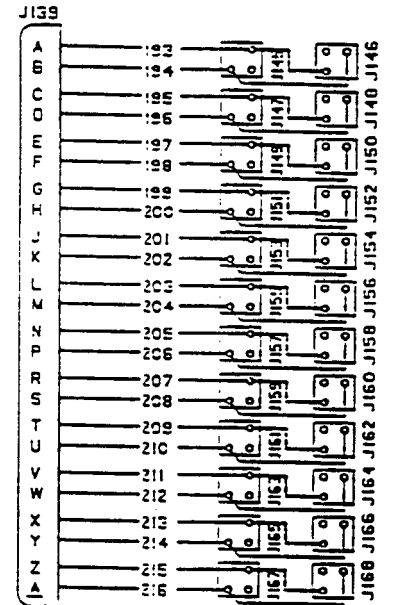
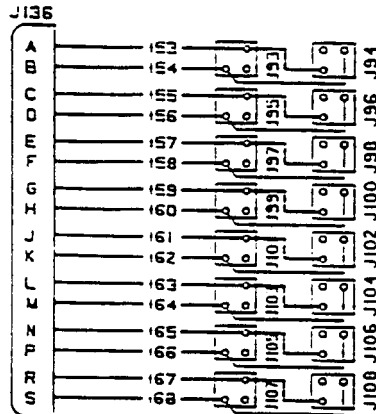
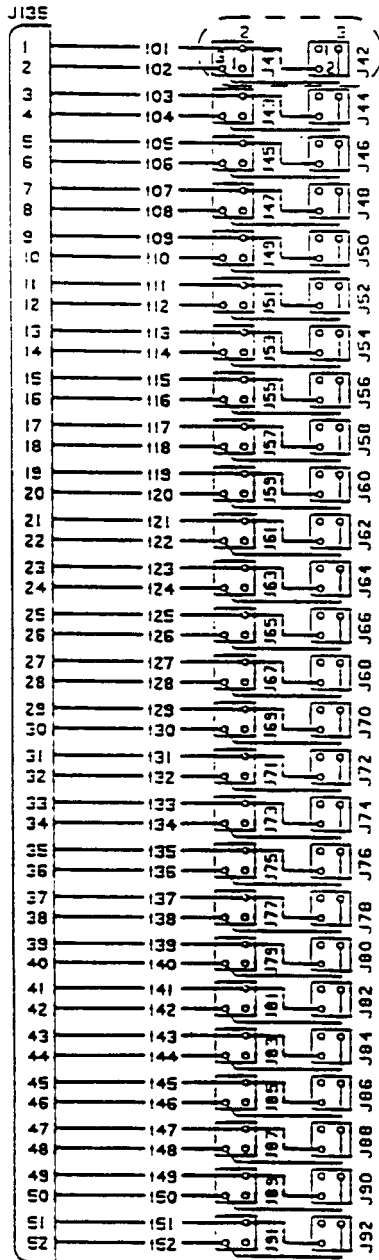
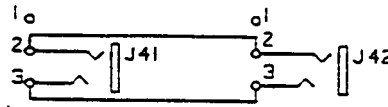

ASSEMBLY

1. If dust caps (1) were removed, install dust caps on signal patch panel box (2) and secure with new rivets (3).
2. Install eight connectors (4) on signal patch panel box (2), secure with lockwashers (5) and jamnuts (6).

NOTE

Install wires (7) on eight connectors (4) using wiring diagram page 0099 00-3.

Apply primer and sealant to threads of screws (11).

3. Install 156 jacks (8) on three jackfields (9), secure with new lockwashers (10) and screws (11).

NOTE

Install two leads (12) on each jack (8) using wiring diagram page 0099 00-3.

4. Install five connectors J135, J136, J138, J139, and J140 (13) on signal patch panel box (2), secure with twenty screws (14) and new locknuts (15).

NOTE

Install wires (16) on five connectors J135, J136, J138, J139, and J140 (13), using wiring diagram page 0099 00-3.

5. Install three jackfields (9) on signal patch panel box (2), secure with two strips (17), twelve new lockwashers (18), and screws (19).

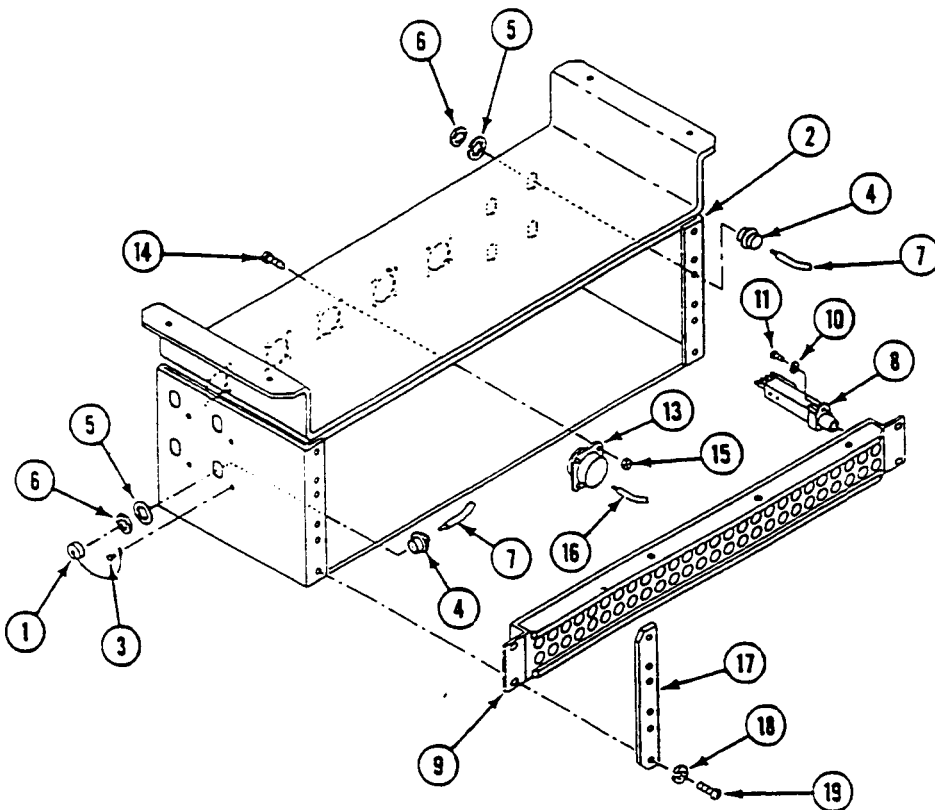

FOLLOW-THROUGH STEPS

1. Install signal patch panel box (see your -20).

END OF TASK

REPAIR EXTERNAL COMMUNICATION BOX A11 (M1068A3 ONLY)

0100 00

THIS WORK PACKAGE COVERS:

Disassembly (page 0100 00-2).
Assembly (page 0100 00-5).

INITIAL SETUP:

Maintenance Level

Direct Support

Personnel Required

Radio Repairer 29E10

Tools and Special Tools

■ Electronic Equipment Tool Kit (WP 0120 00, Item 61)

References

See your -20

Materials/Parts

Locknut (8)

Locknut (8)

Locknut (4)

Locknut (2)

Lockwasher (22)

Equipment Condition

External communication box removed (see your -20)

DISASSEMBLY

1. Remove four screws (13), locknuts (14), and two latches (15) from communication box (2). Discard locknuts.
2. Remove four screws (13), locknuts (14), and two catches (12) from communication box lid (1). Discard locknuts.
3. Remove four screws (10), locknuts (11), and latch half (9) from lid (1). Discard locknuts.
4. Remove four screws (7), locknuts (8), and latch half (6) from communication box (2). Discard locknuts.
5. Remove two screws (3), four washers (4), two locknuts (5), and lid (1) from communication box (2). Discard locknuts.

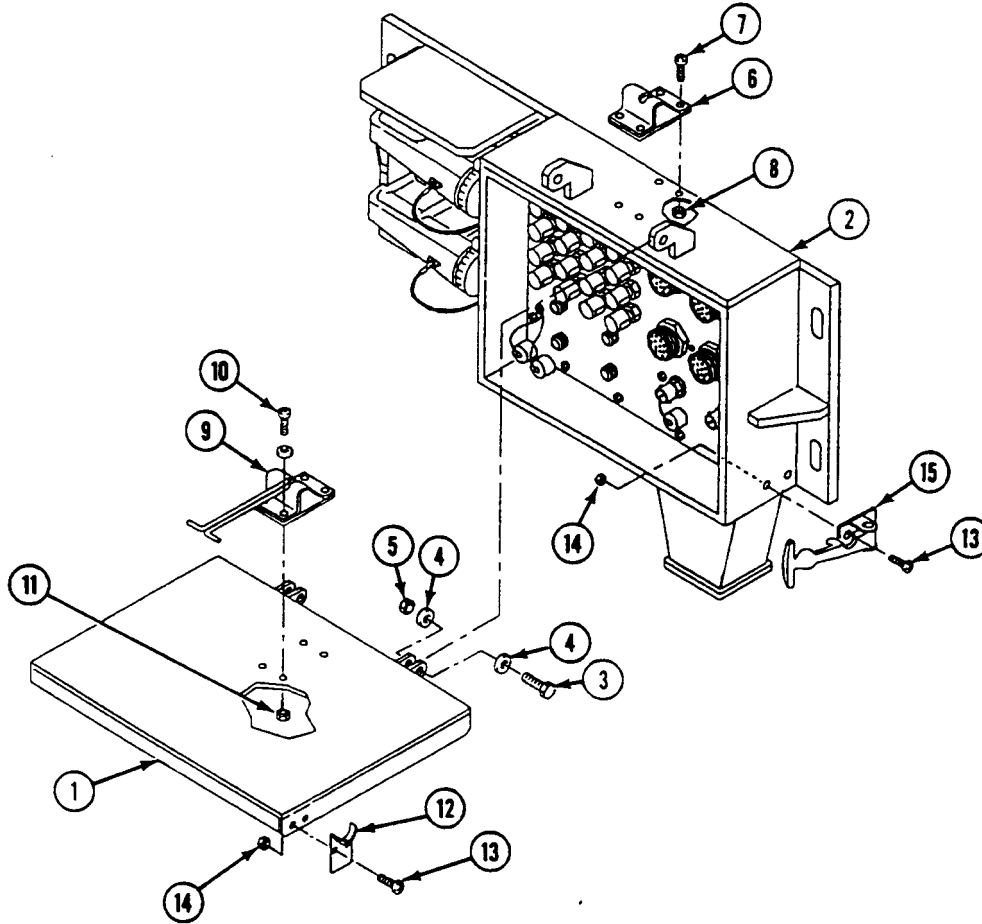

NOTE

See wiring diagram, (page 0100 00-4) for assembly/disassembly of wires to connectors.
Tag leads/cables before removing/disconnecting. Replace pads only if damaged.

NOTE

If cable W118 is being replaced, remove connector (6) before discarding.

6. Remove twelve screws (1), lockwashers (2), cable W117 (3), and cable W118 (4) from communication box (5). Discard lockwashers.
7. Remove fourteen screws (7), lockwashers (8), and faceplate (9) from communication box (5). Discard lockwashers.
8. Remove two screws (10), locknuts (11), and four caps (12) from faceplate (9). Discard locknuts.
9. Remove two screws (13), locknuts (14), and caps (15) from faceplate (9). Discard locknuts.
10. Remove four cables (16) from faceplate (9).
11. Loosen sixteen binding posts (17) and remove cable W115 (18).
12. Remove four connectors (19) and four cables (20) from faceplate (9).
13. Remove two nuts (21), four bushings (22), cable W101 (23), and cable W102 (24) from faceplate (9).

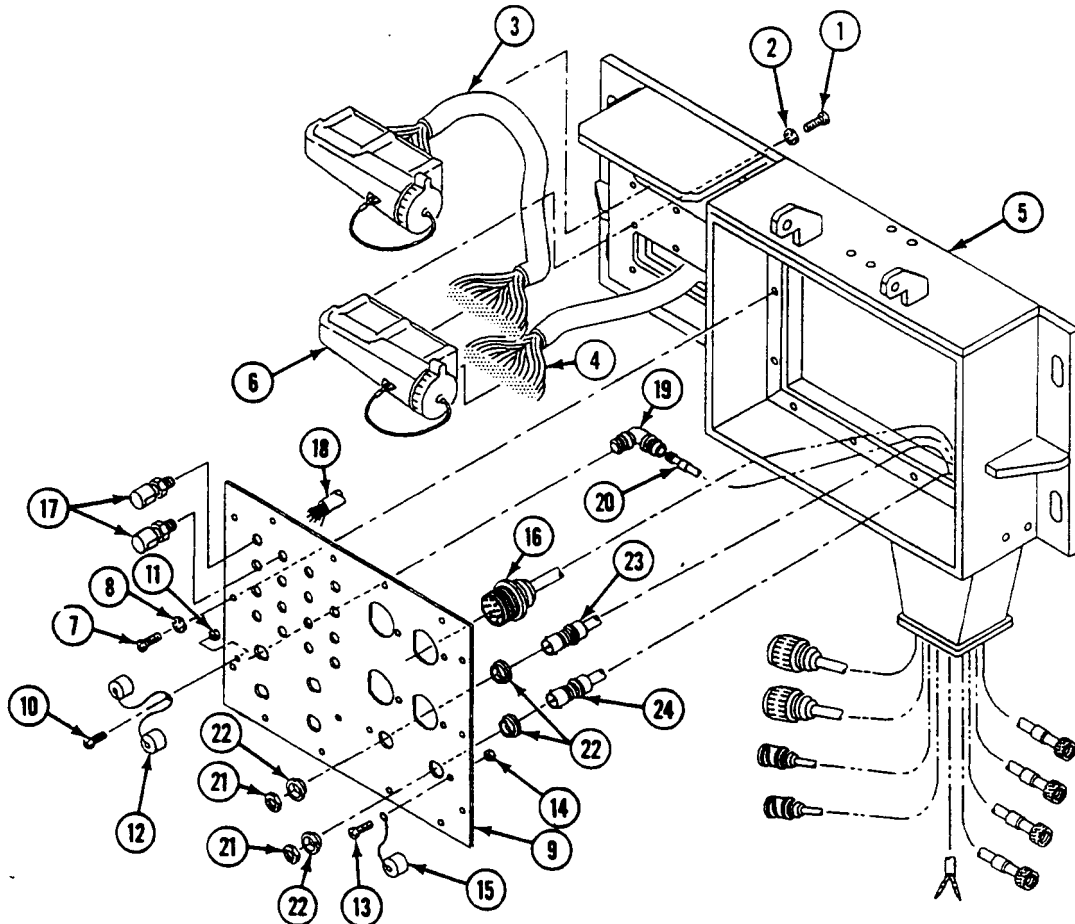

WIRING DIAGRAM

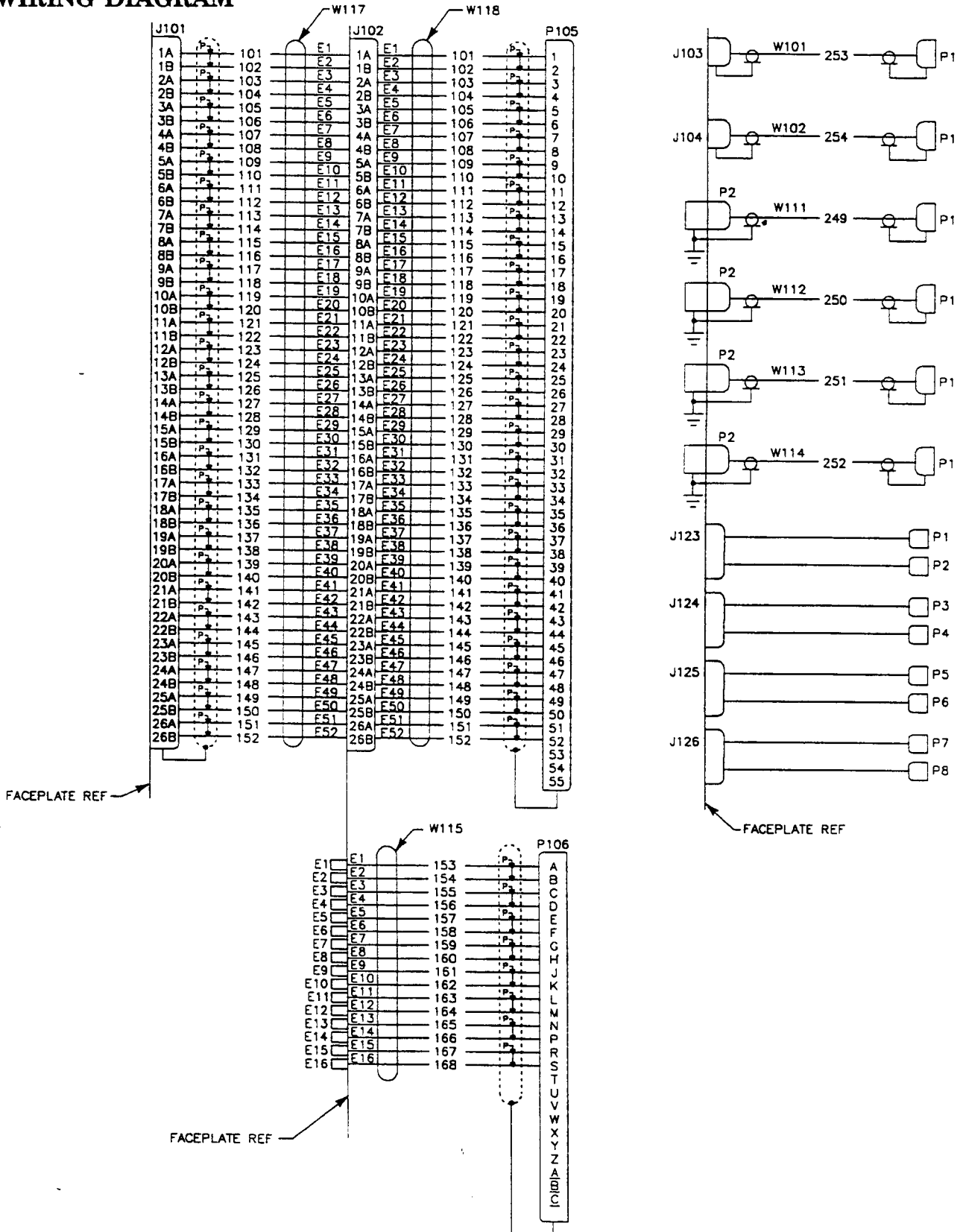

ASSEMBLY

NOTE

See wiring diagram, (page 0100 00-4) for assembly/disassembly of wires to connectors.

1. Install cable W101 (23), cable W102 (24) on faceplate (9) and secure with four bushings (22) and two nuts (21).
2. Install four cables (20) and connectors (19) on faceplate (9).
3. Connect cable W115 (18) to sixteen binding posts (17).
4. Install four cables (16) on faceplate (9).
5. Install two caps (15) on faceplate (9) and secure with two screws (13) and new locknuts (14).

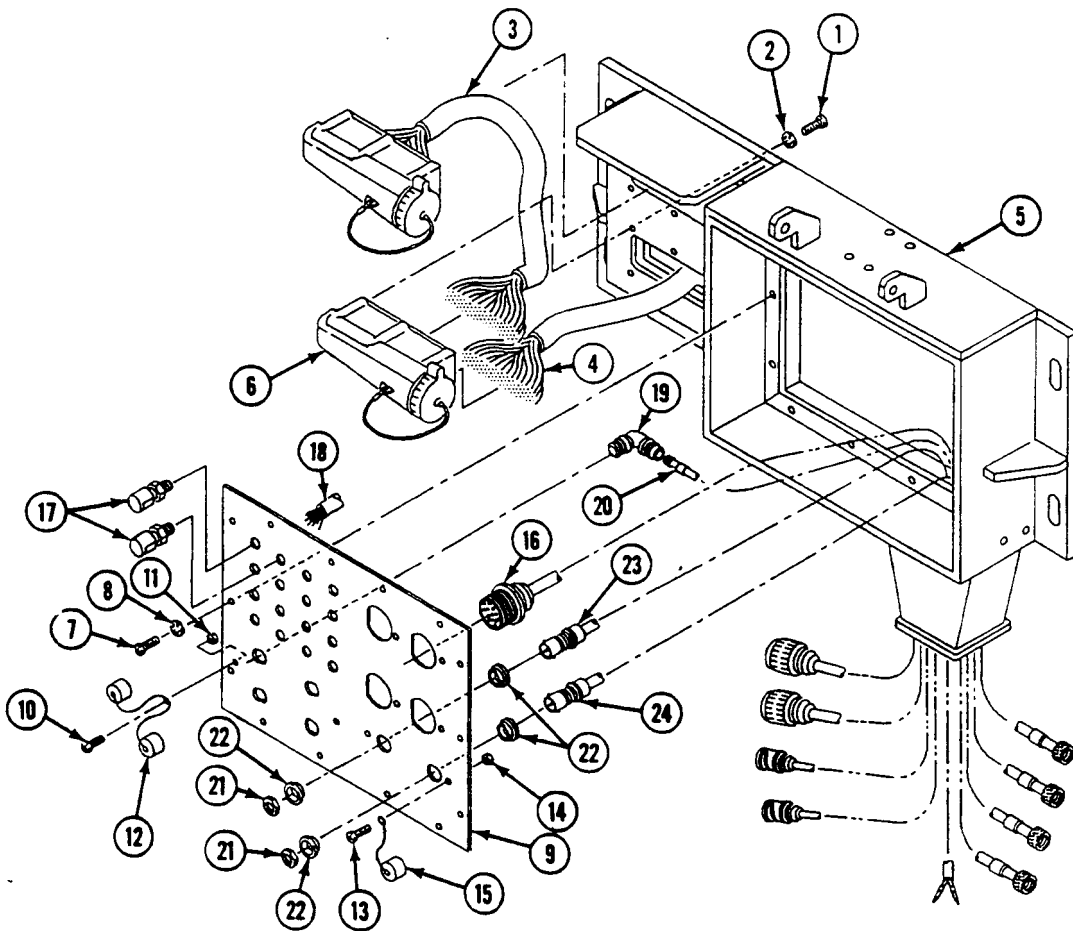

6. Install four caps (12) on faceplate (9) and secure with two screws (10) and new locknuts (11).
7. Install faceplate (9) on communication box (5) and secure with fourteen screws (7) and new lockwashers (8).
8. Install cable W117 (3) and cable W118 (4) on communication box (5) and secure with twelve screws (1) and new lockwashers (2).

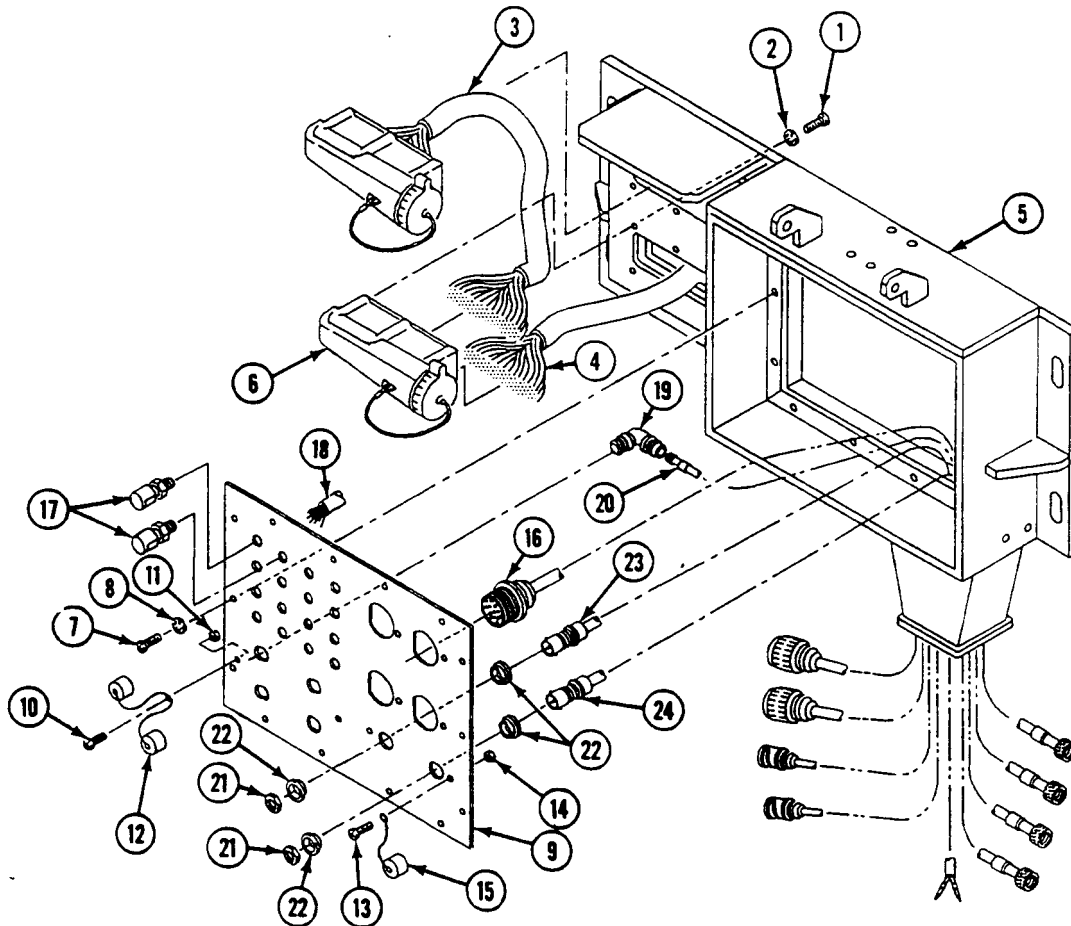

9. Install lid (1) on communication box (2) and secure with two screws (3), four washers (4), and two new locknuts (5).
10. Install latch half (6) on communication box (2) and secure with four screws (7) and new locknuts (8).
11. Install latch (9) on lid (1) and secure with four screws (10) and new locknuts (11).
12. Install two catches (12) on lid (1) and secure with four screws (13) and new locknuts (14).
13. Install two latches (15) on communication box (2) and secure with four screws (13) and new locknuts (14).

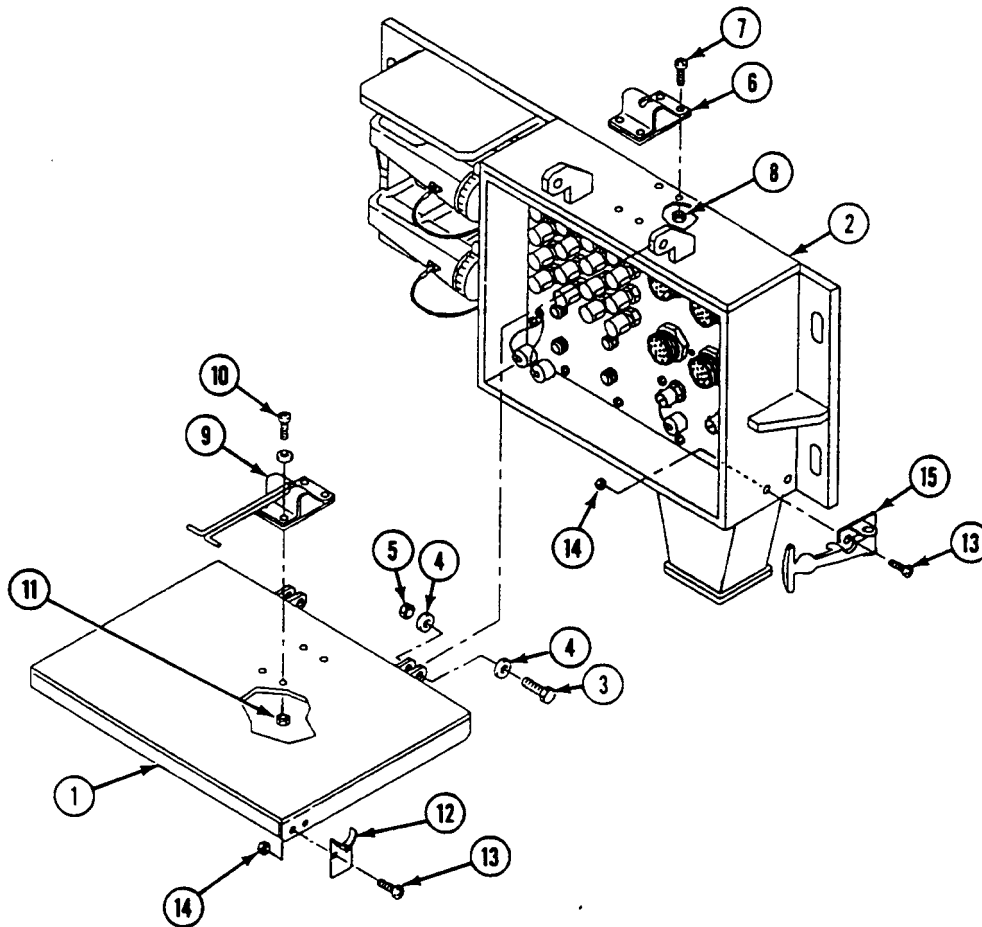
**FOLLOW-THROUGH STEPS**

1. Install external communication box (see your -20).

END OF TASK

**REPAIR ROADSIDE AND CURBSIDE DATA PANEL ASSEMBLIES A12 AND
A13 (M1068A3 ONLY)**

0101 00

THIS WORK PACKAGE COVERS:

Removal (page 0101 00-2).
Installation (page 0101 00-6).

INITIAL SETUP:

Maintenance Level

Direct Support

Personnel Required

Radio Repairer 29E10

Tools and Special Tools

Radio Equipment Tool Kit (WP 0120 00, Item 65)

References

See your -10
See your -20

Materials/Parts

Locknut (4)
Lockwasher (14)

Equipment Condition

Data box removed (see your -20)

REMOVAL

NOTE

Tag all leads before removal for proper installation later.

Follow illustration for removal/installation of red/black binding posts.

See wiring diagrams page 0101 00-4 for disassembly/assembly of wires to connectors/binding posts.

1. Remove 14 screws (1), lockwashers (2), and faceplate (3) from box (4). Discard lockwashers.

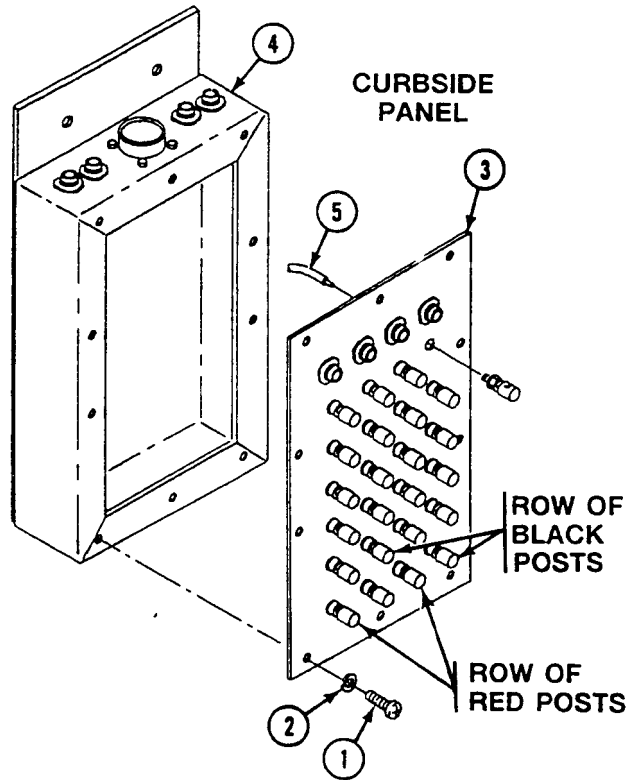

REPAIR ROADSIDE AND CURBSIDE DATA PANEL ASSEMBLIES A12 AND A13
(M1068A3 ONLY) — Continued

0101 00

- Disconnect leads (5) from 24 binding posts (6).

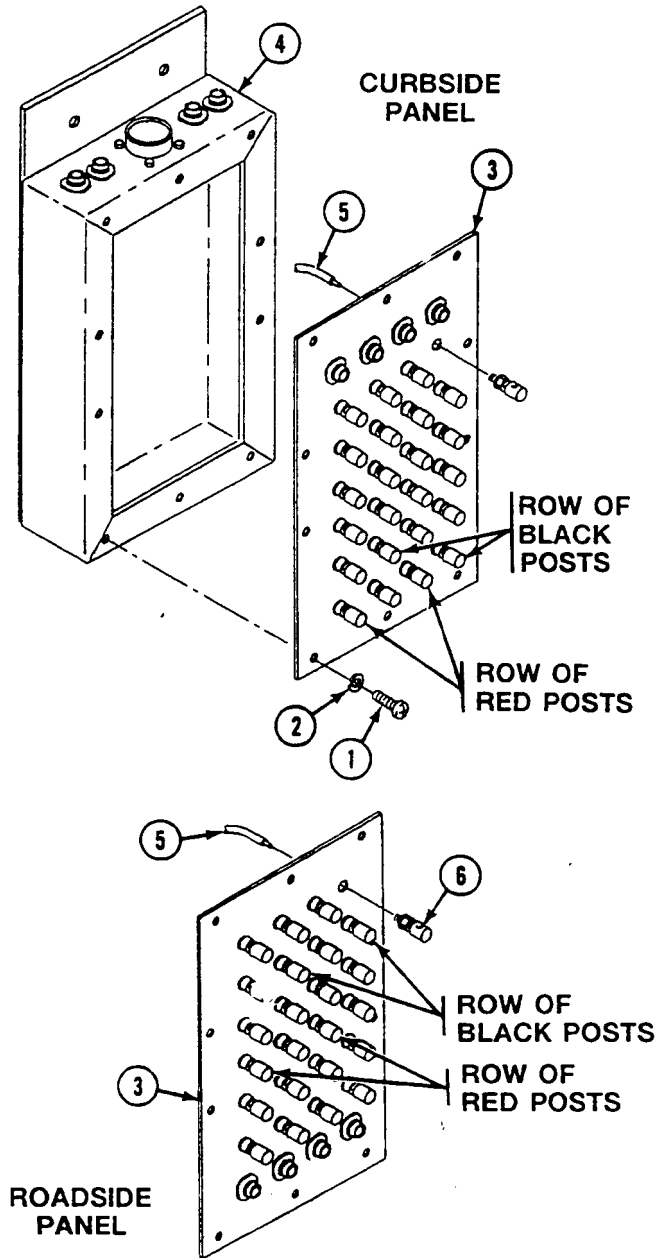

NOTE

Tag all leads before removal for proper installation later.

Follow illustration for removal/installation of red/black binding posts.

See wiring diagrams page 0101 00-4 for disassembly/assembly of wires to connectors/binding posts.

3. Remove four connectors J1, J2, J4, J5 (1), and jamnuts (2) from box (3).

NOTE

Do Step 4 for curbside data panel only. Do Step 5 for roadside data panel only.

4. Remove four connectors J105 thru J108 (4) and jamnuts (2) from faceplate (5).
5. Remove four connectors J109 thru J112 (6) and jamnuts (2) from faceplate (5).
6. Remove four screws (7), locknuts (8), and connector J1 (9) from box (3). Discard locknuts.
7. Remove 24 binding posts (10) from faceplate (5).

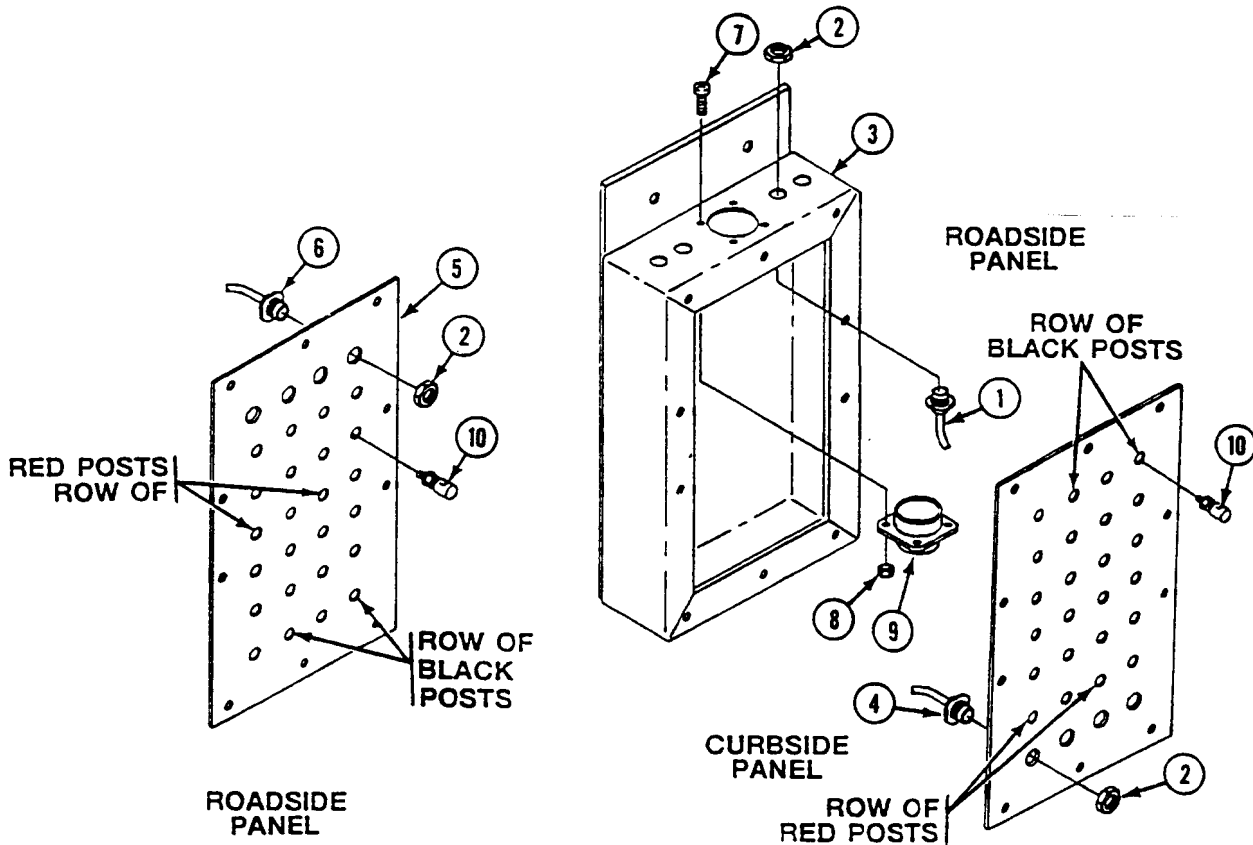

REPAIR ROADSIDE AND CURBSIDE DATA PANEL ASSEMBLIES A12 AND A13
(M1068A3 ONLY) — Continued

0101 00

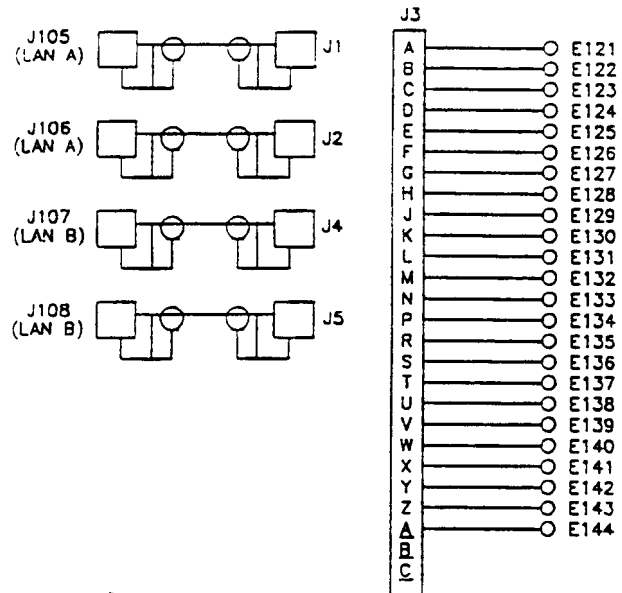

(A12) WIRING DIAGRAM

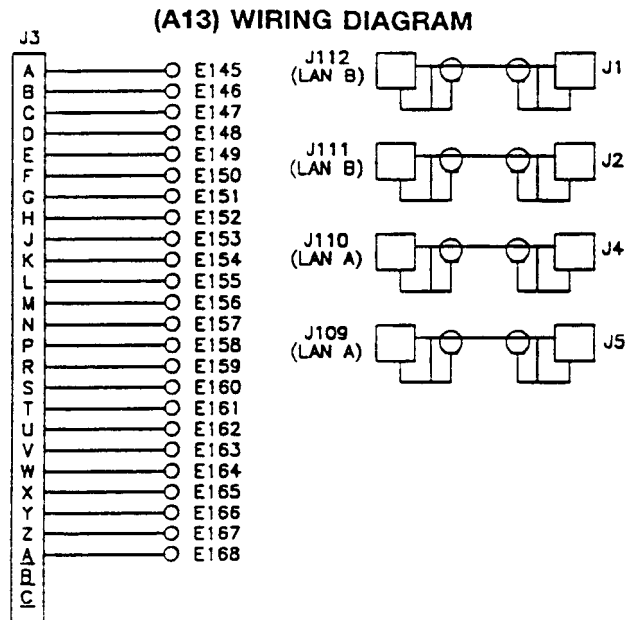

(A13) WIRING DIAGRAM

INSTALLATION

NOTE

See wiring diagrams page 0101 00-4 for assembly/disassembly of wires to connectors/binding posts.

Follow illustration for assembly/disassembly of red/black binding posts.

1. Install 24 binding posts (10) on faceplate (5).
2. Install connector J1 (9) on box (3) and secure with four screws (7) and new locknuts (8).

NOTE

Do Step 3 for roadside data panel only. Do Step 4 for curbside data panel only.

3. Install four connectors J109 thru J112 (6), on faceplate (5) and secure with jamnuts (2).
4. Install four connectors J105 thru J108 (4) on faceplate (5) and secure with jamnuts (2).
5. Install four connectors J1, J2, J4, J5 (1), on box (3) and secure with jamnuts (2).

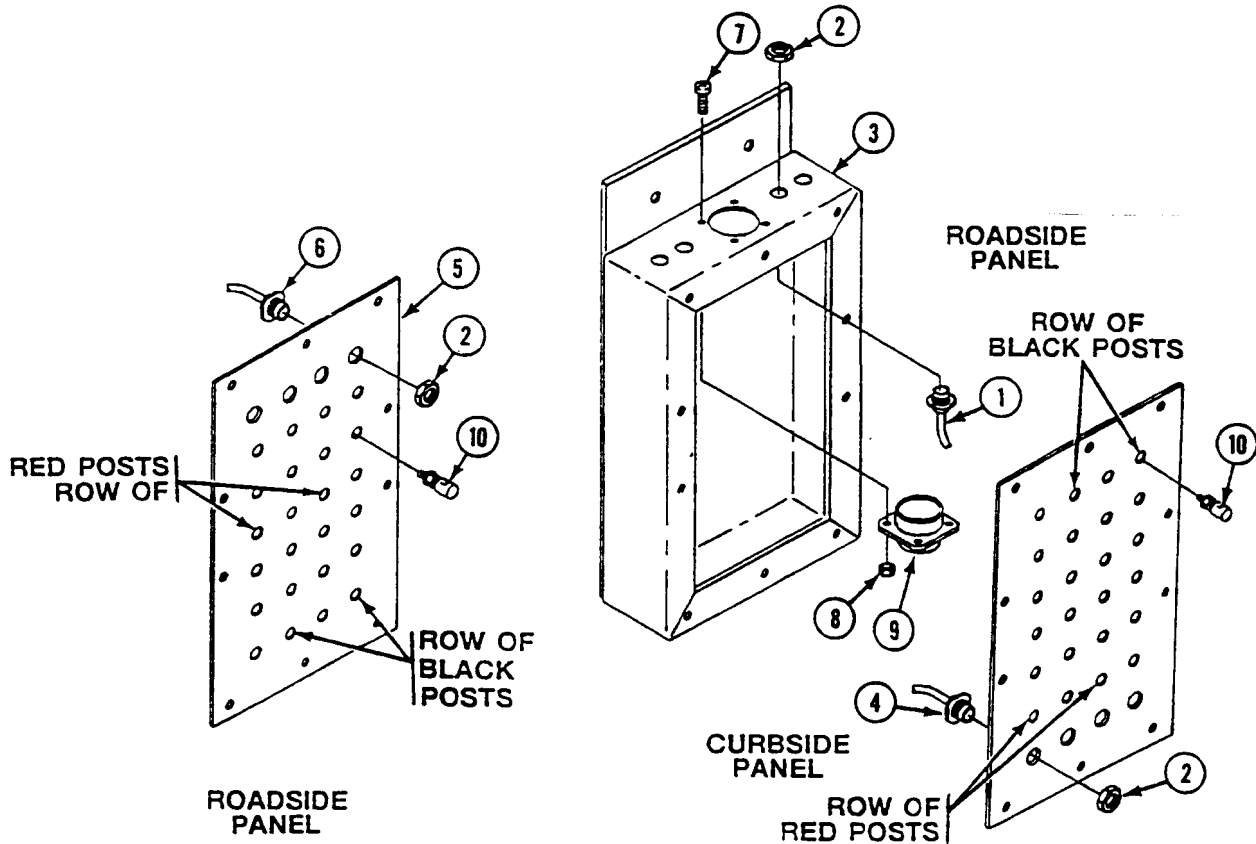

NOTE

See wiring diagram page 0101 00-4 for assembly/disassembly of wires to connectors/binding posts.

Follow illustration for assembly/disassembly of red/black binding posts.

6. Connect leads (5) to 24 binding posts (6).
7. Install faceplate (3) on box (4) and secure with 14 screws (1) new lockwashers (2).

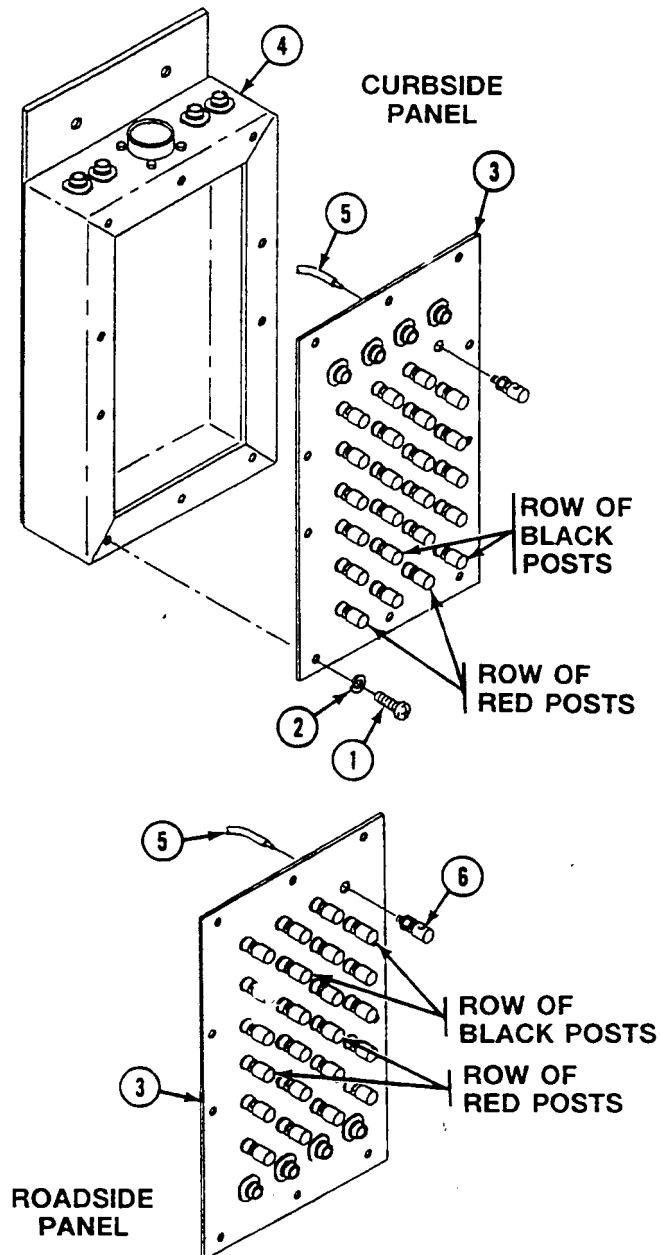

**REPAIR ROADSIDE AND CURBSIDE DATA PANEL ASSEMBLIES A12 AND A13
(M1068A3 ONLY) — Continued**

0101 00

FOLLOW-THROUGH STEPS

1. Install data box (see your -20).

END OF TASK

REPAIR PHONE EXTENSION BOX A14 (M1068A3 ONLY)

0102 00

THIS WORK PACKAGE COVERS:

Disassembly (page 0102 00-1).
 Assembly (page 0102 00-3).

INITIAL SETUP:

Maintenance Level

Direct Support

Personnel Required

Radio Repairer 29E10

Tools and Special Tools

Electronic Equipment Tool Kit (WP 0120 00, Item 61)

References

See your -10
 See your -20

Materials/Parts

Adhesive (WP 0122 00, Item 2)
 Locknut (4)
 Lock washer (12)
 Strap

Equipment Condition

Phone extension box removed from stowage box (see your -20)

DISASSEMBLY

NOTE

Tag all leads before removal.

1. Remove 12 screws (1), lockwashers (2), and faceplate (3) from phone extension box (4). Discard lockwashers.

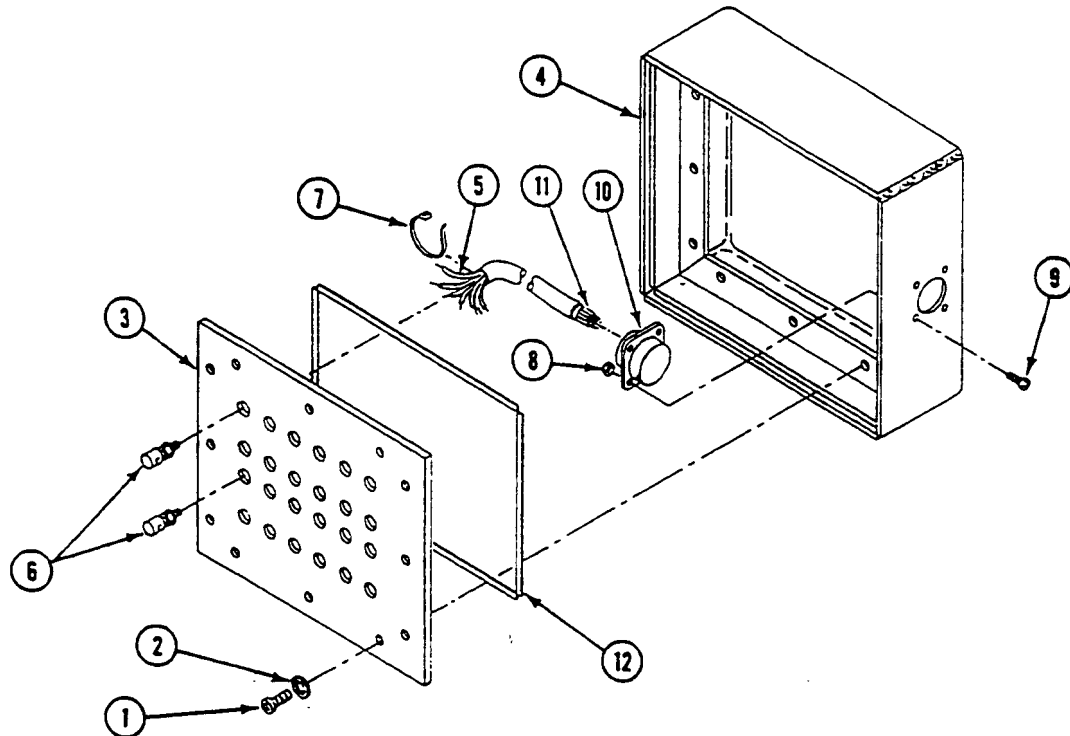

REPAIR PHONE EXTENSION BOX A14 (M1068A3 ONLY) — Continued

0102 00

2. Disconnect all leads (5) from 24 binding posts (6).
3. Remove 24 binding posts (6) from faceplate (3).
4. Remove and discard straps (7), as required.
5. Remove four locknuts (8), screws (9), and connector J1 (10) from phone extension box (4). Discard locknuts.
6. Remove leads (11) from connector J1 (10).
7. Remove any damaged gaskets (12).

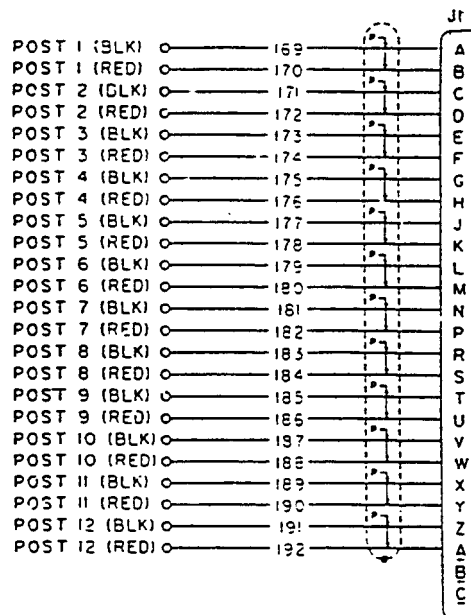
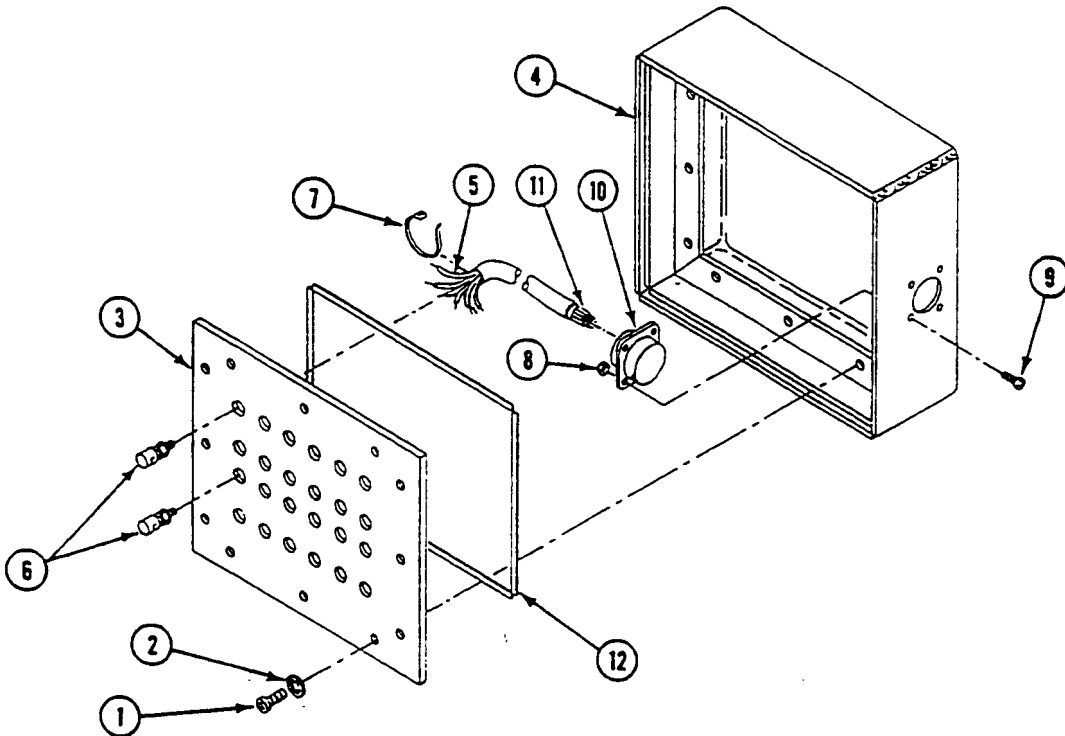

ASSEMBLY

1. If removed, install new gaskets (12) by applying a thin coat of adhesive to phone extension box surface and to gasket surface. Allow 10 to 20 minutes to dry (tacky to the touch). Position gasket on phone extension box and press firmly into place.

NOTE

Use wiring diagram page 0102 00-2 to identify location of post by color and for rewiring connector J1 and binding posts.

2. Install leads (11) in connector J1 (10).
3. Install connector J1 (10) on phone extension box (4). Secure with four screws (9) and new locknuts (8).
4. Install 24 binding posts (6) on faceplate (3).
5. Connect all leads (5) to 24 binding posts (6).
6. Install new straps (7), as required.
7. Install faceplate (3) on phone extension box (4). Secure with 12 new lockwashers (2) and screws (1).

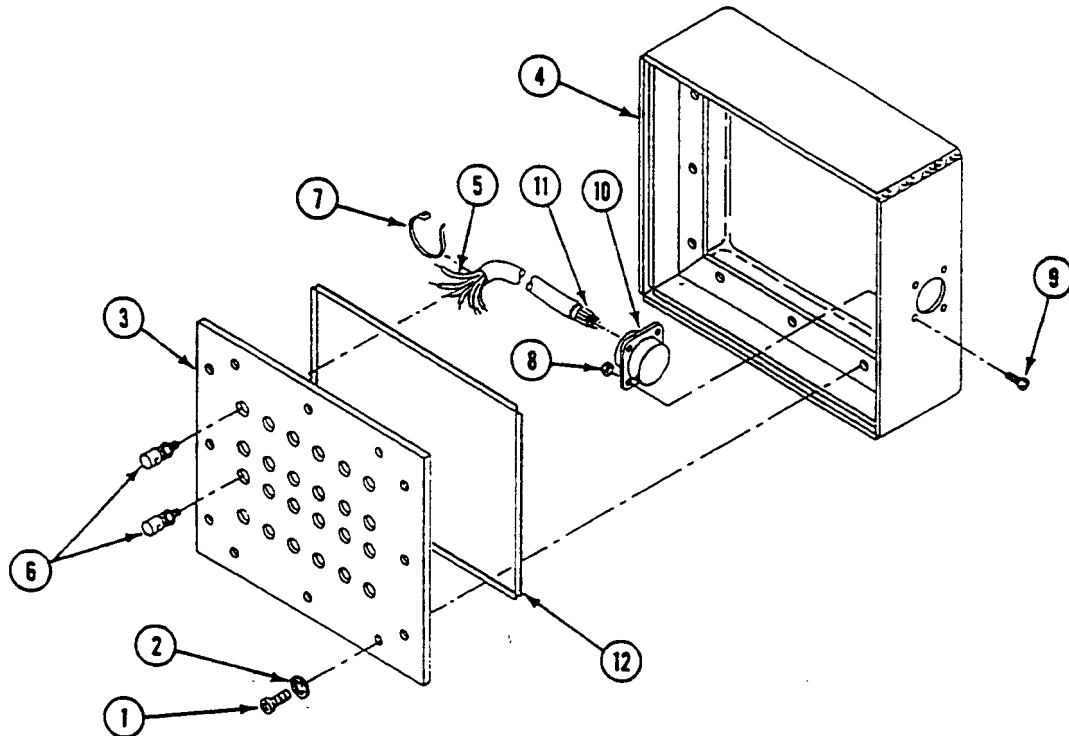
**FOLLOW-THROUGH STEPS**

1. Stow phone extension box in stowage box (see your -20).

END OF TASK

REPAIR ROADSIDE AC POWER EXTENSION BOX A18 (M1068A3 ONLY)

0103 00

THIS WORK PACKAGE COVERS:

Disassembly (page 0103 00-1).
 Assembly (page 0103 00-3).

INITIAL SETUP:

Maintenance Level

Direct Support

Personnel Required

Fuel and Elec Sys Rep 63G10

Tools and Special Tools

Automotive Fuel and Electrical System Repair Tool Kit
 (WP 0120 00, Item 59)

References

See your -20

Materials/Parts

Locknut (24)

Equipment Condition

Roadside AC power extension box A18 removed
 (see your -20)

DISASSEMBLY

NOTE

See wiring diagram page 0103 00-2 for assemble/disassemble of wires to connectors.

1. Remove four screws (1), cover (2) and gasket (3), from extension box (4).

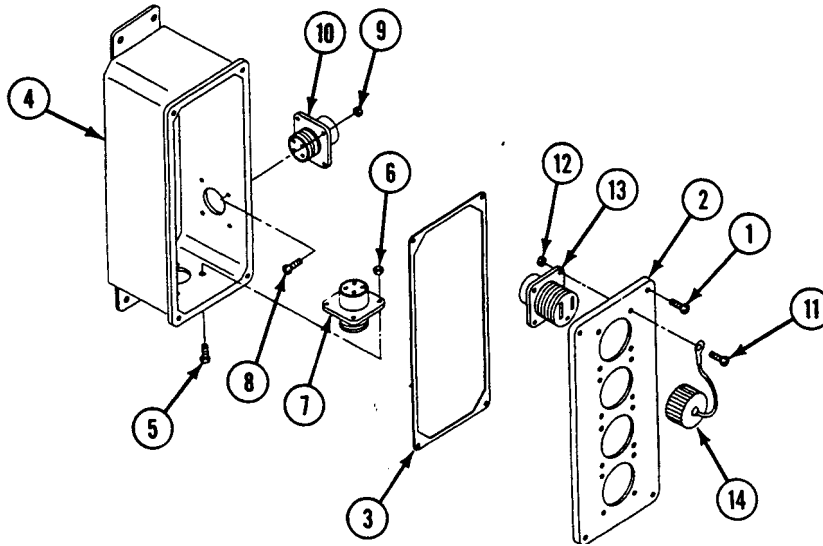

NOTE

Tag all leads before disconnecting for proper assembly later.

The four screws that secure connector J1 are shorter. Do not mix with other connectors.

2. Remove four screws (5), locknuts (6), and connector J6 (7) from extension box (4). Discard locknuts.
3. Remove four screws (8), locknuts (9), and connector J1 (10) from extension box (4). Discard locknuts.
4. Disconnect leads from connectors if necessary.

5. Remove 16 screws (11), locknuts (12), four connectors (13), and dust caps (14) from cover (2). Discard locknuts.

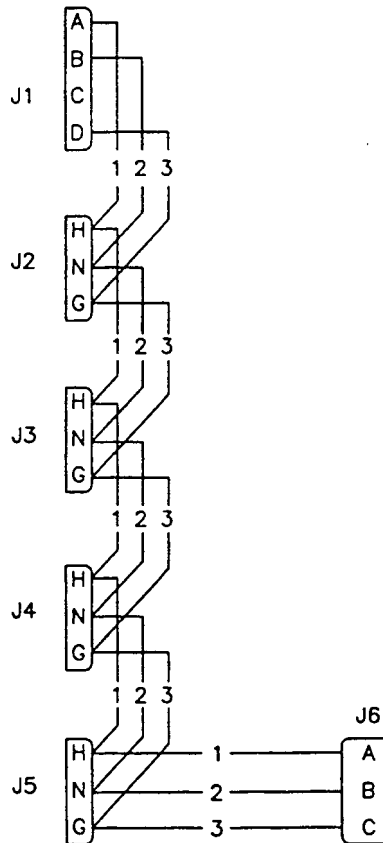
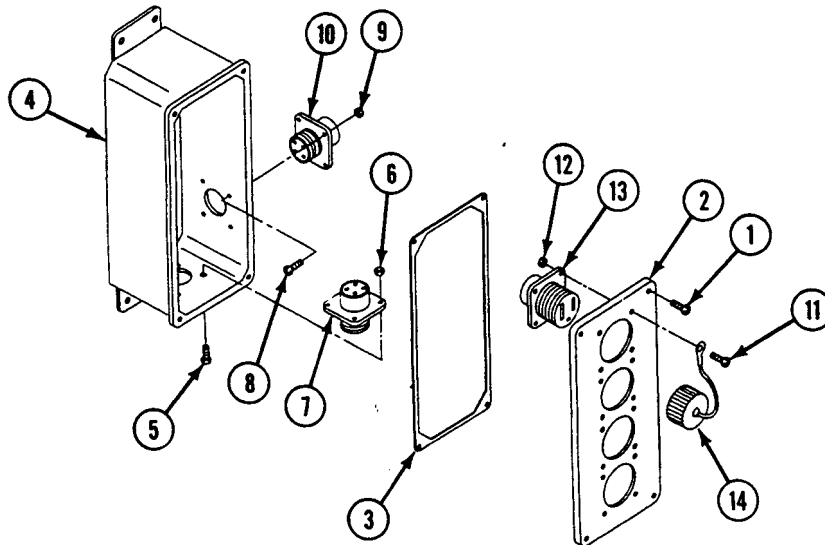

(A18) WIRING DIAGRAM

ASSEMBLY

NOTE

The four screws that secure connector J1 are shorter. Do not mix with other connectors.

1. Install four connectors (13) on cover (2) with dust caps (14) and secure with 16 screws (11) and new locknuts (12).
2. Install connector J1 (10) on extension box (4) and secure with four screws (8) and new locknuts (9).
3. Install connector J6 (7) on extension box (4) and secure with four screws (5) and new locknuts (6).

NOTE

See wiring diagram page 0103 00-2 for assembly/disassembly of wires to connectors.

4. Connect leads to connectors if necessary.
5. Install gasket (3) on extension box (4) with cover (2) and secure with four screws (1).

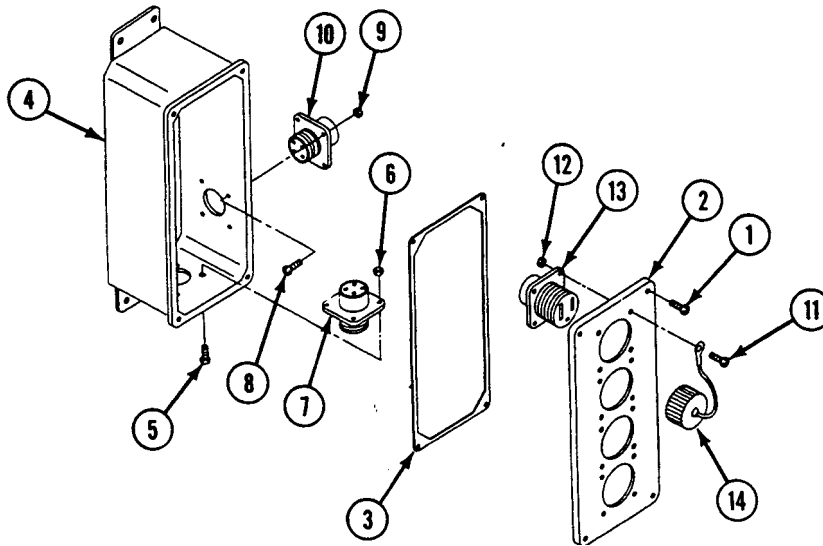

FOLLOW-THROUGH STEPS

1. Install roadside AC power extension box A18 (see your -20).

END OF TASK

REPAIR CURBSIDE AC POWER EXTENSION BOX A19 (M1068A3 ONLY)

0104 00

THIS WORK PACKAGE COVERS:

Disassembly (page 0104 00-1).
 Assembly (page 0104 00-4).

INITIAL SETUP:

Maintenance Level

Direct Support

Personnel Required

Fuel and Elec Sys Rep 63G10

Tools and Special Tools

Automotive Fuel and Electrical System Repair Tool Kit
 (WP 0120 00, Item 59)

References

See your -20

Materials/Parts

Locknut (28)

Equipment Condition

Curbside AC power extension box A19
 removed (see your -20)

DISASSEMBLY

NOTE

See wiring diagram page 0104 00-3 for assembly/disassembly of wires to connectors.

1. Remove four screws (1), cover (2), and gasket (3) from extension box (4).

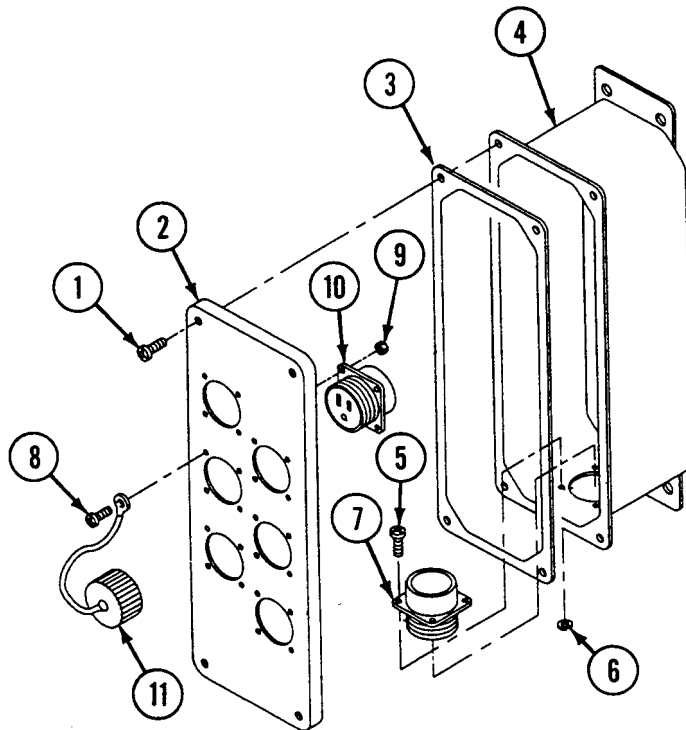

NOTE

Tag all leads before disconnecting for proper assembly later.

2. Remove four screws (5), locknuts (6), and connector J15 (7) from extension box (4). Discard locknuts.
3. Remove 24 screws (8), locknuts (9), six connectors (10), and dust caps (11) from cover (2). Discard locknuts.

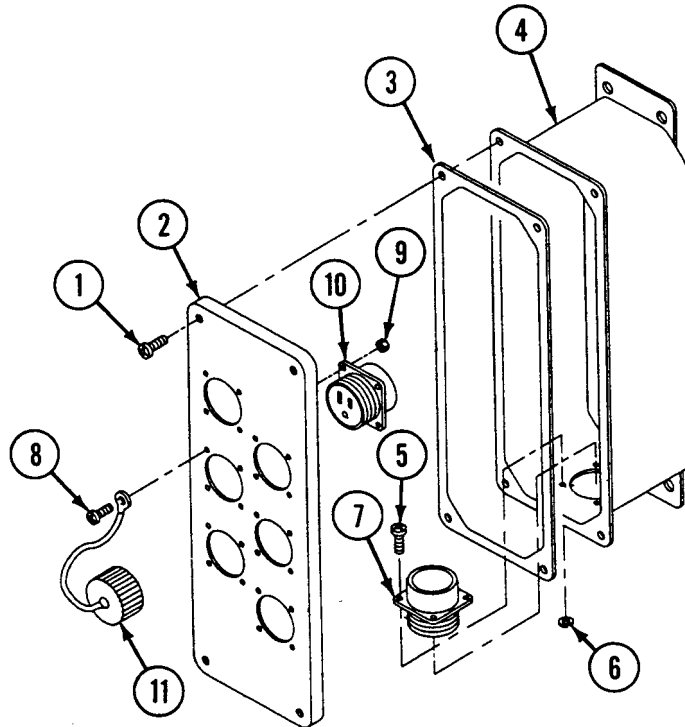

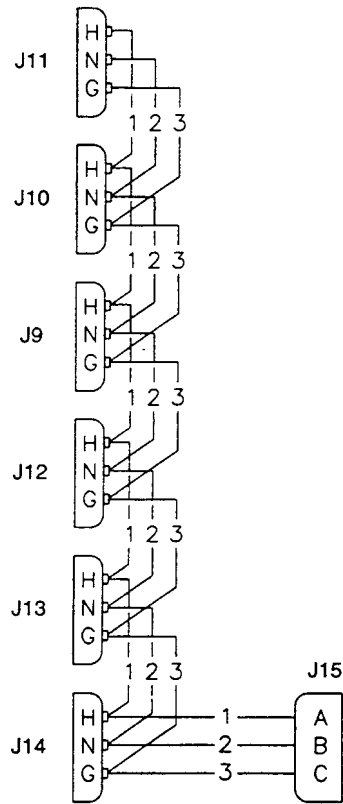

(A19) WIRING DIAGRAM

ASSEMBLY

1. Install six connectors (10) on cover (2) with dust caps (11) and secure with 24 screws (8) and new locknuts (9).
2. Install connector J15 (7) on extension box (4) and secure with four screws (5) and new locknuts (6).

NOTE

See wiring diagram page 0104 00-3 for assembly/disassembly of wires to connectors.

3. Connect leads to connectors if necessary.
4. Install gasket (3) on extension box (4) with cover (2) and secure with four screws (1).

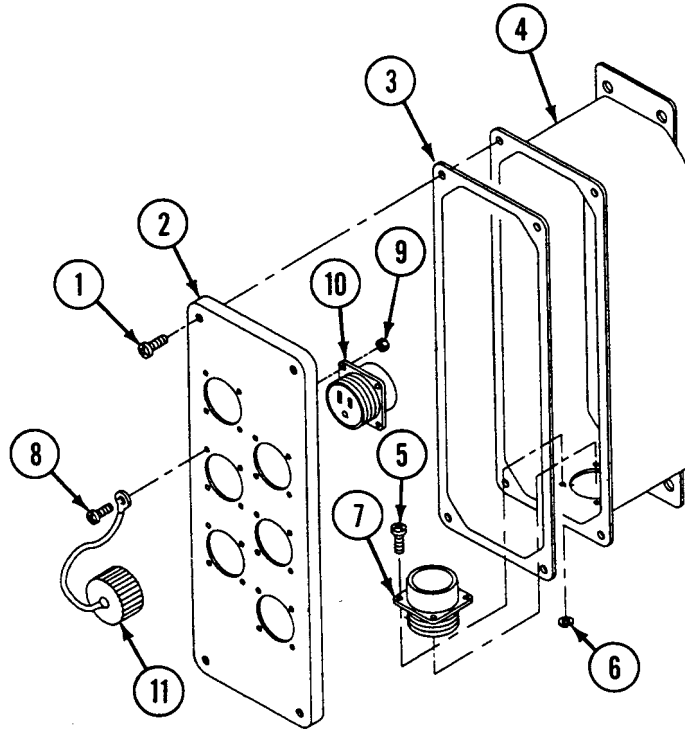
**FOLLOW-THROUGH STEPS**

1. Install curbside AC power extension box A19 (see your -20).

END OF TASK

REPLACE LAN A CABLE W101 AND/OR LAN B CABLE W102 (M1068A3 ONLY)

0105 00

THIS WORK PACKAGE COVERS:

Removal (page 0105 00-1).
 Installation (page 0105 00-3).

INITIAL SETUP:

Maintenance Level

Direct Support

Tools and Special Tools

Electronic Equipment Tool Kit (WP 0120 00, Item 61)

Materials/Parts

Locknut (2)
 Lock washer (14)
 Strap

Personnel Required

Radio Repairer 29E10
 Helper (H)

References

See your -10
 See your -20
 TM 11-7010-256-12&P

Equipment Condition

Engine stopped (see your -10)
 Carrier blocked (see your -10)
 All external power disconnected
 (TM 11-7010-256-12&P)
 Battery ground strap disconnected (see your -20)

REMOVAL

1. Lift and secure cover (1) of external communications box A11 (2).
2. Remove fourteen screws (3), Lock washers (4), and faceplate (5) from external communications box A11 (2). Discard Lock washers.

NOTE

Tag cables before disconnecting them.

3. Disconnect cable W101, jack J103 (6), jamnut (7), inside bushing (8) and outside bushing (9) from faceplate LAN A (10) on external communications box A11 (2).
4. Disconnect cable W102, jack J104 (11) jamnut (7), inside bushing (8) and outside bushing (9) from faceplate LAN B (12) on external communications box A11 (2).

REPLACE LAN A CABLE W101 AND/OR LAN B CABLE W102 (M1068A3 ONLY) —
Continued

0105 00

- Remove and push cable(s) W101 (6) and/or W102 (11) down into hull, pull through opening in bottom (13) of external communications box A11 (2). Have helper assist.

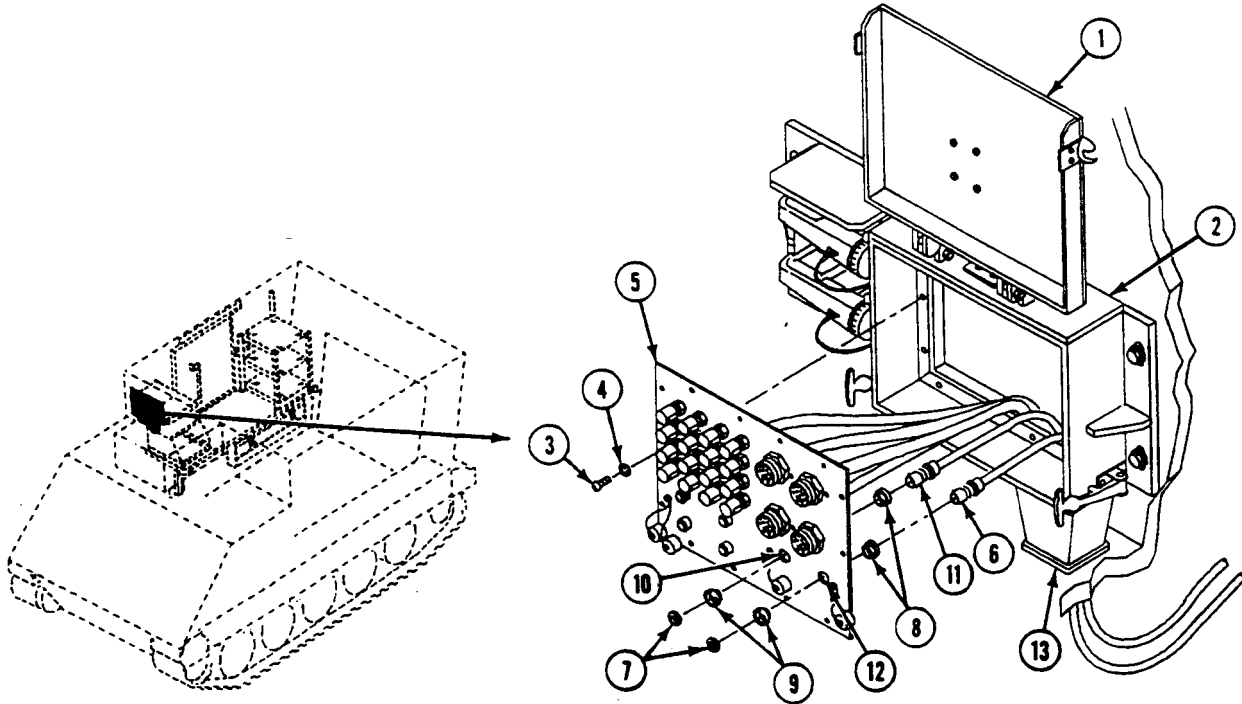

- Remove two locknuts (1), four washers (2), two screws (3), and clamps (4) from cables W101 (5) and W102 (6). Discard locknuts.
- Remove and discard straps (7) as required.

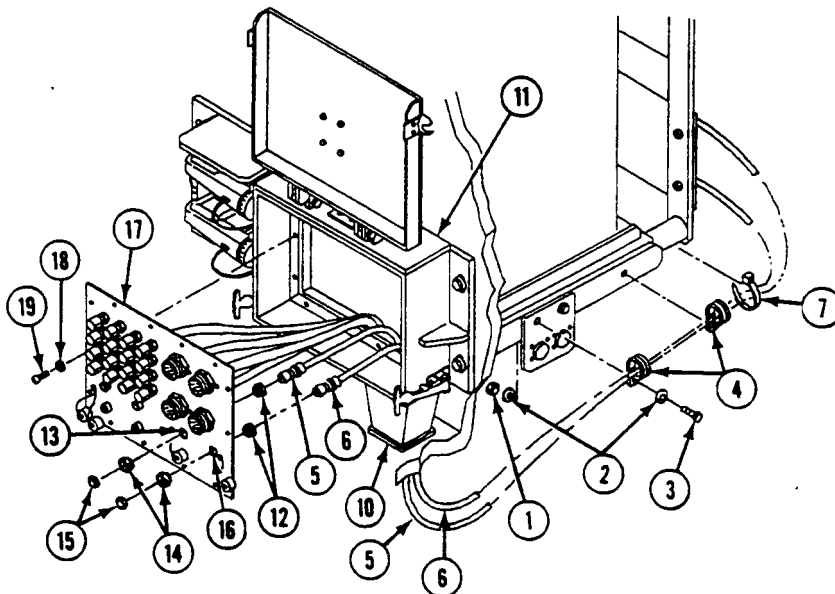

REPLACE LAN A CABLE W101 AND/OR LAN B CABLE W102 (M1068A3 ONLY) —
Continued

0105 00

8. Disconnect cable W101, (5) from data panel assembly A12, jack J1 (8), remove from vehicle.
9. Disconnect cable W102, (6) from data panel assembly A12, jack J4 (9), remove from vehicle.

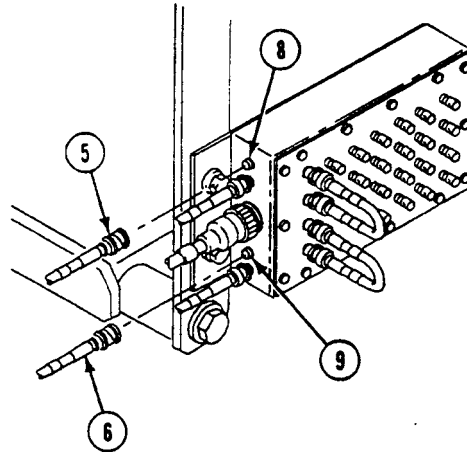

INSTALLATION

1. Install cable W101, jack J103 (5) and/or cable W102, jack J104 (6) in vehicle and route through hole in hull top plate (10) up into base of external communications box A11 (11). Have helper assist.

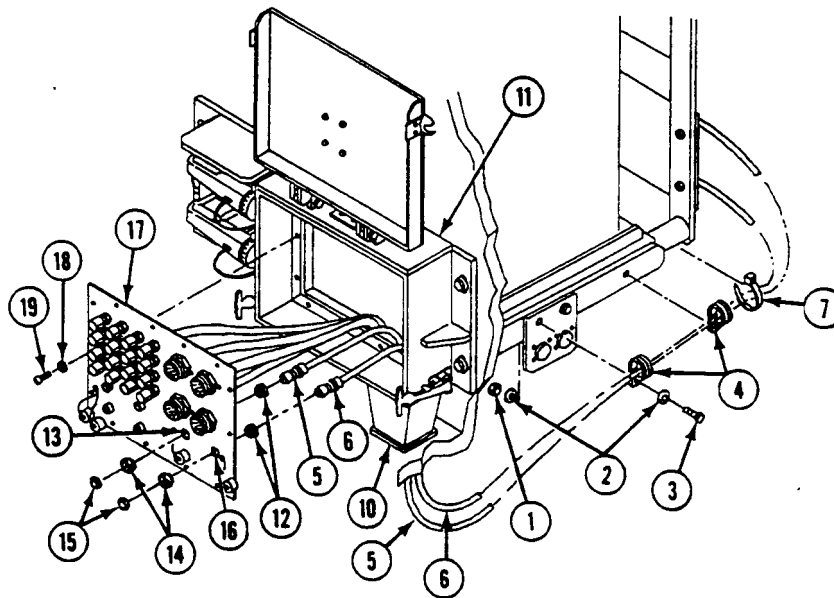

REPLACE LAN A CABLE W101 AND/OR LAN B CABLE W102 (M1068A3 ONLY) —
Continued

0105 00

2. Connect cable W101, (5) on data panel assembly A12, jack J1 (8).
3. Connect cable W102, (6) on data panel assembly A12, jack J4 (9).

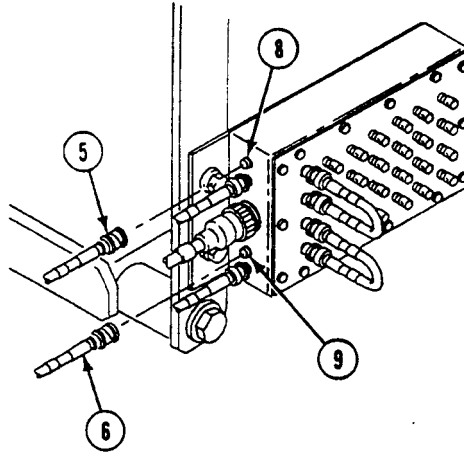

4. Connect cable W101, jack J103 (5) with inside bushing (12), on faceplate LAN A (13) secure with outside bushing (14) and jamnut (15).
5. Connect cable W102, jack J104 (6) with inside bushing (12), on faceplate LAN B (16) secure with outside bushing (14) and jamnut (15).
6. Secure cable W101 (5) and/or W102 (6) to hull with two clamps (4), screws (3), four washers (2), and two new locknuts (1).
7. Secure slack in cable with new straps (7) as required.
8. Install faceplate (17) on external communications box A11 (11), secure with fourteen new lock washers (18), and screws (19).

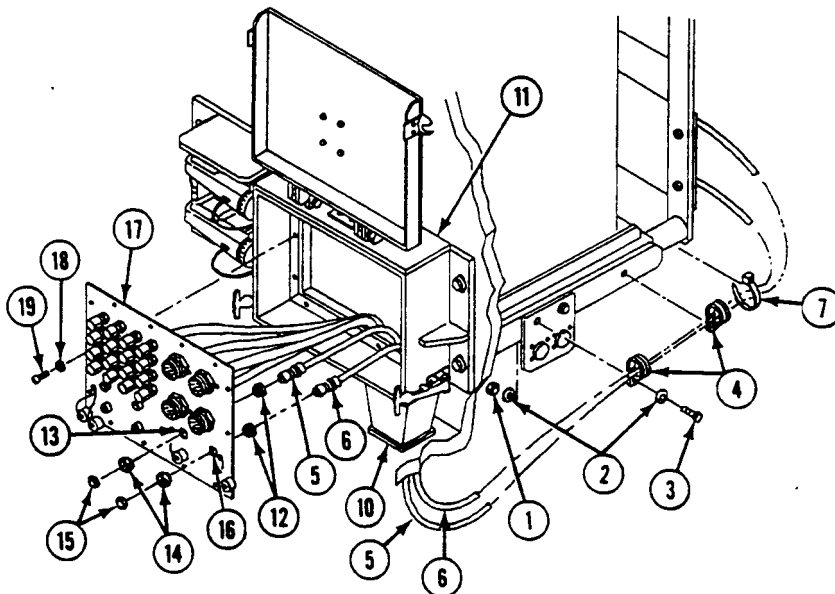

REPLACE LAN A CABLE W101 AND/OR LAN B CABLE W102 (M1068A3 ONLY) —
Continued

0105 00

FOLLOW-THROUGH STEPS

1. Connect battery ground strap (see your -20).
2. Turn MASTER SWITCH ON (see your -10). Check that electrical system works properly.
3. Turn MASTER SWITCH OFF (see your -10).

END OF TASK

**REPLACE RF 1, 2, 3, 4 CABLE ASSEMBLIES W111, W112, W113, AND
W114 (M1068A3 ONLY)**

0106 00

THIS WORK PACKAGE COVERS:

Removal (page 0106 00-2).
Installation (page 0106 00-5).

INITIAL SETUP:

Maintenance Level

Direct Support

Tools and Special Tools

Electronic Equipment Tool Kit (WP 0120 00, Item 61)

Materials/Parts

Lock washer (14)
Straps

Personnel Required

Radio Repairer 29E10
Helper (H)

References

See your -20

Equipment Condition

External communication box removed (see your -20)

REPLACE RF 1, 2, 3, 4 CABLE ASSEMBLIES W111, W112, W113, AND W114 (M1068A3 ONLY) — Continued

0106 00

REMOVAL

1. Lift and secure cover (1) of external communications box (2).

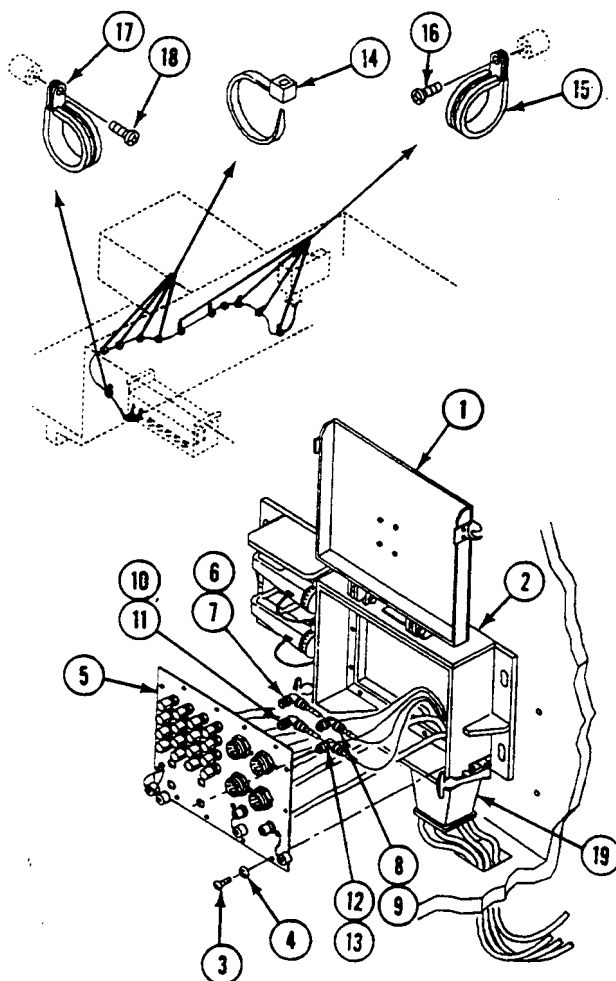

2. Remove 14 screws (3), lockwashers (4), and faceplate (5) from external communications box (2). Discard lockwashers.

NOTE

Tag all cables before disconnecting them.

3. Disconnect W111, plug P2 (6) from jack J115 (7) on faceplate (5).
4. Disconnect W112, plug P2 (8) from jack J116 (9) on faceplate (5).
5. Disconnect W113, plug P2 (10) from jack J117 (11) on faceplate (5).
6. Disconnect W114, plug P2 (12) from jack J118 (13) on faceplate (5).
7. Remove and discard straps (14) as required.
8. Remove five clamps (15) and screws (16).
9. Remove clamp (17) and screw (18).

REPLACE RF 1, 2, 3, 4 CABLE ASSEMBLIES W111, W112, W113, AND W114 (M1068A3 ONLY) — Continued

0106 00

10. Pull harness through base (19) of communications box (2). Have helper assist.

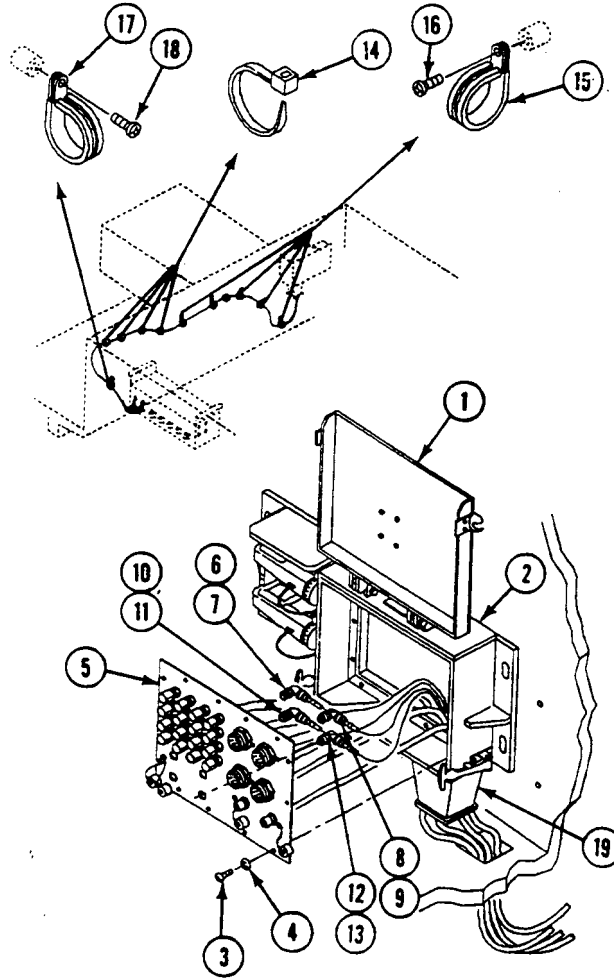

NOTE

Tag all cables before disconnecting them.

11. Disconnect W111, plug P1 (1) from jack J115 (2) on signal patch panel box (3).
12. Disconnect W112, plug P1 (4) from jack J116 (5) on signal patch panel box (3).
13. Disconnect W113, plug P1 (6) from jack J117 (7) on signal patch panel box (3).
14. Disconnect W114, plug P1 (8) from jack J118 (9) on signal patch panel box (3).
15. Remove cable assemblies from carrier. Have helper assist.

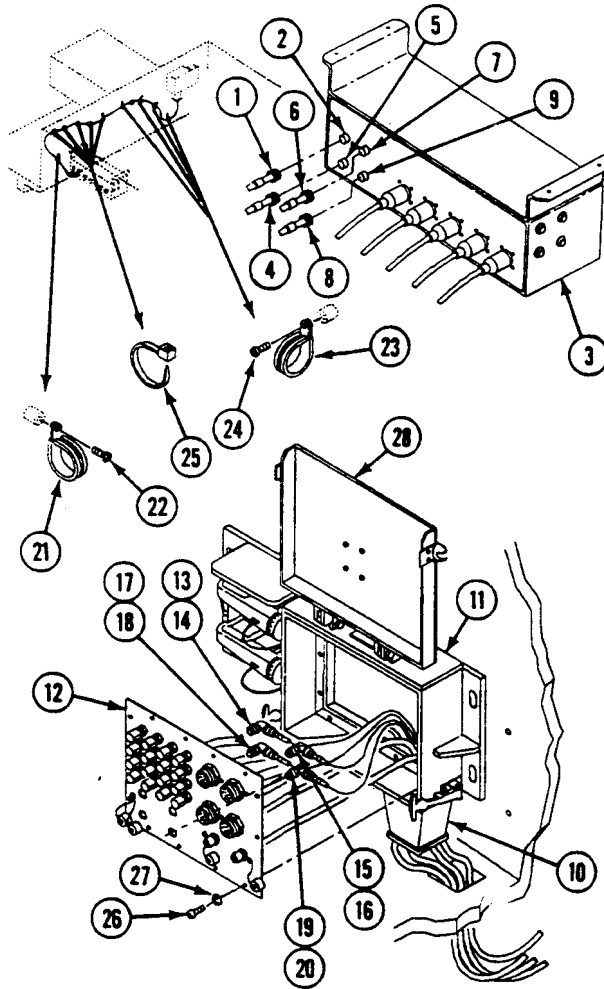

REPLACE RF 1, 2, 3, 4 CABLE ASSEMBLIES W111, W112, W113, AND W114 (M1068A3 ONLY) — Continued

INSTALLATION

1. Install cable assemblies in carrier. Have helper assist.
2. Push harness into base (10) of external communications box (11). Have helper assist.
3. Connect W111, plug P1 (1) to jack J115 (2) on signal patch panel box (3).
4. Connect W112, plug P1 (4) to jack J116 (5) on signal patch panel box (3).
5. Connect W113, plug P1 (6) to jack J117 (7) on signal patch panel box (3).
6. Connect W114, plug P1 (8) to jack J118 (9) on signal patch panel box (3).
7. Connect harness to inside of faceplate (12) of external communications box (11).
8. Connect W111, plug P2 (13) to jack J115 (14) on faceplate (12).
9. Connect W112, plug P2 (15) to jack J116 (16) on faceplate (12).
10. Connect W113, plug P2 (17) to jack J117 (18) on faceplate (12).

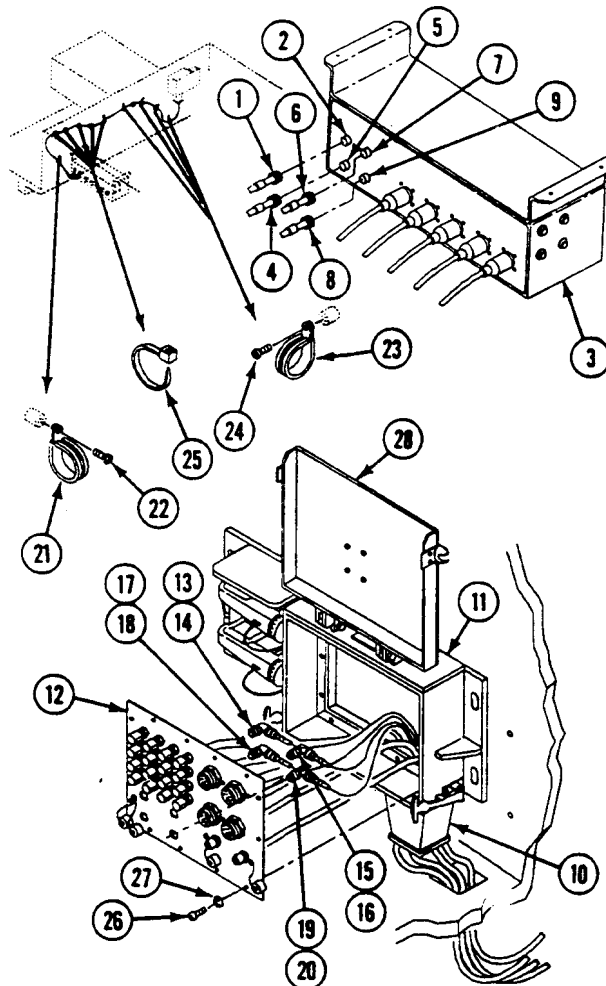

REPLACE RF 1, 2, 3, 4 CABLE ASSEMBLIES W111, W112, W113, AND W114 (M1068A3 ONLY) — Continued

0106 00

11. Connect W114, plug P2 (19) to jack J118 (20) on faceplate (12).
12. Install clamp (21) and screw (22).
13. Install five clamps (23) and screws (24).
14. Install new straps (25) as required.
15. Install faceplate (12) on external communications box (11), secure with 14 screws (26) and new lockwashers (27).
16. Lower and secure cover (28) of external communications box (11).

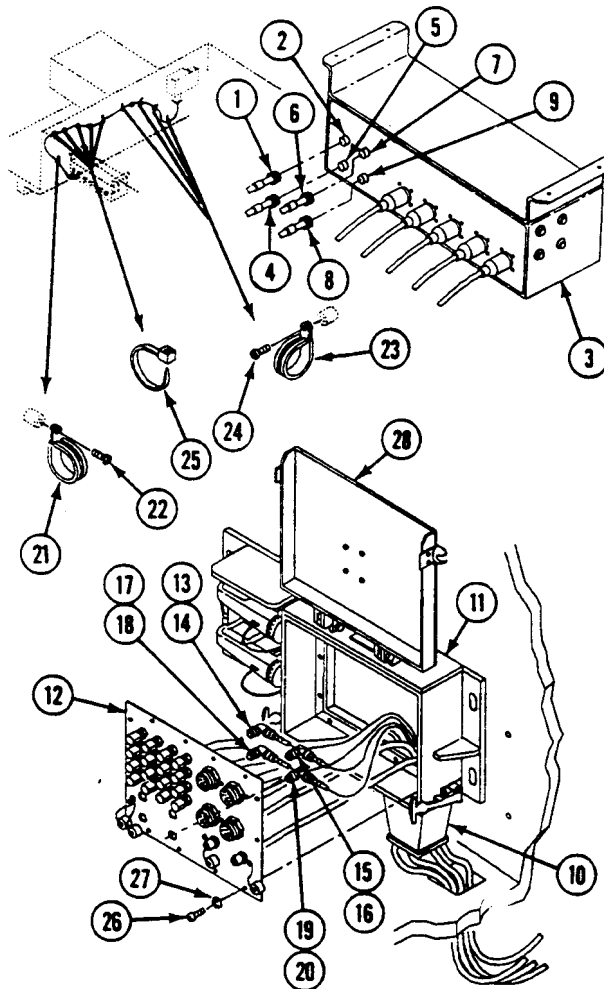
**FOLLOW-THROUGH STEPS**

1. Install external communication box (see your -20).

END OF TASK

REPLACE CABLE ASSEMBLY W115 (M1068A3 ONLY)

0107 00

THIS WORK PACKAGE COVERS:

Removal (page 0107 00-1).
 Installation (page 0107 00-3).

INITIAL SETUP:

Maintenance Level

Direct Support

Personnel Required

Radio Repairer 29E10
 Helper (H)

Tools and Special Tools

Electronic Equipment Tool Kit (WP 0120 00, Item 61)

References

See your -20

Materials/Parts

Lockwasher (14)
 Strap

Equipment Condition

External communication box removed (see your -20)

REMOVAL

1. Open and secure lid (1) on external communication box (2).
2. Remove 14 screws (3), lockwashers (4), and faceplate (5) from external communication box (2). Discard lockwashers.

NOTE

Tag leads before disconnecting from binding posts.

3. Remove binding posts (6) and 16 leads (7) from external communication box (2).
4. Remove screws (8) and clamps (9) from weldnuts (10), as required.
5. Remove and discard straps (11), as required.
6. Disconnect cable assembly W115, plug P106 (12) from jack J136 (13) on signal patch panel box (14).

7. Pull cable assembly W115 down through base (15) out of external communications box (2). Remove cable assembly W115 from vehicle. Have helper assist.

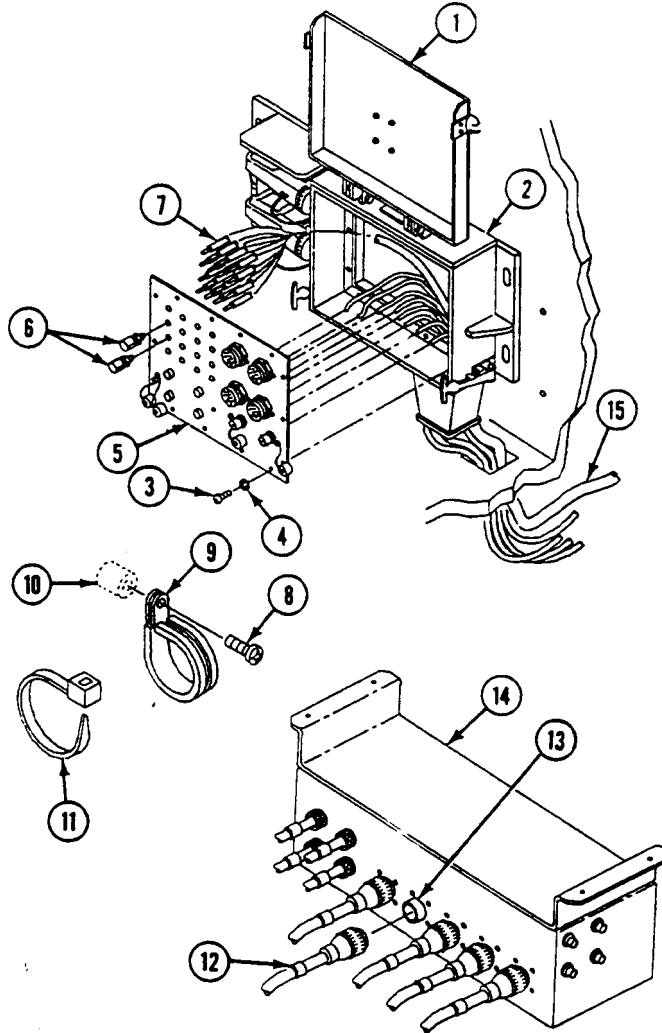

INSTALLATION

1. Install cable assembly W115 into vehicle, and route cable up through base (15) into external communications box (2). Have helper assist.
2. Connect cable assembly W115, plug P106 (12) to jack J136 (13) on signal patch panel box (14).
3. Install clamps (9) on cable assembly and secure to weldnuts (10) with screws (8), as required.
4. Install new straps (11) to secure cable W115, as required.
5. Connect 16 leads (7) to binding post (6) on faceplate (5).
6. Install faceplate (5) on external communication box (2) and secure with 14 new lockwashers (4) and screws (3).
7. Close and secure lid (1) on external communication box (2).

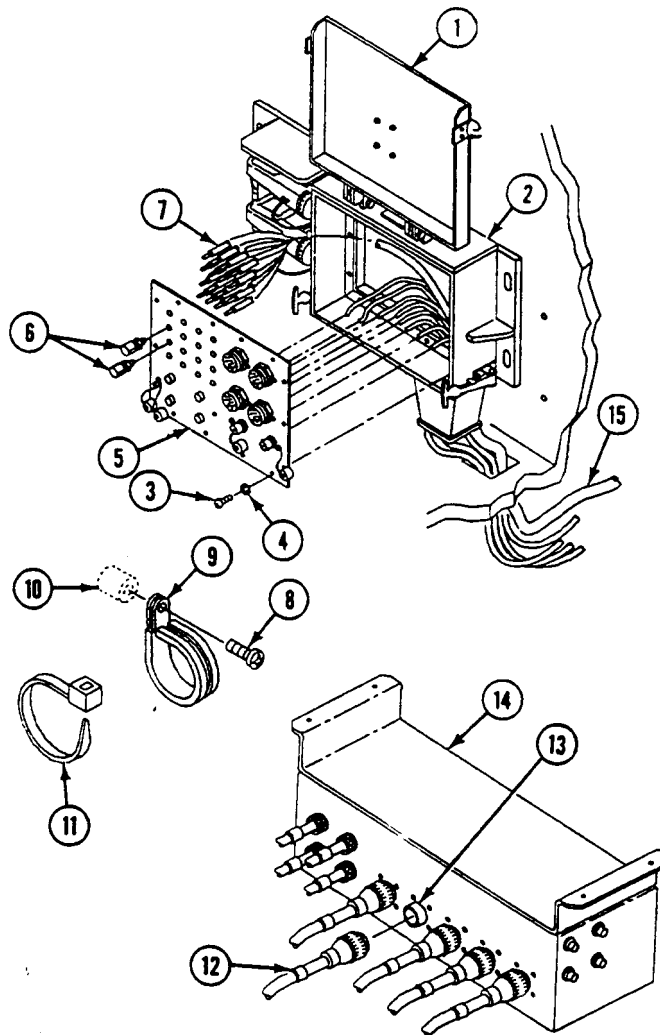

FOLLOW-THROUGH STEPS

1. Install external communication box (see your -20)

END OF TASK

REPLACE CABLE ASSEMBLIES W117 AND W118 (M1068A3 ONLY)

0108 00

THIS WORK PACKAGE COVERS:

Removal (page 0108 00-1).
 Installation (page 0108 00-3).

INITIAL SETUP:

Maintenance Level

Direct Support

Personnel Required

Radio Repairer 29E10
 Helper (H)

Tools and Special Tools

Electronic Equipment Tool Kit (WP 0120 00, Item 61)

References

See your -20

Materials/Parts

Lockwasher (12)
 Strap

Equipment Condition

External communication box removed (see your -20)

REMOVAL

NOTE

Tag all cables before disconnecting them.

1. Remove 12 screws (1), lock washers (2), and connectors J101 (3) and J102 (4) from the external communication box (5). Discard lockwashers.
2. Remove cable assemblies W117 (6) from connector J101 (3).
3. Remove cable W117 (6) and W118 (7) from connector J102 (4) of external communication box (5).
4. Remove screws (8) and clamps (9) from weldnuts (10), as required.
5. Remove and discard straps (11), as required.
6. Disconnect cable assembly W118, plug P105 (12) from jack J135 (13) on signal patch panel box (14).

7. Pull cable assembly W118 down through base (15) out of external communications box (5). Remove cable assembly W118 from vehicle. Have helper assist.

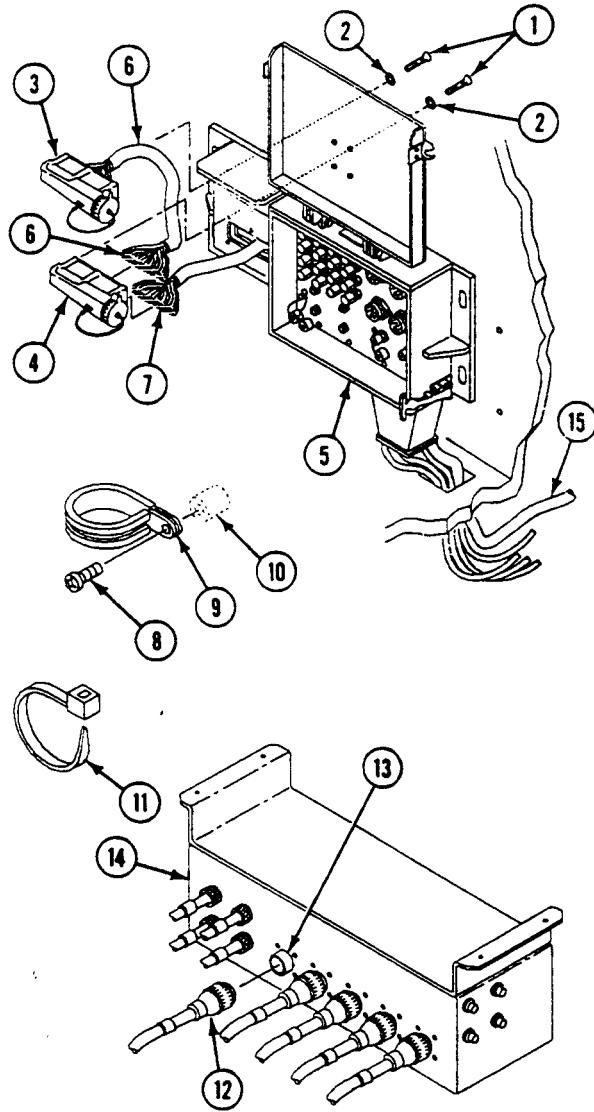

INSTALLATION

1. Install cable assembly W118 into vehicle, and route cable up through base (15) into external communications box (5). Have helper assist.
2. Connect cable assembly W118, plug P105 (12) to jack J135 (13) on signal patch panel box (14).
3. Install clamps (9) on cable assembly and secure to weldnuts (10) with screws (8), as required.
4. Install new straps (11) to secure cable assembly, as required.
5. Install cable W117 (6) and W118 (7) on connector J102 (4) of external communication box (5).
6. Install cable assembly W117 (6) on connector J101 (3).
7. Install connectors J101 (3) and J102 (4) on the external communication box (5), secure with 12 screws (1), and new lockwashers (2).

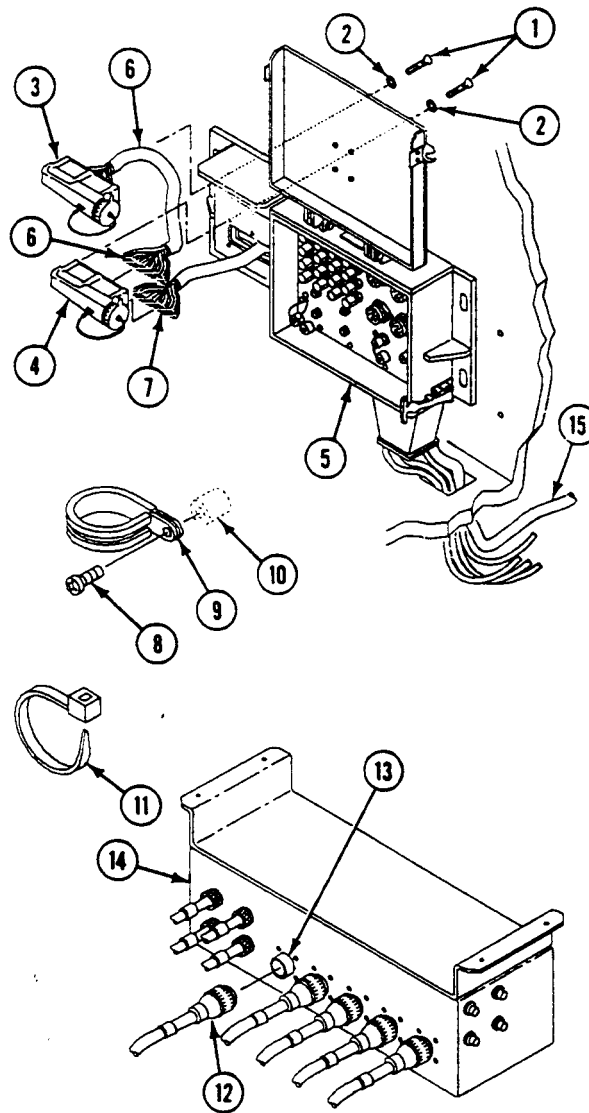

FOLLOW-THROUGH STEPS

1. Install external communication box (see your -20).

END OF TASK

CHAPTER 19

DIRECT SUPPORT MAINTENANCE INSTRUCTIONS
FOR PRECISION INSTRUMENTS AND SYSTEMS

WORK PACKAGE INDEX

<u>Title</u>	<u>Sequence No.</u>
REPAIR STE/ICE DISTRIBUTION BOX.....	0109 00
REPAIR STE/ICE WIRING HARNESS.....	0110 00

REPAIR STE/ICE DISTRIBUTION BOX

0109 00

THIS WORK PACKAGE COVERS:

Removal (page 0109 00-1).
 Installation (page 0109 00-4).

INITIAL SETUP:

Maintenance Level

Direct Support

Lockwasher (4)

Locknut

Locknut (8)

Tools and Special Tools

Automotive Fuel and Electrical System Repair Tool Kit

(WP 0120 00, Item 59)

General Mechanic's Tool Kit (WP 0120 00, Item 62)

Personnel Required

Fuel and Elec Sys Rep 63G10

References

See your -20

Materials/Parts

Adhesive (WP 0122 00, Item 1)

Equipment Condition

STE/ICE distribution box removed (see your -20)

REMOVAL

NOTE

Replace gasket if material is torn or cold flawed.

1. Remove ten screws (1), washers (2), and cover (3) from gasket (4).
2. Remove screw (5) from locknut (6). Disconnect chain (7) and discard locknut.
3. Unscrew and remove cap (8) from connector J2 (9).

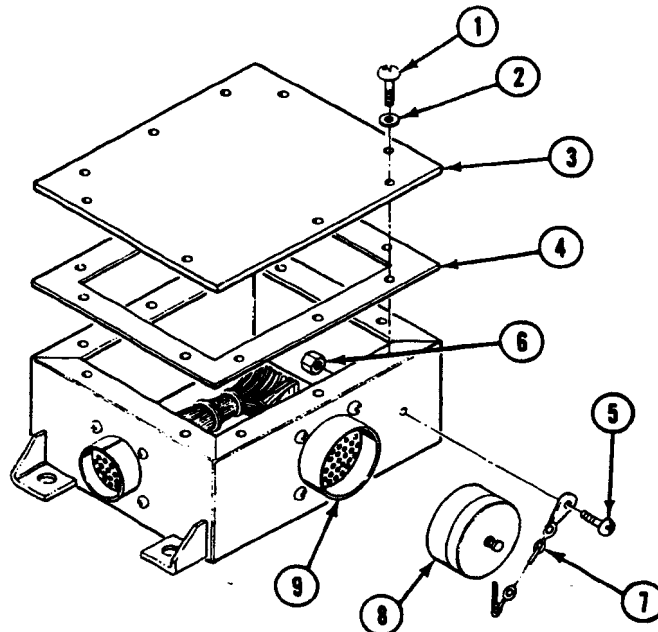

4. Remove four screws (10), washers (11), locknuts (12), and connector J1 (13). Discard locknuts.
5. Remove gasket (14) and inspect for torn or cold flawed areas. Replace if necessary.
6. Remove four screws (15), washers (16), and four locknuts (17). Discard locknuts and remove connector J2 (18).
7. Remove gasket (19) and inspect for torn or cold flawed areas. Replace if necessary.

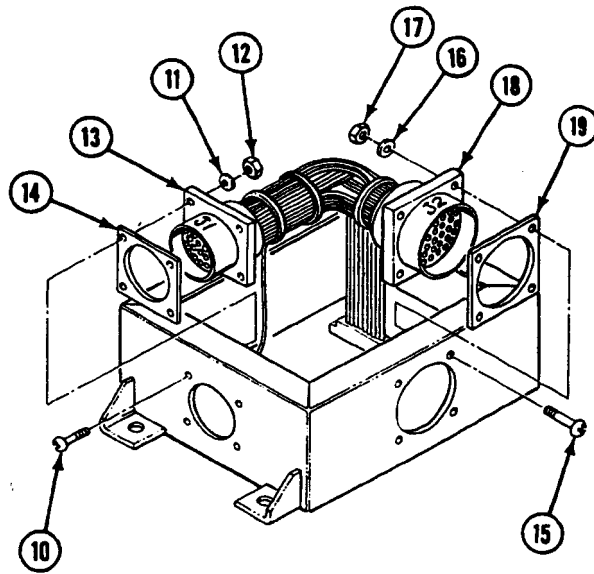

8. Remove screw (1), washer (2), lockwasher (3), and lead (4). Discard lockwasher.
9. Remove two screws (5), unplug connector (6), and remove wiring harness (7) from junction box (8).
10. Remove three remaining screws (1), washers (2), and lockwashers (3). Discard lockwashers.
11. Remove circuit card assembly (9) from junction box (8).

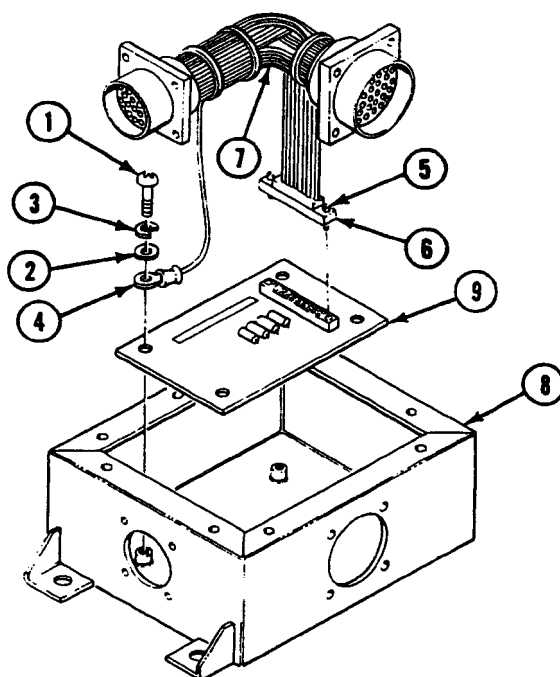

INSTALLATION

1. Position circuit card assembly (9) in junction box (8).
2. Install three washers (2), new lockwashers (3), and screws (1).
3. Position wiring harness (7) in junction box (8).
4. Install plug (6) to circuit card (9) and secure with two screws (5).
5. Connect lead (4), secure with screw (1), washer (2), and new lockwasher (3).

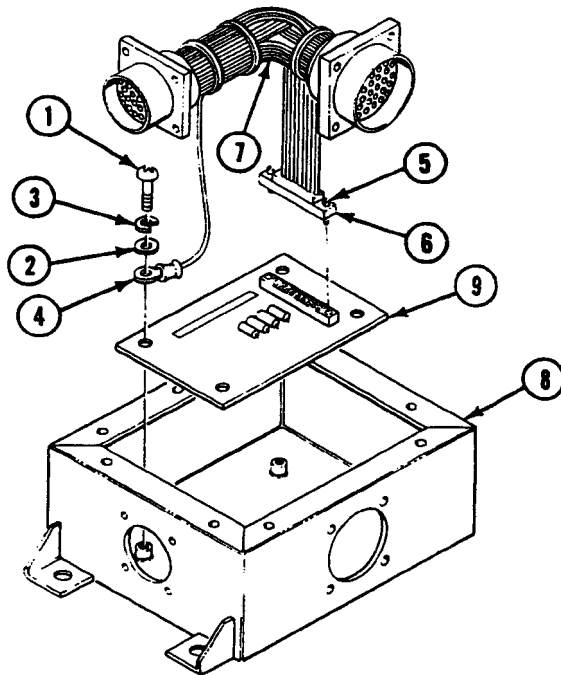

6. Install gasket (10) between connector J2 (11) and junction box (8).
7. Secure connector J2 (11) with four screws (12), washers (13), and four new locknuts (14).
8. Install gasket (15) between connector J1 (16) and junction box (8).
9. Secure connector J1 (16) with four screws (17), washers (18), and new locknuts (19).

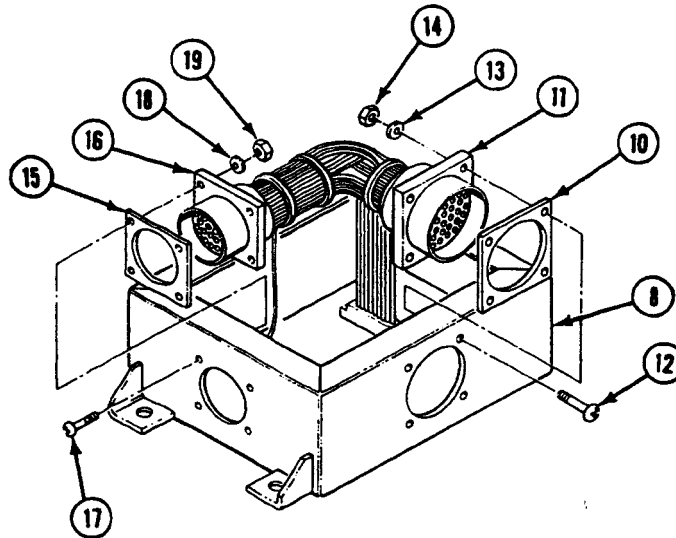

10. Install cap (8) on connector J2 (9).
11. Secure chain (7) with screw (5) and new locknut (6).
12. If required, cement gasket (4) to junction box. Apply a thin even coat of adhesive to both surfaces. Allow to dry until tacky. Press surfaces together firmly.
13. Position cover (3) on gasket (4) and secure with ten washers (2) and screws (1).

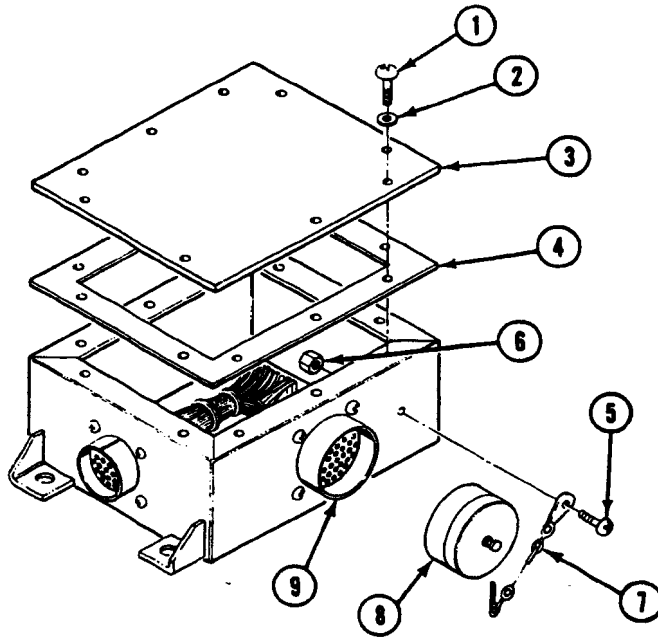

FOLLOW-THROUGH STEPS

1. Install STE/ICE distribution box (see your -20).

END OF TASK

REPAIR STE/ICE WIRING HARNESS

0110 00

THIS WORK PACKAGE COVERS:

Repair or Replacement (page 0110 00-1).

INITIAL SETUP:

Maintenance Level

Direct Support

Tools and Special Tools

- Automotive Fuel and Electrical System Repair Tool Kit (WP 0120 00, Item 59)
- Electrical Connector Tool Kit (WP 0120 00, Item 60)
- Digital Multimeter (WP 0120 00, Item 38)

Materials/Parts

Insulation tape (WP 0122 00, Item 19)

Personnel Required

Fuel and Elec Sys Rep 63G10

References

See your -20

Equipment Condition

Wiring harness removed (see your -20)

REPAIR OR REPLACEMENT

1. Perform continuity check on STE/ICE wiring harness to determine which parts require repair or replacement. Use multimeter.
2. Repair connector as required (WP 0026 00).
3. Repair terminals as required (see your -20).
4. Repeat continuity check on STE/ICE wiring harness assembly to determine that repairs have been completed.
5. Use insulation tape to bind wiring harness.

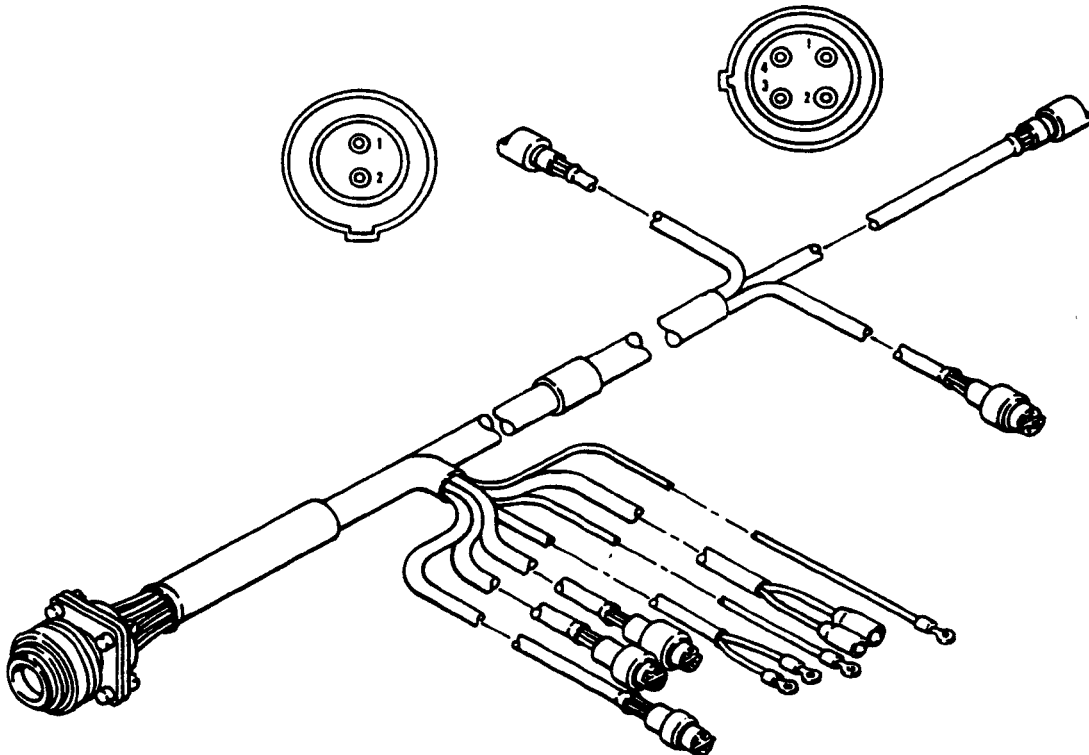

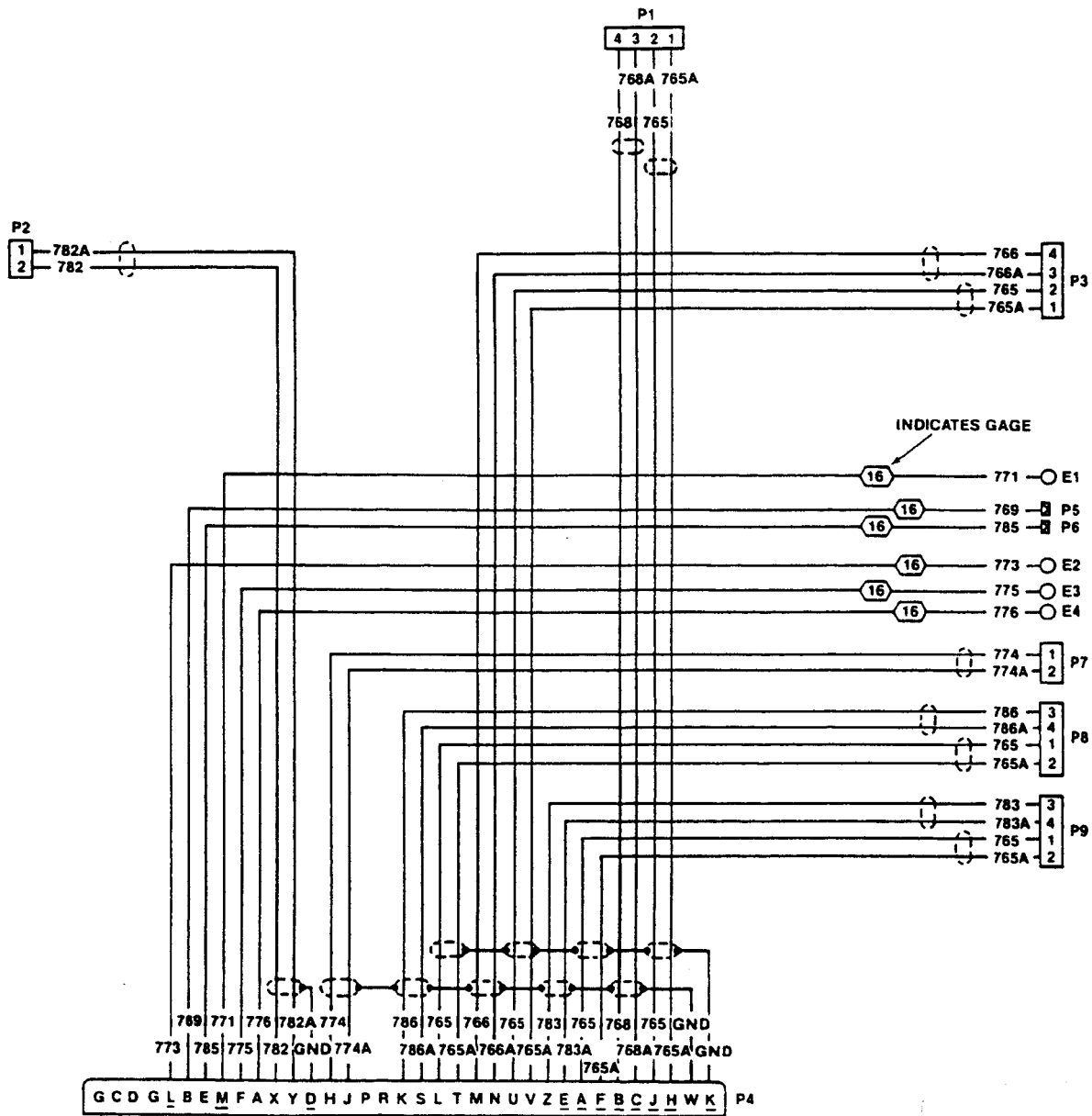

WIRING DIAGRAM (5)

FOLLOW-THROUGH STEPS

1. Install STE/ICE wiring harness (see your -20).

END OF TASK

CHAPTER 20

DIRECT SUPPORT MAINTENANCE INSTRUCTIONS
FOR FIRE FIGHTING EQUIPMENT

WORK PACKAGE INDEX

<u>Title</u>	<u>Sequence No.</u>
SERVICE CHEMICAL FIRE EXTINGUISHER (M1059A3 ONLY).....	0111 00
SERVICE FIRE EXTINGUISHER CYLINDER AND SAFETY DISC.....	0112 00

SERVICE CHEMICAL FIRE EXTINGUISHER (M1059A3 ONLY)

0111 00

THIS WORK PACKAGE COVERS:

 Servicing (page 0111 00-1).

INITIAL SETUP:

Maintenance Level

 Direct Support

Personnel Required

 Track Vehicle Repairer 63H10

Tools and Special Tools

 General Mechanic's Tool Kit (WP 0120 00, Item 62)
 Mail and Parcel Post Scale (WP 0120 00, Item 48)

References

 See your -20

Materials/Parts

 Automotive grease (WP 0122 00, Item 6)
 Wiping rag (WP 0122 00, Item 36)

Equipment Condition

 Fire extinguisher removed from carrier (see your -20)

SERVICING

INSPECTION AND MAINTENANCE

WARNING



Mechanical damage, evidence of welding or corrosion constitute a potential personnel hazard. Use extreme caution when handling fire extinguishers in this condition. Replace if necessary.

1. Invert extinguisher (1) and open nozzle (2) to release any remaining pressure or dust from cartridge receiver (3) and hose (4).
2. Return extinguisher (1) to upright position.
3. Inspect visual inspection seal wire (5) for security.
4. Examine outer components for cleanliness and corrosion or damage.
5. Check exterior shell (6), cartridge guard (7), cartridge receiver (3), hose (4), nozzle (2), and hand assembly (8) for wear or other disorders.

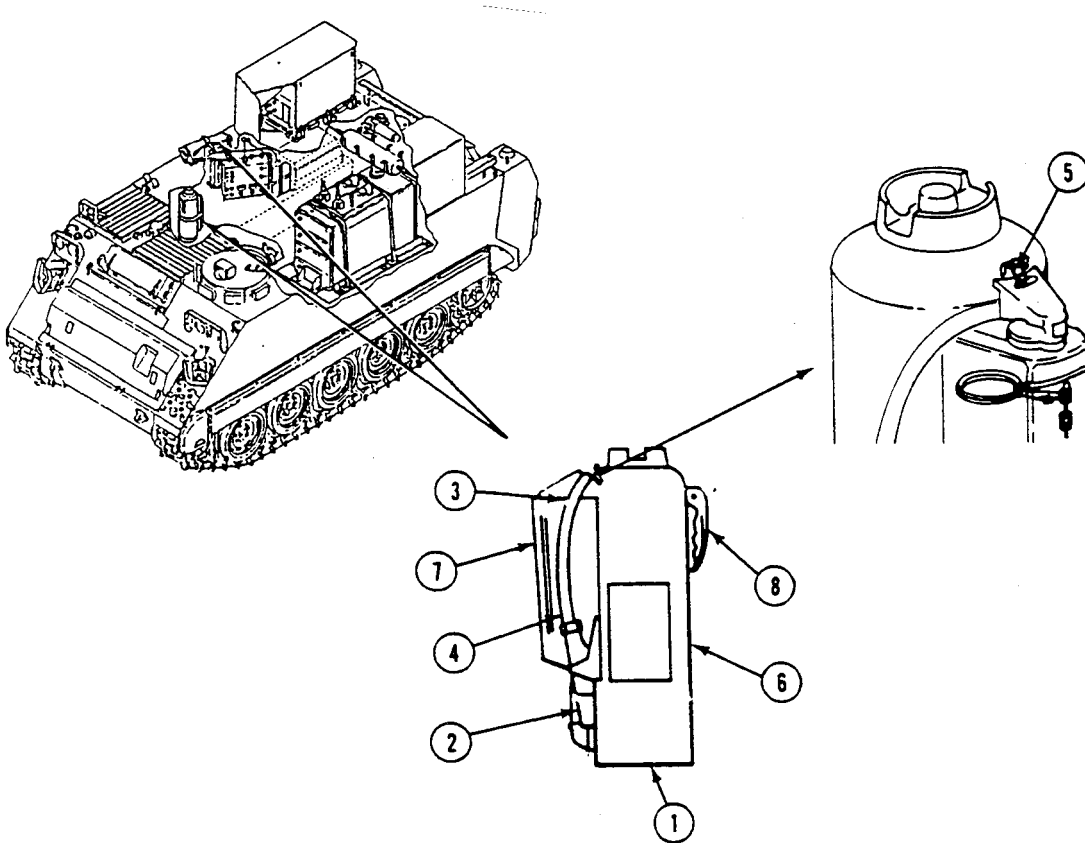

6. Check nameplates (1) for legibility and security. If nameplate is loose, remove and examine mounting area on shell (2) for corrosion.
7. Pull cartridge guard (3) from extinguisher (4). Inspect the inside components for working order and cleanliness.
8. Unscrew cartridge (5) left hand thread (counterclockwise). Check seal (6) for punctures.

WARNING

A cartridge can be punctured if the lever does not work freely. Do not install the cartridge before you make sure the puncture lever works freely.

9. Weigh cartridge (5). If weight is less than 1/2 oz. of weight stamped on cartridge, the cartridge must be replaced. Use 5-pound mail and parcel post scale.

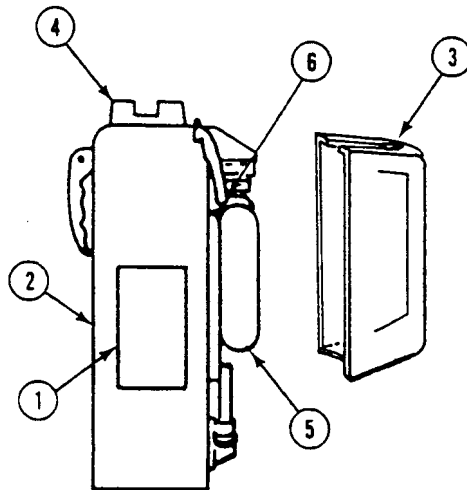

10. Remove nozzle (7) from holder (8) and lift hose (9) from behind puncture lever (10).
11. Operate puncture lever (10) to check for proper working order.
12. Check the pressure relief vent (11) for obstructions.
13. Remove cartridge receiver gasket (12) and check for cuts or wear. If damaged, replace.

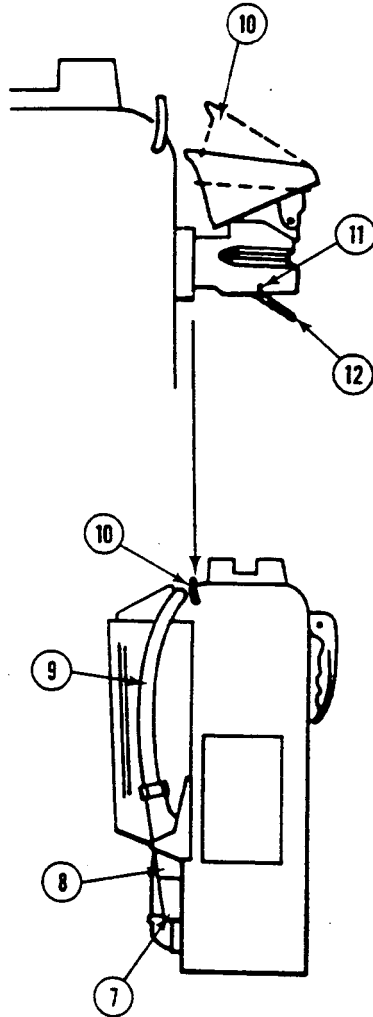

14. Examine hose (1) and hose couplings (2) for cuts or cracks.
15. Check nozzle (3) for proper operation.
 - a. Check handle (4) for binding.
 - b. Unscrew nozzle tip (5) and inspect for obstructions or damaged gasket (6).
 - c. Inspect plunger tip (7) for cuts or brittleness.
16. Check hose (1) for blockage.
 - a. Place extinguisher (8) horizontally on solid surface and discharge outlet UP.
 - b. Loosen filler cap (9) three and one half turns.
 - c. Wipe nozzle (3) clean and blow into extinguisher (8), observing gas escape from filler cap (9).
 - d. Unscrew hose (1) from extinguisher (8) and check preformed packing (10) for damage. If damaged, replace.

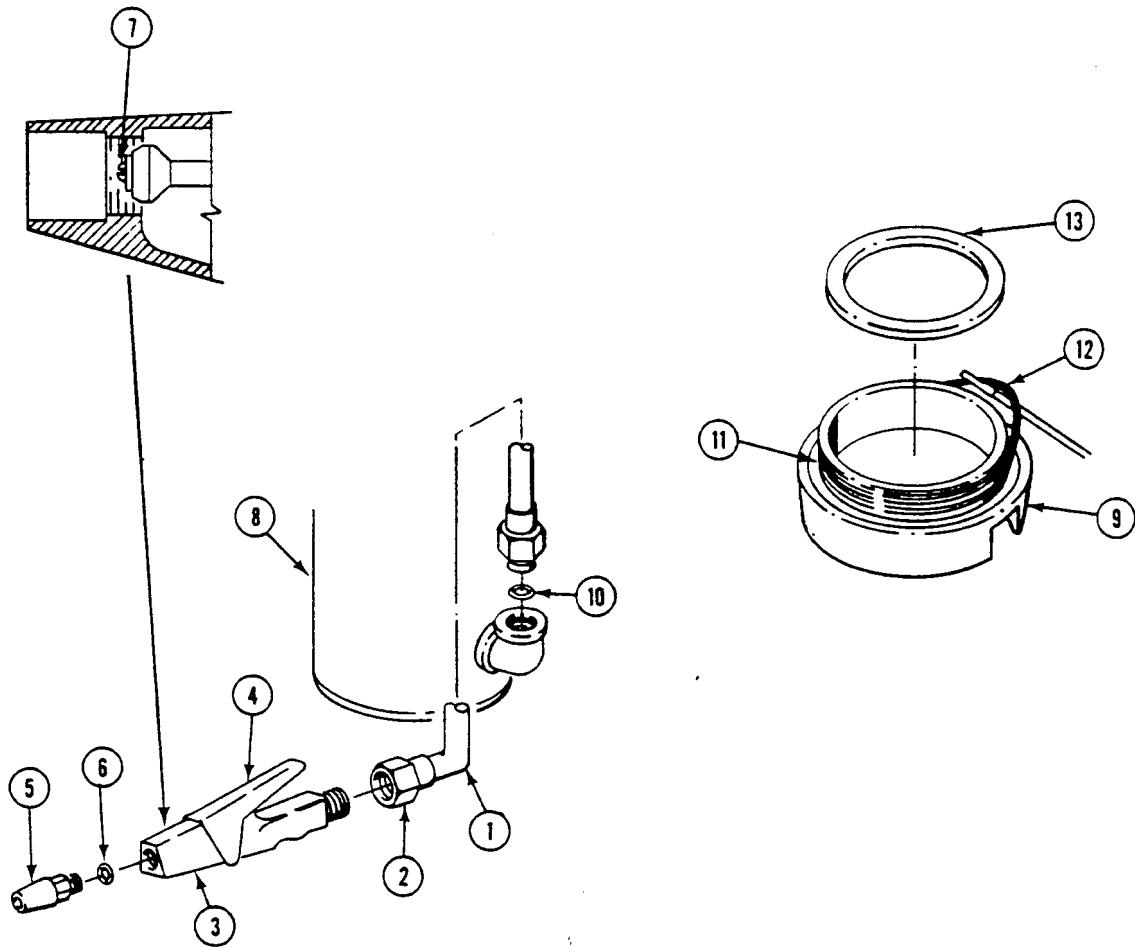

17. Return extinguisher (8) to upright position and remove filler cap (9). Remove any remaining dust.
18. Inspect filler cap (9) threads for nicks, cross threading, corrosion, and wear.
19. Check pressure relief vent (11) for obstructions.
20. Remove quad ring (12) and flat gasket (13) from filler cap (9).

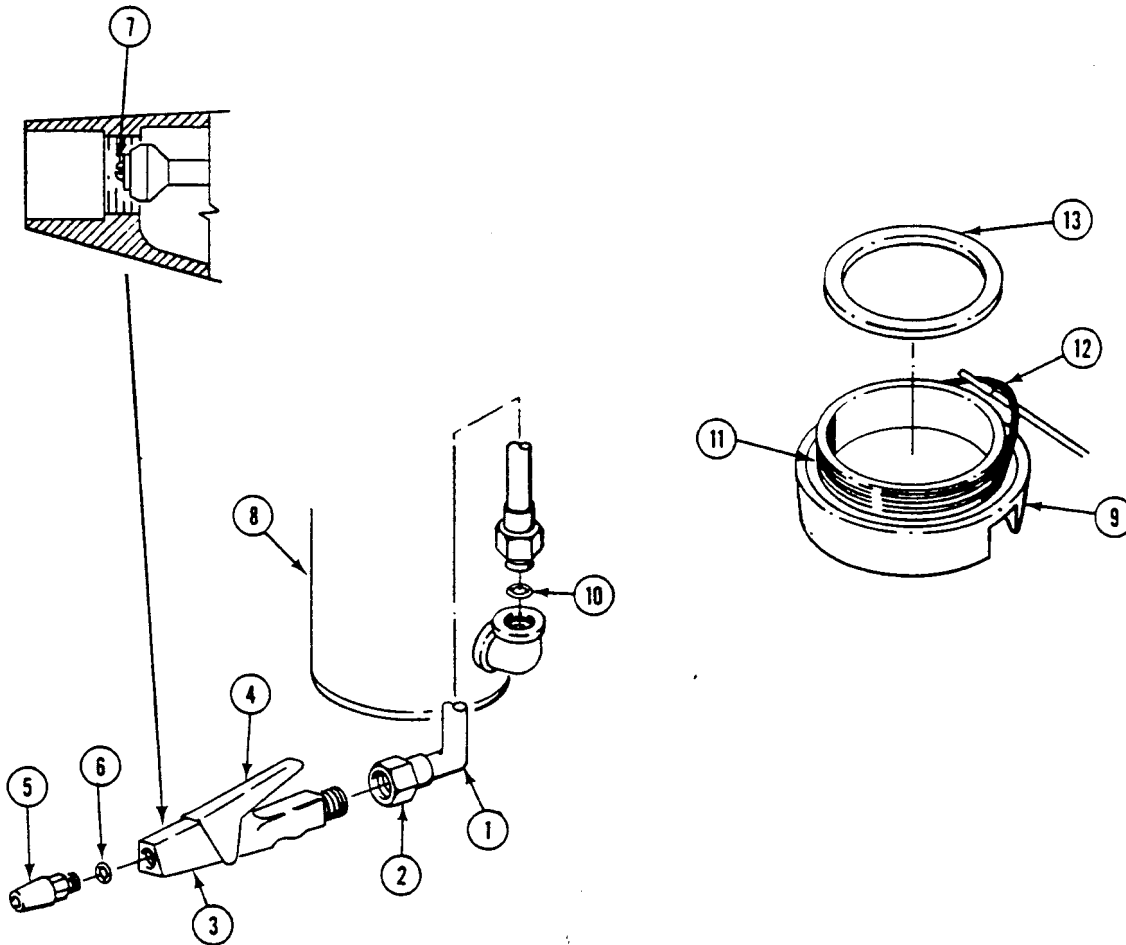

21. Thoroughly clean threads and gasket surface with stiff brush. Ensure pressure relief vent (1) grooves are unobstructed.
22. Thoroughly clean threads of top collar (2) with stiff brush. Wipe clean with a rag.

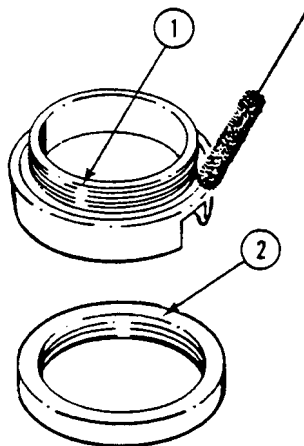

23. Remove retainer (3) and preformed packing (4) which secure stem indicator assembly (5). Clean or replace parts as required. Cap (6) should be replaced only if damaged.
24. Reassemble cap indicator (7). Reset indicator by pulling it in.

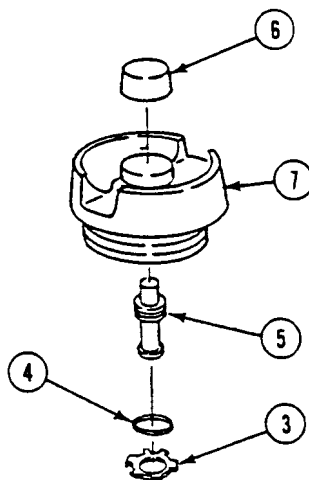

25. Clean gasket (8) and quad ring (9) with dry wiping rag. Inspect for cuts, breaks, wear, and elasticity.
26. Apply a thin coat of grease to gasket (8) surfaces.
27. Install gasket (8) and quad ring (9) on filler cap (10).

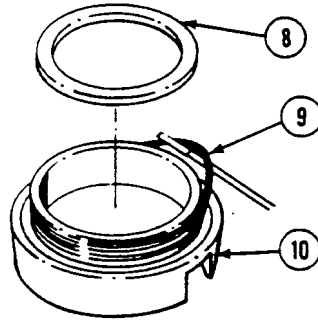

28. Ensure inside of shell (11) is clean and dry. Fill extinguisher with agent as required.
29. Install filler cap (10).
30. Lift puncture lever (12) and place hose (13) behind lever securing nozzle (14) in holder (15).

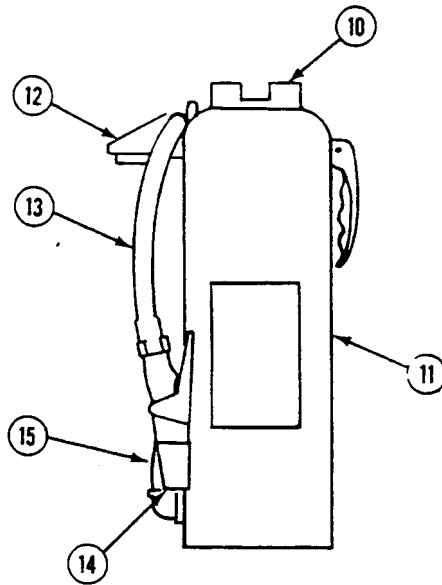

WARNING

Do not install cartridge without hose in place behind puncture lever. Cartridge will discharge if lever is pushed.

31. Install cartridge (1).
32. Install cartridge guard (2).
33. Install visual inspection seal wire (3).

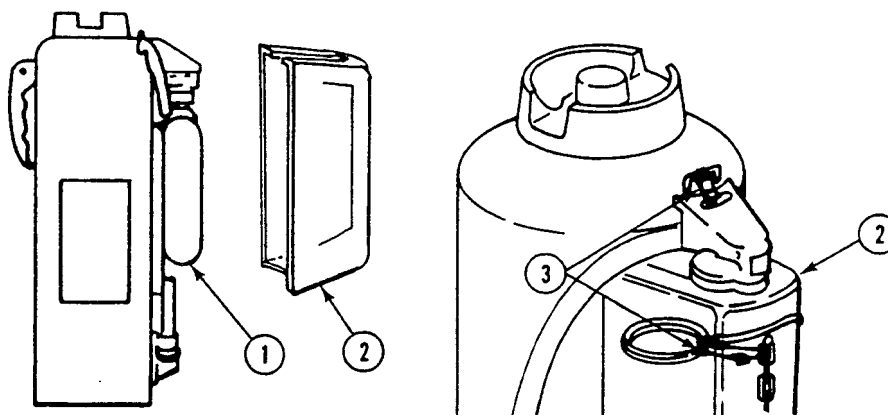
**FOLLOW-THROUGH STEPS**

1. Install fire extinguisher in carrier (see your -20).

END OF TASK

SERVICE FIRE EXTINGUISHER CYLINDER AND SAFETY DISC

0112 00

THIS WORK PACKAGE COVERS:

Servicing (page 0112 00-1).

INITIAL SETUP:

Maintenance Level

Direct Support

Tools and Special Tools

General Mechanic's Tool Kit (WP 0120 00, Item 62)

Materials/Parts

Disc

Gasket

Personnel Required

Track Vehicle Repairer 63H10

References

See your -10

See your -20

Equipment Condition

Engine stopped (see your -10)

Fire extinguisher cylinder removed from carrier (see your -20)

REMOVAL

WARNING



Fire bottles can discharge and injure you. Insert antirecoil plugs, lock pins, and cotter pins before you work on or near fire bottles.

You could be injured if cylinder discharges when it is out of its mounting brackets or is dropped. Discharge cylinder completely before removing from its mount. Handle with great care.

1. Remove safety disc nut (1) and safety disc (2) from cylinder valve (3). Discard safety disc.

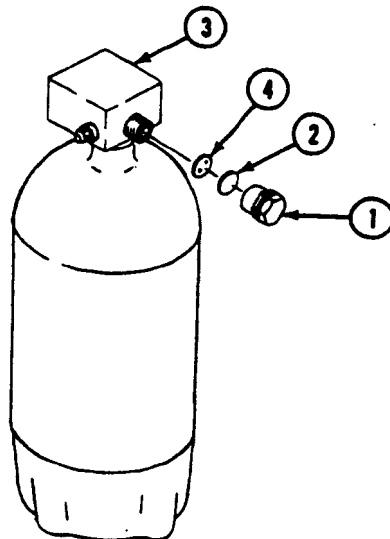

- Remove gasket (4) from cylinder valve (3). Discard gasket.

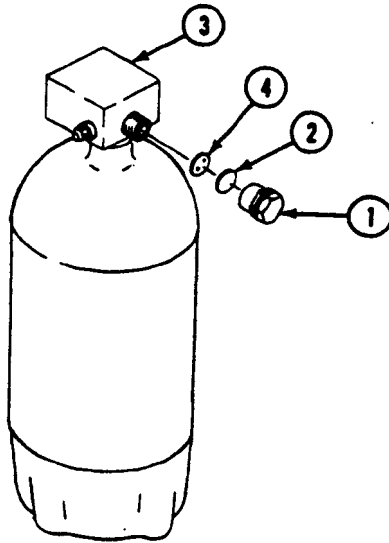

CLEAN, INSPECT, AND REPAIR

CAUTION

Do not allow cleaning solvent to enter cylinder valve housing. Internal parts may be damaged after assembly.

- Clean safety disc nut and cylinder valve (WP 0014 00). Dry parts.
- Check safety disc nut and cylinder valve for corrosion, cracks, damage, stripped threads, and metal particles remaining from safety disc and gasket. Repair or replace damaged safety disc nut or cylinder valve.

INSTALLATION

1. Install new gasket (4) in cylinder valve (3).

CAUTION

Dull side of safety disc must be against surface of gasket to prevent electrolytic corrosion of parts.

2. Install new safety disc (2) and safety disc nut (1) in cylinder valve (3).

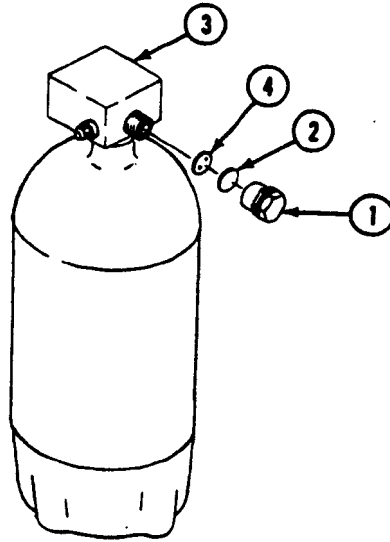
**FOLLOW-THROUGH STEPS**

1. Have fire extinguisher cylinder filled by the post fire station personnel.
2. Install full fire extinguisher cylinder in carrier (see your -20).

END OF TASK

CHAPTER 21

DIRECT SUPPORT MAINTENANCE INSTRUCTIONS
FOR SHIPPING CLOSURE AND FRAME

WORK PACKAGE INDEX

<u>Title</u>	<u>Sequence No.</u>
REMOVE SHIPPING CLOSURE AND FRAME (ALL EXCEPT M577A3 AND M1068A3).....	0113 00
REMOVE SHIPPING CLOSURE AND FRAME (M577A3 AND M1068A3 ONLY).....	0114 00

REMOVE SHIPPING CLOSURE AND FRAME (ALL EXCEPT M577A3 AND M1068A3)

0113 00

THIS WORK PACKAGE COVERS:

Removal (page 0113 00-1).

INITIAL SETUP:

Maintenance Level

Direct Support

Personnel Required

Track Vehicle Repairer 63H10

Tools and Special Tools

General Mechanic's Tool Kit (WP 0120 00, Item 62)

Equipment Condition

Carrier delivered to using troops

REMOVAL

NOTE

Do not damage or destroy the closure cover or frame. They can be used again. Turn them in to supply personnel.

1. Fold up cover (1). Release 16 straps (2).
2. Remove eight rods (3) from cover (1).
3. Remove cover (1) from frame (4).
4. Remove four screws (5), 12 washers (6), and four tiedown supports (7) from four track shroud holes (8).
5. Install setscrew (9) in track shroud hole (8).

REMOVE SHIPPING CLOSURE AND FRAME (ALL EXCEPT M577A3 AND M1068A3) —
Continued

0113 00

6. Remove four screws (10), nuts (11), eight washers (12), and four supports (7) from frame (4).
7. Remove frame (4) from carrier.

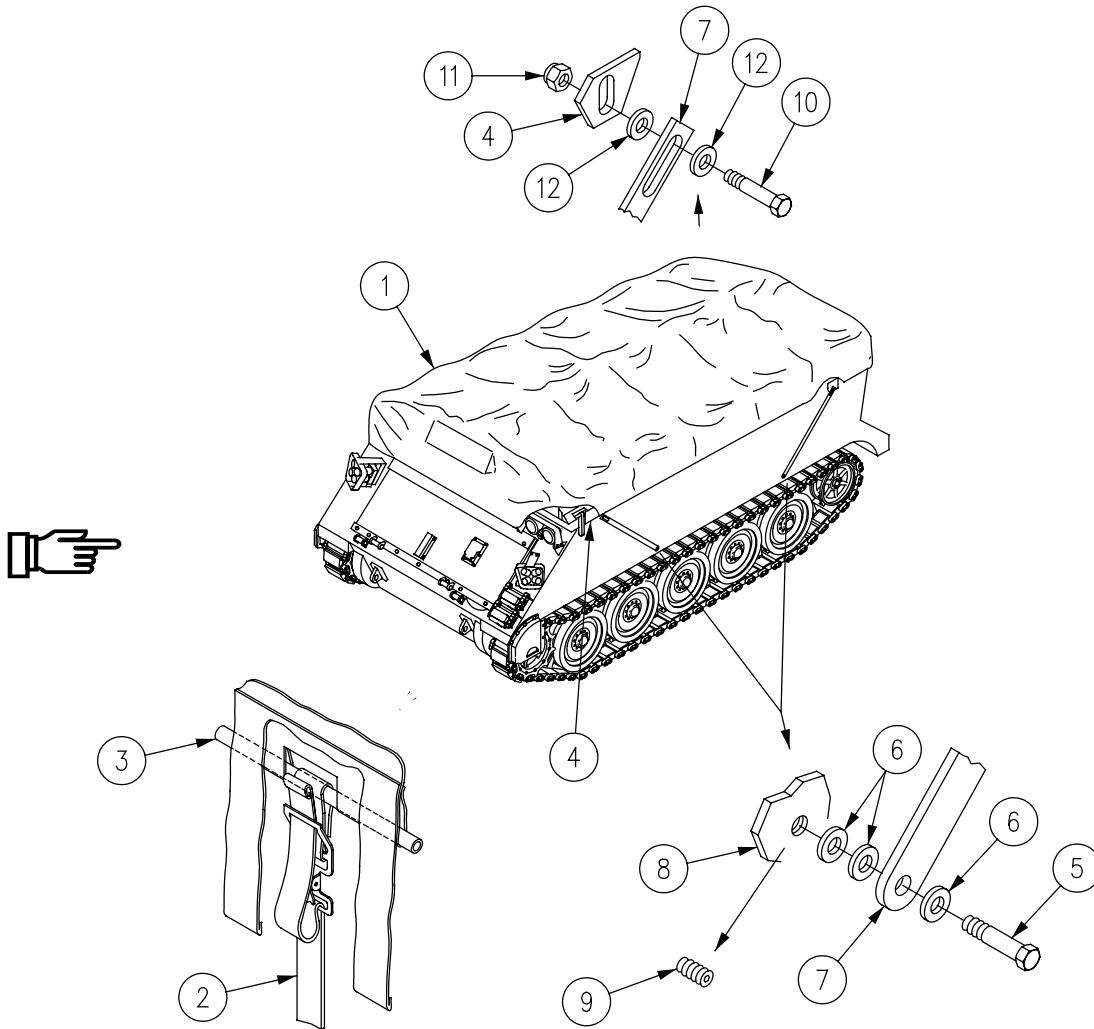

END OF TASK

REMOVE SHIPPING CLOSURE AND FRAME (M577A3 AND M1068A3 ONLY)

0114 00

THIS WORK PACKAGE COVERS:

Removal (page 0114 00-1).

INITIAL SETUP:

Maintenance Level

Direct Support

Personnel Required

Track Vehicle Repairer 63H10
Helper (H)

Tools and Special Tools

General Mechanic's Tool Kit (WP 0120 00, Item 62)

Equipment Condition

Carrier delivered to using troops

REMOVAL

NOTE

Do not damage or destroy the closure cover or frames. They can be used again. Turn them in to supply personnel.

1. Fold up cover (1). Release 20 rod clamps (2). Have helper assist.
2. Remove 10 rods (3) from cover (1).
3. Remove cover (1) from upper frame (4) and lower frame (5). Have helper assist.

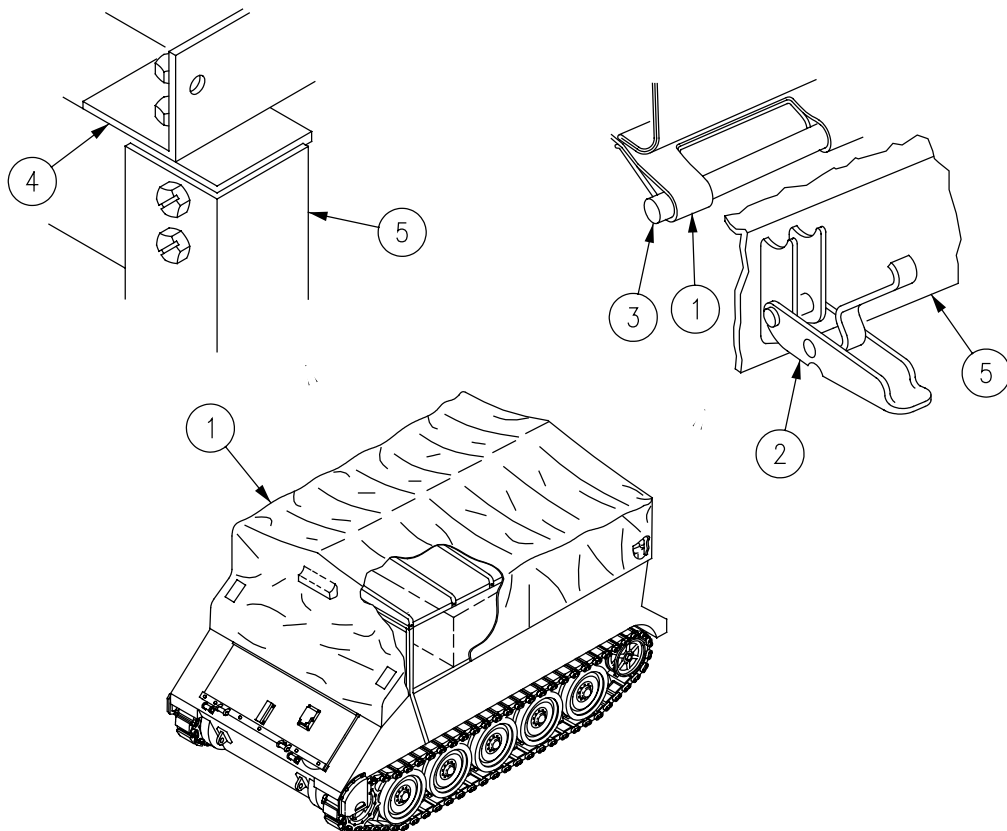

**REMOVE SHIPPING CLOSURE AND FRAME (M577A3 AND M1068A3 ONLY) —
Continued**

0114 00

4. Remove eight screws (1), nuts (2), and upper frame (3) from lower frame (4). Have helper assist.
5. Remove two screws (5), eight washers (6), and two frame supports (7) from track shroud hole (8).
6. Remove two screws (9), washers (10), nuts (11), and frame supports (7) from lower frame (4).
7. Remove two screws (12), washers (13), nuts (14), and lower frame (4) from two extension brackets (15).
8. Remove lower frame (4) from carrier. Have helper assist.

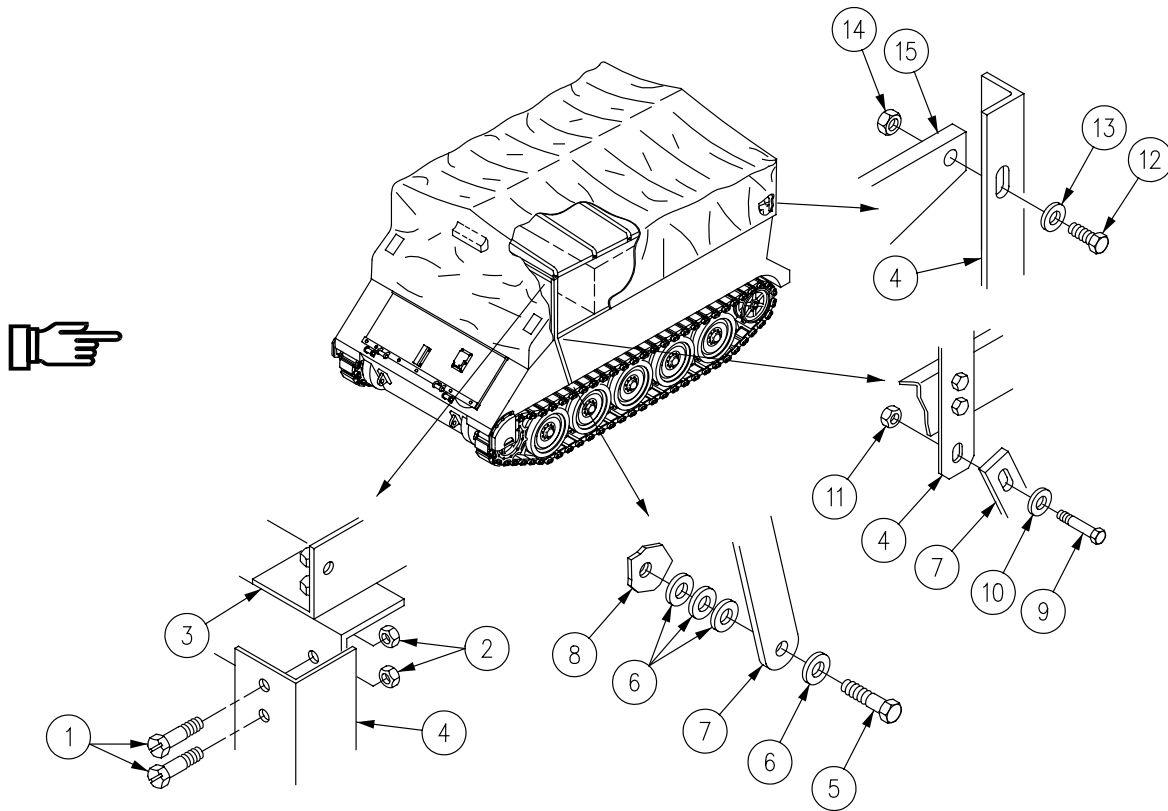

REMOVE SHIPPING CLOSURE AND FRAME (M577A3 AND M1068A3 ONLY) —
Continued

0114 00

9. Remove bolts (1) and washers (2) from driver's compartment.
10. Remove two end fittings (3), screws (4), nuts (5), and eight washers (6) from driver's compartment.
11. Install two end fittings (3) on two extension brackets (7). Secure with two screws (4), nuts (5), and eight washers (6).

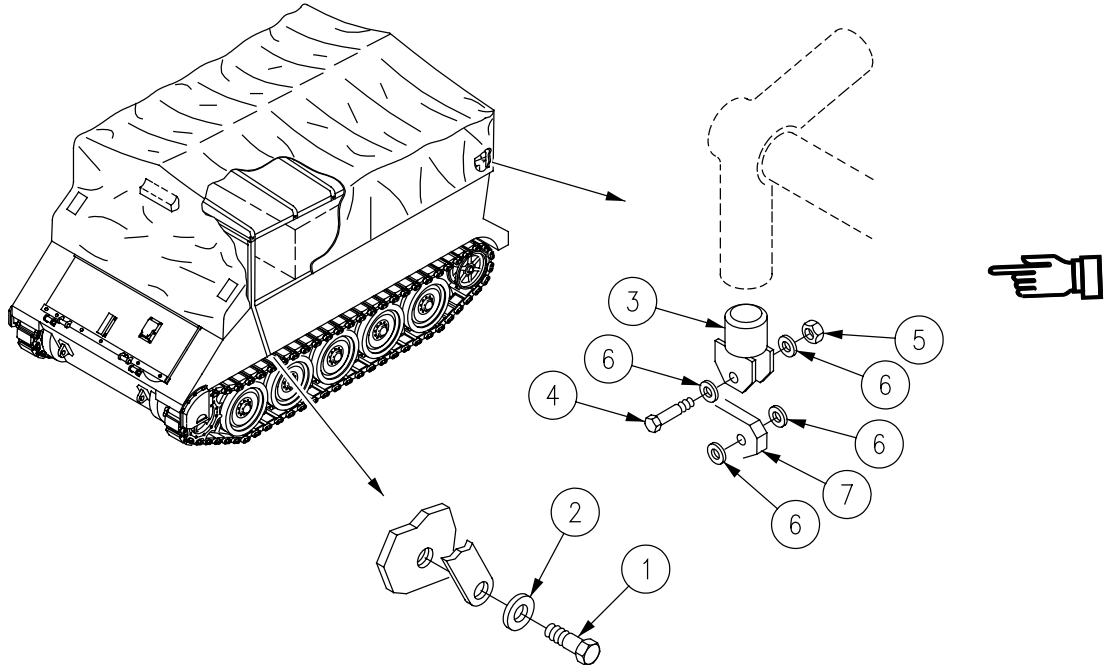

END OF TASK

CHAPTER 22

DIRECT SUPPORT MAINTENANCE INSTRUCTIONS
FOR GENERAL SUPPORT MAINTENANCE

WORK PACKAGE INDEX

<u>Title</u>	<u>Sequence No.</u>
REPAIR FAN AND GENERATOR VARIABLE SPEED DRIVE (OLD CONFIGURATION).....	0115 00
REPAIR/OVERHAUL FINAL DRIVE ASSEMBLY.....	0116 00
REPLACE LOCKED-IN STUDS (M577A3 ONLY).....	0117 00
REPLACE OVERSIZE SCREW INSERTS WITH LOCKRING.....	0118 00

**REPAIR FAN AND GENERATOR VARIABLE SPEED DRIVE
(OLD CONFIGURATION)**

0115 00

THIS WORK PACKAGE COVERS:

- Disassembly (page 0115 00-1).
- Assembly (page 0115 00-8).

INITIAL SETUP:

Maintenance Level

General Support

Tools and Special Tools

- General Mechanic's Tool Kit (WP 0120 00, Item 62)
- Screwdriver Bit (WP 0120 00, Item 4)
- Retaining Ring Pliers (WP 0120 00, Item 40)
- Arbor Press (WP 0120 00, Item 43)
- Puller Set (WP 0120 00, Item 45)
- Jacking Screw (3) (WP 0120 00, Item 50)
- Torque Wrench (WP 0120 00, Item 73)
- Torque Wrench (WP 0120 00, Item 74)

Materials/Parts

- Engine oil (WP 0122 00, Item 13)

Materials/Parts

- Encased seal (2)
- Encased seal
- Gasket
- Hose clamp, 2-inch (51-mm) diameter (2)
- Preformed packing
- Preformed packing
- Retaining ring (3)
- Seal (3)
- Shim stock, 0.020 in. x 6 in. x 1-1/2 in. (0.5 mm x 152 mm x 38 mm)

Personnel Required

- Track Vehicle Repairer 63H10
- Helper (H)

References

- See your -20

Equipment Condition

- Variable speed drive assembly removed (see your -20)

DISASSEMBLY

CAUTION

Cast aluminum can be damaged. Do not overtighten or mar in holding fixture.

1. Place drive assembly (1) in a suitable holding fixture. Have helper assist.
2. Secure generator pulley (2), and remove screw (3) and washer (4).

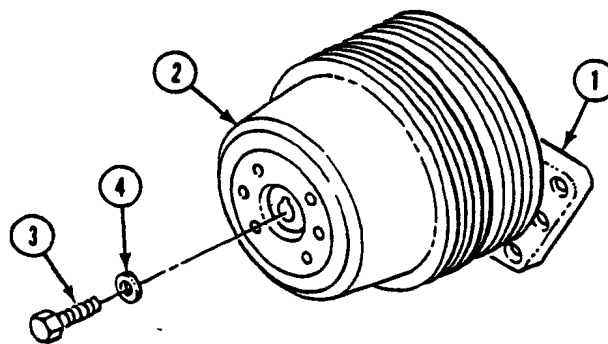

REPAIR FAN AND GENERATOR VARIABLE SPEED DRIVE (OLD CONFIGURATION) — Continued

0115 00

3. Install three jacking screws (5) in generator pulley (6).

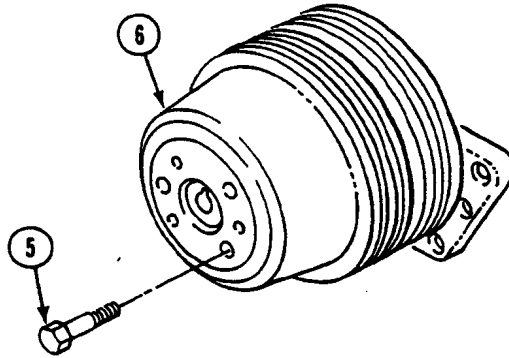

4. Using three jacking screws (1), separate generator pulley (2) from fan pulley (3). Remove preformed packing (4) and key (5). Discard preformed packing.
5. Secure fan pulley (3) in holding fixture.

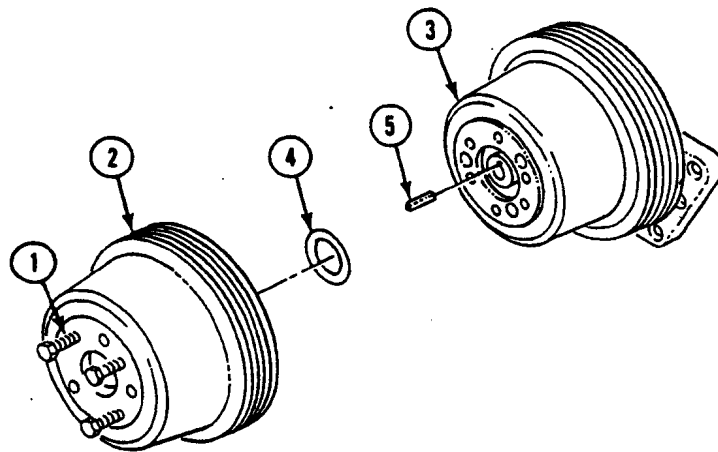

REPAIR FAN AND GENERATOR VARIABLE SPEED DRIVE (OLD CONFIGURATION) — Continued

0115 00

6. Remove six screws (6) and washers (7) from fan pulley (3). Separate fan pulley from inner housing assembly (8).
7. Reverse housing assembly (8) in holding fixture.

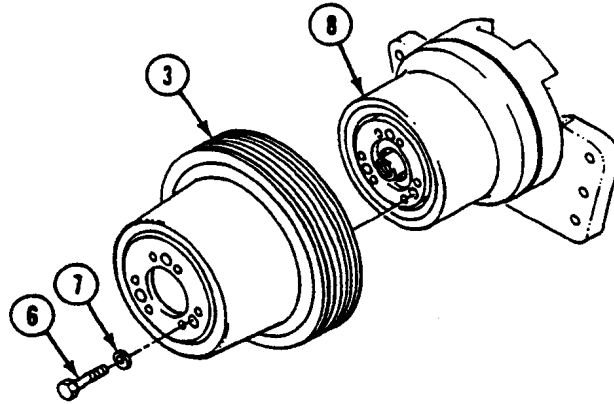
**NOTE**

Use two of the screws removed in Step 8 as jacking screws to remove cover plate.

8. Remove six screws (9) and washers (10) from cover plate (11). Install two jacking screws in threaded holes of cover plate.

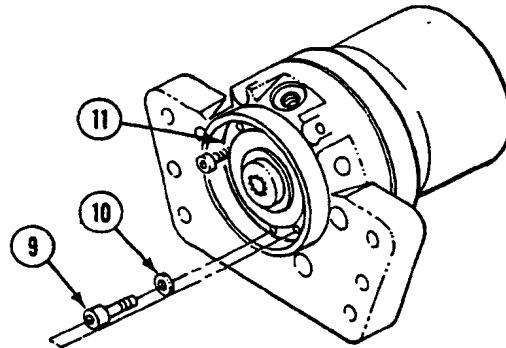

REPAIR FAN AND GENERATOR VARIABLE SPEED DRIVE (OLD CONFIGURATION) — Continued

0115 00

9. Remove cover plate (2) and preformed packing (5) from rear housing (4). Discard preformed packing. Remove two jacking screws (6) from cover plate.
10. Press encased oil seal (1) out of cover plate (2). Discard oil seal.

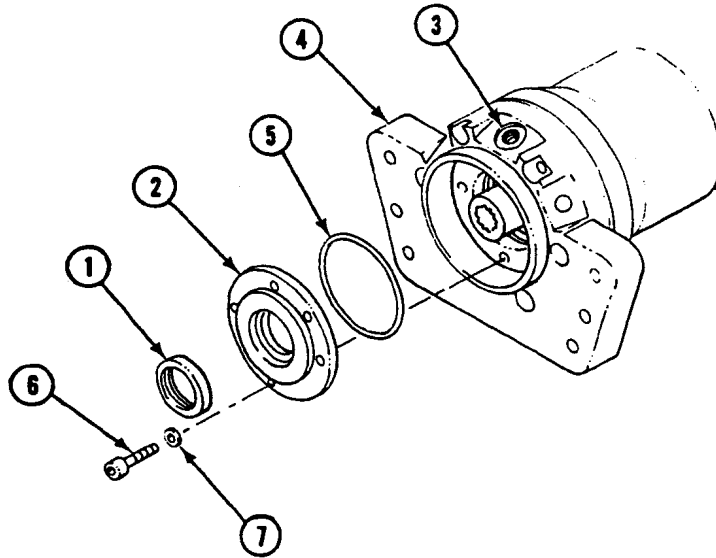

11. Remove six screws (1) and washers (2) from front housing (3).

NOTE

When the front housing is separated from the rear housing, the inner housing with shaft and clutch assembly may stay with the front housing.

12. Separate front housing (3) from rear housing (4). Tap off at shaft with rubber hammer.
13. Remove gasket (5) from rear housing (4). Discard gasket.

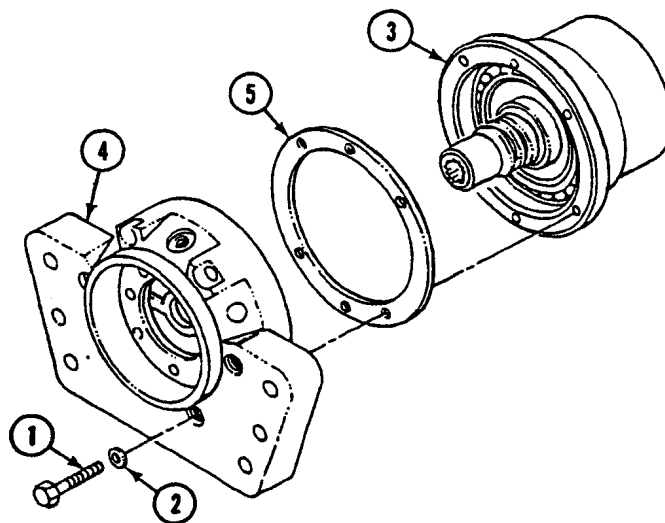

14. Remove the large lock ring (6) that secures the clutch housing assembly (7) to the front housing (3).

NOTE

If bearing (8) remains inside of front housing (3), go to Step 29 for bearing removal. If bearing remains on inner housing (7), go to Step 23. After removal of bearing, return to Step 16.

15. Press clutch housing assembly (7) (with shaft and clutch) out of front housing (3).

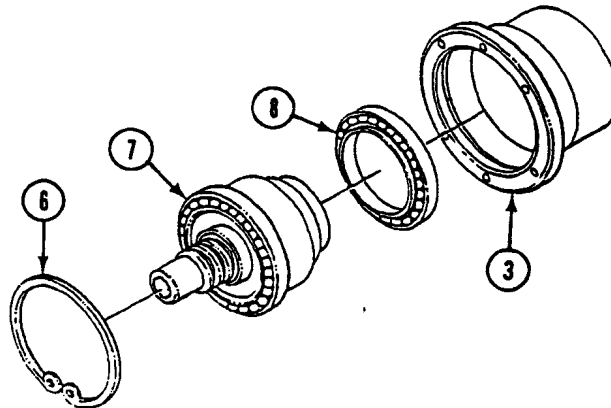

16. Press shaft and clutch assembly (9) out of inner housing (10).

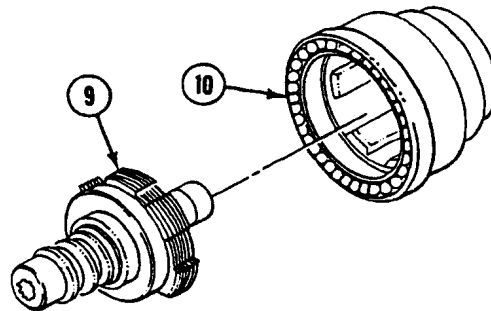

17. Remove spacer (11) from shaft (12).

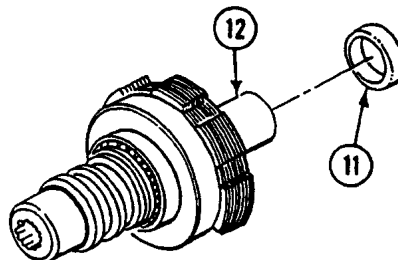

REPAIR FAN AND GENERATOR VARIABLE SPEED DRIVE (OLD CONFIGURATION) — Continued

0115 00

18. Press shaft (1) out of clutch (2).
19. Remove key (3) from shaft (1).
20. Press bearing (4) from shaft (1).
21. Remove three rings (5) from shaft (1). Discard rings.

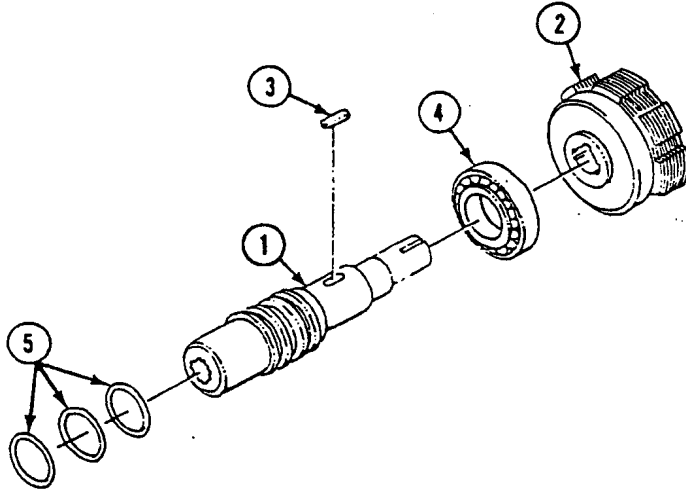

22. Press larger bearing (6) from the inner housing (7).
23. Remove bearing (8) from inner housing (7). Use puller.

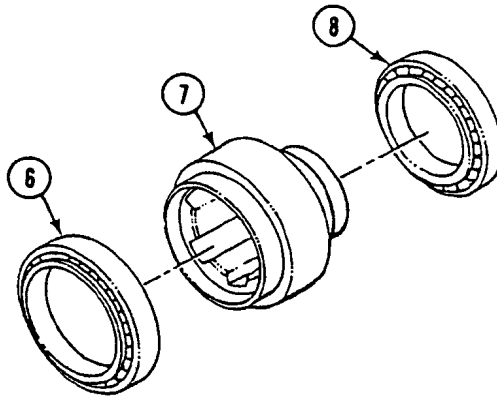

REPAIR FAN AND GENERATOR VARIABLE SPEED DRIVE (OLD CONFIGURATION) — Continued

0115 00

24. Remove lock ring (9) from inner housing (7).
25. Remove bearing (10) from inner housing (7). Use puller.
26. Remove oil seal (11) from inner housing (7). Discard oil seal.

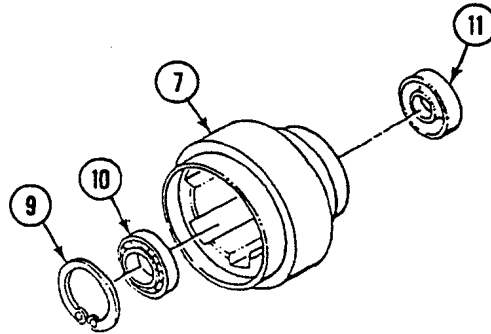

27. Remove lock ring (12) from front housing (13).
28. Remove encased oil seal (14) from the front housing (13). Discard oil seal.

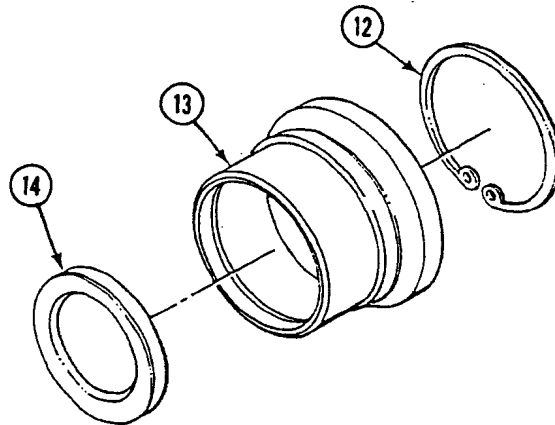

REPAIR FAN AND GENERATOR VARIABLE SPEED DRIVE (OLD CONFIGURATION) — Continued

0115 00

29. Press bearing (1) from front housing (2).

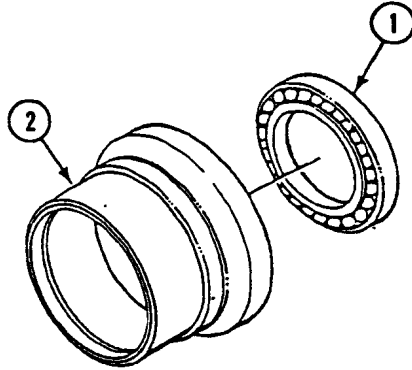
ASSEMBLY

1. Install lock ring (3) in front housing (2).

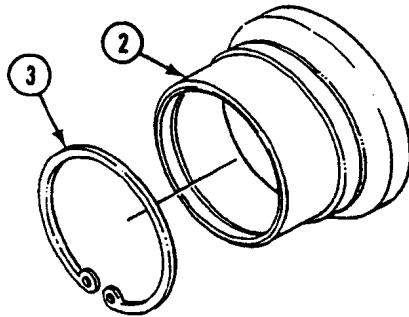

2. Install new encased oil seal (11) in inner housing (7).

3. Press bearing (10) into inner housing (7).

4. Install lock ring (9) in inner housing (7).

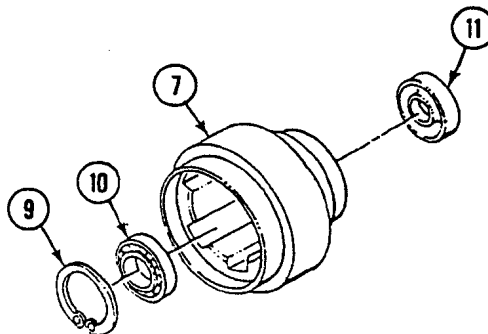

5. Press smaller bearing (8) on inner housing (7).

REPAIR FAN AND GENERATOR VARIABLE SPEED DRIVE (OLD CONFIGURATION) — Continued

0115 00

6. Press bearing (6) on inner housing (7).

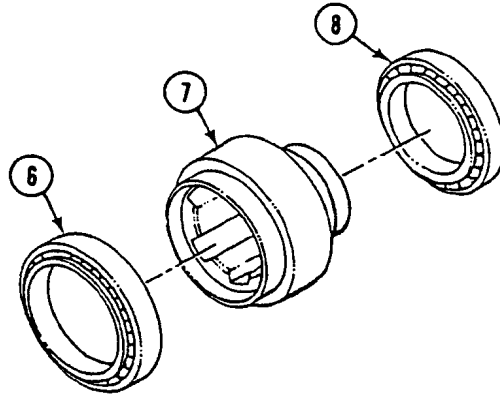

7. Coat three new rings (5) with lubricating oil. Install three rings on shaft (1).
8. Press bearing (4) on shaft (1).
9. Install key (3) on shaft (1).
10. Lightly lubricate shaft (1) before installing clutch (2).
11. Press clutch (2) onto shaft (1).

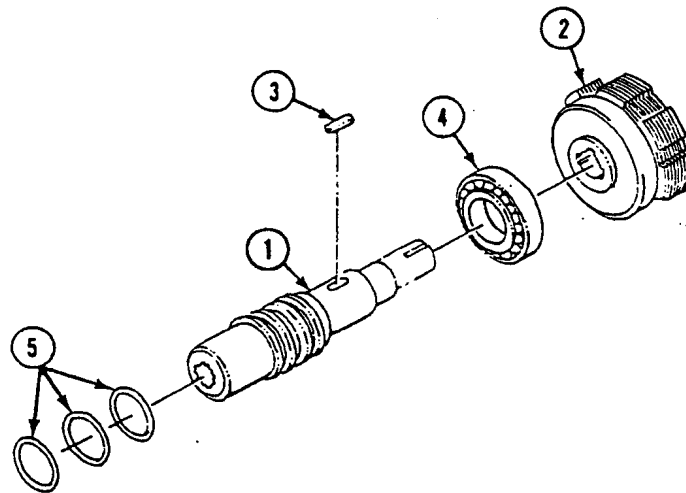

12. Install spacer (11) on shaft (12).

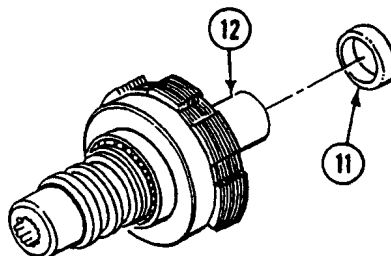

REPAIR FAN AND GENERATOR VARIABLE SPEED DRIVE (OLD CONFIGURATION) — Continued

0115 00

13. Aline ring tabs (3) on clutch assembly (4) before installing shaft in housing (5).
14. Press shaft and clutch assembly (4) into inner housing (5).

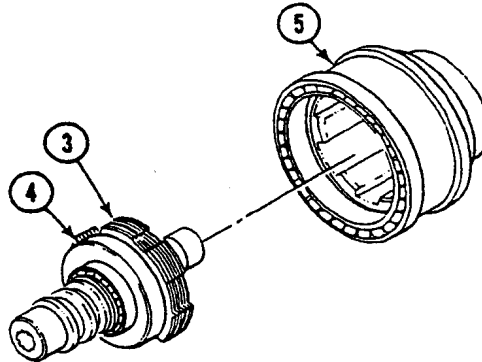

15. Lightly lubricate both outer bearing races.
16. Support front housing (6) only during installation of inner housing (7) on arbor press to allow inner housing to extend down past front housing edge.
17. Press inner housing (8) (with clutch and shaft) into the front housing (6).
18. Install large lock ring (9) that secures the inner housing (8) to the front housing (6).
19. Lubricate new encased oil seal (10).
20. Install new encased oil seal (10) into front housing (6). Use brass drift and hammer.

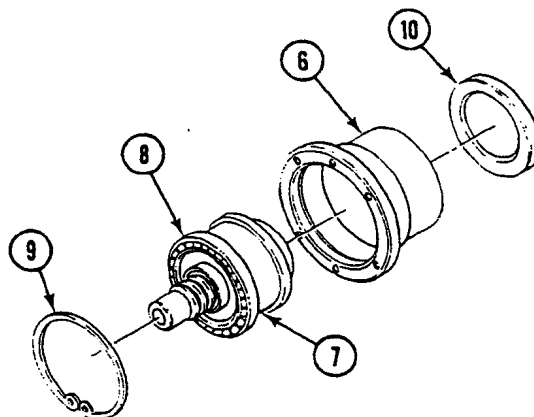

REPAIR FAN AND GENERATOR VARIABLE SPEED DRIVE (OLD CONFIGURATION) — Continued

0115 00

21. Install new gasket (5) on rear housing (4).
22. Using .020-inch (.5-mm) shim stock and two 2-inch (51-mm) diameter hose clamps, compress three new rings on shaft. Allow to seat for thirty minutes. Remove both clamps and shim stock.
23. Install front housing (3) on rear housing (4).
24. Install six screws (1) and washers (2) to secure front housing (3) to rear housing (4). TIGHTEN SCREWS TO 210-220 LB-IN (24-25 N·m) TORQUE.

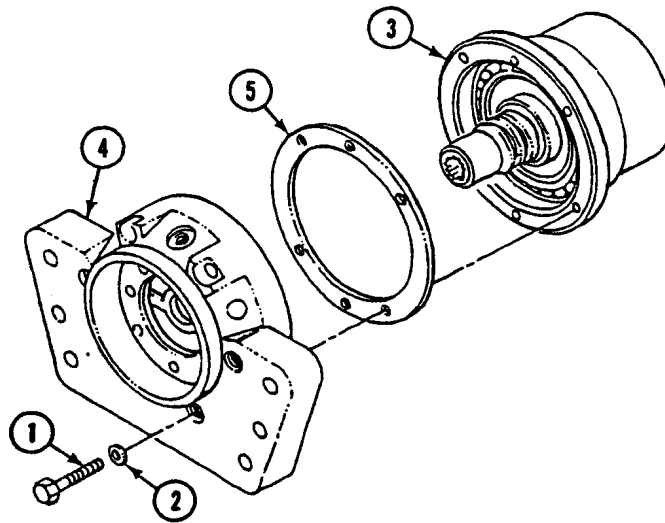

REPAIR FAN AND GENERATOR VARIABLE SPEED DRIVE (OLD CONFIGURATION) — Continued

0115 00

25. Install new encased oil seal (1) in cover plate (2).
26. Pump oil through lower oil passage (3) until rear housing (4) is full.
27. Lubricate new preformed packing (5) and install on cover plate (2). Install cover plate (2) on rear housing (4).
28. Install six screws (6) and washers (7) to secure cover plate (2). TIGHTEN SCREWS TO 100-105 LB-IN (11-12 N·m) TORQUE.
29. Install protective plugs in three rear ports.

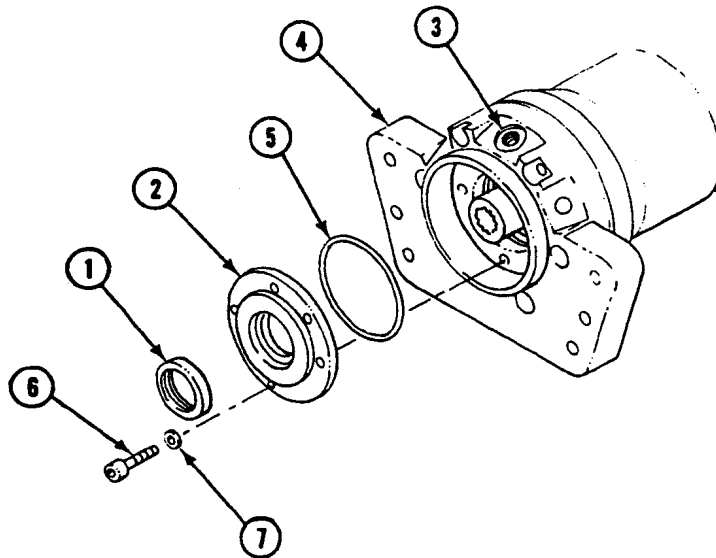

30. Reverse housing assembly (8).
31. Install fan pulley (3) on housing assembly (8). Secure pulley with six screws (6) and washers (7). TIGHTEN SCREWS TO 210-220 LB-IN (24-25 N·m) TORQUE.

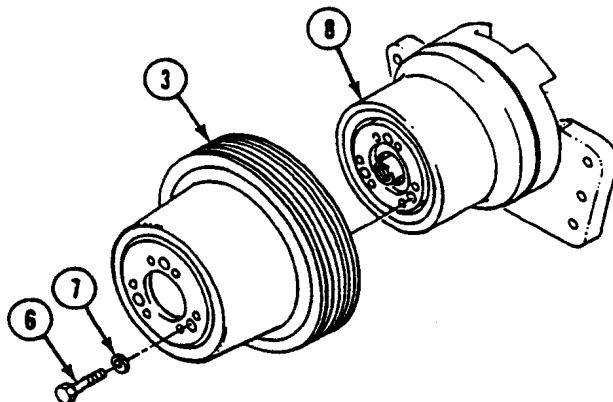

REPAIR FAN AND GENERATOR VARIABLE SPEED DRIVE (OLD CONFIGURATION) — Continued

0115 00

32. Lubricate new preformed packing (11) and install on generator pulley (12).
33. Install key (13) on shaft (14).
34. Install generator pulley (12) on fan pulley (15). Secure with screw (16) and washer (17). TIGHTEN SCREW TO 76-79 LB-FT (103-108 N·m) TORQUE.

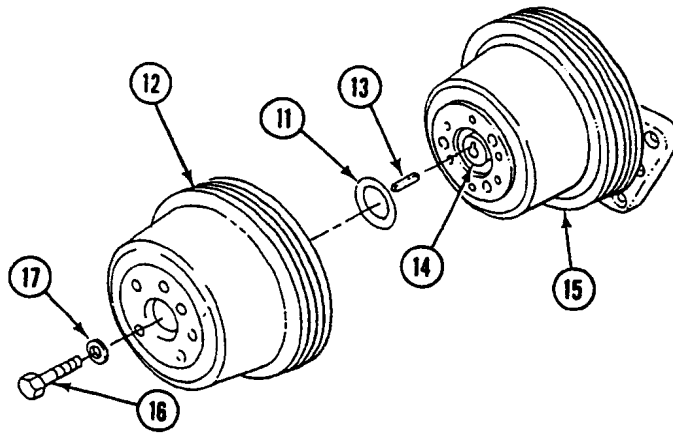
**FOLLOW-THROUGH STEPS**

1. Install fan and generator variable speed drive assembly (see your -20).

END OF TASK

REPAIR/OVERHAUL FINAL DRIVE ASSEMBLY

0116 00

THIS WORK PACKAGE COVERS:

Repair or Replacement (page 0116 00-1).

INITIAL SETUP:

Maintenance Level

General Support

References

TM 9-2520-238-34

See your -20

Personnel Required

Track Vehicle Repairer 63H10

Equipment Condition

Final drive assembly removed (see your -20)

REPAIR OR REPLACEMENT

1. To repair/overhaul final drive assembly, see TM 9-2520-238-34.

END OF TASK

REPLACE LOCKED-IN STUDS (M577A3 ONLY)

0117 00

THIS WORK PACKAGE COVERS:

Removal (page 0117 00-1).
 Installation (page 0117 00-1).

INITIAL SETUP:

Maintenance Level

General Support

Personnel Required

Track Vehicle Repairer 63H10

Tools and Special Tools

General Mechanic's Tool Kit (WP 0120 00, Item 62)
 Portable Electric Drill (WP 0120 00, Item 7)
 Drill Set (WP 0120 00, Item 9)
 Lock ring drive tool (WP 0120 00, Item 13)
 Extractor Screw Set (WP 0120 00, Item 14)
 Hacksaw (WP 0120 00, Item 17)
 Screw Threading Set (WP 0120 00, Item 58)

References

See your -10

Equipment Condition

Engine stopped (see your -10)
 Carrier blocked (see your -10)

Materials/Parts

Stud
 Hacksaw blade (WP 0122 00, Item 15)

REMOVAL

1. Use a hacksaw to cut off broken stud as close to mounting surface as you can.
2. If a locked stud with serrated locking is being removed, punch center of remaining stud. Drill a pilot hole.

NOTE

Key-locked studs have predrilled pilot holes.

3. Use an extractor to remove stud. Discard stud.

INSTALLATION

1. Use correct size tap drill (see Table 1, page 0117 00-3) to drill hole for stud.
2. Tap threads. See Table 1, page 0117 00-3 for correct thread size.
3. Install new stud in threaded hole.

- If stud cannot be turned by hand, lock two jamnuts on nut end of stud. Then turn with a wrench.

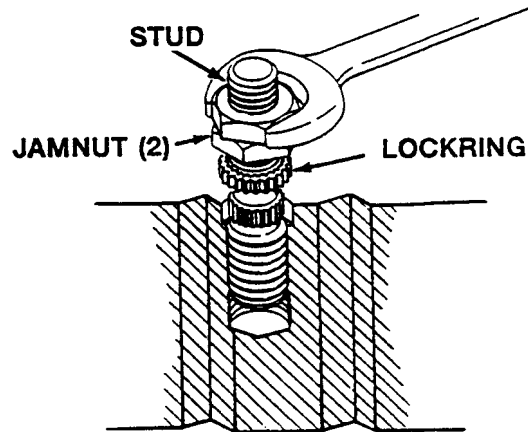

**A. INSTALL STUD
USING TWO JAMNUTS**

NOTE

See Table 1, page 0117 00-3 for correct nut thread size.

- Remove jamnuts.
- If stud with serrated lockring is to be installed, place lockring on stud.
- Cut off a piece of heavy walled pipe or tubing to fit over stud as shown Step 8. See (WP 0121 00) for fabrication instructions.

NOTE

Installation of key-locked stud is similar to installation of stud with serrated locking. Make sure fabricated pipe or tubing bears on keys. Drive straight down. Avoid breaking keys.

NOTE

Do not drive upper edge of locking below upper edge of serrated part of stud. Drive straight down.

8. Use a hammer to drive keys or locking down to secure stud.

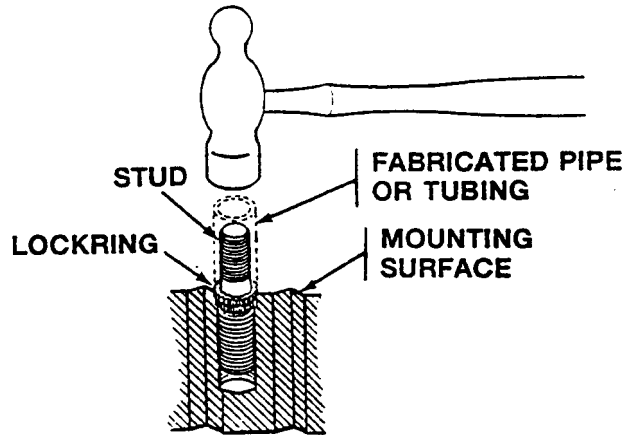

B. PLACE TUBE ON LOCKRING AND DRIVE FLUSH WITH MOUNTING SURFACE

9. Drive keys flush with mount surface.

Table 1. LOCKED-IN STUDS

Nut and Thread Size	NSN or Part Number	Stud End	Application
3/8-24NF-3A	Stud- *5307-00-965-5686 10932377 (19207) Lock- 5365-00-735-0196 ring 7350196 (19207)	7/16-14UNC-2A (33/64 (13 mm) counterbore)	Covered extension (M577A3)
* Screw thread stud with serrated locking.			

END OF TASK

REPLACE OVERSIZE SCREW INSERTS WITH LOCKRING

0118 00

THIS WORK PACKAGE COVERS:

Installation (page 0118 00-1).

INITIAL SETUP:

Maintenance Level
General Support

Screw Threading Set (WP 0120 00, Item 58)

Personnel Required

Track Vehicle Repairer 63H10

Tools and Special Tools

General Mechanic's Tool Kit (WP 0120 00, Item 62)
Oversize Rosan Insert Tool Kit (WP 0120 00, Item 64)
Portable Electric Drill (WP 0120 00, Item 7)
Drill Set (WP 0120 00, Item 9)
Thread Inserter Holder Kit (WP 0120 00, Item 23)

Equipment Condition

Engine stopped (see your -10)
Carrier blocked (see your -10)
Road wheel support arm removed (see your -20)

INSTALLATION

1. Align bushing hole of body (1) with existing insert hole in hull.

NOTE

Cap screw thread size must be the same size as inside thread of hull insert.

2. Install body (1) on hull. Secure with cap screw (2) and flat washer (3). Screw cap screw into a serviceable thread insert or tapped hole.

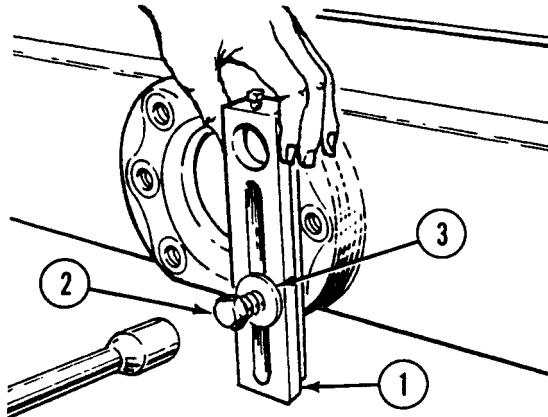

3. Install correct size bushing (4) in body (1). Secure with set screw (5).

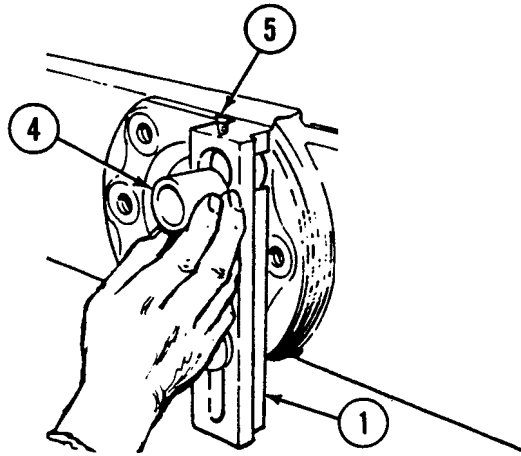

4. Use a hand drill and correct size counterbore drill (1) to drill through bushing (2) into hull to the depth of insert to be installed.
5. Counterbore to depth of lockring thickness plus 0.010 to 0.020 inch (0.254 to 0.508 mm).

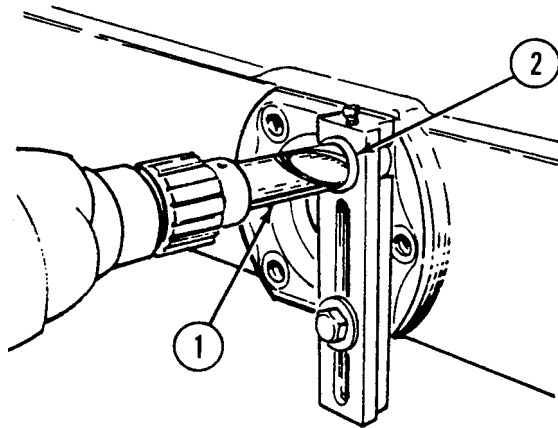

6. Hand tap correct size threads.

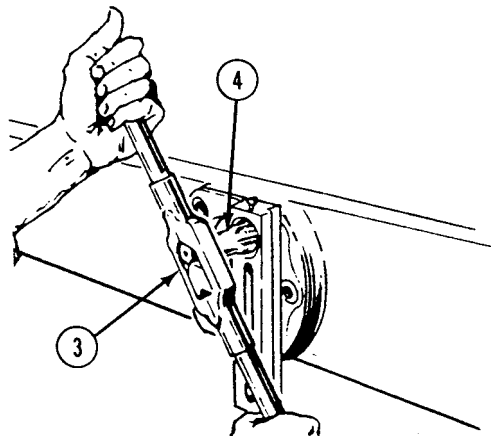

7. Use wrench (3) to install oversize insert (4) in threaded hole.

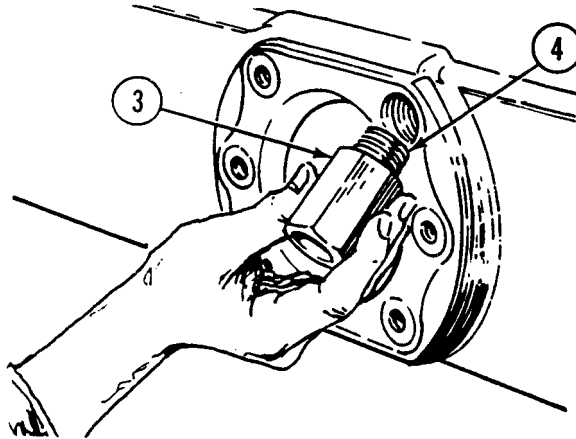

8. Install oversize locking (5) flush with hull surface. Use drive tool (6).

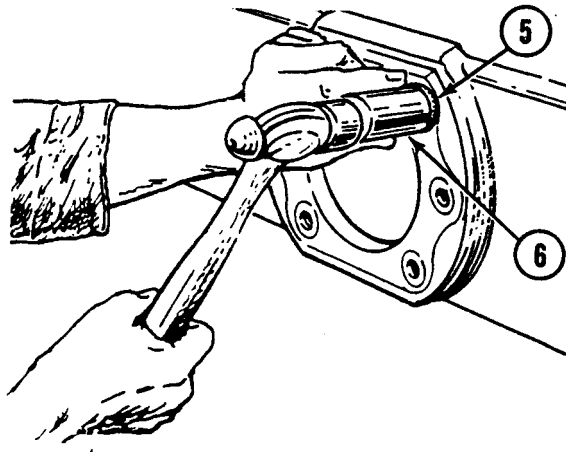

OVERSIZE INSERT TECHNICAL DATA

INTERNAL THREAD SIZE	OVERSIZE INSERT PART NUMBER/NSN	LOCK RING PART NUMBER/NSN
1/4-28 UNF	R231SB9L 5340-00-701-7231	RL31SB9 5365-00-281-3146
3/8-16UNC	R133SB11L 5340-00-701-7266	RL47SB10 5365-00-281-9221
1/2-20 UNF	R235SB16L 5340-00-701-7294	RL64SB11 5365-00-282-4566
5/8-18 UNF	R337SB18L	RL82SB12 5365-00-595-9726
3/4-16 UNF	R338SB-20L 5340-00-701-7329	RL90SB12 5365-00-200-7742

FOLLOW-THROUGH STEPS

1. Install road wheel support arm (see your -20).

END OF TASK

CHAPTER 23

DIRECT SUPPORT SUPPORTING INFORMATION

WORK PACKAGE INDEX

<u>Title</u>	<u>Sequence No.</u>
REFERENCES.....	0119 00
COMMON TOOLS AND SUPPLEMENTS AND SPECIAL TOOLS/FIXTURES LIST.....	0120 00
FABRICATED TOOLS.....	0121 00
EXPENDABLE/DURABLE SUPPLIES AND MATERIALS LIST.....	0122 00

REFERENCES

0119 00

SCOPE

This appendix lists all forms, field manuals, technical manuals, Department of the Army pamphlets and regulations, and miscellaneous publications referenced in this manual.

FORMS

Processing and Deprocessing Record for Shipment, Storage, and Issue of Vehicles and Spare Engines.....DD Form 1397

Recommended Changes to Publications and Blank Forms.....DA Form 2028

Quality Deficiency Report.....SF 368

LUBRICATION ORDERS

Lubrication Order: Carrier, Personnel, Armored, M113A3 (2350-01-219-7577); Carrier, Command Post, M577A3 (2350-01-369-6085); Carrier, Anti-Tank, (TOW), M901A3, (2350-01-369-7253); Carrier, Fire Support Personnel, M981A3 (2350-01-369-6079); Carrier, Smoke Generator, M1059A3 (2350-01-369-6083); Carrier, Mortar, 120-MM M121, M1064A3 (2350-01-369-6082); Carrier, Standardized Integrated Command Post System (SICPS), M1068A3 (2350-01-369-6086); Chassis, Mechanized Smoke Obscurant, M58 (2350-01-418-6654).....LO 9-2350-277-12

FIELD MANUALS

First Aid for Soldiers.....FM 21-11

Fundamentals of Machine Tools.....FM 9-24

General Fabric Repair.....FM 10-16

Metal Body Repair and Related Operations.....FM 43-2

Operation and Maintenance of Ordnance Materiel in Cold Weather (0 to -65 deg F).....FM 9-207

TECHNICAL MANUALS

Ammunition and Explosive Standards.....TM 9-1300-206

Cooling Systems: Tactical Vehicles.....TM 750-254

Destruction of Conventional Ammunition and Improved Conventional Munitions to Prevent Enemy Use.....TM 750-244-5-1

Direct Support and General Support Maintenance: Right Angle Drive, Cooling Fan; Gearcase, Transfer; Drive Assembly, Final; Differential, Steering Control; Brake, Single Disk; Cylinder Assembly, Hydraulic Brake.....TM 9-2520-238-34

Direct Support and General Support Maintenance for: Engine w/Container: Model 5063-5299 (2815-00-124-5390)(2815-01-295-7458); Engine w/Container: Model 5063-5392 (2815-01-246-0903); Engine w/Container: Model 5063-5393 (2815-01-248-7644); Engine w/Container: Model 5063-5395 (2815-01-031-6154); Engine w/Container: Model 5063-5398 (2815-00-909-5949); Engine w/Container: Model 5063-539F (2815-01-316-6617).....TM 9-2815-205-34

Direct Support and General Support Maintenance for: Periscope, Tank: M19, Old and New Configuration (6650-00-765-2971)(1240-01-005-6035); Periscope, Tank: M24, Old and New Configuration (6650-00-344-4647) (1240-01-005-6036).....TM 9-1240-216-34

REFERENCES—Continued

0119 00

Direct Support and General Support Maintenance, Repair Parts, and Special Tools List
(Including Depot Maintenance Repair Parts): Engine w/Container: Model 5063-5299
(2815-00-124-5390)(2815-01-295-7458); Engine w/Container: Model 5063-5392
(2815-01-246-0903); Engine w/Container: Model 5063-5393 (2815-01-248-7644);
Engine w/Container: Model 5063-5395 (2815-01-031-6154); Engine w/Container:
Model 5063-5398 (2815-00-909-5949); Engine w/Container: Model 5063-539F
(2815-01-316-6617); Engine w/Container: Model 5063-539L (2815-01-412-2715).....TM 9-2815-205-34P

Direct Support and General Support Maintenance, Repair Parts, and Special Tools Manual for
Generator, Alternating Current, 200 AMPS (2920-01-147-1575) Leece-Neville Model
A0012260.....TM 9-2920-257-30&P

Direct Support and General Support Maintenance, Repair Parts, and Special Tools Lists
(Including Depot Maintenance Allowances): Generator, Engine Accessory, Alternating
Current, Prestolite Model AMA-5102UT; Leece-Neville Models 3002AC and 3002AD,
5504AA and 5504AB, 22184AC and 5300GP, and Regulator, Generator, Leece-Neville
Model 3392R12P (FSN 2920-540-9476).....TM 9-2920-247-34P

Inspection, Care, and Maintenance of Antifriction Bearings.....TM 9-214

Intermediate, Direct and General Support Maintenance Manual (Including Repair Parts
and Special Tools List): Cross Drive Transmission w/Container Model X200-4
(2520-01-201-4784) Allison Transmission Division, GMC.....TM 9-2520-272-34&P

M1068 Standardized Integrated Command Post System.....TM11-7010-256-12&P

Operator, Organizational, Direct Support and General Support Maintenance Manual:
Lead-Acid Storage Batteries.....TM 9-6140-200-14

Operator, Organizational, Direct Support and General Support Maintenance Manual: Welding
Set, Arc, Inert Gas Shielded; Plastic or Metal-lined Gun; for 3/4 Inch Wire; DC, 115V
(Westinghouse Model SA-135) (FSN 3431-879-9709).....TM 5-3431-200-15

Operator's and Organizational Maintenance Manual (Including Repair Parts and Special Tools
List): Decontaminating Apparatus: Portable, 14 Liter, M13.....TM 3-4230-214-12&P

Operator's Manual: Generator, Smoke, Mechanical: Mechanized Smoke Obscurant System,
M58 (1040-01-413-8332).....TM 3-1040-285-10

Operator's Manual: Generator Set, Smoke, Mechanical: Pulse Jet M157A2.....TM 3-1040-283-10

Operator's Manual: Carrier, Personnel, Armored, M113A3 (2350-01-219-7577); Carrier,
Command Post, M577A3 (2350-01-369-6085); Carrier, Smoke Generator, M1059A3
(2350-01-369-6083); Carrier, Mortar, 120-MM M121, M1064A3 (2350-01-369-6082);
Carrier, Standardized Integrated Command Post System (SICPS), M1068A3
(2350-01-369-6086); Chassis, Mechanized Smoke Obscurant, M58 (2350-01-418-6654).....TM 9-2350-277-10

REFERENCES—Continued

0119 00

Operator’s Manual: Welding Theory and Application.....TM 9-237

Operator’s, Unit, and Direct Support Maintenance Manual (Including Repair Parts and Special Tools List): Modular Command Post System (MCPS).....TM 10-5410-229-13&P

Organizational, DS and GS Maintenance Manual: Standards For Inspection and Classification of Tracks, Track Components and Solid Rubber Tires.....TM 9-2530-200-24

Organizational, DS and GS Maintenance Manual (Including Repair Parts and Special Tools List) for Heater, Vehicular Compartment (2540-01-396-2826): Model A-20.....TM 9-2540-207-14&E

Painting Instructions for Army Materiel.....TM 43-0139

Preparation and Inspection of Industrial Equipment for Storage or Shipment.....TM 38-260

Preservation, Packaging, and Packing of Military Supplies and Equipment —Preservation and Packaging (VOL I).....TM 38-230-1

Preservation, Packaging, and Packing of Military Supplies and Equipment —Preservation and Packaging (VOL II).....TM 38-230-2

Procedures for Destruction of Electronics Materiel to Prevent Enemy Use.....TM 750-244-2

Procedures for Destruction of Equipment in Federal Supply Classifications 1000, 1005, 1010, 1015, 1020, 1025, 1030, 1055, 1090, and 1095 to Prevent Enemy Use.....TM 750-244-7

Procedures for Destruction of Tank-Automotive Equipment to Prevent Enemy Use (US Army Tank-Automotive Command).....TM 750-244-6

Unit and Direct Support Maintenance Repair Parts and Special Tools List for Mortar, 120-MM M121 or M120.....TM 9-1015-250-23&P

Unit and Intermediate Direct Support Maintenance Manual (Including Repair Parts and Special Tools Lists): M107MM Turntable and Mount (10885903), 81MM Mortar Turntable and Mount (10885812); 81MM Mortar-Bipod Assembly (10918100).....TM 9-1015-232-23&P

Unit Maintenance: Carrier, Personnel, Armored, M113A3 (2350-01-219-7577); Carrier, Command Post, M577A3 (2350-01-369-6085); Carrier, Smoke Generator, M1059A3 (2350-01-369-6083); Carrier, Mortar, 120-MM M121, M1064A3 (2350-01-369-6082); Carrier, Standardized Integrated Command Post System (SICPS), M1068A3 (2350-01-369-6086); Chassis, Mechanized Smoke Obscurant, M58 (2350-01-418-6654).....TM 9-2350-277-20

Unit Maintenance, Direct Support and General Support Maintenance Repair Parts and Special Tools List: Carrier, Personnel, Armored, M113A3 (2350-01-219-7577); Carrier, Command Post, M577A3 (2350-01-369-6085); Carrier, Smoke Generator, M1059A3 (2350-01-369-6083); Carrier, Mortar, 120-MM M121, M1064A3 (2350-01-369-6082); Carrier, Standardized Integrated Command Post System (SICPS), M1068A3 (2350-01-369-6086); Chassis, Mechanized Smoke Obscurant, M58 (2350-01-418-6654).....TM 9-2350-277-24P

Unit Maintenance Manual: Generator, Smoke, Mechanical: Mechanized Smoke Obscurant System, M58 (1040-01-413-8332).....TM 3-1040-285-20

REFERENCES—Continued

0119 00

Unit Maintenance Manual (Including Repair Parts and Special Tools Lists): Generator Set,
 Smoke, Mechanical: Pulse Jet M157A2.....TM 3-1040-283-20&P

Use and Care of Hand Tools and Measuring Tools.....TM 9-243

MISCELLANEOUS PUBLICATIONS

Carrier, Command Post, Light Tracked, M577 and M577A1; Processing for Storage and
 Shipment of.....MIL-C-46746E(AT)

Carriers, Personnel, Full Tracked: Armored, M113A2 and M113A3; Mortars, Self-Propelled,
 107MM, M106, M106A2, and 81MM, M125A1 and M125A2, and 120MM, M1064; and
 Smoke Generator, M1059; Processing for Storage and Shipment of.....MIL-C-45360G(AT)

Color, Marking, and Camouflage Painting of Military Vehicles, Construction Equipment, and
 Materials-Handling Equipment.....TB 43-0209

Expendable/Durable Items (Except Medical, Class V, Repair Parts, and Heraldic Items).....CTA 50-970

Safety Inspection and Testing of Lifting Devices.....TB 43-0142

The Army Maintenance Management System (TAMMS).....DA PAM 738-750

Solder and Soldering.....TB SIG 222

Welding Code.....12472301

COMMON TOOLS AND SUPPLEMENTS AND SPECIAL TOOLS/FIXTURES LIST

0120 00

INTRODUCTION

Scope

This work package lists all common tools, supplements and special tools/fixtures needed to maintain the M113A3, M577A3, M1059A3, M1064A3, M1068A3, and M58 carriers.

Explanation of Columns

Column (1) — Item Number. This number is assigned to the entry in the listing and is referenced in the Initial Setup to identify the item (e.g., “Sander, disk, electric”).

Column (2) — Name. This column lists the item by noun nomenclature and other descriptive features (e.g., “Wrench set, socket, 1/4 drive”).

Column (3) — National Stock Number. This is the National Stock Number (NSN) assigned to the item; use it to requisition the item.

Column (4) — Part Number. Indicates the primary number used by the manufacturer (individual, company, firm, corporation, or Government activity), which controls the design and characteristics of the item by means of its engineering drawings, specifications, standards, and inspection requirements to identify an item or range of items.

Column (5) — Reference. This column identifies the authorizing Supply Catalog (SC) or Repair Parts and Special Tools List (RPSTL) for items listed in this appendix.

Table 1. Tool Identification List

(1) ITEM NO.	(2) ITEM NAME	(3) NATIONAL STOCK NUMBER	(4) PART NUMBER	(5) REFERENCE
1	ADAPTER, SPINDLE, PORTABLE SANDER	5130-00-293-2330		SC 4940-95-CL-B04
2	APRON, IMPERMEABLE	8415-00-082-6108		SC 4910-95-CL-A76
3	BAR, BUCKING, RIVET	5120-00-293-2501	44B14865	TM 9-2350-277-24P
4	BIT, SCREWDRIVER, 3/16 HEX (PART OF IMPACT WRENCH SET)	5130-00-049-7913		SC 4910-95-CL-A31
5	BRUSH, WIRE, SCRATCH	7920-00-291-5815		SC 4910-95-CL-A76
6	DEGREASER	4940-00-078-9192		SC 4910-95-CL-A76
7	DRILL, ELECTRIC, PORTABLE, 1/2 INCH	5130-00-889-9004		SC 4910-95-CL-A31
8	DRILL, ELECTRIC, PORTABLE, MORSE #2	5130-00-473-6228		SC 4910-95-CL-A31
9	DRILL SET, TWIST, 1/16 TO 1/2 INCH, RND SHANK	5133-00-293-0983		SC 4910-95-CL-A31
10	DRILL SET, TWIST, 33/64 TO 3/4 INCH, MORSE #2	5133-00-596-8088		SC 4910-95-CL-A31
11	DRILL, TWIST, 1-1/32, MORSE #3	5133-00-228-1351	25154	TM 9-2350-277-24P
12	DRILL, TWIST, 57/64, MORSE #2	5133-00-277-6942	74357	TM 9-2350-277-24P
13	DRIVE TOOL, LOCKRING	5120-01-165-0448	R112D	TM 9-2350-277-24P
14	EXTRACTOR SET, SCREW	5120-00-610-1888		SC 4910-95-CL-A31

COMMON TOOLS AND SUPPLEMENTS AND SPECIAL TOOLS/FIXTURES

0120 00

LIST—Continued

(1) ITEM NO.	(2) ITEM NAME	(3) NATIONAL STOCK NUMBER	(4) PART NUMBER	(5) REFERENCE
15	FACE, HAMMER, INSERTED, MEDIUM PLASTIC	5120-00-585-8202		SC 4910-95-CL-A31
16	FLOW TEST MACHINE, RADIATOR	4910-00-075-2395		SC 4910-95-CL-A76
17	FRAME, HACKSAW	5110-00-289-9657	163-20	SC 4910-95-CL-A31
18	GLOVES, WELDER'S, LEATHER	8415-00-268-7859		SC 4910-95-CL-A31
19	GOGGLES, INDUSTRIAL	4240-00-052-3776		SC 4910-95-CL-A76
20	HAMMER, PNEUMATIC, PORTABLE	5130-00-889-8984	A-A-2350	GSA SUPPLY CATALOG
21	HELMET, WELDER'S	4240-00-540-0623		SC 3431-95-CL-A01
22	HOLDER, INSERTED HAMMER FACE	5120-00-903-8553		SC 4910-95-CL-A31
23	HOLDER KIT, THREAD INSERTER	5180-00-966-5958	10932383	TM 9-2350-277-24P
24	INDICATOR SET, DIAL	5210-00-402-9619	J7872	SC 4910-95-CL-A31
25	INSERTER, BEARING	5120-01-263-3628	CRB2112D	TM 9-2350-277-24P
26	INSERTER, BEARING	5120-00-708-2641	R108D	TM 9-2350-277-24P
27	INSERTER, BEARING	5120-00-473-7013	R206D	TM 9-2350-277-24P
28	INSERTER, BEARING	5120-00-473-7017	R210D	TM 9-2350-277-24P
29	INSERTER, BEARING	5120-00-378-4276	R212D	TM 9-2350-277-24P
30	INSERTER, BEARING	5120-01-249-6363	R213D	TM 9-2350-277-24P
31	INSERTER, SCREW THREAD	5120-01-163-1425	CR06W	TM 9-2350-277-24P
32	INSERTER, SCREW THREAD	5120-01-253-1860	CR08W	TM 9-2350-277-24P
33	INSERTER, SCREW THREAD	5120-01-163-9922	CR10W	TM 9-2350-277-24P
34	INSERTER, SCREW THREAD	5120-01-159-6487	CR12W	TM 9-2350-277-24P
35	INSERTER, SCREW THREAD	5120-01-254-1497	CR13W	TM 9-2350-277-24P
36	INSERTER, SCREW THREAD	5120-01-250-6420	CRB2112WIS	TM 9-2350-277-24P
37	LUBRICATING KIT	4930-00-357-6301	A-A-2350	SC 4910-95-CL-A31
38	MULTIMETER, DIGITAL	6625-01-139-2512		SC 4910-95-CL-A01
39	PLIERS, RETAINING RING, EXTERNAL	5120-00-595-9552		SC 4910-95-SC-A31
40	PLIERS, RETAINING RING, INTERNAL	5120-00-293-0048		SC 4910-95-CL-A31
41	PLUG SET, RADIATOR TEST	4910-00-273-3660		SC 4910-95-CL-A76
42	POSITIONER, BEARING	4910-01-128-0093	12313101	TM 9-2350-277-24P
43	PRESS, ARBOR, HAND OPERATED	3444-00-449-7295		SC 4910-95-CL-A31
44	PULLER KIT, MECHANICAL	5120-00-423-1596		SC 4910-95-CL-A62

COMMON TOOLS AND SUPPLEMENTS AND SPECIAL TOOLS/FIXTURES
LIST—Continued

0120 00

(1) ITEM NO.	(2) ITEM NAME	(3) NATIONAL STOCK NUMBER	(4) PART NUMBER	(5) REFERENCE
45	PULLER SET	5120-01-140-0950	4205A	TM 9-2350-277-24P
46	SANDER, DISK, ELECTRIC, PORTABLE	5130-00-857-8526	00S90	SC 4910-95-CL-A31
47	SANDER, DISK, ELECTRIC, PORTABLE	5130-00-596-9728		SC 3431-95-CL-A01
48	SCALE, MAIL AND PARCEL POST (5 LBS)	6670-01-021-4860	1509	SC 4910-95-CL-A31
49	SCREW, CAP, HEXAGON	5305-00-267-8954	MS90727-10	IMPROVISED TOOL
50	SCREW, CAP, SOCKET HEAD (JACKING)	5305-00-978-9380	MS16997-61	IMPROVISED TOOL
51	SEWING MACHINE, INDUSTRIAL	3530-01-182-8560	206RB1	TM 9-2350-277-24P
52	SLING, ENGINE AND TRANSMISSION	1450-01-240-2206	12350306	TM 9-2350-277-24P
53	SOCKET, TAPER SHANK, MORSE #3 TO #2	3460-00-227-7524	00-S-550	TM 9-2350-277-24P
54	SOLDERING GUN	3439-00-542-0396	8200G3	SC 4910-95-CL-A31
55	STAKER, BEARING	5120-01-128-0094	12313102	TM 9-2350-277-24P
56	STAND, RADIATOR TEST AND REPAIR	4910-00-078-9190		SC 4910-95-CL-A76
57	TAPE, MEASURING	5120-00-234-6745	GGG-T-106	SC 4910-95-CL-A31
58	THREADING SET, SCREW	5180-00-448-2362		SC 4910-95-CL-A31
59	TOOL KIT, AUTOMOTIVE FUEL AND ELECTRICAL SYSTEM REPAIR	5180-00-754-0655		SC 5180-95-CL-B08
60	TOOL KIT, ELECTRICAL CONNECTOR REPAIR	5180-00-876-9336		SC 4910-95-CL-A31
61	TOOL KIT, ELECTRONIC EQUIPMENT	5180-00-610-8177	TK-105/G	SC 5180-91-CL-R07
62	TOOL KIT, GENERAL MECHANIC'S	5180-00-177-7033		SC 5180-90-CL-N26
63	TOOL KIT, METALWORKER'S	5180-00-754-0643		SC 5180-90-CL-N34
64	TOOL KIT, OVERSIZE ROSAN INSERT	5180-00-966-5961	10932474	TM 9-2350-277-24P
65	TOOL KIT, RADIO EQUIPMENT	5180-00-064-5178	TK-101/G	SC 5180-91-CL-R13
66	TRESTLE, MOTOR VEHICLE MAINTENANCE	4910-00-251-8013	12998F	SC 4910-95-CL-A31
67	WASHER, FLAT	5310-00-809-4058	MS27183-10	IMPROVISED TOOL
68	WELDING MACHINE, ARC	3431-01-032-6289		SC 3431-95-CL-A01
69	WELDING SHOP, TRAILER MOUNTED	3431-00-935-7821		SC 3431-95-CL-A01
70	WRENCH, ADJUSTABLE	5120-00-423-6728		SC 4910-95-CL-A31
71	WRENCH, OPEN END, 1 X 1-1/8	5120-00-187-7133		SC 4910-95-CL-A31
72	WRENCH, OPEN END 1-5/16 X 1-1/2	5120-00-277-2323		SC 4910-95-CL-A31
73	WRENCH, TORQUE, 1/2 DRIVE, 0-175 LB-FT	5120-00-640-6364		SC 4910-95-CL-A31

**COMMON TOOLS AND SUPPLEMENTS AND SPECIAL TOOLS/FIXTURES
LIST—Continued**

0120 00

(1) ITEM NO.	(2) ITEM NAME	(3) NATIONAL STOCK NUMBER	(4) PART NUMBER	(5) REFERENCE
74	WRENCH, TORQUE, 1/2 DRIVE, 0-300 LB-IN	5120-00-247-2536	F3001	SC 4910-95-CL-A31
75	WRENCH, TORQUE, 1/2 DRIVE, 0-150 LB-FT	5120-00-247-2540	F150	SC 4910-95-CL-A31
76	WRENCH, TORQUE, 3/4 DRIVE, 0-600 LB-FT	5120-00-221-7983		SC 4910-95-CL-A31
77	WRENCH KIT, METRIC	5120-01-070-8954		SC 4910-95-CL-A72
78	WRENCH SET, SOCKET, 3/4 INCH DRIVE	5120-00-204-1999		SC 4910-95-CL-A31

FABRICATED TOOLS

0121 00

INTRODUCTION

SCOPE

This work package includes instructions for making tools authorized to be fabricated at DS or GS maintenance levels. These tools are needed for special maintenance procedures, but are not available in the supply system. The tools are normally fabricated locally when required by the troubleshooting or maintenance task.

FABRICATION INSTRUCTIONS

The following figures provide tool fabrication instructions. All parts and bulk materials needed for manufacturing the tool are listed on each figure. When needed, any special explanatory instructions are included in the notes on the figure.

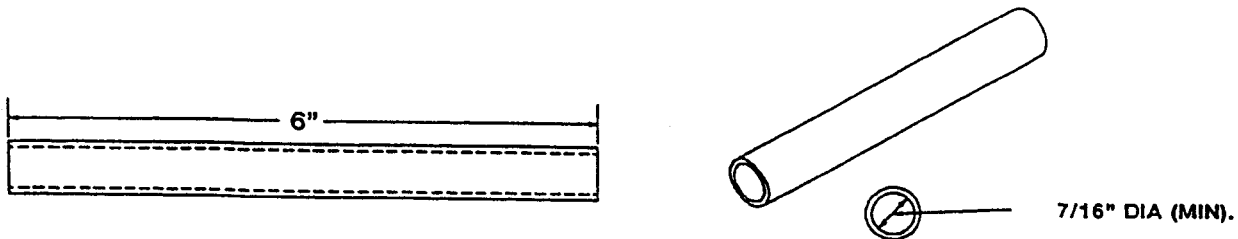
**MATERIAL REQUIRED**

Round steel stock 1020 or 1040, or locally procured steel pipe.

NOTES:

1. Remove all burrs.
2. Do not break sharp edges.
3. All dimensions are in inches.

Lock Ring Drive Tool for Stud Insert

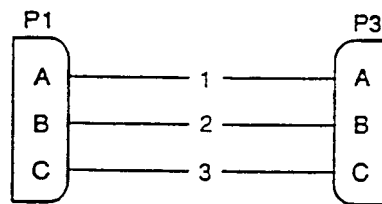
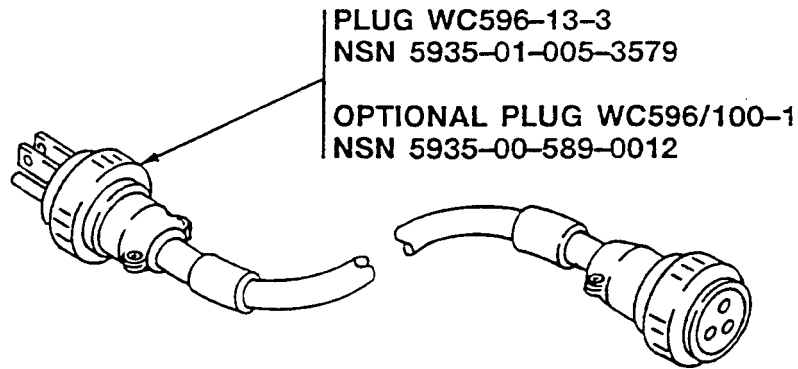

WIRING DIAGRAM

1 = HOT
2 = NEUTRAL
3 = GROUND

PARTS REQUIRED

W3 Cable P/N 12383899

Plug WC596-13-3 or WC596/100-1

NOTES

1. Remove connector labeled W3P1 (A3J1) from W3 Cable.
2. Cut cable to required length (for connecting Power Control Enclosure to AC outlet).

WARNING



Incorrect polarity can harm personnel and damage equipment when power is applied to the Power Control Enclosure. Make sure polarity is correct when installing plug on cable.

3. Install new plug WC596-13-3 or WC596/100-1 on W3 cable. Connect per wiring diagram.
4. Purpose of cable is to connect the Power Control Enclosure to shop AC power.

Special Purpose Power Cable for Power Control Enclosure (M1068A3 Only)

EXPENDABLE/DURABLE SUPPLIES AND MATERIALS LIST

0122 00

INTRODUCTION

Scope

This appendix lists expendable and durable items you will need to maintain the M113A3, M577A3, M1059A3, M1064A3, M1068A3, and M58 Carriers. These items are authorized to you by CTA 50-970, *Expendable/Durable Items (Except Medical, Class V, Repair Parts, and Heraldic Items)*.

Explanation of Columns in the Expendable/Durable Items List

Column (1) — Item Number. This number is assigned to the entry in the listing, and is referenced in the Materials/Parts section of the task to identify the item (e.g., “Automotive grease (Item 6)).

Column (2) — Level. This column identifies the lowest level of maintenance that requires the listed item.
 O — Unit Maintenance
 F — Direct Support Maintenance
 H — General Support Maintenance

Column (3) — National Stock Number. This is the National Stock Number (NSN) assigned to the item. Use it to requisition the item.

Column (4) — Description. Indicates the Federal item name and, if required, a description to identify the item. The description is followed by the Commercial and Government Entity Code (CAGEC) and part number for each item.

Column (5) — Unit of Measure (U/M). Indicates the measure used in performing the actual maintenance function. This measure is expressed by a two-character alphabetical abbreviation (e.g., EA, IN, PR). If the unit of measure differs from the unit of issue, requisition the lowest unit of issue that will satisfy the requirements.

Table 1. Expendable and Durable Items List

(1) ITEM NUMBER	(2) LEVEL	(3) NATIONAL STOCK NUMBER	(4) ITEM NAME,DESCRIPTION,CAGE,PART NUMBER	(5) U/M
1	O	8040-00-664-4318	ADHESIVE (04963) EC2141	PT
2	O	8040-01-068-2423	ADHESIVE (94960) 2141PT	PT
3	O	8040-00-839-4919	ADHESIVE SEALANT (04963) EC-1099	PT
4	O	6850-00-181-7940	ANTIFREEZE (81349) MIL-A-46153	GL
5	F	8030-00-597-5367	ANTISEIZE COMPOUND (81349) MIL-A-907	CN
6	O	9150-01-197-7692	AUTOMOTIVE GREASE (81349) MIL-G-10924	LB
7	F	8030-00-664-4944	CANVAS PRESERVATIVE (81348) TT-P-595	GL
8	O	6850-01-277-0595	CLEANING COMPOUND (59557) 134-HI-SOLV	GL

EXPENDABLE/DURABLE SUPPLIES AND MATERIALS LIST—Continued

0122 00

(1) ITEM NUMBER	(2) LEVEL	(3) NATIONAL STOCK NUMBER	(4) ITEM NAME,DESCRIPTION,CAGE,PART NUMBER	(5) U/M
9	O	6850-01-244-3207	CLEANING COMPOUND (59557) 134-HI-SOLV	DR
10	F	8305-00-170-3903	COTTON DUCK CLOTH (81348) CCCC428	YD
11	F	5350-00-221-0872	CROCUS CLOTH (81348) PC458T1C1	EA
12	F	8010-01-123-3347	ENAMEL (81349) MIL-C-46168	QT
13	O	9150-01-152-4119	ENGINE LUBRICATING OIL (81349) MILL2104GRADE15W40	GL
14	O	7930-00-282-9699	GENERAL DETERGENT (77092) TRITONX-100	GL
15	O	5110-00-277-4588	HACKSAW BLADE (54940) 31-51024	EA
16	O	9150-01-131-3323	HYDRAULIC FLUID (81349) MIL-H-46170	QT
17	F	6850-00-269-1878	INSPECTION PENETRANT (81348) MIL-I-25135 TYII	
18	O	5970-00-161-7422	INSULATING VARNISH (24446) 1201	EA
19	O	5970-00-816-6056	INSULATION TAPE (81348) HH-I-595-B-108-0	FT
20	O	9150-00-754-2595	MOLYBDENUM D GREASE (81349) MIL-G-21164	LB
21	F	9330-01-141-4504	PLASTIC MOLDING MATERIAL (81349) MIL-P-21929	EA
22	F	8310-00-988-1301	POLYESTER THREAD (70167) 23B28030-3	EA
23	O	8040-01-383-7059	PRIMER, ADHESIVE (05972) LOCTITE 7649	PT
24	O	8010-00-292-1127	PRIMER COATING (LEAD & CHROMATE FREE) (81348) TT-P-664	GL
25	F	8030-00-174-2598	SEALING COMPOUND (03956) P1896694-3	PT
26	O	8030-00-058-5398	SEALING COMPOUND (81349) MIL-S-22473	PT
27	O	8030-01-166-0675	SEALING COMPOUND (05972) 567-47	EA

EXPENDABLE/DURABLE SUPPLIES AND MATERIALS LIST—Continued

0122 00

(1) ITEM NUMBER	(2) LEVEL	(3) NATIONAL STOCK NUMBER	(4) ITEM NAME,DESCRIPTION,CAGE,PART NUMBER	(5) U/M
28	F	8030-00-723-5344	SEALING COMPOUND (FUEL) (83574) PR1440A-2	PT
29	O	6850-00-880-7616	SILICONE COMPOUND (81349) MIL-S-8660	OZ
30	O	8040-00-728-3088	SILICONE SEALANT ADHESIVE (78500) 1199-T-3842	OZ
31	O	3940-00-675-5003	SLING (ENDLESS) (81996) PD101-96	EA
32	F	3439-01-219-7884	SOLDERING FLUX (85150) DAYFLO STD	OZ
33	O	3439-00-453-5472	TIN ALLOY SOLDER (81348) SN60WRMAP2 0.0361LB	LB
34	O	8305-00-616-0022	VINYL COATED NYLON CLOTH (81349) MIL-C-20696	YD
35	F	3439-00-803-9498	WELDING ELECTRODE (31505) AWSA5,10-80 ER5356	OZ
36	O	7920-00-205-1711	WIPING RAG (58536) A-A-2522	LB

INDEX

<u>Subject</u>	<u>WP Sequence No.-Page No.</u>
A	
AC Power Extension Box A6 (M1068A3) Repair.....	0097 00-1
AC Power Extension Box A7 (M1068A3) Repair.....	0097 00-1
Accelerator Stop Support Assembly Repair.....	0018 00-1
Anchor Kit (M1059A3) Install	0087 00-1
Ramp Hydraulic Cylinder (M1064A3) Replacement.....	0065 00-1
Auxiliary Power Unit Cover (M577A3 and M1068A3) Repair	0071 00-1
B	
Battery Repair.....	0025 00-1
Bearing Commander's Cupola (M113A3, M1059A3, M1064A3, and M58) Repair	0052 00-1
Housing and Drive Shaft, Fan Repair	0022 00-1
Bearings Ramp Access Door Hinge (M113A3) Replace	0058 00-1
Shaft Housing Repair	0038 00-1
Steering Bracket Repair	0038 00-1
Blower motor Engine coolant heater Replace	0084 00-1

INDEX - Continued

Subject WP Sequence No.-Page No.

B - Continued

Box	
STE/ICE Distribution Box	
Repair	0109 00-1
Bracket	
Warning Light Panel, Mounting	
Replace	0024 00-1
Burner Packing and Gasket	
Replace	0082 00-1

C

Capstan Kit	
(M1059A3)	
Install	0086 00-1
Cargo Hatch Hinge	
(M113A3 and M1059A3)	
Repair	0048 00-1
Chemical Fire Extinguisher	
(M1059A3 Only)	
Service	0111 00-1
Closure And Frame	
Shipping (All Except M577A3 and M1068A3)	
Remove	0113 00-1
Commander's Cupola	
Bearing (M113A3, M1059A3, M1064A3, and M58)	
Repair	0052 00-1
(M113A3, M1059A3, M1064A3, and M58)	
Repair	0051 00-1
Replace (M113A3, M1059A3, M1064A3, and M58)	0050 00-1
Commander's Cupola Armor Shields	
M113A3 and M1064A3 only	
Install	0088 00-1
Commander's Cupola Cover Hinges	
(M113A3, M1059A3, M1064A3, and M58)	
Repair	0053 00-1
Commander's Cupola Hinges	
(M113A3, M1059A3, M1064A3, and M58)	
Repair	0054 00-1

INDEX - Continued

Subject WP Sequence No.-Page No.

C - Continued

Commander's Hatch Cover Hinges (M577A3 and M1068A3) Repair	0055 00-1
Commander's Hatch Cover Hull Hinges (M577A3 and M1068A3) Repair	0056 00-1
Connectors, Multipin Repair	0026 00-1
Cover Auxiliary Power Unit (M577A3 and M1064A3) Repair	0071 00-1
Cover hinges Driver's hatch Repair	0060 00-1
Curbside AC Power Extension Box A19 (M1068A3), Repair	0104 00-1
Curbside Data Panel Assembly A13 (M1068A3), Repair	0101 00-1

D

Diode Engine Coolant Heater Replace	0083 00-1
Door Ramp Access Replace	0057 00-1
Ramp Access (All Except M113A3) Repair	0059 00-1
Drive Shaft and Bearing Housing, Fan Repair	0022 00-1
Variable Speed Fan and Generator (Old Configuration) Repair	0115 00-1
Driver's hatch cover hinges Repair	0060 00-1

INDEX - Continued

Subject

WP Sequence No.-Page No.

D – Continued

Driver's Hatch Cover Hull Hinges
 Repair 0061 00-1

E

Engine

Coolant Heater
 Data 0076 00-1
 Replacement 0015 00-1

Stand
 Adjust 0068 00-1
 Repair 0070 00-1
 Service 0069 00-1

Wiring Harness
 Repair 0027 00-1

Engine Coolant Heater

Diode
 Replace 0083 00-1

Motor Resistor
 Replace 0083 00-1

Engine Coolant Heater Data 0076 00-1

Engine Coolant Heater Kit
 (M113A3 and M1059A3)

Install 0075 00-1

Equipment Description

Location and Description of Major Components 0002 00-1

Extension Box

Roadside AC Power A18
 (M1068A3), Repair 0103 00-1

Roadside DC Power
 Repair 0098 00-1

Extension Box A19

Curbside AC Power
 (M1068A3), Repair 0104 00-1

Extension Box A6

AC Power
 (M1068A3) Repair 0097 00-1

INDEX - Continued

Subject

WP Sequence No.-Page No.

E – Continued

Extension Box A7
 AC Power
 (M1068A3) Repair 0097 00-1

External Communication Box A11
 (M1068A3)
 Repair 0100 00-1

F

Fan
 Assembly, Ventilating
 Repair 0021 00-1
 Drive Shaft and Bearing Housing
 Repair 0022 00-1

Fan and Generator
 Variable Speed Drive (Old Configuration)
 Repair 0115 00-1

Final Drive Assembly
 Repair/Overhaul 0116 00-1

Final Test
 Coolant Heater 0077 00-1

Fire Extinguisher
 Chemical (M1059A3 Only)
 Service 0111 00-1
 Cylinder and Safety Disc
 Service 0112 00-1

Fixed Resistor
 Replace 0081 00-1

Frame
 Shipping Closure (M577A3 and M1068A3 Only)
 Remove 0114 00-1

Front main wiring harness
 Replacement 0030 00-1

Fuel control valve
 Replace 0078 00-1

INDEX - Continued

Subject WP Sequence No.-Page No.

F – Continued

Fuel Tank
 Repair 0017 00-1

G

General Information 0001 00-1

General Maintenance Instructions 0014 00-1

Generator
 Repair 0023 00-1
 Variable Speed Drive (Old Configuration)
 Repair 0115 00-1

H

Heater
 Coolant
 Final Test 0077 00-1

Hinge
 Cargo Hatch (M113A3 and M1059A3)
 Repair 0048 00-1
 Hopper Hatch (M58)
 Repair 0049 00-1
 Power Plant Door
 Repair 0047 00-1

Hinge, Cargo Hatch
 (M113A3 and M1059A3)
 Installation 0048 00-1
 Removal 0048 00-1

Hinges
 Commander's Cupola
 (M113A3, M1059A3, M1064A3, and M58)
 Repair 0054 00-1
 Commander's Cupola Cover
 (M113A3, M1059A3, M1064A3, and M58)
 Repair 0053 00-1
 Commander's Hatch Cover
 (M577A3 and M1068A3)
 Repair 0055 00-1
 Hull
 Commander's Hatch Cover (M577A3 and M1068A3)
 Repair0056 00-1

INDEX - Continued

Subject WP Sequence No.-Page No.

H – Continued

Driver's Hatch Cover	
Repair	0061 00-1
Ramp Access Door	
Replace	0057 00-1
Hopper Hatch Hinge	
(M58)	
Repair	0049 00-1

I

Idler Arm	
Track	
Repair	0036 00-1
Inserts	
Screw	
Serrated Lock Ring	
Replace	0040 00-1
Inserts and Packing	
Screw	
Serrated Lock Ring	
Replace	0041 00-1
Inserts, Screw	
Key Locked	
Replace	0042 00-1
Oversize Lockring	
Replace	0118 00-1
Inverter	
(M1068A3)	
Repair	0094 00-1
Replacement	0094 00-1
Inverter Housing Assembly A2	
(M1068A3)	
Repair	0094 00-1
Replacement	0094 00-1

K

Key Locked Screw Inserts	
Replace	0042 00-1
Kit	
Anchor	
(M1059A3)	
Install	0087 00-1

INDEX - Continued

Subject WP Sequence No.-Page No.

K – Continued

Non-Skid Ramp
(M1064A3)
Install 0085 00-1

Personnel heater
(M1064A3)
Installation0073 00-1
(M113A3, M1059A3, and M58 only)
Installation 0072 00-1

Kit, Engine Coolant Heater
(M113A3 and M1059A3)
Install 0075 00-1

L

LAN A Cable W101 and/or LAN B Cable W102 (M1068A3)
Replace 0105 00-1

Locked-In Studs
(M577A3)
Replacement 0117 00-1

Lockring Screw Inserts
Oversize
Replace 0118 00-1

M

Multipin Connectors
Repair 0026 00-1

N

Nomenclature Cross-Reference List 0001 00-3

Non-Skid Ramp Kit
(M1064A3)
Install 0085 00-1

O

Overheat Thermostat
Replace 0080 00-1

Oversize Screw Inserts With Lockring
Replace 0118 00-1

P

Packing and Gasket
Burner
Replace 0082 00-1

INDEX - Continued

<u>Subject</u>	<u>WP Sequence No.-Page No.</u>
P – Continued	
Panel Assembly A12	
Roadside Data	
(M1068A3), Repair	0101 00-1
Panel Assembly A13	
Curbside Data	
(M1068A3), Repair	0101 00-1
Panel box assembly A5	
Tent interface	
(M1068A3 only)	
Repair	0096 00-1
Personnel Heater Assembly	
Repair	0074 00-1
Personnel heater kit	
(M1064A3)	
Installation	0073 00-1
(M113A3, M1059A3, and M58 only)	
Installation	0072 00-1
Phone Extension Box A14	
(M1068A3),Repair	0102 00-1
Power Control Enclosure	
Rear Panel	
(M1068A3)	
Repair	0093 00-1
Right Panel	
(M1068A3)	
Repair	0092 00-1
Power Control Enclosure Left Panel	
(M1068A3)	
Repair	0091 00-1
Power Control Enclosure Power Supplies	
(M1068A3)	
Replace	0090 00-1
Power entry box assembly	
(M1068A3 only)	
Repair	0095 00-1

INDEX - Continued

Subject WP Sequence No.-Page No.

P – Continued

Power Plant	
Sling	
Repair	0067 00-1
Test Load	0066 00-1
 Power Plant Door Hinge	
Repair	0047 00-1
 Power Supplies	
Power Control Enclosure (M1068A3)	
Replace	0090 00-1
 Pressnut	
Replace	0043 00-1
 Preventive Maintenance Checks and Services (PMCS), Including Lubrication Instructions	0014 00-1

R

Radiator	
Auxiliary Tank	
Repair	0020 00-1
Repair	0019 00-1
 Ramp	
Hydraulic Cylinder Anchor (M1064A3)	
Replacement	0065 00-1
 Ramp Access Door (All Except M113A3)	
Repair	0059 00-1
 Ramp Access Door Hinge Bearings (M113A3)	
Replace	0058 00-1
 Ramp Kit	
Non-Skid (M1064A3)	
Install	0085 00-1
 References	0119 00-1

INDEX - Continued

Subject WP Sequence No.-Page No.

R – Continued

Resistor	
Engine Coolant Heater Motor	
Replace	0083 00-1
Fixed	
Replace	0081 00-1
Restriction Thermostat	
Replace	0079 00-1
Roadside AC Power Extension Box A18	
(M1068A3), Repair	0103 00-1
Roadside Data Panel Assembly A12	
(M1068A3), Repair	0101 00-1
Roadside DC Power Extension Box A9	
Repair	0098 00-1

S

Safety Disc	
Fire Extinguisher Cylinder	
Service	0112 00-1
Screw Inserts	
Key Locked	
Replace	0042 00-1
Serrated Lock Ring	
Replace	0040 00-1
Screw Inserts and Packing	
Serrated Lock Ring	
Replace	0041 00-1
Screw Inserts, Oversize	
With Lockring	
Replace	0118 00-1
Shaft Housing Bearings	
Repair	0038 00-1
Shields	
Commander's cupola armor	
(M113A3 and M1064A3 Only)	
Install	0088 00-1
Shipping Closure and Frame	
(M577A3 and M1068A3 Only)	
Remove	0114 00-1

INDEX - Continued

<u>Subject</u>	<u>WP Sequence No.-Page No.</u>
S – Continued	
Shipping Closure And Frame (All Except M577A3 and M1068A3)	
Remove	0113 00-1
Shock Absorber	
Repair	0039 00-1
Signal Patch Panel Box A10	
Repair	0099 00-1
Sling, Power Plant	
Repair	0067 00-1
Test Load	0066 00-1
Smoke Grenade Launcher Wiring Harness	
Repair (M113A3 and M1059A3)	0033 00-1
Splash Guard	
Left or Right	
Replace	0044 00-1
Stand	
Engine and Transmission	
Adjust	0068 00-1
STE/ICE	
Distribution Box	
Repair	0109 00-1
STE/ICE Wiring Harness	
Repair	0110 00-1
Steering	
Lock Switch Wiring Harness	
Repair	0034 00-1
Steering Bracket Bearings	
Repair	0038 00-1
Studs	
Locked-In (M577A3)	
Replacement	0117 00-1
Support Assembly	
Accelerator Stop	
Repair	0018 00-1

INDEX - Continued

<u>Subject</u>	<u>WP Sequence No.-Page No.</u>
T	
Tank	
Fuel	
Repair	0017 00-1
Radiator Auxiliary	
Repair	0020 00-1
Tent	
(M1068A3)	
Repair	0063 00-1
(M577A3)	
Repair	0062 00-1
Tent interface panel box assembly A5	
(M1068A3 only)	
Repair	0096 00-1
Thermostat	
Overheat	
Replace	0080 00-1
Restriction	
Replace	0079 00-1
Track Idler Arm	
Repair	0036 00-1
Track tension adjuster	
Repair	0037 00-1
Transmission	
Control Wiring Harness	
Repair	0029 00-1
Replace	0035 00-1
Stand	
Adjust	0068 00-1
Repair	0070 00-1
Service	0069 00-1
Wiring Harness	
Repair	0028 00-1
Troubleshooting	
How to Use	0005 00-1
V	
Valve	
Fuel control	
Replace	0078 00-1

INDEX - Continued

Subject WP Sequence No.-Page No.

V - Continued

Variable Speed Drive	
Assembly Adapter	
Replace	0016 00-1
Fan and Generator	
Repair	0115 00-1
 Variable Speed Drive Assembly Adapter	
Replace	0016 00-1
 Ventilating Fan Assembly	
Repair	0021 00-1

W

Warning Light Panel Mounting Bracket	
Replace	0024 00-1
 Wiring harness	
Front main	
Replacement	0030 00-1
 Wiring Harness	
Engine	
Repair	0027 00-1
Front Main	
Repair	0031 00-1
LAN A Cable W101 and/or LAN B Cable W102 (M1068A3)	
Replace	0105 00-1
Smoke Grenade Launcher	
Repair (M113A3 and M1059A3)	0033 00-1
STE/ICE	
Repair	0110 00-1
Steering Lock Switch	
Repair	0034 00-1
Transmission	
Repair	0028 00-1
Transmission Control	
Repair	0029 00-1
 Wiring Harnesses	
Cables	
W115 (M1068A3)	
Replace	0107 00-1
W117 and W118 (M1068A3)	
Replace	0108 00-1
RF 1, 2, 3, 4 Cables W111, W112, W113, W114 (M1068A3)	
Replace	0106 00-1

INDEX - Continued

Subject

WP Sequence No.-Page No.

W – Continued

Wiring Harnesses

Cables

W115 (M1068A3)

Replace 0107 00-1

W117 and W118 (M1068A3)

Replace 0108 00-1

RF 1, 2 ,3, 4 Cables W111, W112, W113, W114 (M1068A3)

Replace 0106 00-1

RECOMMENDED CHANGES TO PUBLICATIONS AND BLANK FORMS	Use Part II (<i>reverse</i>) for Repair Parts and Special Tools Lists (RPSTL) and Supply Catalogs/Supply Manuals (SC/SM).	Date 23 JUL 01
For use of this form, see AR 25-30; the proponent agency is ODISC4.		
TO: (<i>Forward to proponent of publication or form</i>) (<i>Include ZIP Code</i>)		FROM: (<i>Activity and location</i>) (<i>include ZIP code</i>) COMMANDER COMPANY A, 216 CAV FORT KNOX, KY 40121

PART I - ALL PUBLICATIONS (EXCEPT RPSTL AND SC/SM) AND BLANK FORMS

PUBLICATION/FORM NUMBER TM 9-2350-277-34	DATE 02 JAN 01	TITLE Direct Support and General Support Maintenance Manual For M113A3 FOV
---	-------------------	---

ITEM	PAGE	PARA	LINE	FIGURE NO.	TABLE	RECOMMENDED CHANGES AND REASON
	0014 00-2					STEP b. THE SCREWS (4) ON BRACKET (2) MUST BE TORQUED PLEASE ADD TORQUE INFORMATION.
	0023 00-34			5 (SH15)		THERE ARE FOUR CLAMPS (144) ON WIRING HARNESS (217), NOT THREE AS SHOWN. PLEASE CORRECT

*Reference to line numbers within the paragraph or subparagraph.

TYPED NAME, GRADE OR TITLE	TELEPHONE EXCHANGE/AUTOVON, PLUS EXTENSION	SIGNATURE

TO: <i>(Forward direct to addressee listed in publication)</i>	FROM: <i>(Activity and location) (Include Zip Code)</i>	DATE
--	---	------

PART II - REPAIR PARTS AND SPECIAL TOOL LISTS AND SUPPLY CATALOGS/SUPPLY MANUALS

PUBLICATION NUMBER			DATE			TITLE		
PAGE NO.	COLM NO.	LINE NO.	NATIONAL STOCK NUMBER	REFERENCE NO.	FIGURE NO.	ITEM NO.	TOTAL NO. OF MAJOR ITEMS SUPPORTED	RECOMMENDED ACTION

PART III - REMARKS *(Any general remarks or recommendations, or suggestions for improvement of publications and blank forms. Additional blank sheets may be used if more space is needed.)*

SAMPLE

TYPED NAME, GRADE OR TITLE	TELEPHONE EXCHANGE/AUTOVON, PLUS EXTENSION	SIGNATURE
----------------------------	--	-----------

RECOMMENDED CHANGES TO PUBLICATIONS AND BLANK FORMS

For use of this form, see AR 25-30: the proponent agency is ODISC4.

Use Part II (*reverse*) for Repair Parts and Special Tools Lists (RPSTL) and Supply Catalogs/Supply Manuals (SC/SM).

Date

TO: (*Forward to proponent of publication or form*) (*Include ZIP Code*)

FROM: (*Activity and location*) (*include ZIP code*)

PART I – ALL PUBLICATIONS (EXCEPT RPSTL AND SC/SM) AND BLANK FORMS

PUBLICATION/FORM NUMBER
TM 9-2350-277-34

DATE
02 JAN 01

TITLE
Direct Support and General Support Maintenance Manual For M113A3 FOV

ITEM	PAGE	PARA	LINE	FIGURE NO.	TABLE	RECOMMENDED CHANGES AND REASON

**Reference to line numbers within the paragraph or subparagraph.*

TYPED, GRADE OR TITLE

TELEPHONE EXCHANGE/AUTOVON, PLUS EXTENSION

SIGNATURE

TO: <i>(Forward direct to addressee listed in publication)</i>	FROM: <i>(Activity and location) (Include Zip Code)</i>	DATE
--	---	------

PART II - REPAIR PARTS AND SPECIAL TOOL LISTS AND SUPPLY CATALOGS/SUPPLY MANUALS

PUBLICATION NUMBER			DATE			TITLE		
PAGE NO.	COLM NO.	LINE NO.	NATIONAL STOCK NUMBER	REFERENCE NO.	FIGURE NO.	ITEM NO.	TOTAL NO. OF MAJOR ITEMS SUPPORTED	RECOMMENDED ACTION

PART III - REMARKS *(Any general remarks or recommendations, or suggestions for improvement of publications and blank forms. Additional blank sheets may be used if more space is needed.)*

--

TYPED NAME, GRADE OR TITLE	TELEPHONE EXCHANGE/AUTOVON, PLUS EXTENSION	SIGNATURE
----------------------------	--	-----------

RECOMMENDED CHANGES TO PUBLICATIONS AND BLANK FORMS

For use of this form, see AR 25-30: the proponent agency is ODISC4.

Use Part II (*reverse*) for Repair Parts and Special Tools Lists (RPSTL) and Supply Catalogs/Supply Manuals (SC/SM).

Date

TO: (*Forward to proponent of publication or form*) (*Include ZIP Code*)

FROM: (*Activity and location*) (*include ZIP code*)

PART I – ALL PUBLICATIONS (EXCEPT RPSTL AND SC/SM) AND BLANK FORMS

PUBLICATION/FORM NUMBER
TM 9-2350-277-34

DATE
02 JAN 01

TITLE
Direct Support and General Support Maintenance Manual For M113A3 FOV

ITEM	PAGE	PARA	LINE	FIGURE NO.	TABLE	RECOMMENDED CHANGES AND REASON

**Reference to line numbers within the paragraph or subparagraph.*

TYPED, GRADE OR TITLE

TELEPHONE EXCHANGE/AUTOVON, PLUS EXTENSION

SIGNATURE

TO: <i>(Forward direct to addressee listed in publication)</i>	FROM: <i>(Activity and location) (Include Zip Code)</i>	DATE
--	---	------

PART II - REPAIR PARTS AND SPECIAL TOOL LISTS AND SUPPLY CATALOGS/SUPPLY MANUALS

PUBLICATION NUMBER			DATE			TITLE		
PAGE NO.	COLM NO.	LINE NO.	NATIONAL STOCK NUMBER	REFERENCE NO.	FIGURE NO.	ITEM NO.	TOTAL NO. OF MAJOR ITEMS SUPPORTED	RECOMMENDED ACTION

PART III - REMARKS *(Any general remarks or recommendations, or suggestions for improvement of publications and blank forms. Additional blank sheets may be used if more space is needed.)*

TYPED NAME, GRADE OR TITLE	TELEPHONE EXCHANGE/AUTOVON, PLUS EXTENSION	SIGNATURE
----------------------------	--	-----------

RECOMMENDED CHANGES TO PUBLICATIONS AND BLANK FORMS

For use of this form, see AR 25-30: the proponent agency is ODISC4.

Use Part II (*reverse*) for Repair Parts and Special Tools Lists (RPSTL) and Supply Catalogs/Supply Manuals (SC/SM).

Date

TO: (*Forward to proponent of publication or form*) (*Include ZIP Code*)

FROM: (*Activity and location*) (*include ZIP code*)

PART I – ALL PUBLICATIONS (EXCEPT RPSTL AND SC/SM) AND BLANK FORMS

PUBLICATION/FORM NUMBER
TM 9-2350-277-34

DATE
02 JAN 01

TITLE
Direct Support and General Support Maintenance Manual For M113A3 FOV

ITEM	PAGE	PARA	LINE	FIGURE NO.	TABLE	RECOMMENDED CHANGES AND REASON

**Reference to line numbers within the paragraph or subparagraph.*

TYPED, GRADE OR TITLE

TELEPHONE EXCHANGE/AUTOVON, PLUS EXTENSION

SIGNATURE

TO: <i>(Forward direct to addressee listed in publication)</i>	FROM: <i>(Activity and location) (Include Zip Code)</i>	DATE
--	---	------

PART II - REPAIR PARTS AND SPECIAL TOOL LISTS AND SUPPLY CATALOGS/SUPPLY MANUALS

PUBLICATION NUMBER			DATE			TITLE		
PAGE NO.	COLM NO.	LINE NO.	NATIONAL STOCK NUMBER	REFERENCE NO.	FIGURE NO.	ITEM NO.	TOTAL NO. OF MAJOR ITEMS SUPPORTED	RECOMMENDED ACTION

PART III - REMARKS *(Any general remarks or recommendations, or suggestions for improvement of publications and blank forms. Additional blank sheets may be used if more space is needed.)*

TYPED NAME, GRADE OR TITLE	TELEPHONE EXCHANGE/AUTOVON, PLUS EXTENSION	SIGNATURE
----------------------------	--	-----------

By Order of the Secretary of the Army:

Official:



JOEL B. HUDSON

*Administrative Assistant to the
Secretary of the Army*

9913204

ERIC K. SHINSEKI
*General, United States Army
Chief of Staff*

DISTRIBUTION: To be distributed in accordance with the initial distribution requirements for IDN: 371206, requirements for TM 9-2350-277-34.

THE METRIC SYSTEM AND EQUIVALENTS

LINEAR MEASURE

1 Centimeter = 10 Millimeters = 0.01 Meters = 0.3937 Inches
 1 Meter = 100 Centimeters = 1000 Millimeters = 39.37 Inches
 1 Kilometer = 1000 Meters = 0.621 Miles

WEIGHTS

1 Gram = 0.001 Kilograms = 1000 Milligrams = 0.035 Ounces
 1 Kilogram = 1000 Grams = 2.2 Lb.
 1 Metric Ton = 1000 Kilograms = 1 Megagram = 1.1 Short Tons

LIQUID MEASURE

1 Milliliter = 0.001 Liters = 0.0338 Fluid Ounces
 1 Liter = 1000 Milliliters = 33.82 Fluid Ounces

SQUARE MEASURE

1 Sq. Centimeter = 100 Sq. Millimeters = 0.155 Sq. Inches
 1 Sq. Meter = 10,000 Sq. Centimeters = 10.76 Sq. Feet
 1 Sq. Kilometer = 1,000 Sq. Meters = 0.386 Sq. Miles

CUBIC MEASURE

1 Cu. Centimeter = 1000 Cu. Millimeters = 0.06 Cu. Inches
 1 Cu. Meter = 1,000,000 Cu. Centimeters = 35.31 Cu. Feet

TEMPERATURE

$5/9 (^{\circ}\text{F} - 32) = ^{\circ}\text{C}$
 212° Fahrenheit is equivalent to 100° Celsius
 90° Fahrenheit is equivalent to 32.2° Celsius
 32° Fahrenheit is equivalent to 0° Celsius
 $(9/5 \times ^{\circ}\text{C}) + 32 = ^{\circ}\text{F}$

TO CHANGE	TO	MULTIPLY BY
Inches	Centimeters	2.540
Feet	Meters	0.305
Yards	Meters	0.914
Miles	Kilometers	1.609
Square Inches	Square Centimeters	6.451
Square Feet	Square Meters	0.093
Square Yards	Square Meters	0.836
Square Miles	Square Kilometers	2.590
Acres	Square Hectometers	0.405
Cubic Feet	Cubic Meters	0.028
Cubic Yards	Cubic Meters	0.765
Fluid Ounces	Millimeters	29.573
Pints	Liters	0.473
Quarts	Liters	0.946
Gallons	Liters	3.785
Ounces	Grams	28.349
Pounds	Kilograms	0.454
Short Tons	Metric Tons	0.907
Pound-Feet	Newton-Meters	1.356
Pounds per Square Inch	Kilopascals	6.895
Miles per Gallon	Kilometers per Liter	0.425
Miles per Hour	Kilometers per Hour	1.609

TO CHANGE	TO	MULTIPLY BY
Centimeters	Inches	0.394
Meters	Feet	3.280
Meters	Yards	1.094
Kilometers	Miles	0.621
Square Centimeters	Square Inches	0.155
Square Meters	Square Feet	10.764
Square Meters	Square Yards	1.196
Square Kilometers	Square Miles	0.386
Square Hectometers	Acres	2.471
Cubic Meters	Cubic Feet	35.315
Cubic Meters	Cubic Yards	1.308
Milliliters	Fluid Ounces	0.034
Liters	Pints	2.113
Liters	Quarts	1.057
Liters	Gallons	0.264
Grams	Ounces	0.035
Kilograms	Pounds	2.205
Metric Tons	Short Tons	1.102
Newton-Meters	Pound-Feet	0.738
Kilopascals	Pounds per Square Inch	0.145
Kilometers per Liter	Miles per Gallon	2.354
Kilometers per Hour	Miles per Hour	0.621

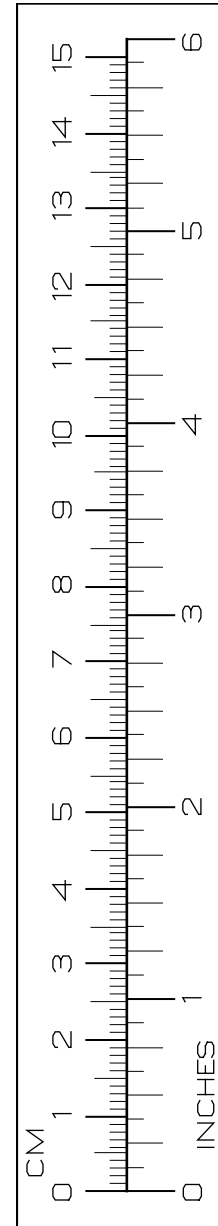

PIN: 062224-000